

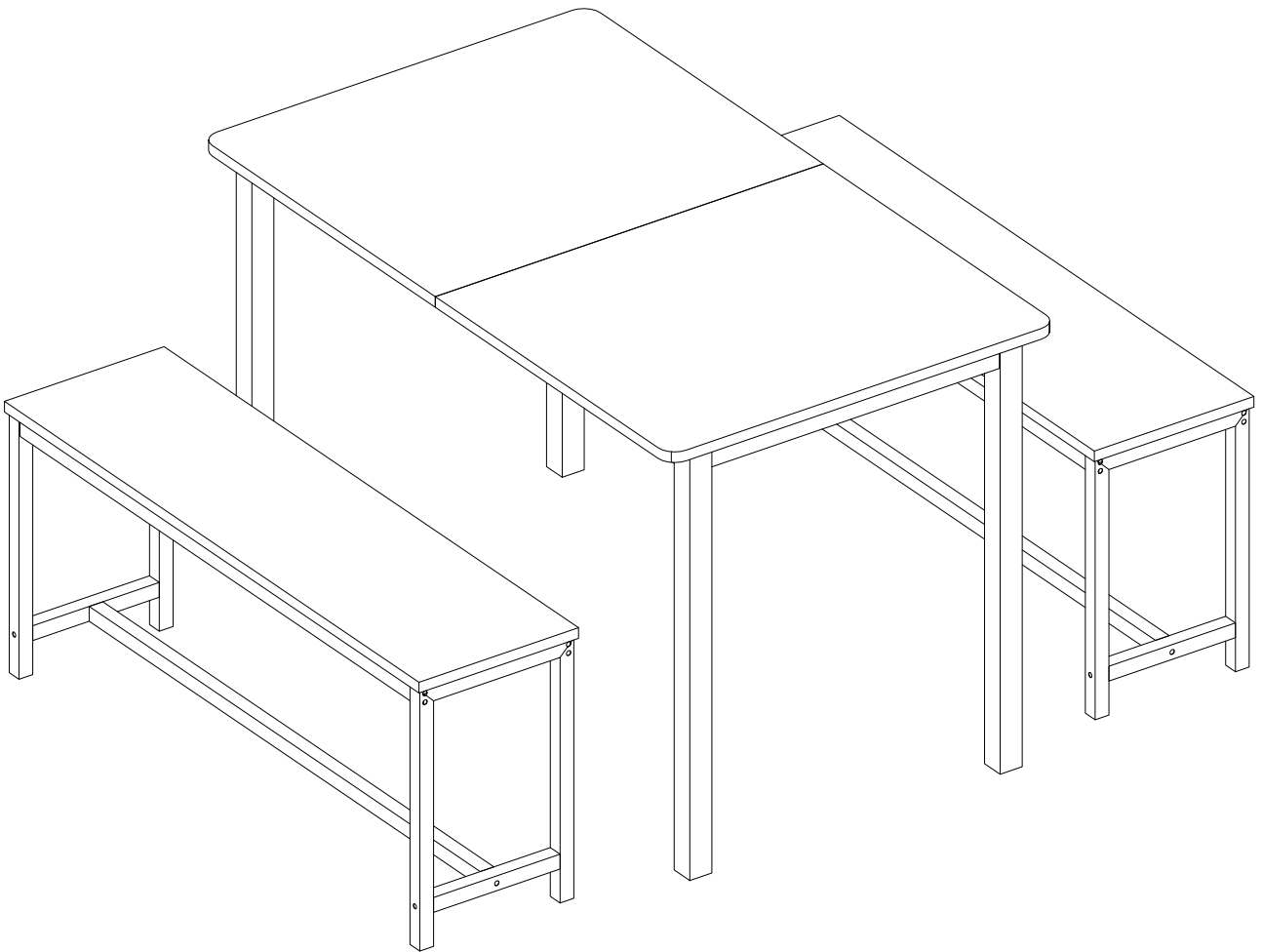







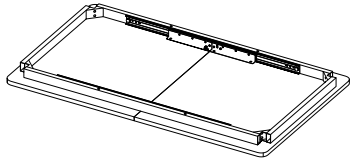
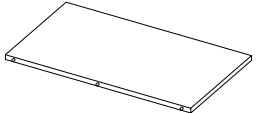
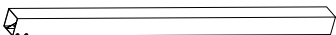

# INSTRUCTION MANUAL

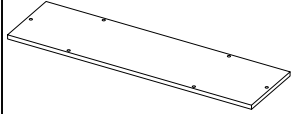
## Dining Table

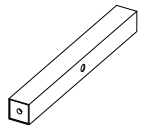

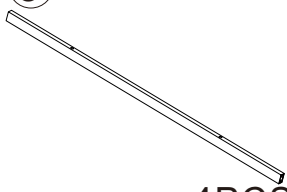
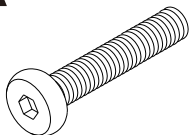
Warm Reminder: please take out all the parts/hardware and carefully examine if all the components are intact.

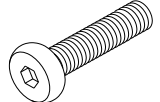
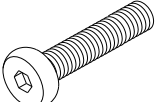
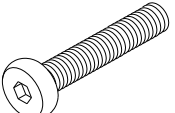
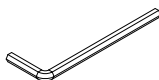
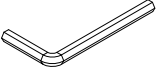

if you have a power drill, it will make the assembly process much easier and quicker

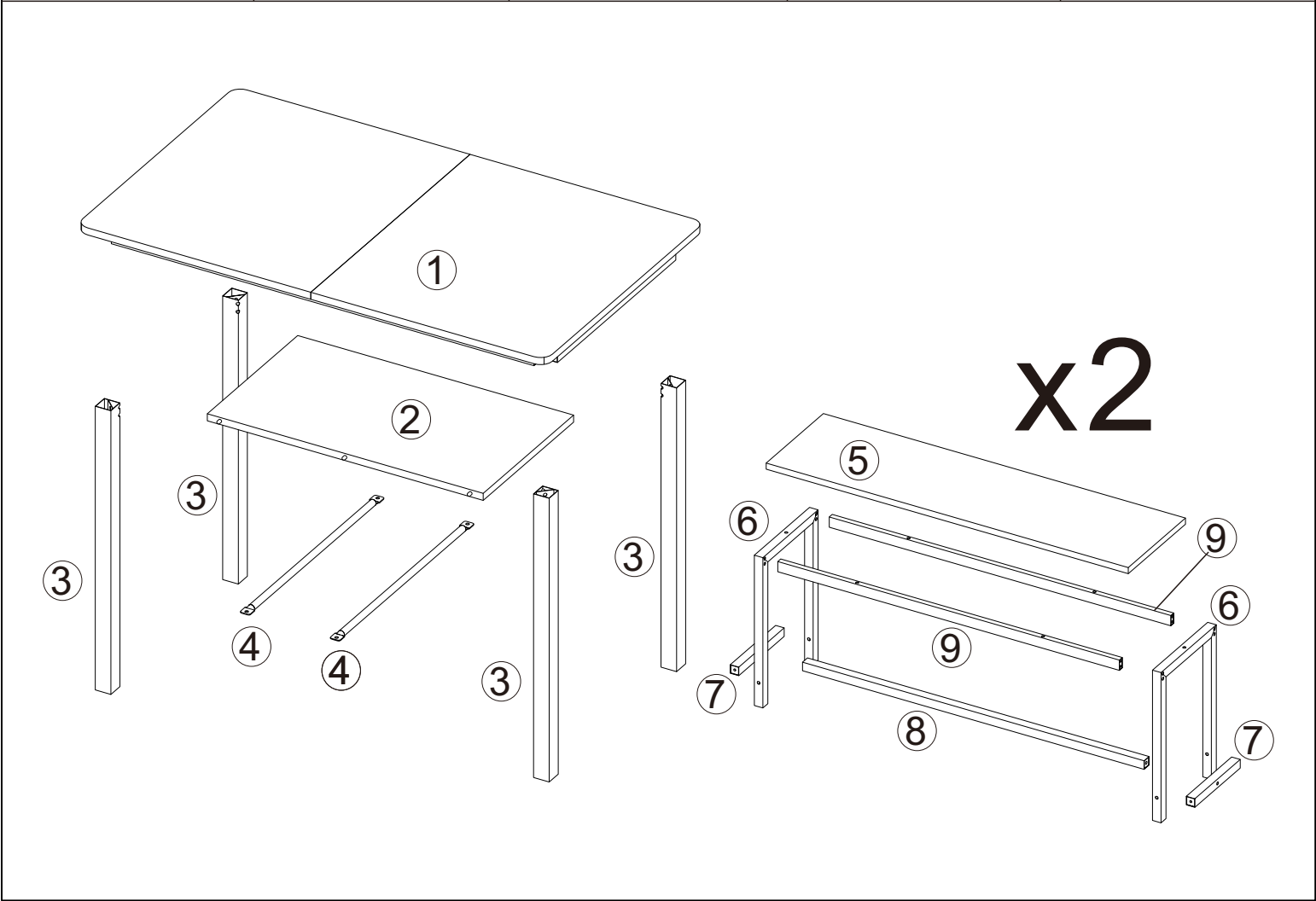
 <b>1</b> 1PC	 <b>2</b> 1PC	 <b>3</b> 4PCS	 <b>4</b> 2PCS	
 <b>5</b> 2PCS	 <b>6</b> 4PCS	 <b>7</b> 4PCS	 <b>8</b> 2PCS	 <b>9</b> 4PCS
 <b>A</b> M8x45mm 8PCS	 <b>B</b> $\Phi 16*\Phi 9*2\text{mm}$ 8PCS	 <b>C</b> $\Phi 13*\Phi 9*2\text{mm}$ 8PCS	 <b>D</b> M6x12mm 4PCS	 <b>E</b> M6x35mm 4PCS
 <b>F</b> M6x40mm 8PCS	 <b>G</b> M6x45mm 28PCS	 <b>H</b> D4 1PC	 <b>I</b> D5 1PC	



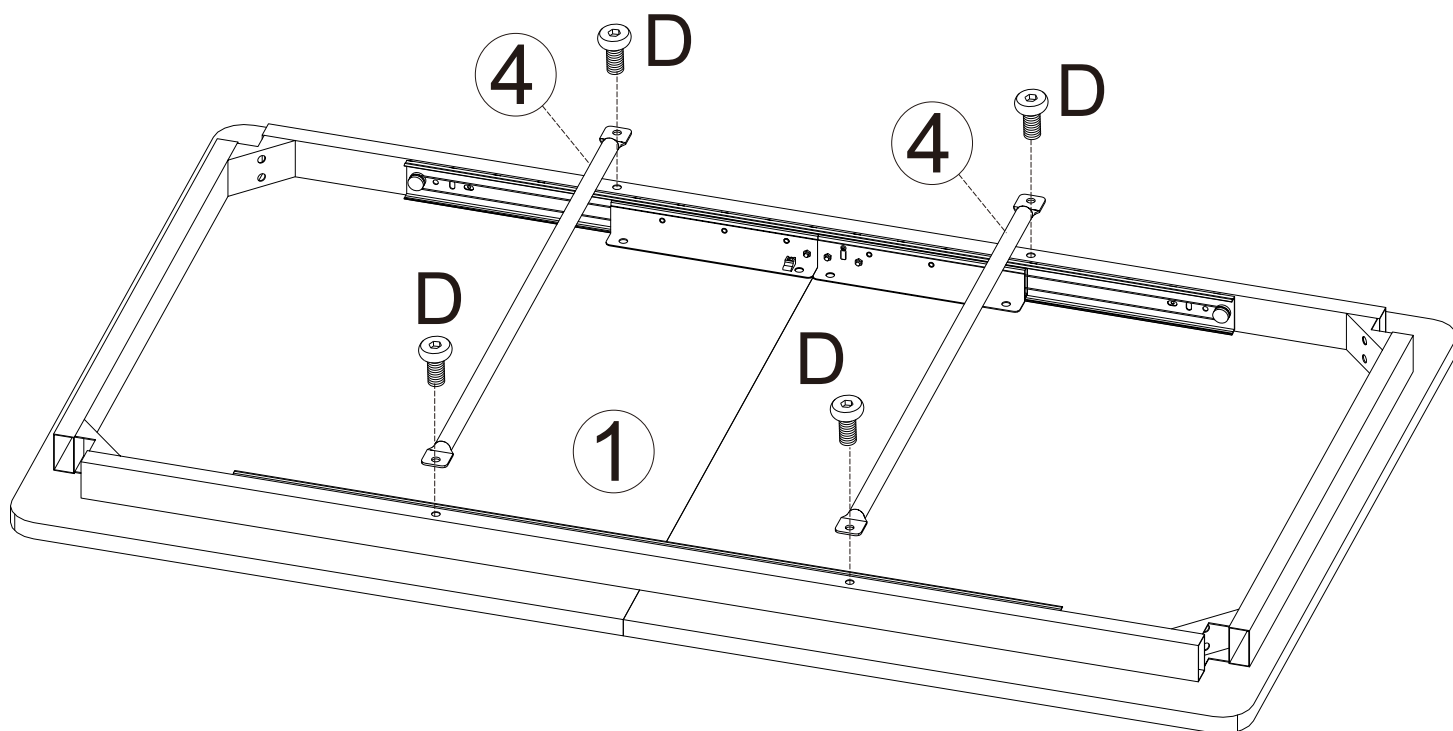



# STEP 1

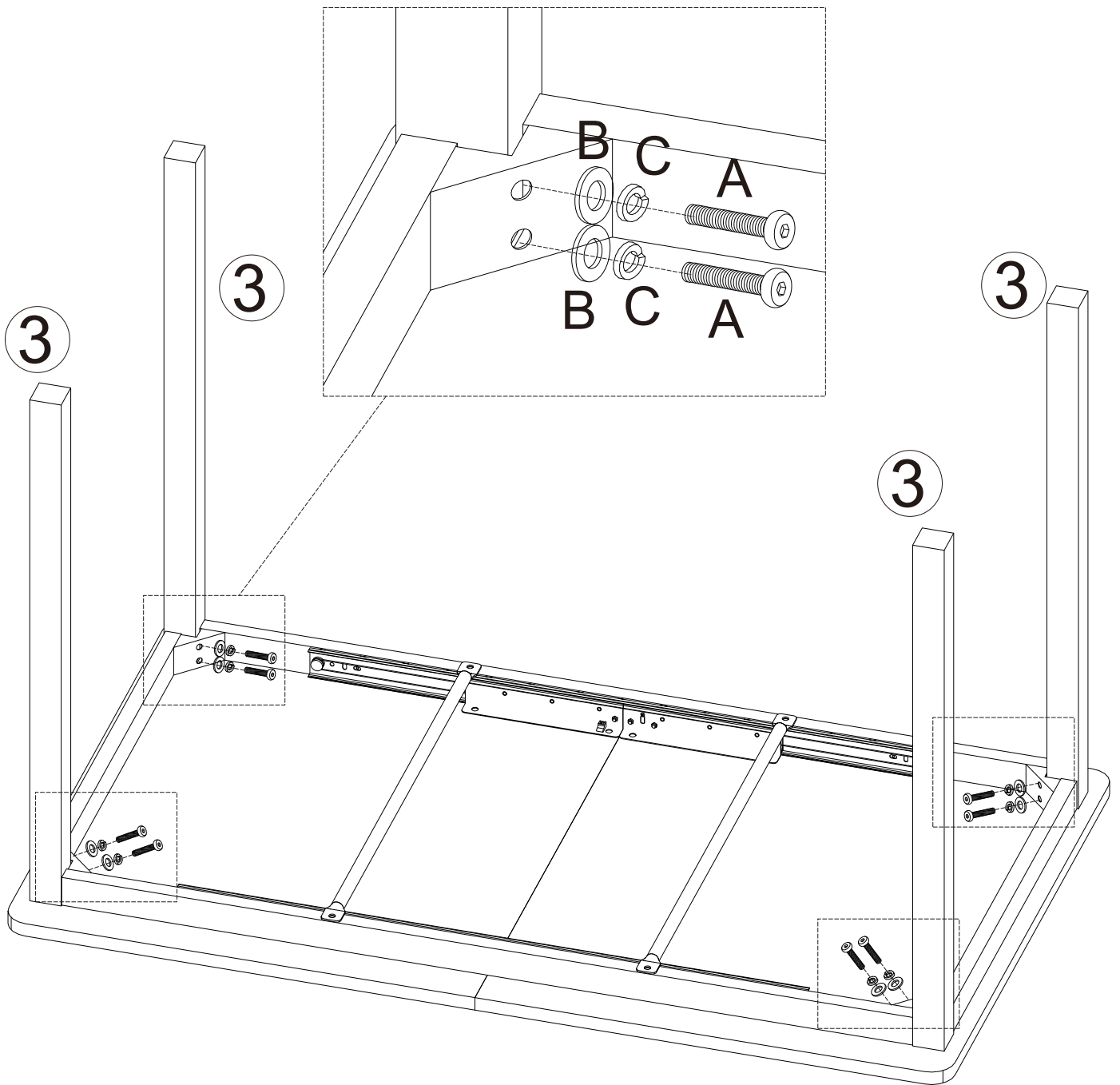

CODE	HARDWARE	QTY
D	 M6x12mm	4
H	 D4	1

# STEP 2



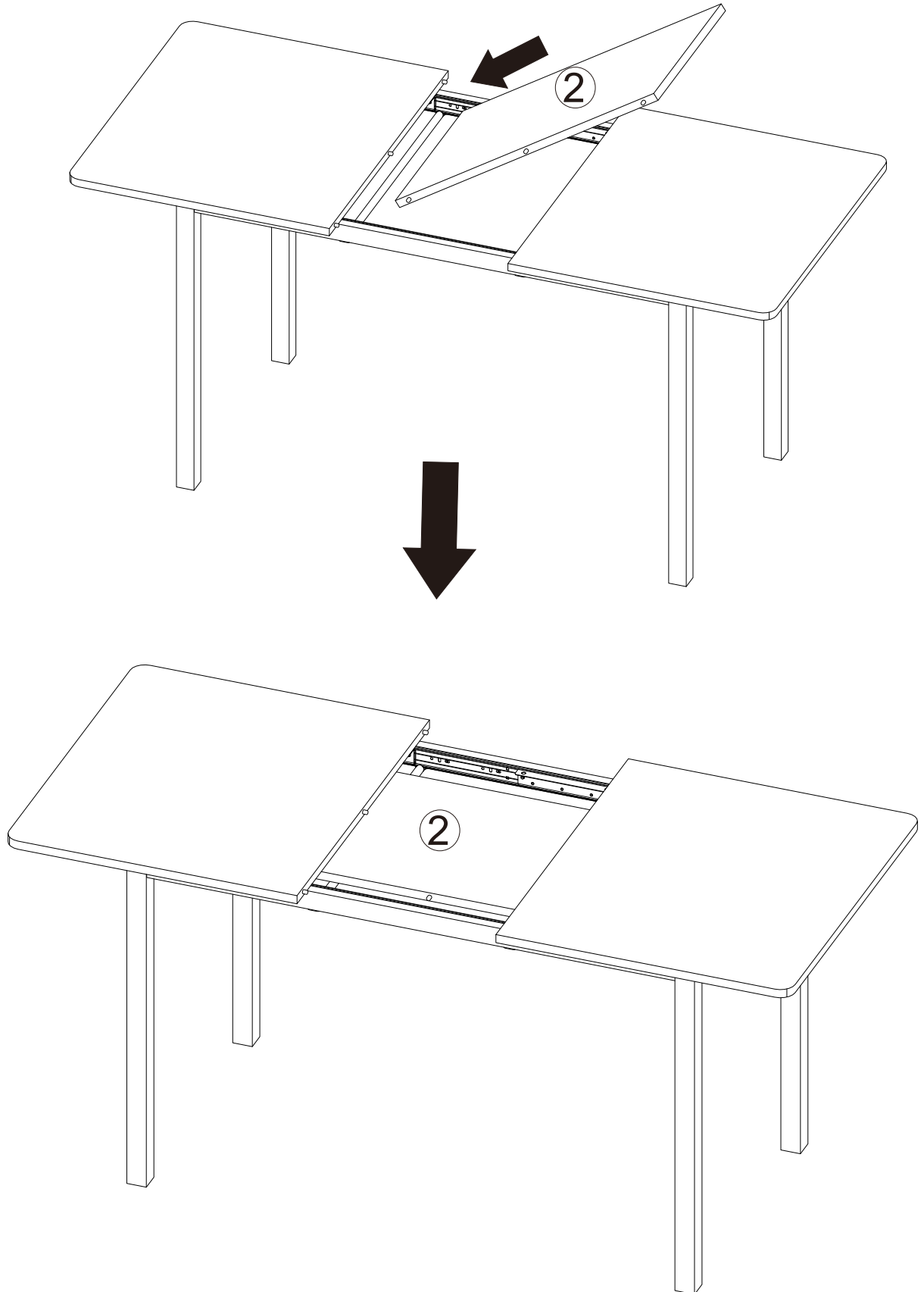

CODE	HARDWARE	QTY
A	 M8x45mm	8
B	 $\Phi 16^* \Phi 9^* 2\text{mm}$	8
C	 $\Phi 13^* \Phi 9^* 2\text{mm}$	8
I	 D5	1

# STEP 3

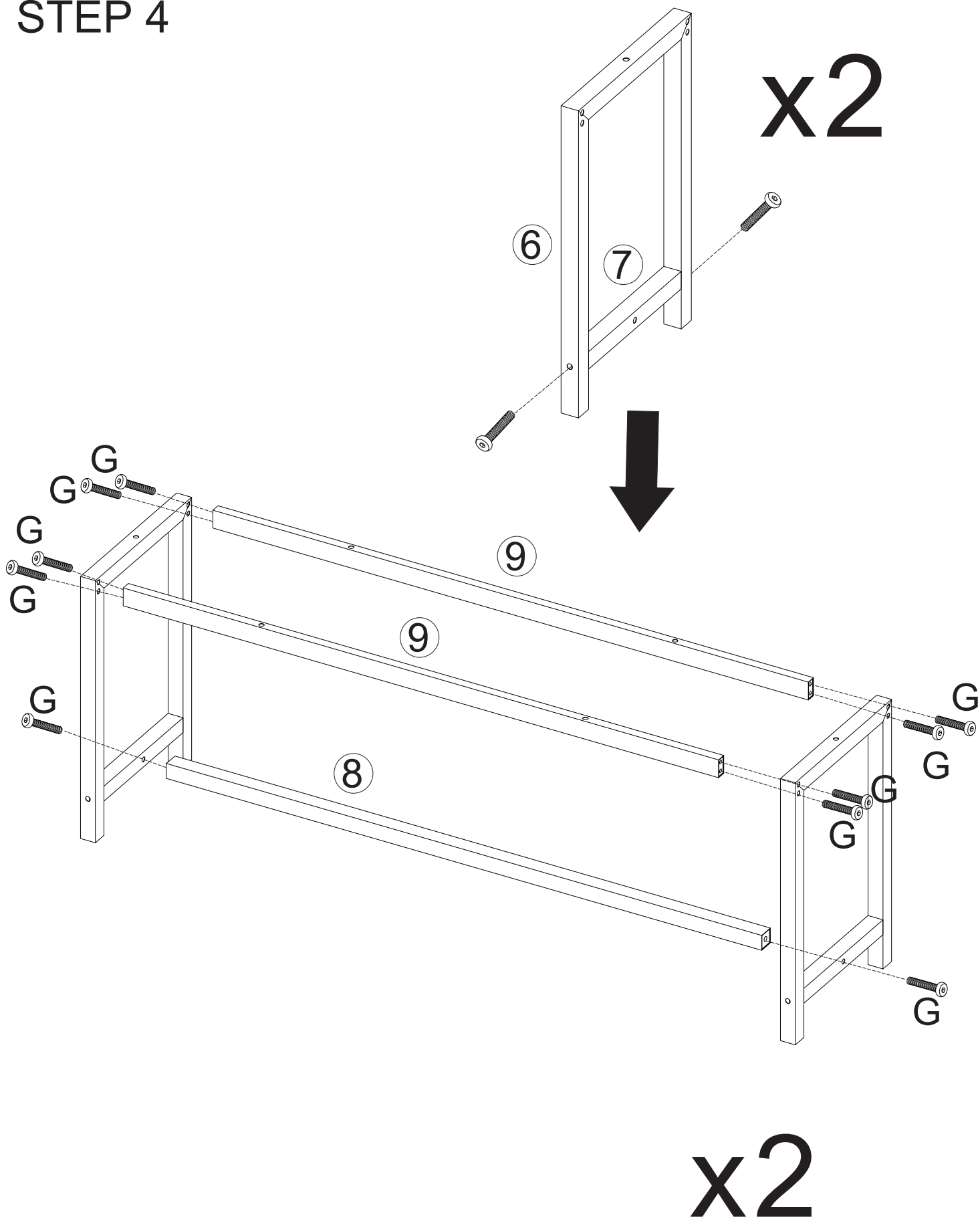

# STEP 4

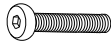

CODE	HARDWARE	QTY
G	 M6x45mm	28
H	 D4	1

# STEP 5

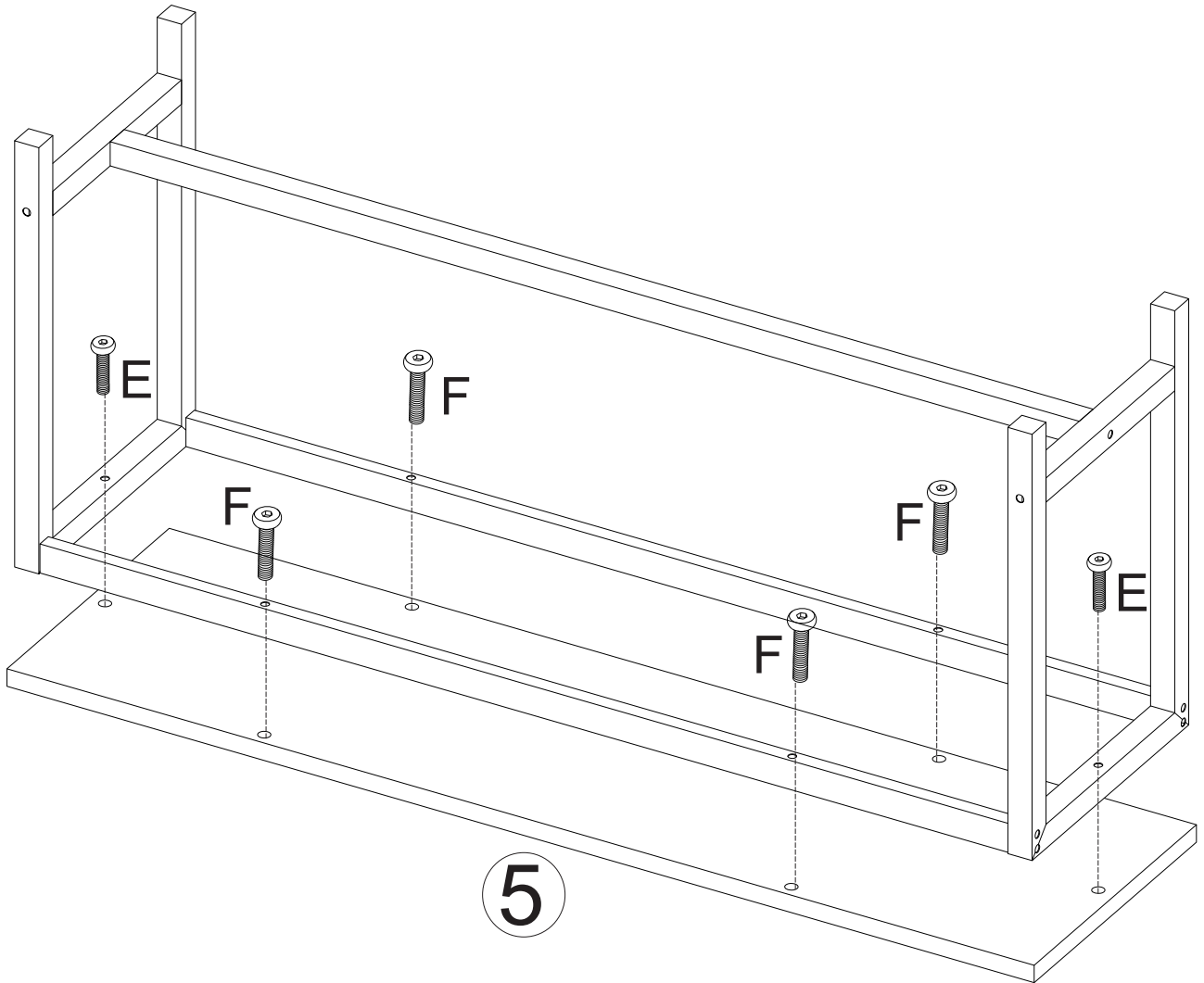

# x2

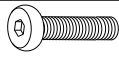
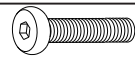
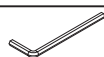
CODE	HARDWARE	QTY
E	 M6x35mm	4
F	 M6x40mm	8
H	 D4	1

# STEP 6

