

# Assembly Instructions

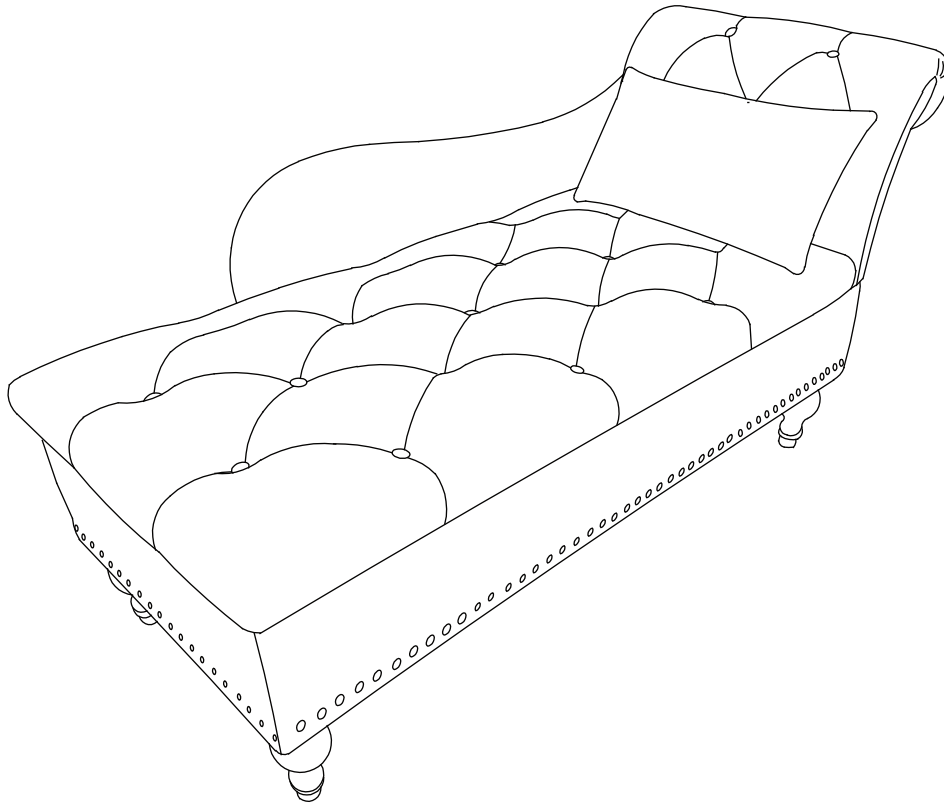

**ITEM NO. E044-001-001**

**NOTE:** Please read these instructions carefully before starting assembly

## HASSEL-FREE WARRANTY

We proudly provide 1-YEAR warranty, if there are any questions with the products, please feel free to contact with us.

Email: [furniture01service@gmail.com](mailto:furniture01service@gmail.com)



The assembly will be easier with 2 people while 1 person could also do the job.



**Around 10 MIN ASSEMBLY**

# MAINTAINANCE AND WARNING



- Keep furniture away from heat sources.
- Do not clean furniture with harsh cleaner or polishes. Do not use detergents, Solvents, abrasives, spray packs or leather cleaner. Use non-color mild soap with warm water to clean spills(Mix 1:10 soap to water)
- Do not place furniture under direct sunlight, material will possibly fade over time.
- Do not use on site dry Cleaning machine.
- Children should not climb or jump on the furniture.
- Do not write on furniture that is not protected by a padded barrier .



Weight Limitation

**250LBS**

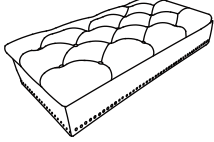
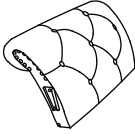
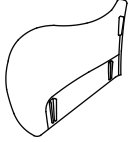
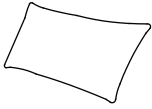
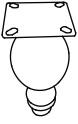
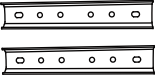
# PART LIST & HARDWARE

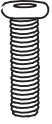
<b>A</b> Seat frame  1PC	<b>B</b> Backrest  1PC	<b>C</b> Handrail  1PC	<b>D</b> Pillow  1PC
<b>E</b> Supporting feet  4PCS	<b>F</b> Inserts  2PCS	<b>G</b> Alley Key  1PC	<b>H</b> M6*20mm  16PCS

# ASSEMBLY INSTRUCTIONS

Step 1: Assemble the supporting feet (E) like below pictures.

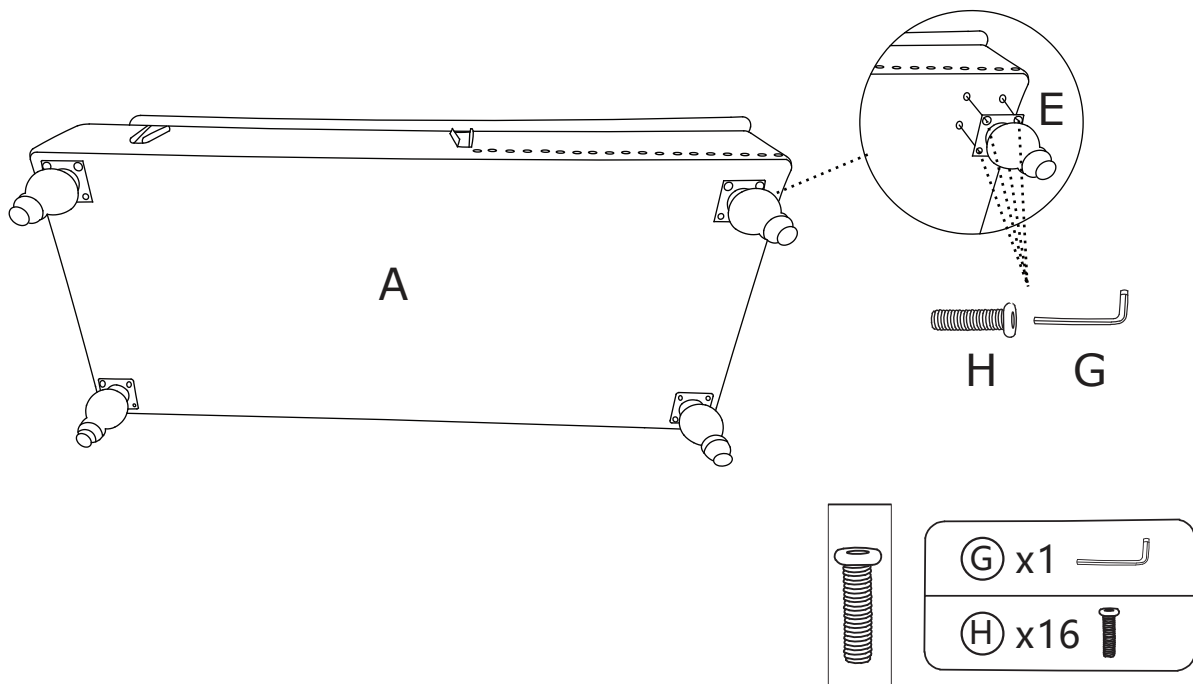

Step 2: Install the inserts (F) on the backrest (B).

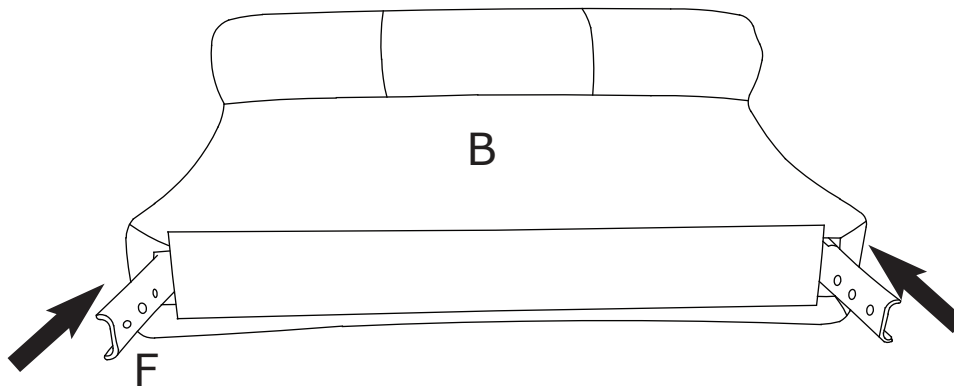

Step 3: Pick up the backrest and insert it into the hole behind the cushion.

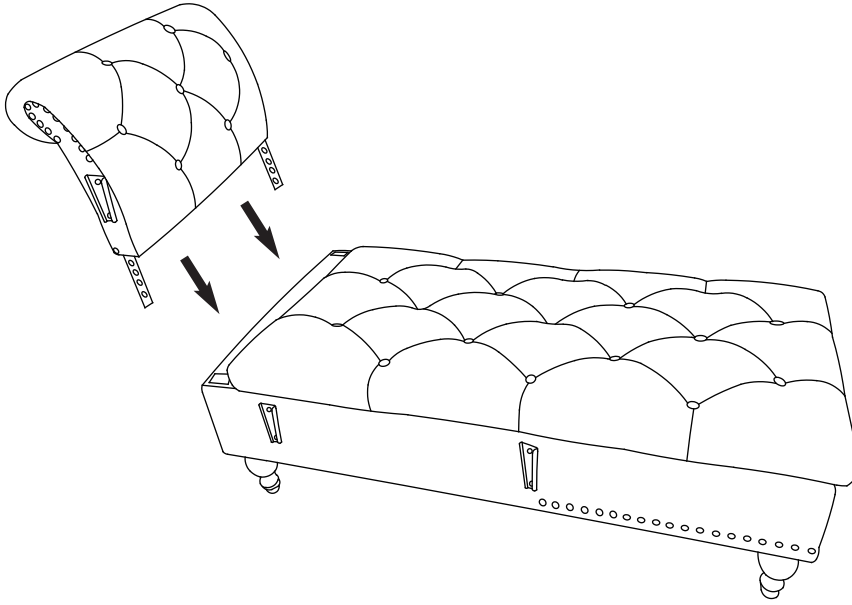

Step 4: Insert the armrest (C) from top to bottom onto one side of the seat cushion.

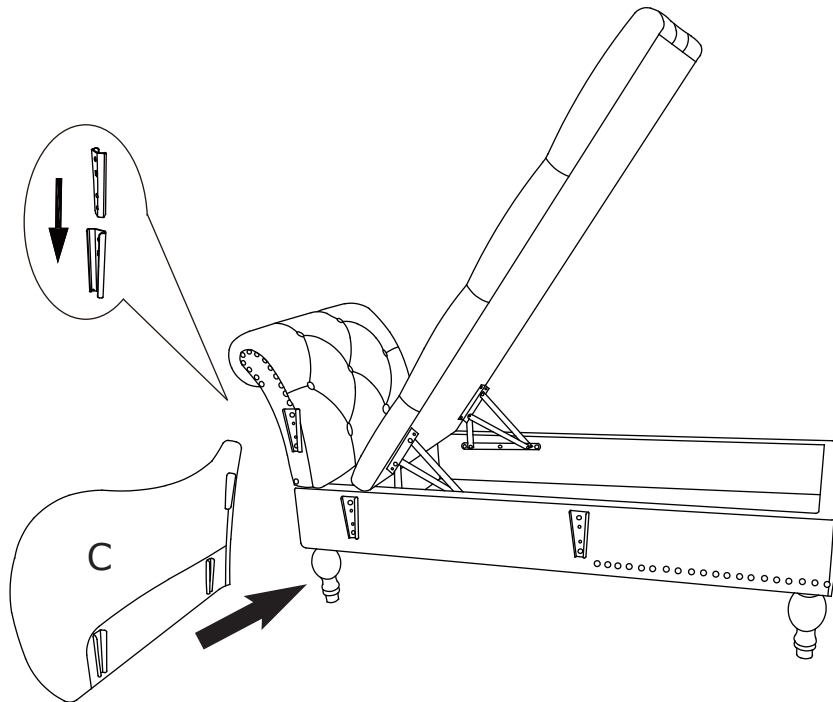

Step 5: Put on the pillow (D).

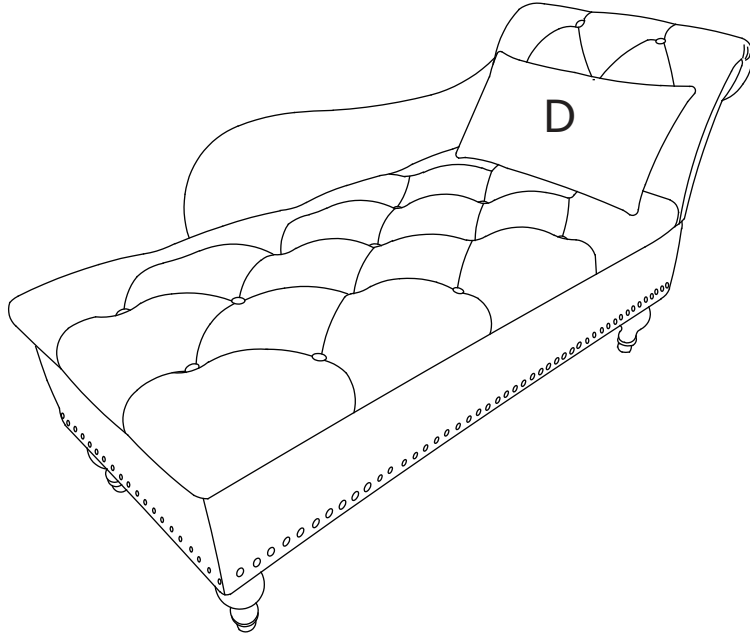

# **WARRANTY**

We strive to offer high-quality products, and we also try our best to satisfy each and every customer that orders from us with product or service as needed. We provide 1 year warranty starting from the time you receive the item. Each customer must provide a record of their order such as the order number, or item receipt for any items that are out of the warranty period, you may also still receive replacement parts by purchasing them with our company if they are available.

**Are you having difficulty  
with assembly? Missing parts?**

**Please send email with your order No to  
[furniture01service@gmail.com](mailto:furniture01service@gmail.com)**

**For return, please check the return policy with  
the retailer or market place you bought from.**

**Appreciate your purchasing from us.  
Pop up your life by our furniture piece!**