

Assembly Manual / Guide d'assemblage /
Manual de ensamblaje / 조립 설명서 /
Montageanleitung

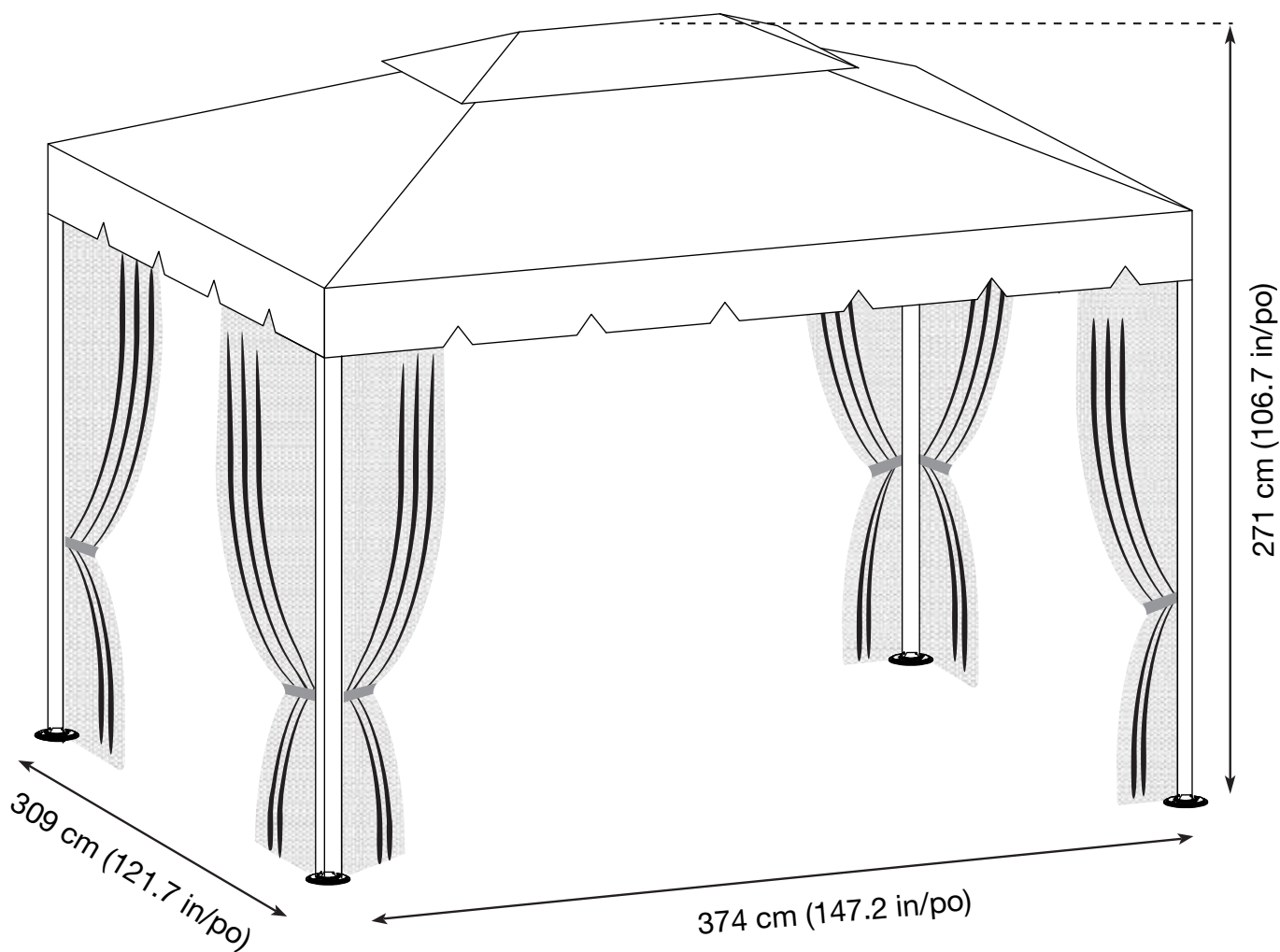

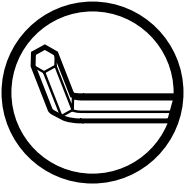

Use the hex keys in the box. / Utilisez les clés hexagonales fournies dans la boîte. / Utilice las llaves hexagonales en la caja. / 상자에 육각 키를 사용 하십시오. / Verwenden Sie die Sechskantschlüssel in der Box.

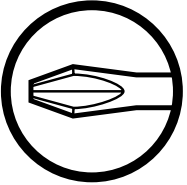

Please use a phillips screwdriver / Utilisez un tournevis de type Phillips / Por favor, use un destornillador Phillips / 십자 드라이버를 사용 하십시오. / Bitte verwenden Sie einen Kreuzschraubenzieher.

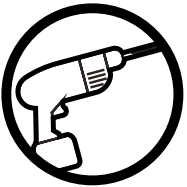

you may need to use a drill for this step. / vous pouvez avoir besoin d'utiliser une perceuse pour cette étape. / puede que tenga que utilizar un taladro para este paso. / 이 단계에선 드릴을 사용해야 할 수도 있습니다. / Für diesen Schritt können Sie einen Bohrer verwenden.



It is recommended to wear protective gloves / Le port de gants de protection est recommandé / El uso de guantes de protección se recomienda / 보호 장갑을 착용 하는 것이 좋습니다. / Das Tragen von Schutzhandschuhen wird empfohlen.



Two or more people are required at this stage. / Deux personnes ou plus sont nécessaires à cette étape. / Dos o más personas se requieren en esta etapa. / 이 단계에서는 두 명 이상이 필요합니다. / Für diesen Bauschritt sind 2 oder mehr Personen erforderlich.



Do not screw firmly for now. / Ne pas visser fermement pour l'instant. / No atornille con firmeza por ahora. / 아직 나사를 단단히 조이지 마십시오. / Bitte die Schrauben zum jetzigen Zeitpunkt noch nicht fest anziehen.



Sold in options / Vendus en options / vendido en las opciones / 옵션 판매 / Optional erhältlich

O X8(+1)



N X40(+4)

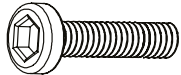

Q X8(+1)



P X24(+2)

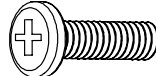

R X1

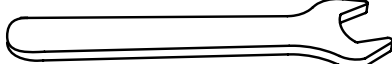

S X1

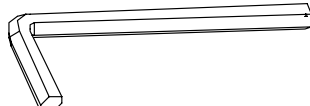

A X4



B X2

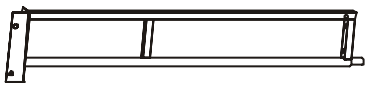

B1 X2



C X2

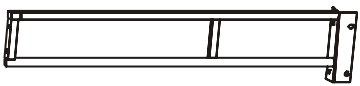

C1 X2

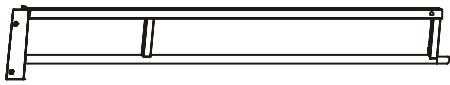

D X4



E X4



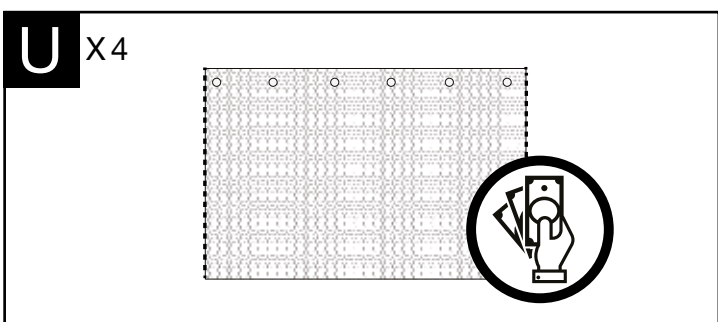
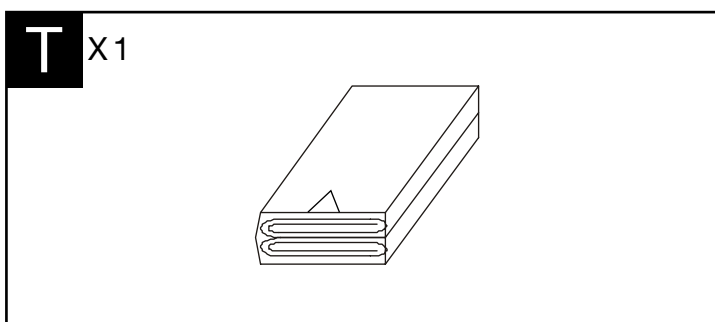
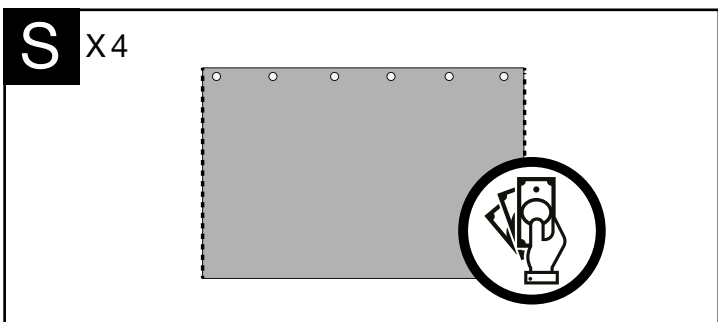
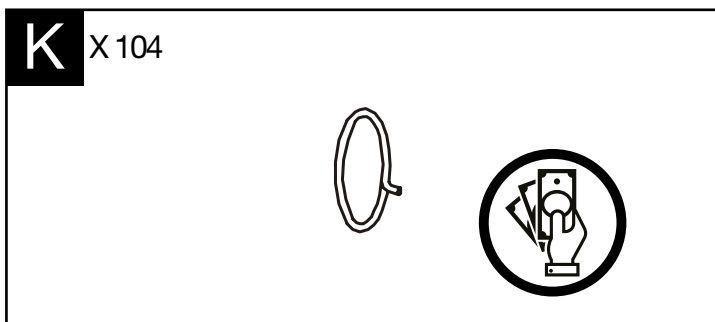
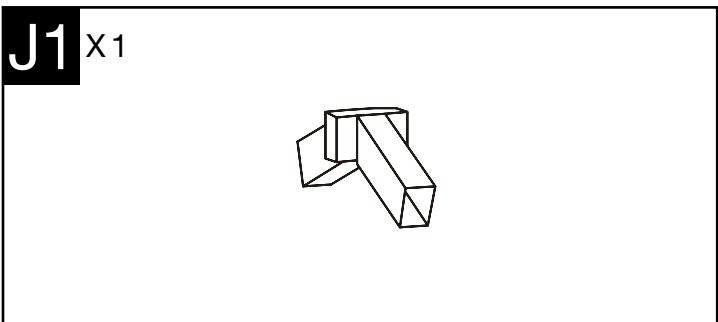
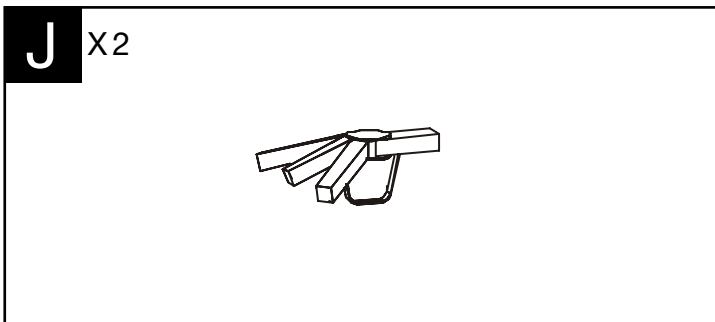
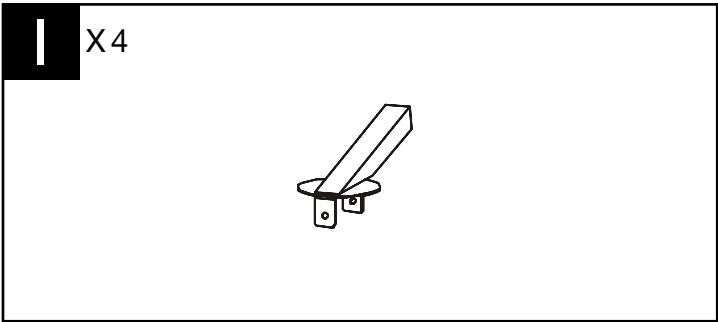
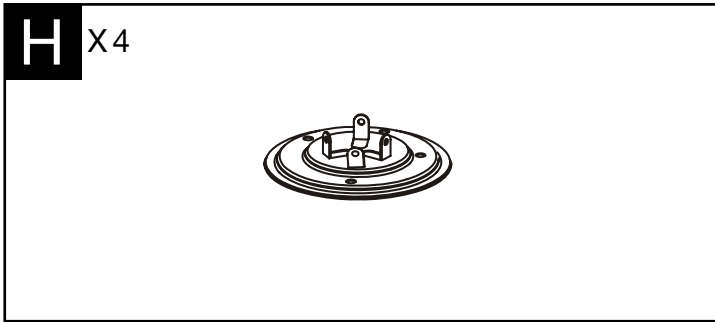
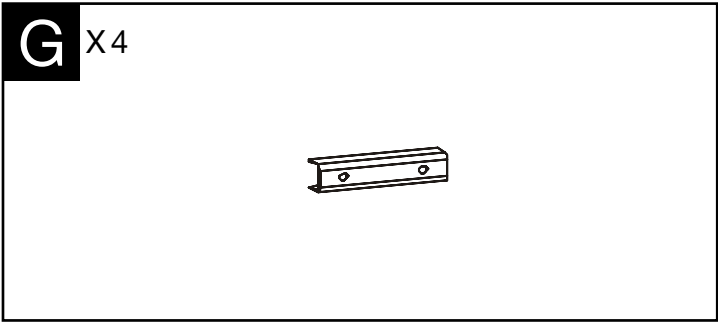
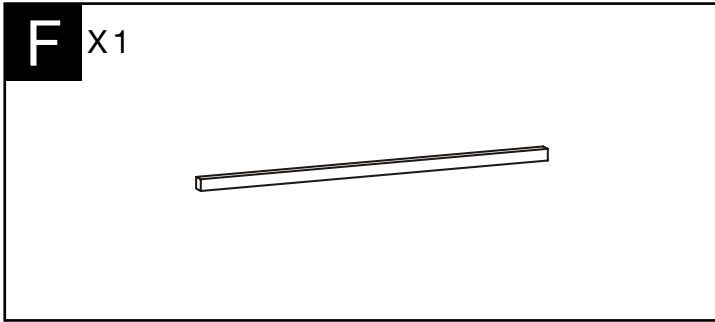

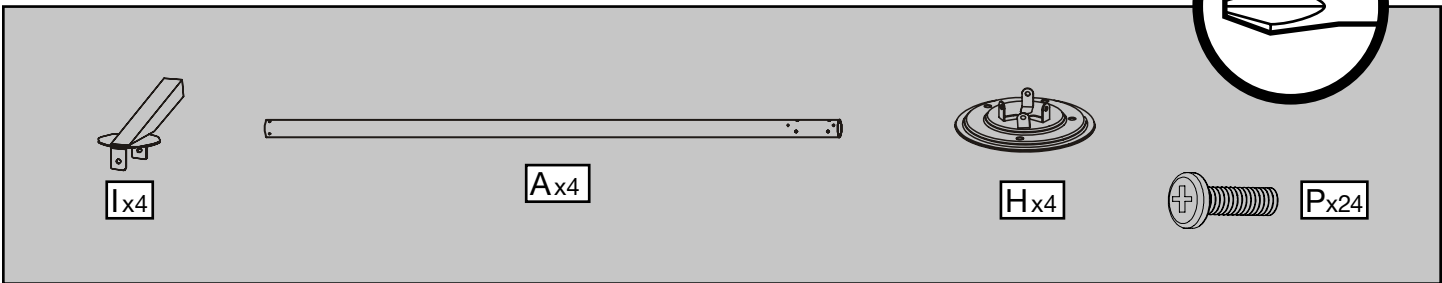
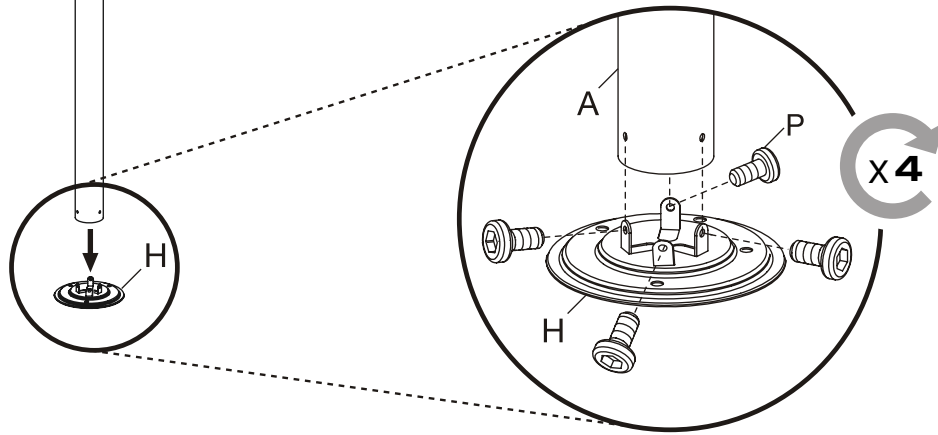
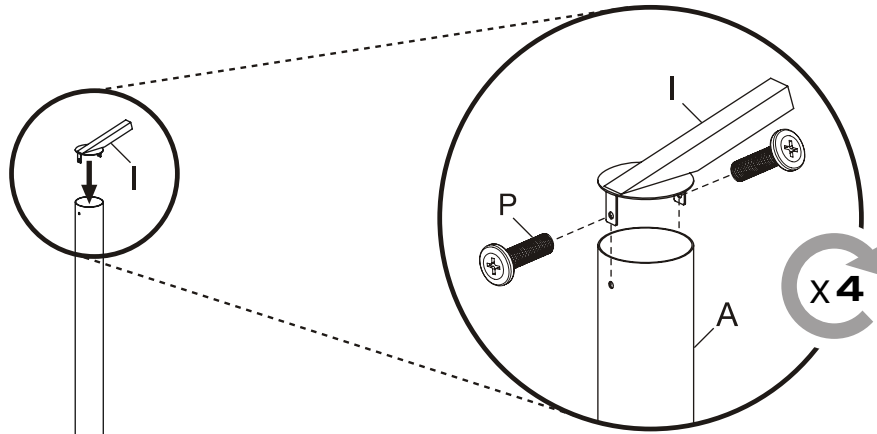

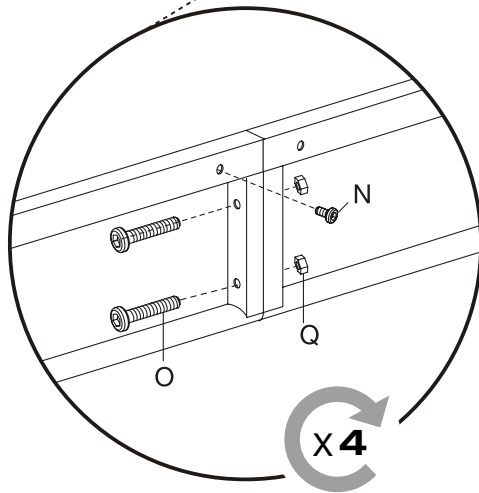
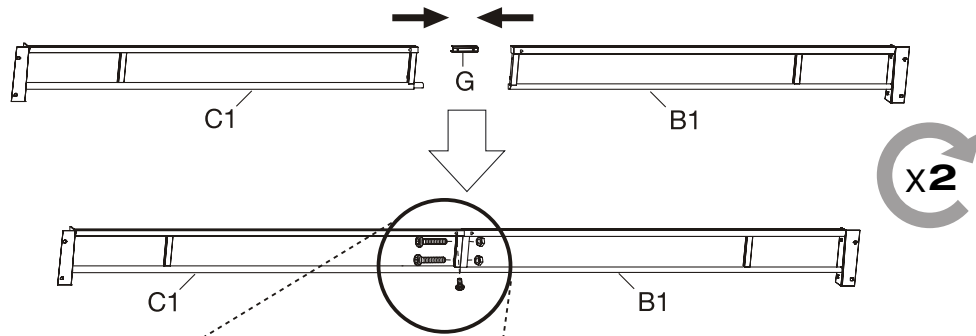
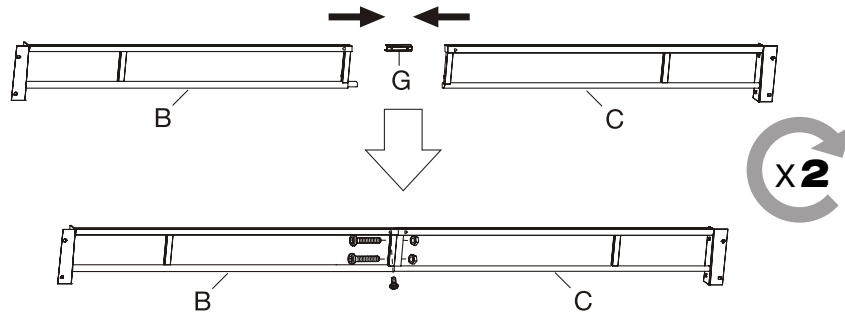

Parts list diagram showing the components for step 6:

- Bx2
- Cx2
- B1x2
- C1x2
- Gx4
- Nx4
- Ox8
- Qx8

A circular icon with an Allen key is also present.

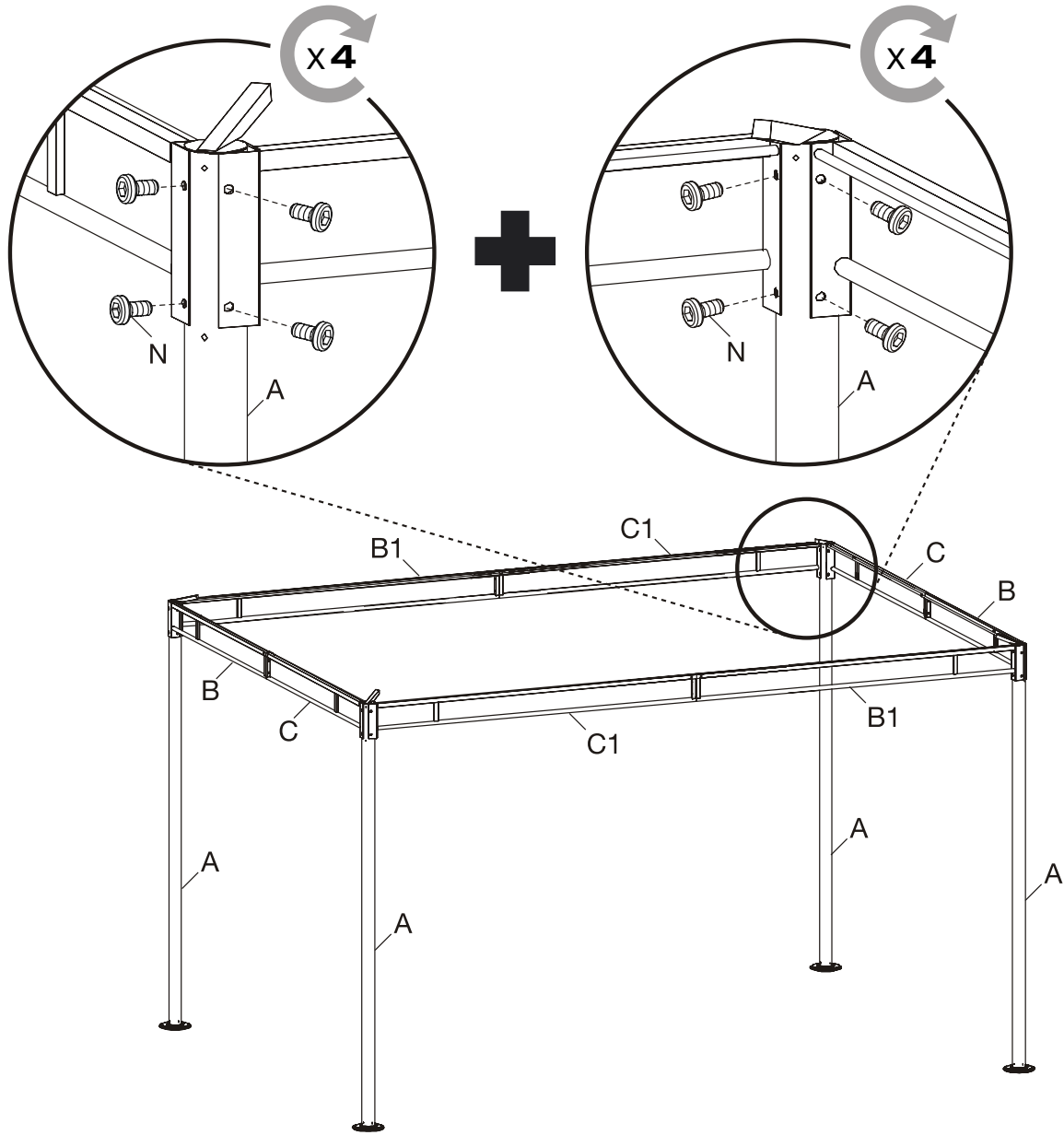

This section contains the material list and icons for step 3/7. On the left, a single bolt is shown with the label 'Nx32' below it. To the right of the bolt are two circular icons: the first shows two stylized human figures with the text '2+' below them, indicating that two people are required for assembly; the second shows a hex key (Allen key) being used to tighten a bolt.

