

# ASSEMBLY INSTRUCTIONS

Thank you for purchasing the quality product. Be sure to check all packing material carefully for small parts which may have come loose inside the carton during shipment. Separate, identify and count all parts and metal hardware. Compare with all parts list to be sure all parts are present. If any part (s) are missing or damaged, please contact your local furniture dealer. For efficient and speedy service, please indicate the model number and code letter of part (s) needed.

**\*\*\*Do not fully tighten bolts and screws until fully assembled\*\*\***

## PART LIST :

PART#	DESCRIPTION	QTY
1	Dresser	1
2	Bun Foot	4
3	Glass Top	1
4	Support Leg with Plastic Washer & Adjuster	1

**NOTE: HANDLE FRAGILE GLASS TOP WITH CARE**

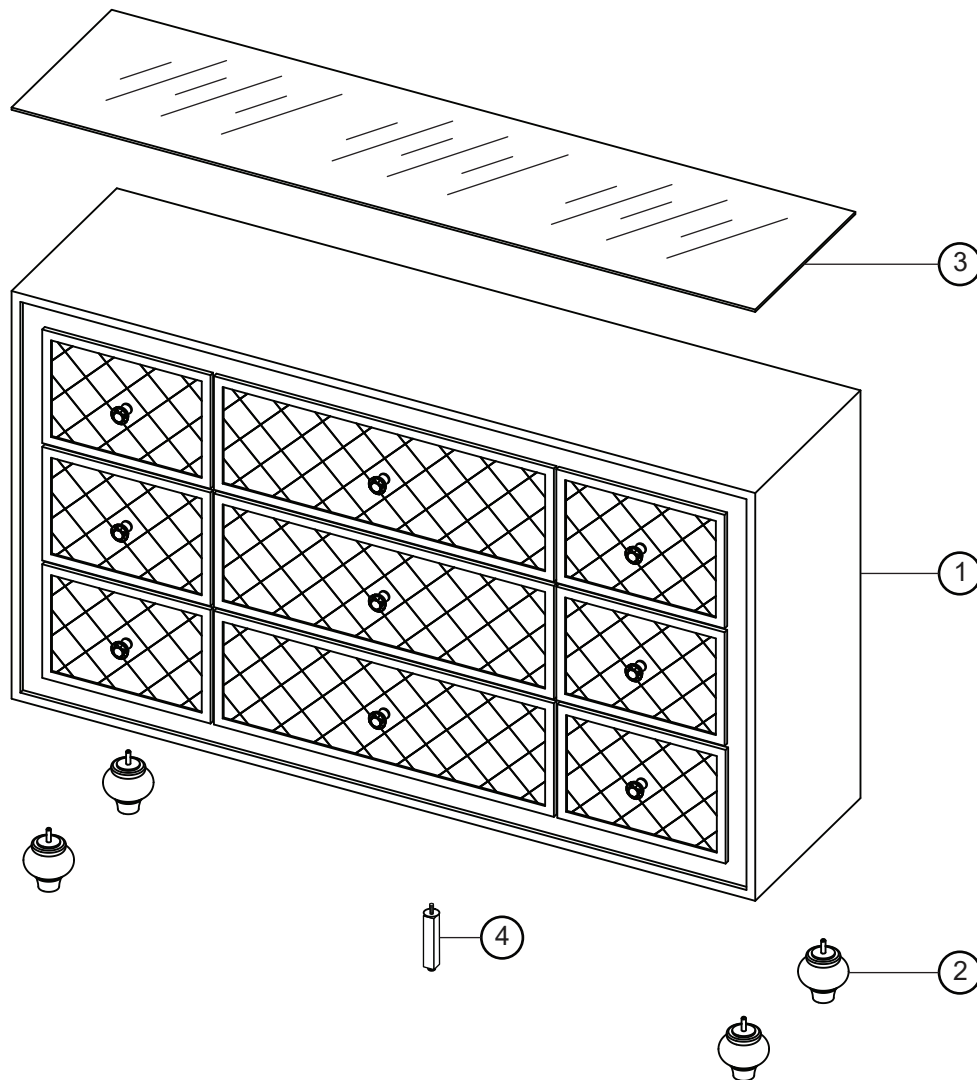

## Attention:

\*\*\* Some number parts listed on the instruction sheet may not be in parts bag as they may already be assembled. Carefully check parts and packing materials prior to ordering replacements.

# HOW TO ASSEMBLE :

## STEP: 1

Lift the Glass Top (3) gently and carefully place it at a safe area before assembly begin.

Remove Bun Foot (2) box located in the drawer of the casegood.  
Remove and unwrap each foot.

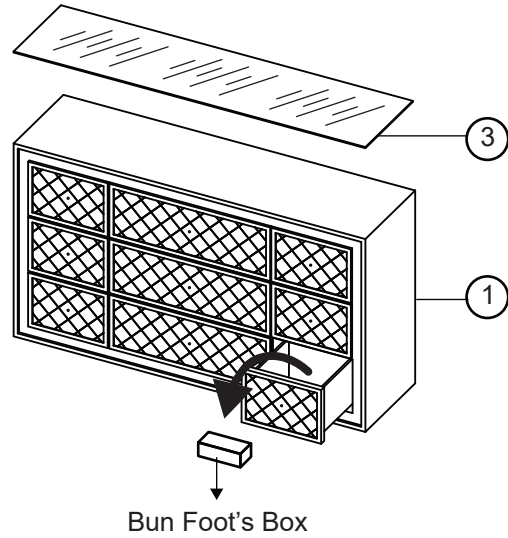

## STEP: 2

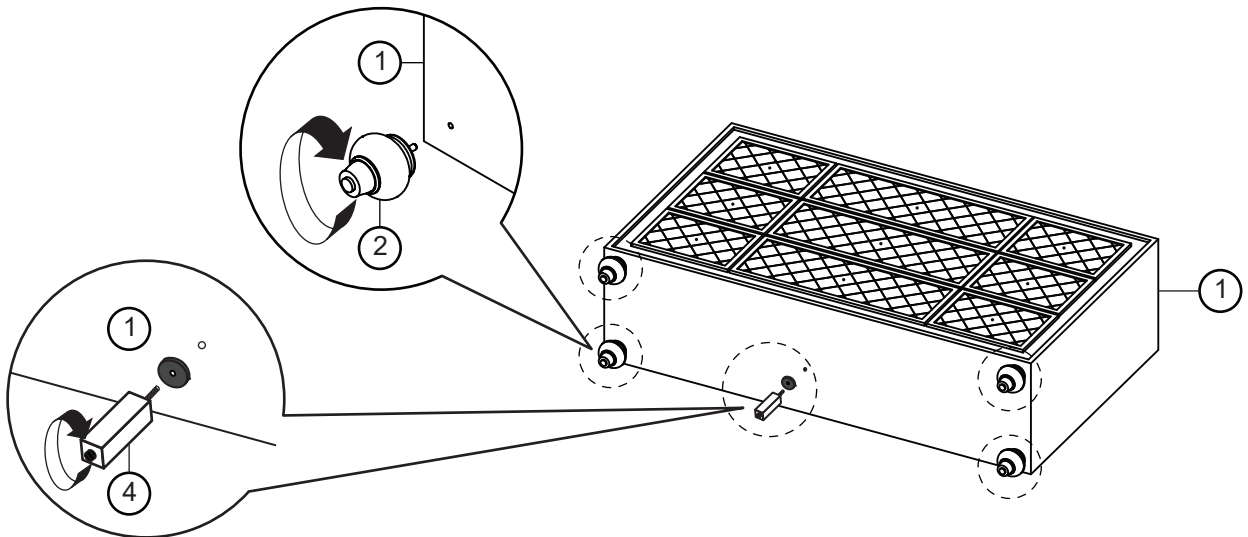

## STEP: 3

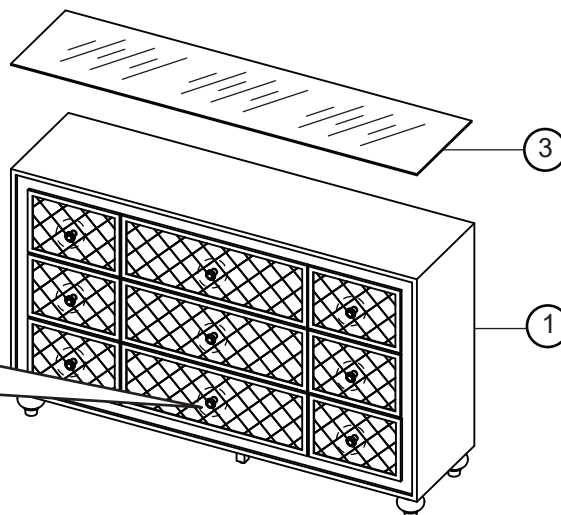
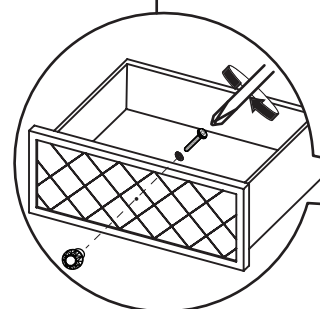
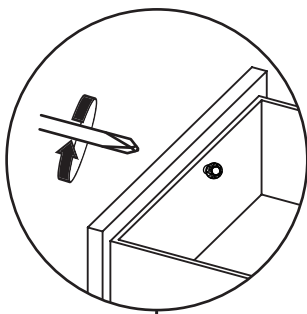

Place the Glass Top (3) to the top surface of Dresser (1).

**ASSEMBLY COMPLETE**

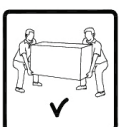

# ASSEMBLY INSTRUCTIONS

## ANTI-TIPPING INSTALLATION

Thank you for purchasing the quality product. Be sure to check all packing material carefully for small parts which may have come loose inside the carton during shipment. Separate, identify and count all parts and metal hardware. Compare with all parts list to be sure all parts are present. If any part (s) are missing or damaged, please contact your local furniture dealer. For efficient and speedy service, please indicate the model number and code letter of part (s) needed.

**\*\*\*Do not fully tighten bolts and screws until fully assembled\*\*\***

### PART LIST :

PART#	DESCRIPTION	QTY
1	Casegoods	1
2	Bracket	2
3	Strap	1
4	Long Screws 50mm	1
5	Short Screws 15mm	1

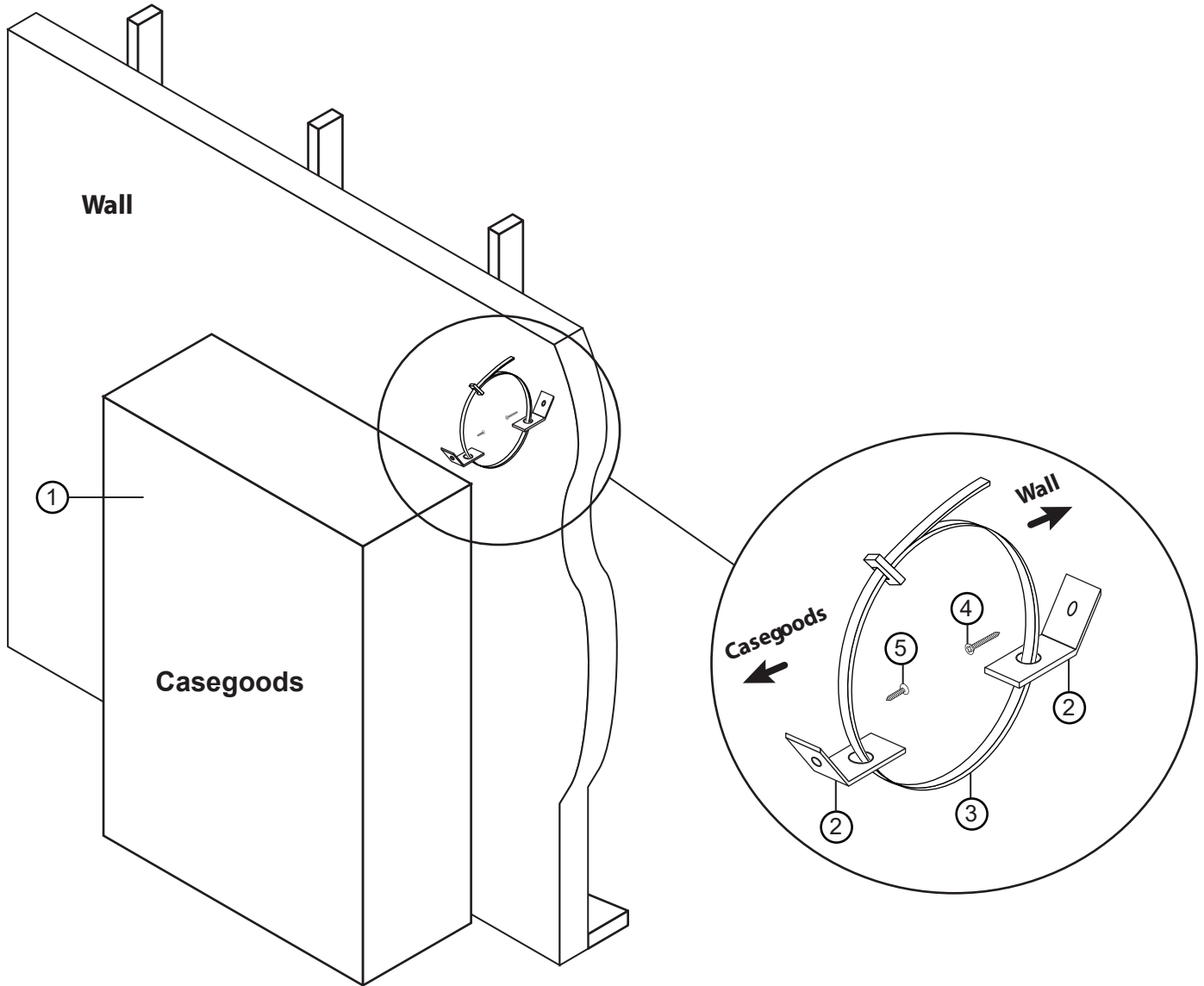

### **Attention:**

\*\*\* Some number parts listed on the instruction sheet may not be in parts bag as they may already be assembled. Carefully check parts and packing materials prior to ordering replacements.