

# ASSEMBLY INSTRUCTIONS

ITEM#N719P433676

N719P433677

N719P433678

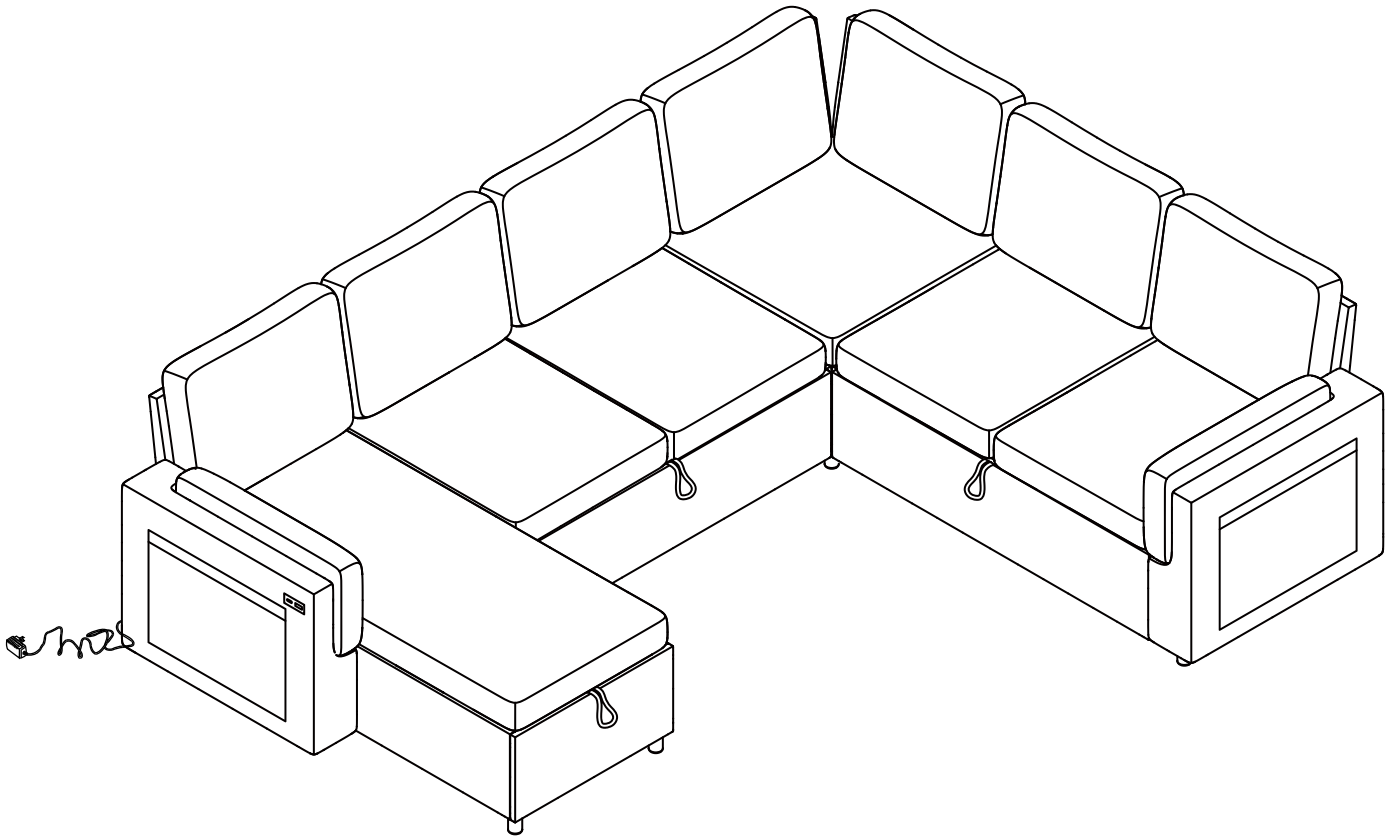

## IMPORTANT NOTE

**\*\*Place all parts on a lean and smooth surface such as a rug or carpet to avoid the parts from being scratched.**

**\*\*Before you begin, please review the assembly instruction step by step.**









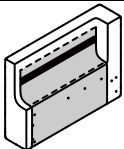
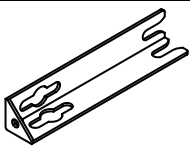
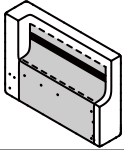

**\*\*Return & Warranty Policy:**

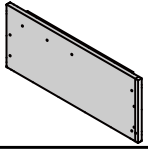

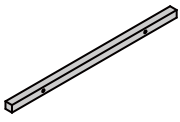
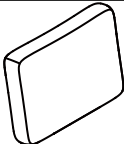
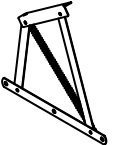
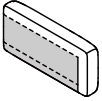
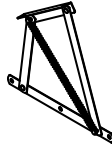
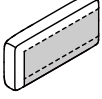
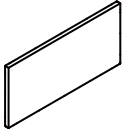
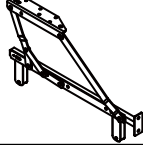
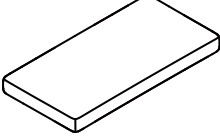
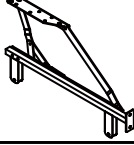
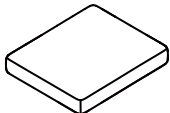
**-We strive to offer the highest quality products. We also provide positive solutions with replacements or refund if needed.**

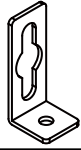
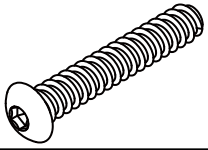
**-If the item is damaged or defective, please take photos to show the problem and email to the seller.**

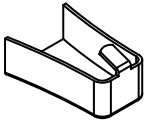
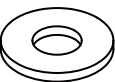
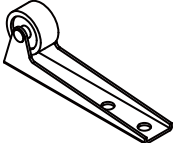
**-Please do not return back the product before contact the seller.**

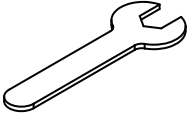

# PART LISTS BOX 1:N719P433676

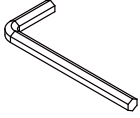
Part NO.	Part Image	Part Name	QTY	Part NO.	Part Image	Part Name	QTY
A		Left Armrest	1	V5		Connect Iron	14
B		Right Armrest	1	V6		Baseboard foot	6
G		Panel of Corner	1	V7		Plug	1
K		Connect Metal of Pull Out Bed Seater	2	W		Back Cushion	1
R-L		Hinge	2	X-L		Left Arm Pillow	1
R-R		Hinge	2	X-R		Right Arm Pillow	1
P		Front Panel of Chaise	1	Y		Right Pull Out Bed Frame	1
U2		Pull Out Bed Seat Cushion	1	Z		Left Pull Out Bed Frame	1
U3		Seat Cushion	2	a		Screws M6x20mm	90
V1		Hanger angle iron	6	b		Screws M6x35mm	16
V2		leg	10	c		Power Cord	9
V3		Limit Device	2	d		Gasket	20
V4		Draw String	2	e		Screw M4*10	4

Part NO.	Part Image	Part Name	QTY
f		Gasket	1
g		M4 Allen Key	1
h		M6 Allen Key	1

Part NO.	Part Image	Part Name	QTY

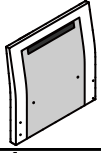
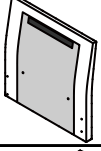
### PART LISTS BOX 2:N719P433677

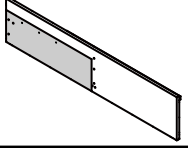
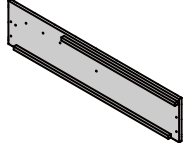
Part NO.	Part Image	Part Name	QTY
D		Corner Backrest	1
E		Corner Backrest	1
M		Backrest of Chaise	1
N-L		Side Panel of Chaise	1
N-R		Side Panel of Chaise	1

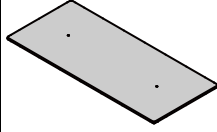
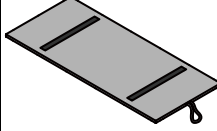
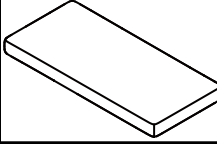
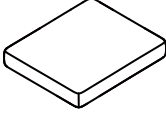
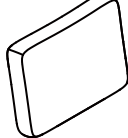
Part NO.	Part Image	Part Name	QTY
Q		Imperial Consort's Baseboard	1
T5		Imperial Consort's Seat	1
U1		Chaise Seat Cushion	1
U3		Seat Cushion	1
W		Back Cushion	4

### PART LISTS BOX 3:N719P433678

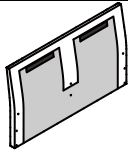
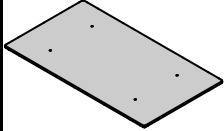
Part NO.	Part Image	Part Name	QTY
C		2-seater Backrest	2
F		Double-bottom plate	1

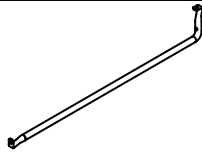
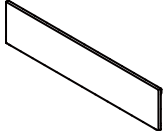
Part NO.	Part Image	Part Name	QTY
L		Connect Metal	1
S		Hinge	1

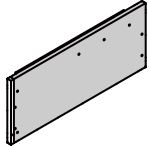
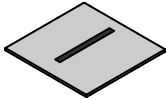
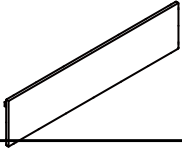
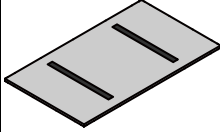
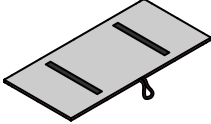
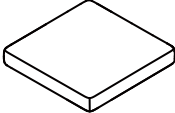
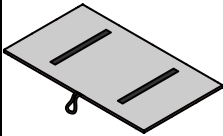
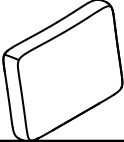
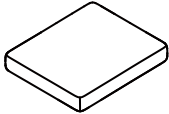
Part NO.	Part Image	Part Name	QTY	Part NO.	Part Image	Part Name	QTY
H		Panel of Corner	1	T1		Corner seat board	1
J		Front Panel of Pull Out Bed Seater	1	T2		Pull-out double-seat board	1
T3		Pulling bed base	1	U4		Corner Seat Cushion	1
T4		Two-person seat	1	W		Back Cushion	2
U3		Seat Cushion	1				

**Some parts are inside Armrest, please take them out**

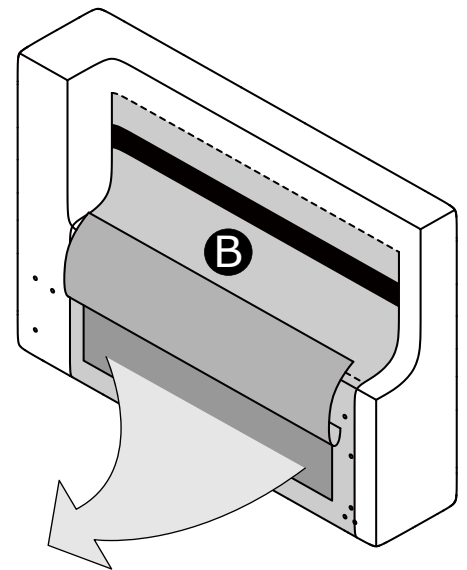
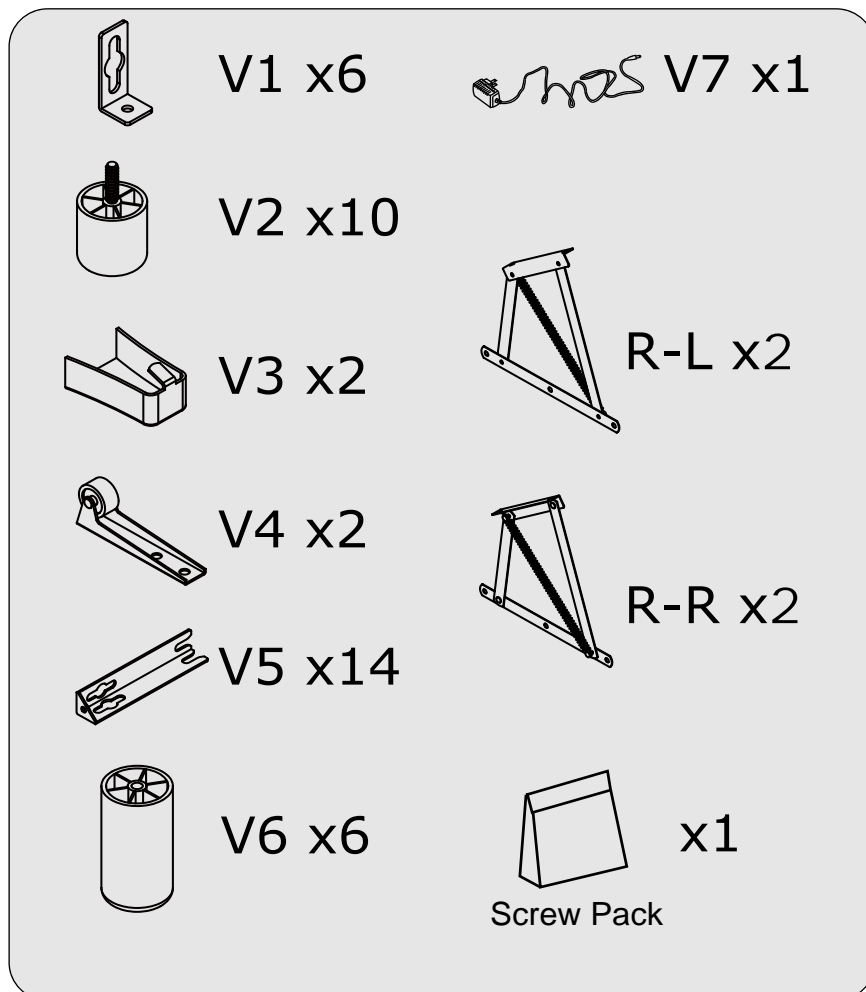
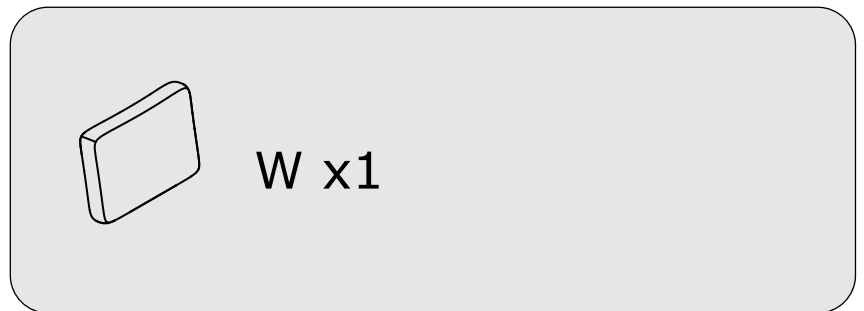
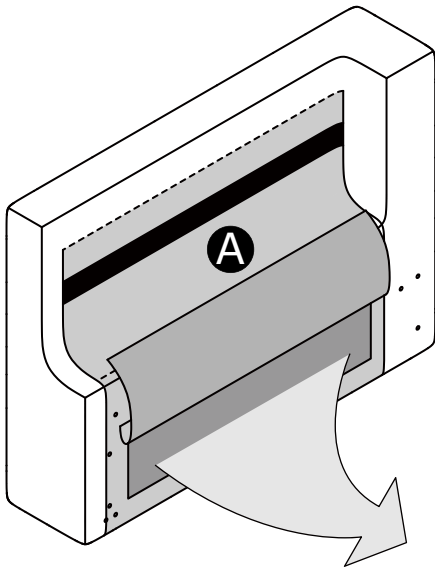

# CATALOG

2 Types Assembly Combination

Please choose one assembly combination first,  
then check corresponding page for assembling

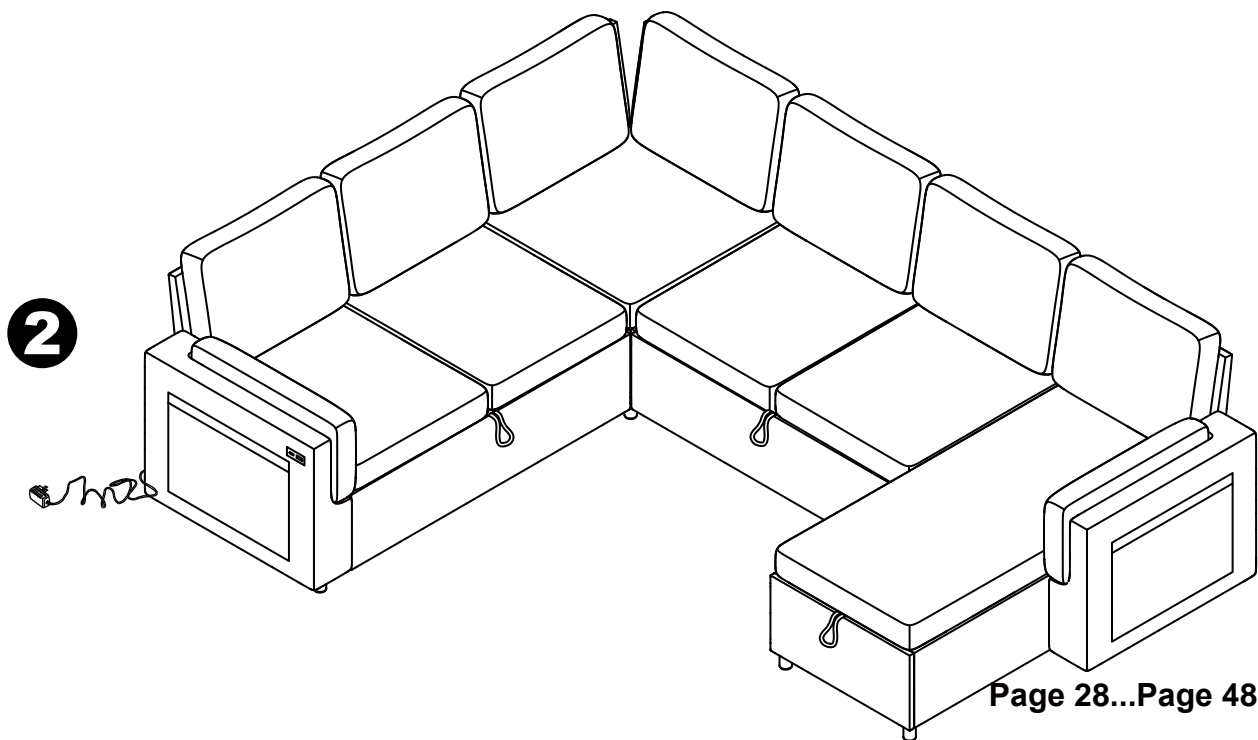
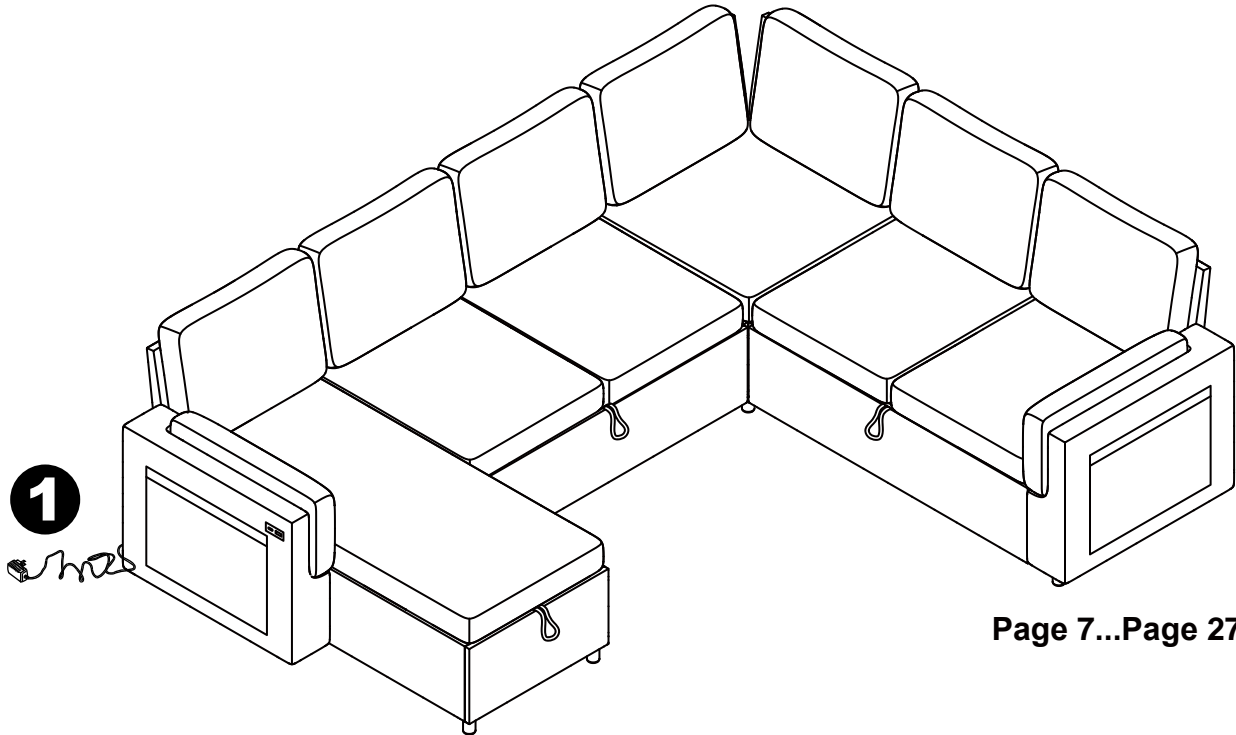

# 1 Sofa Overall Assembly Drawing

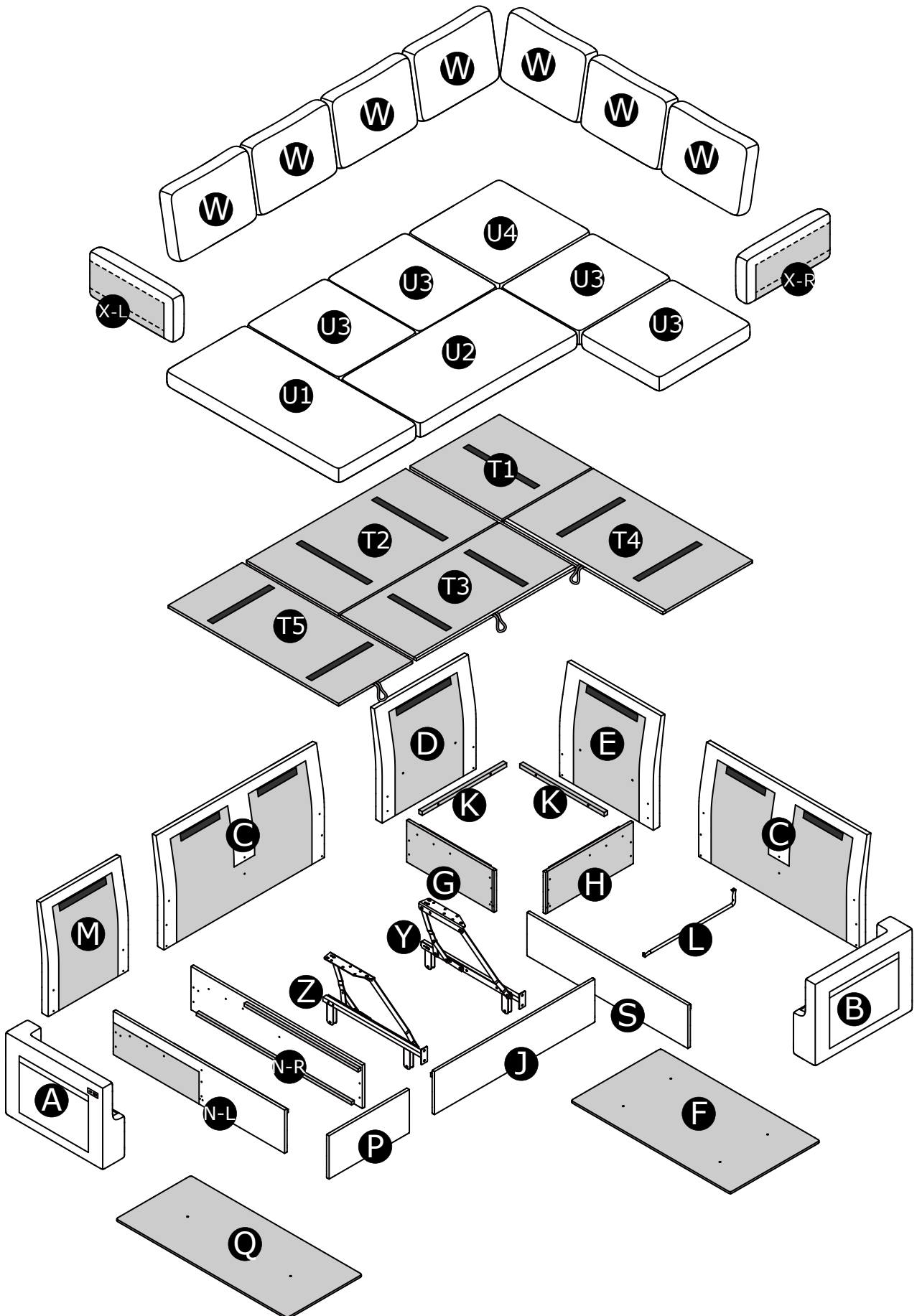

some parts are inside 2 armrests, please take some out

## STEP 1

**H** x1

**G** x1

**V5** x3

**b** x6

**h** x1

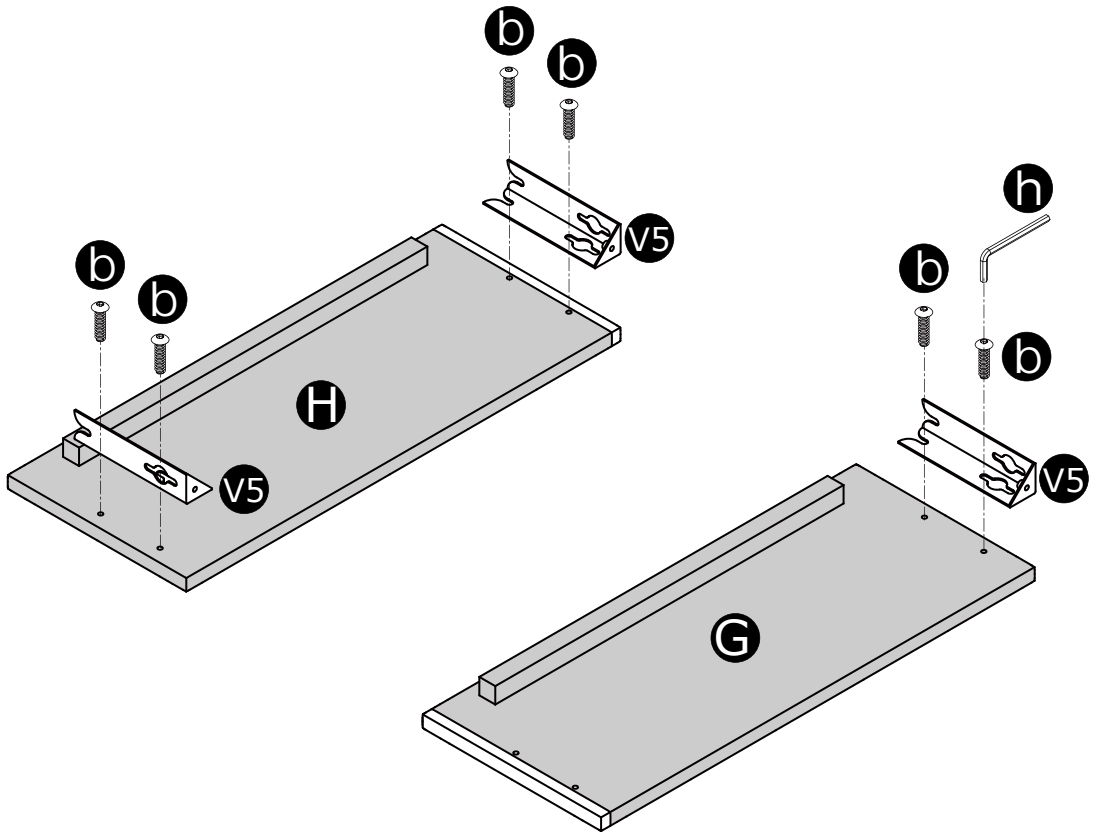

## STEP 2

**a** x2

**h** x1

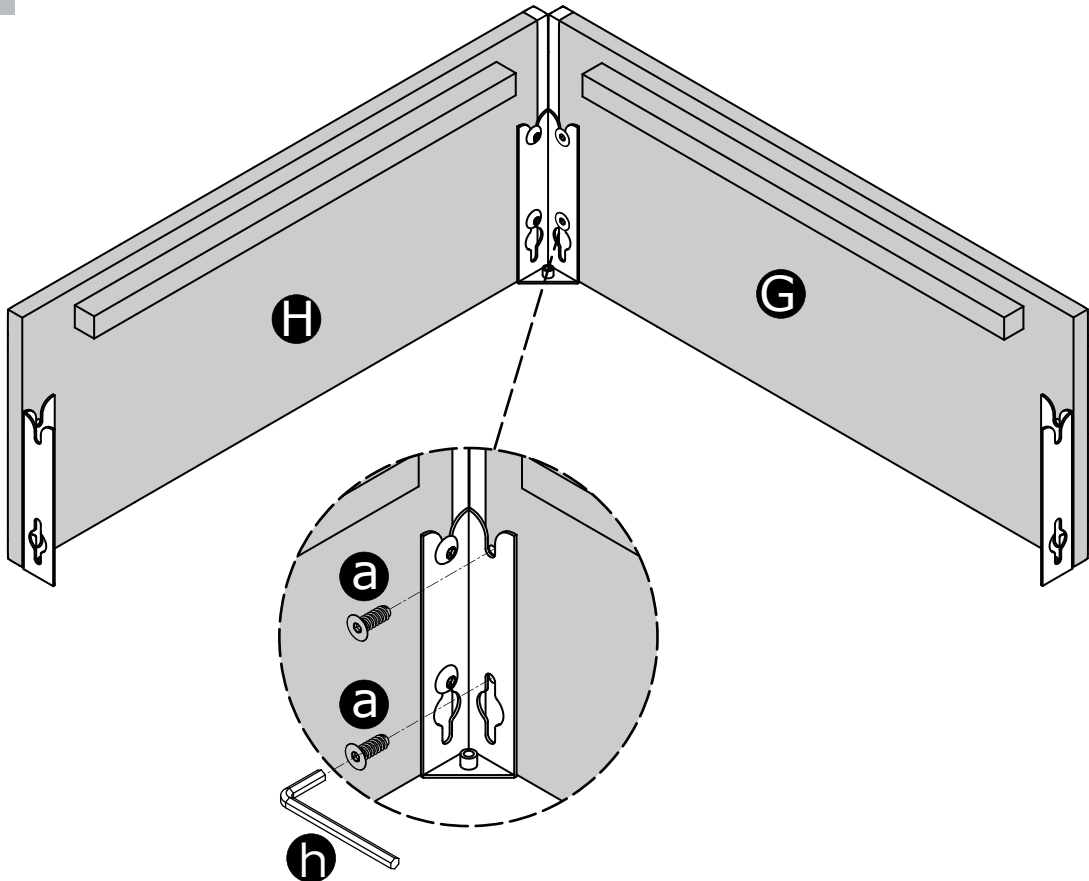

**STEP 3**

- D** x1
- E** x1
- K** x2
- b** x4
- d** x4
- h** x1

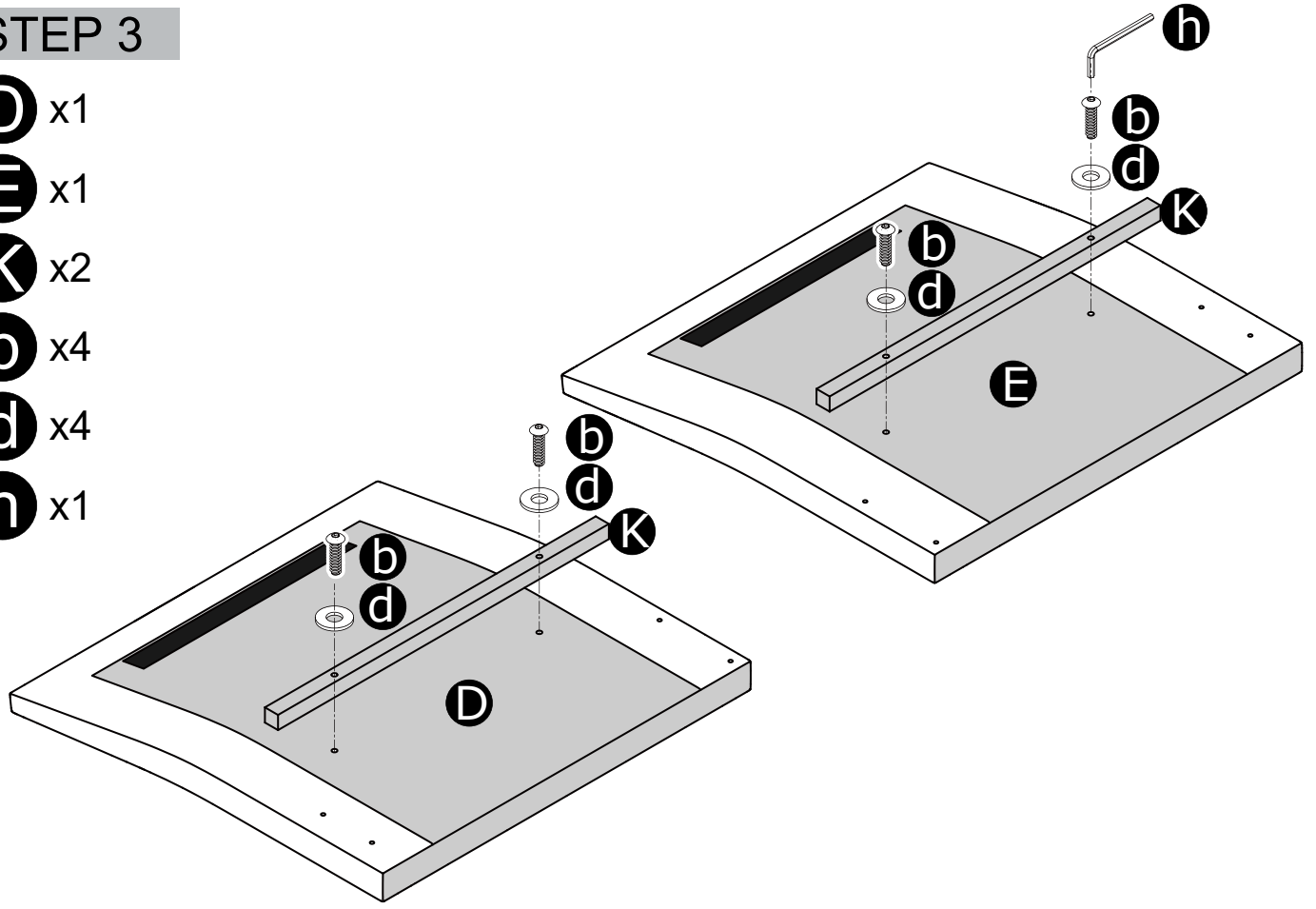

**STEP 4**

- V5** x1
- a** x4
- h** x1

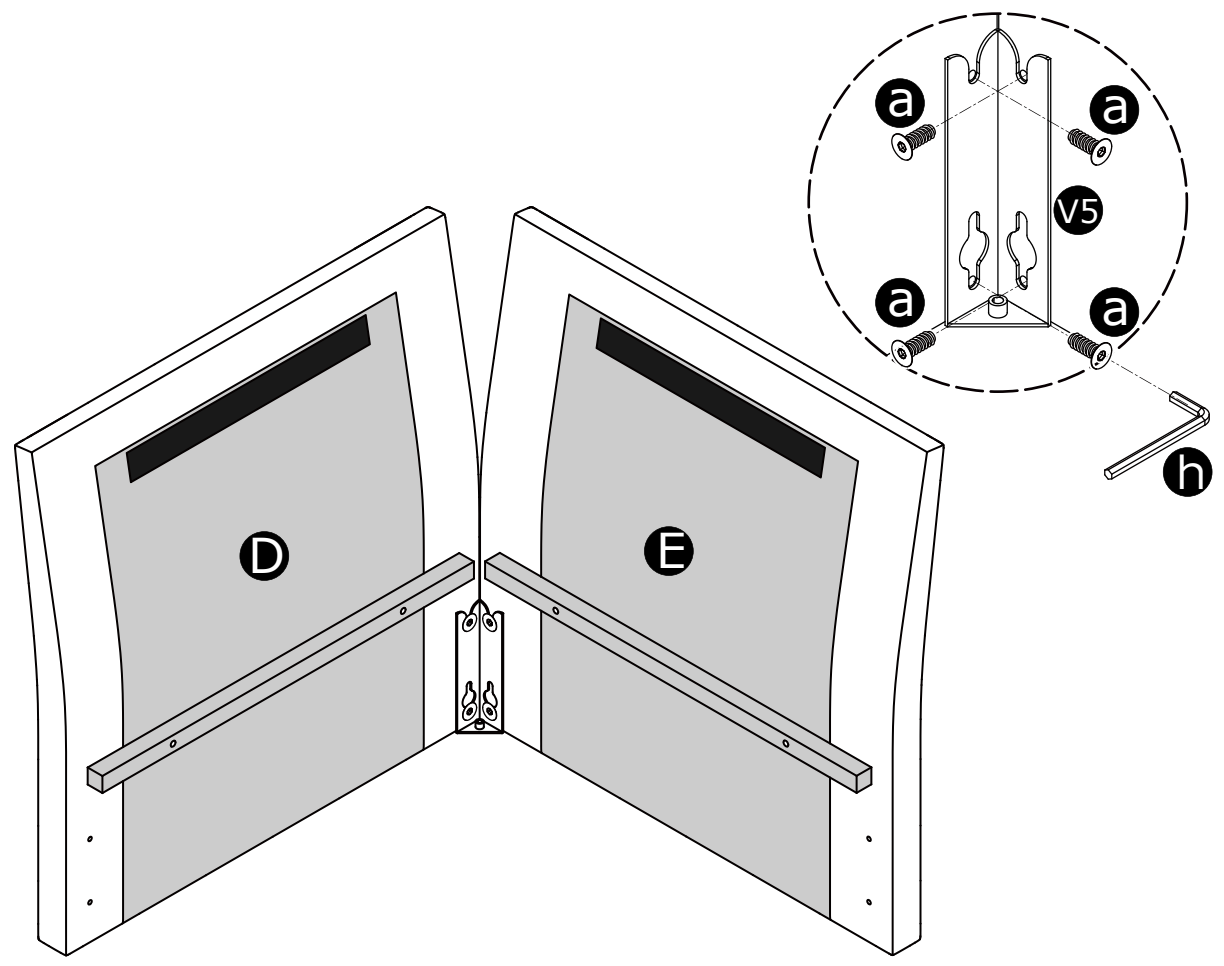

## STEP 5

**a** x4

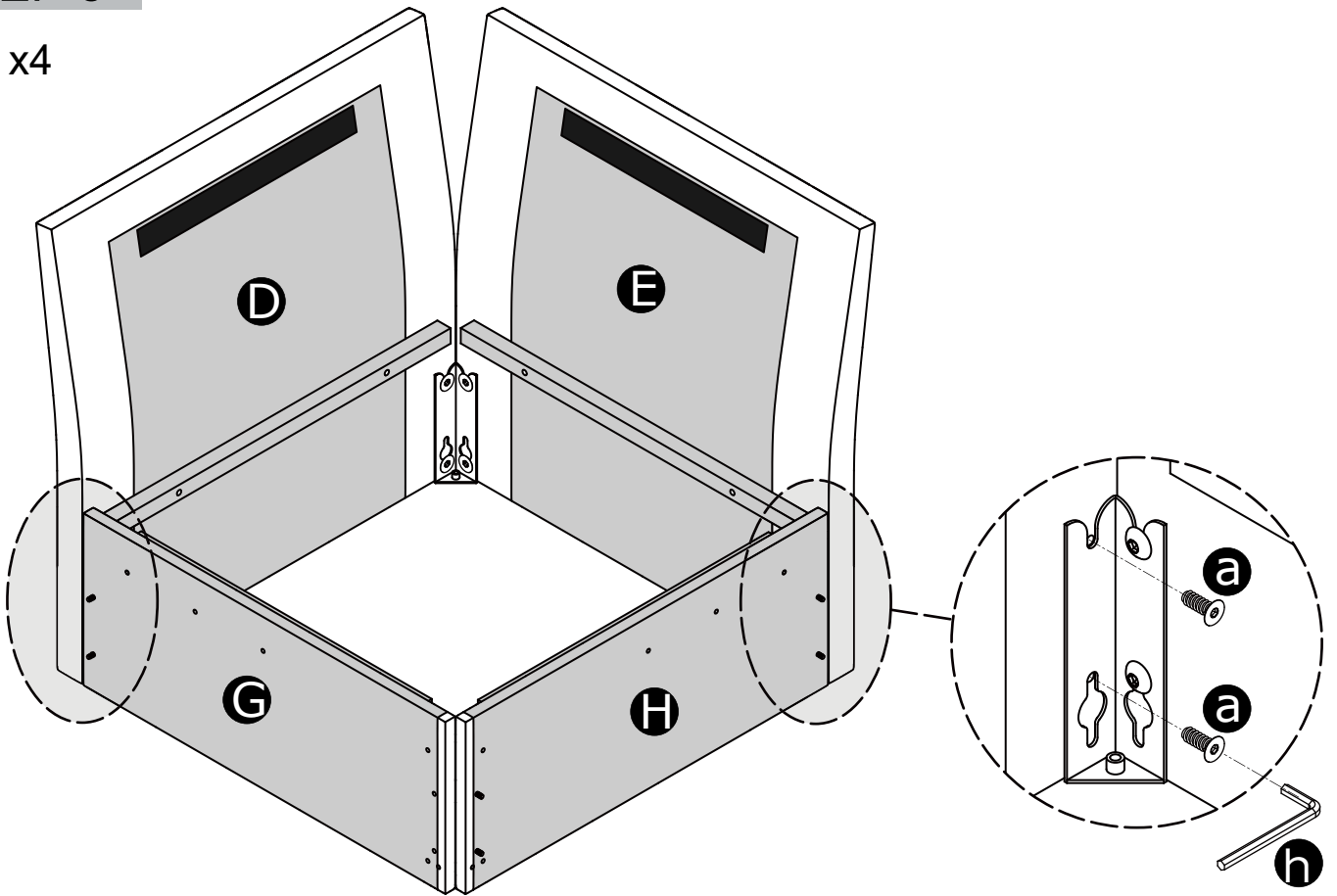

## STEP 6

**V2** x4

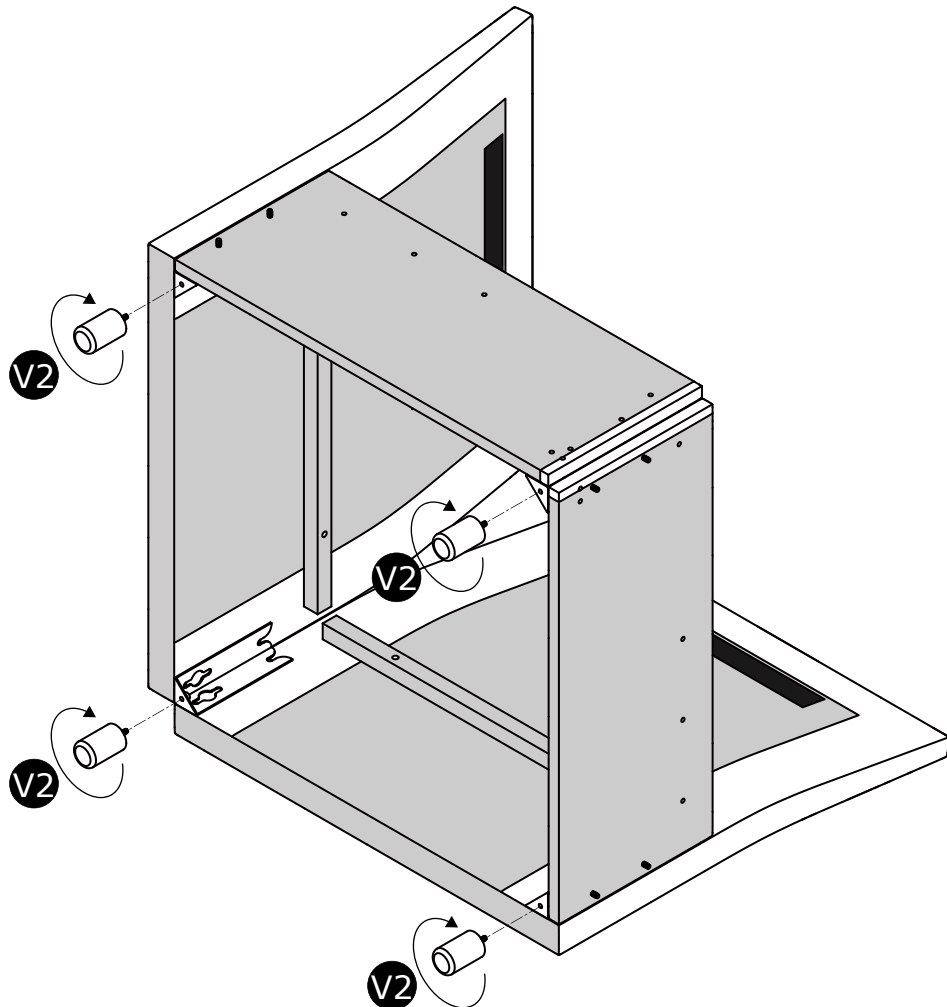

## STEP 7

**C** x1

**S** x1

**V5** x4

**a** x8

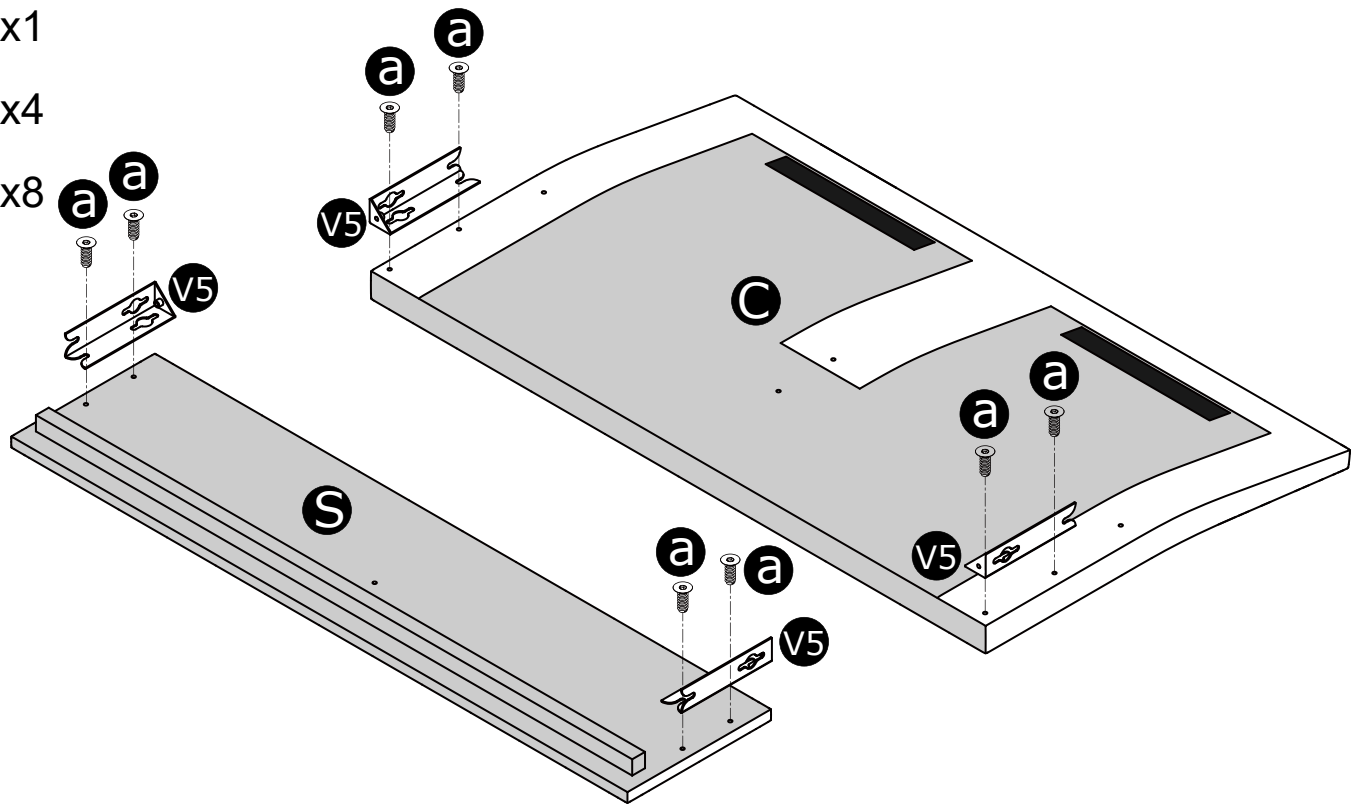

## STEP 8

**B** x1

**V2** x2

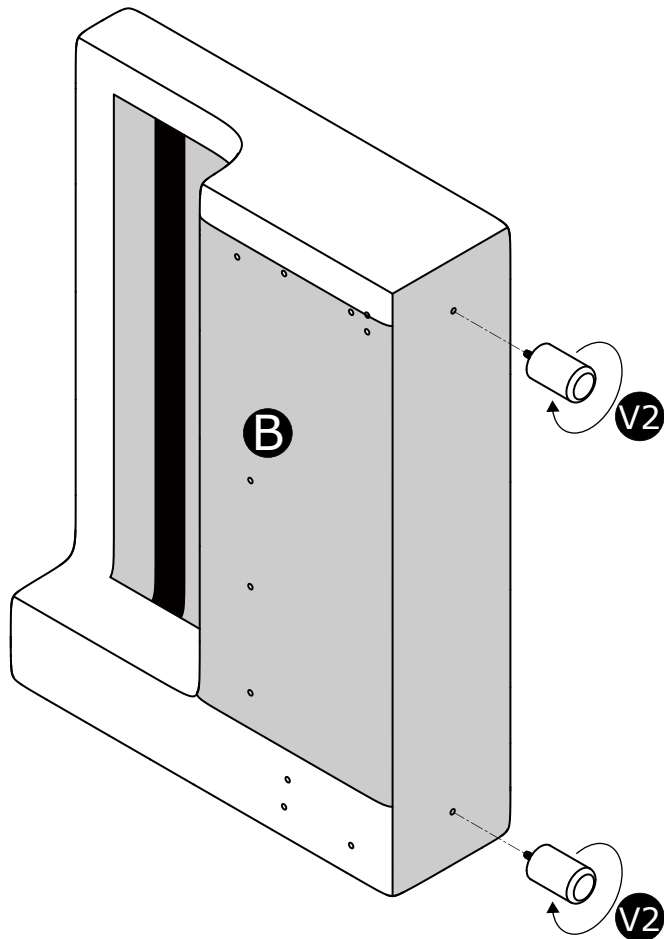

## STEP 9

**a** x4

**h** x1

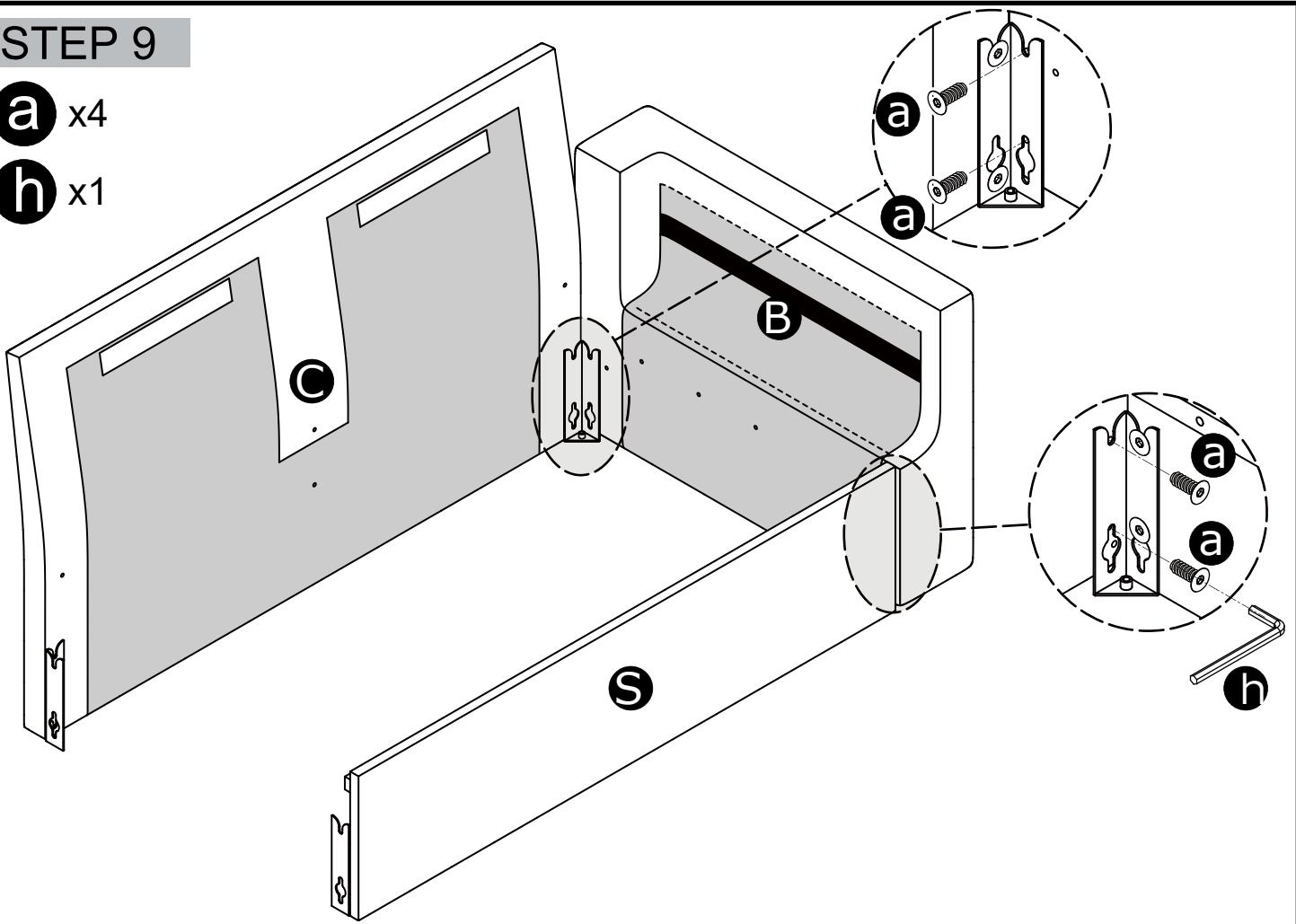

## STEP 10

**c** x4

**d** x4

**f** x1

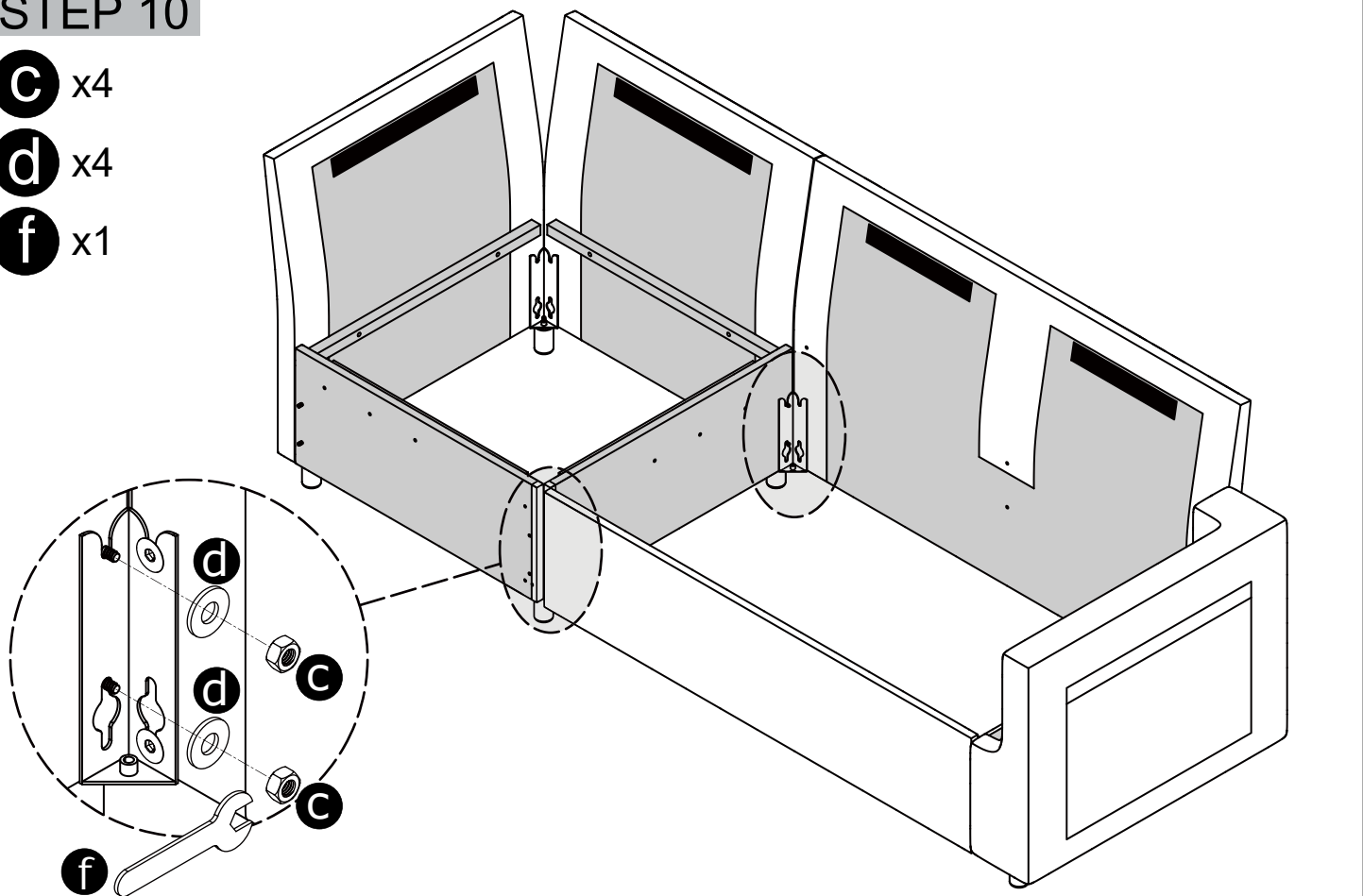

## STEP 11

- F** x1
- a** x4
- d** x4
- V6** x4
- h** x1

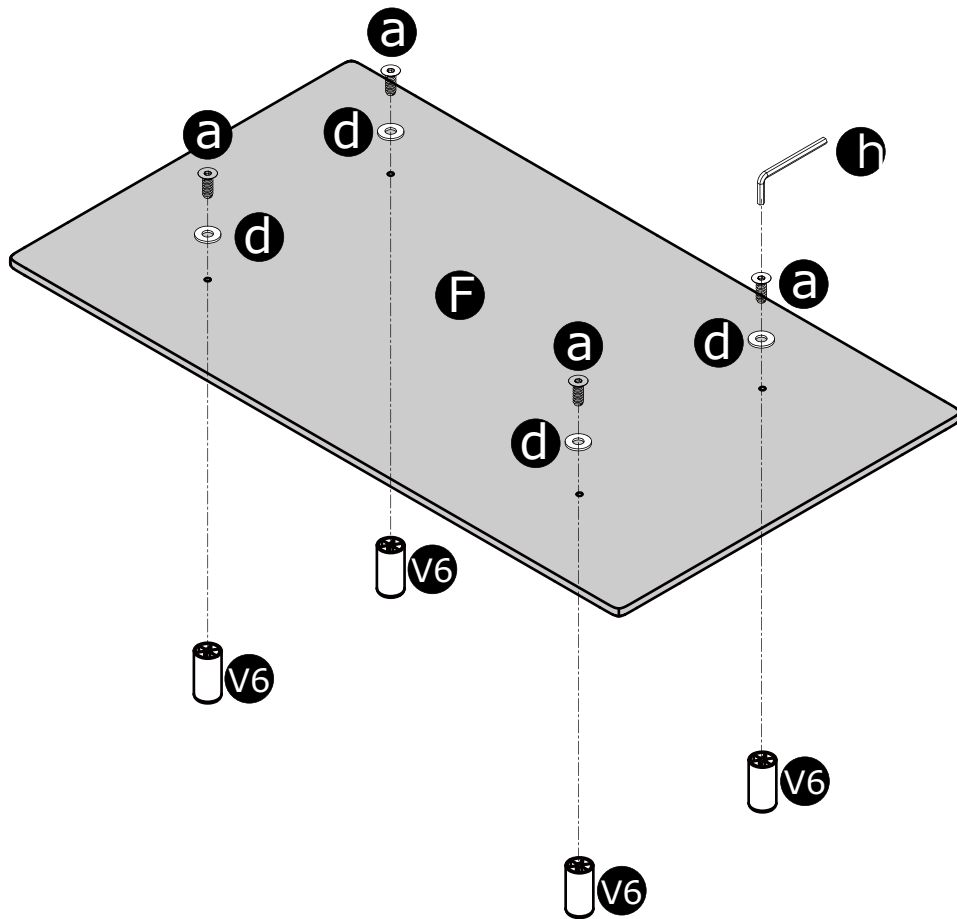

## STEP 12

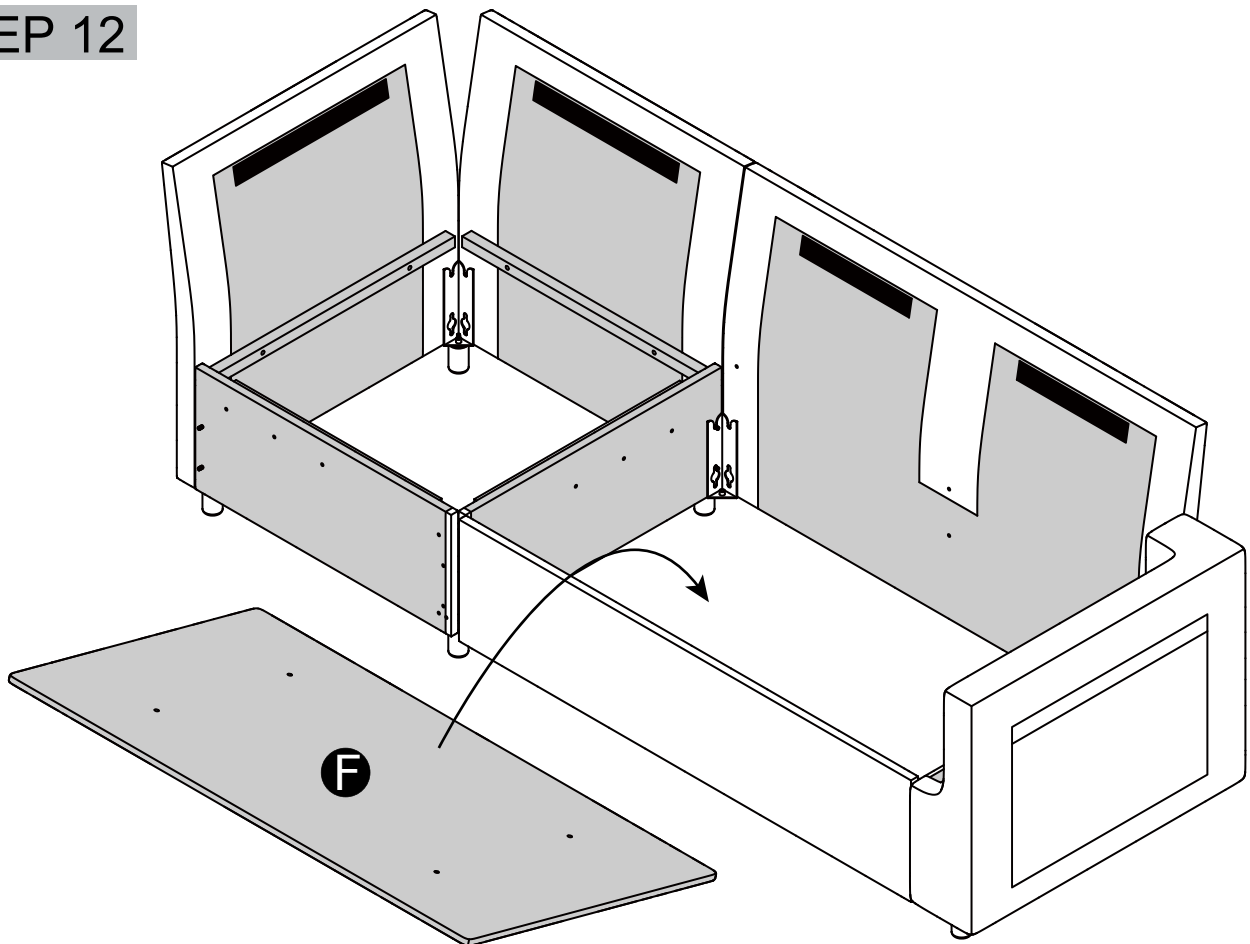

### STEP 13

- a** x2
- b** x2
- c** x1
- L** x1
- v1** x1
- f** x1
- h** x1

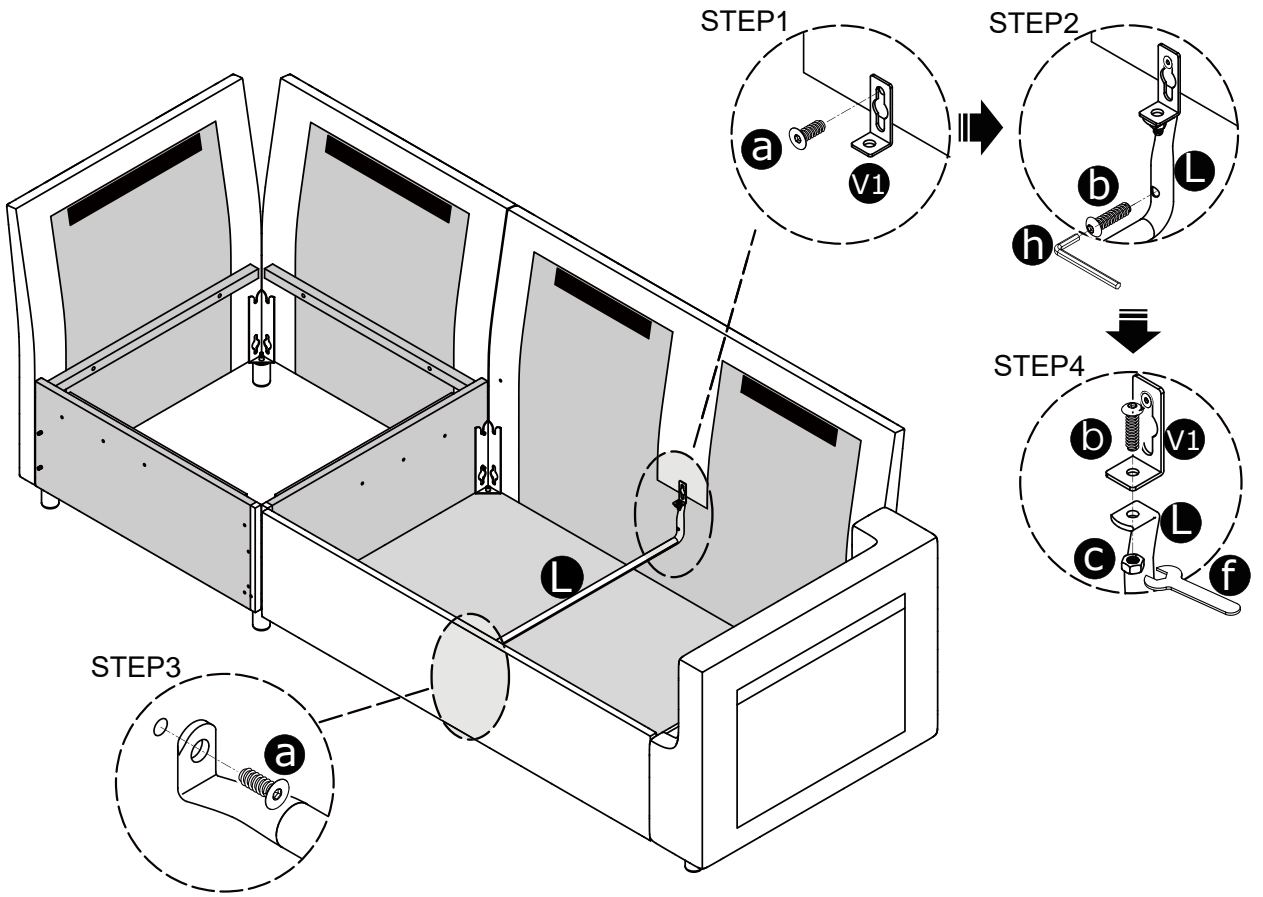

### STEP 14

- T4** x1
- R-L** x1
- R-R** x1
- a** x4
- h** x1

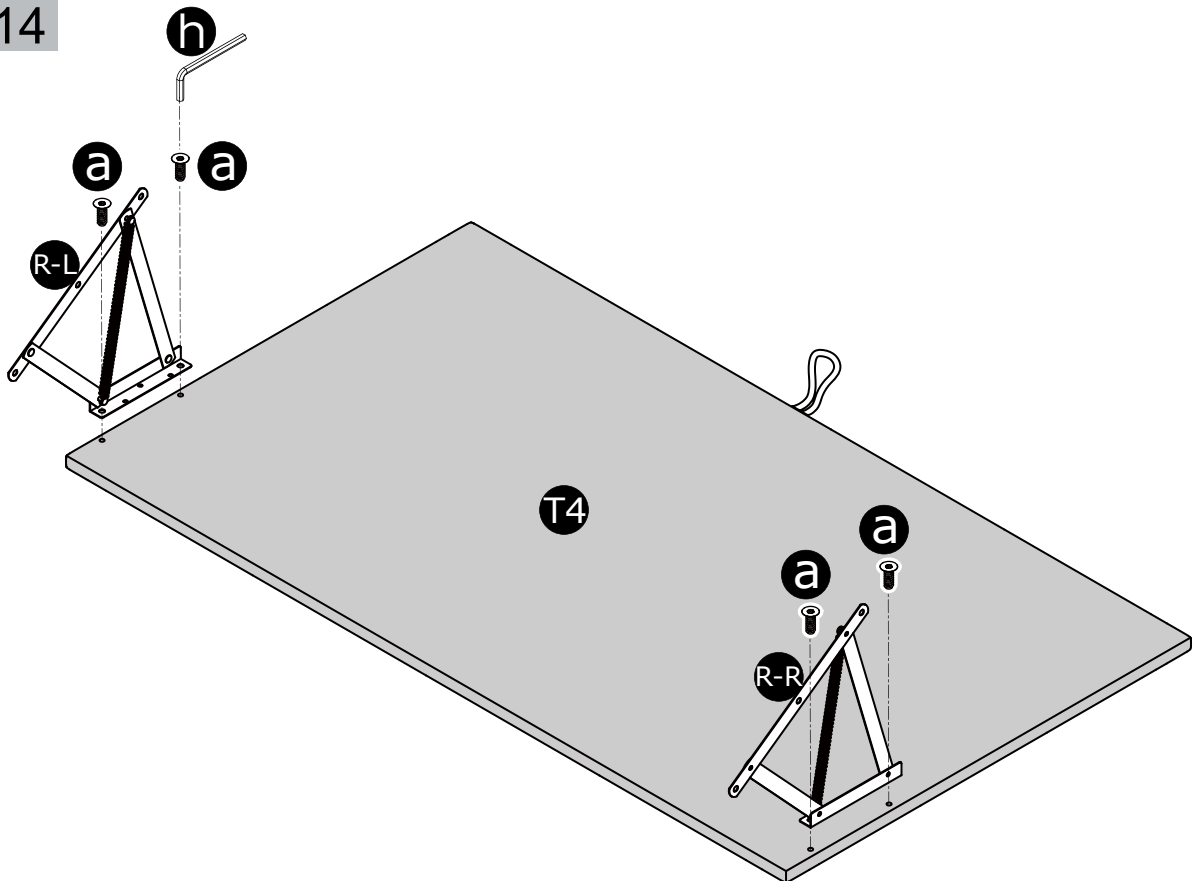

# STEP 15

**a** x6

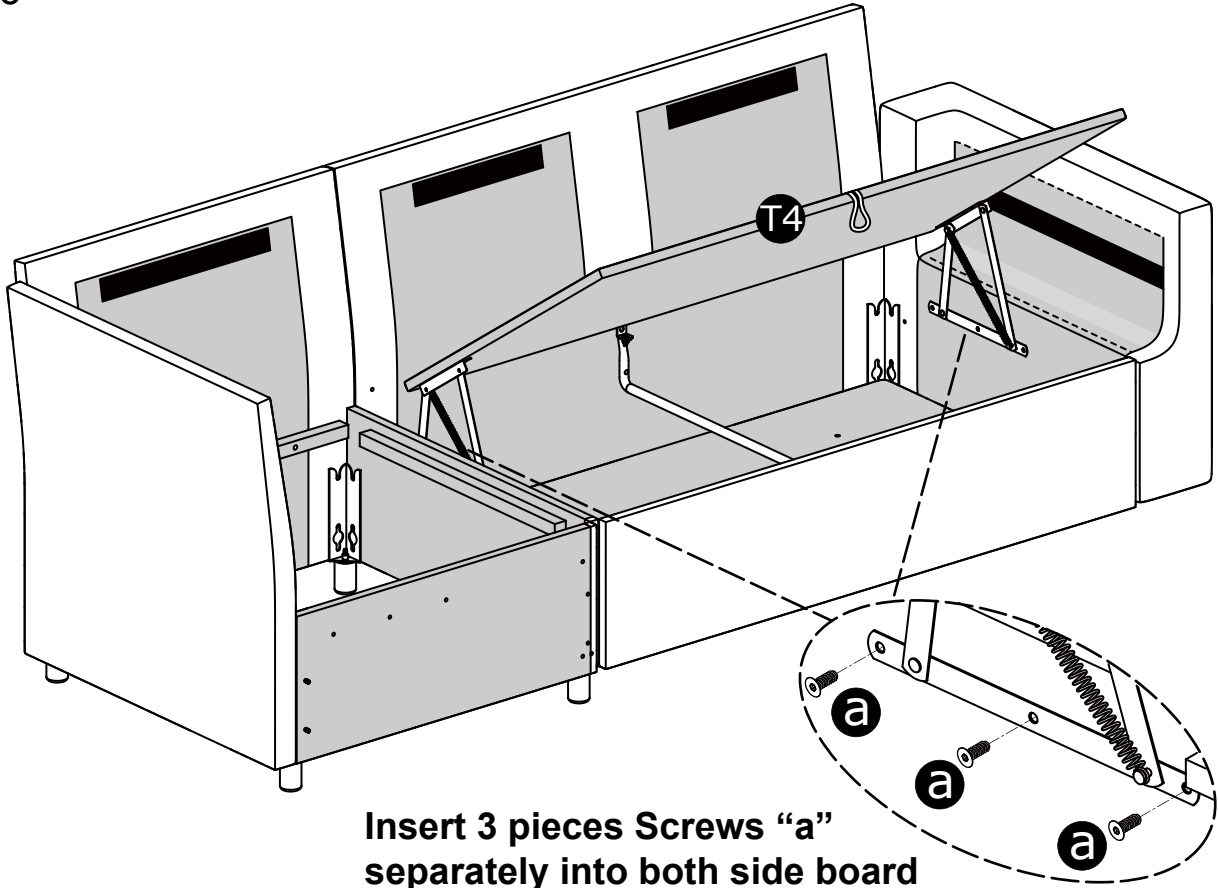

# STEP 16

- V5** x1   **V3** x1
- c** x2   **a** x3
- d** x2   **h** x1
- f** x1   **T1** x1

**!** Insert the screws, but do not tighten them fully at this time.

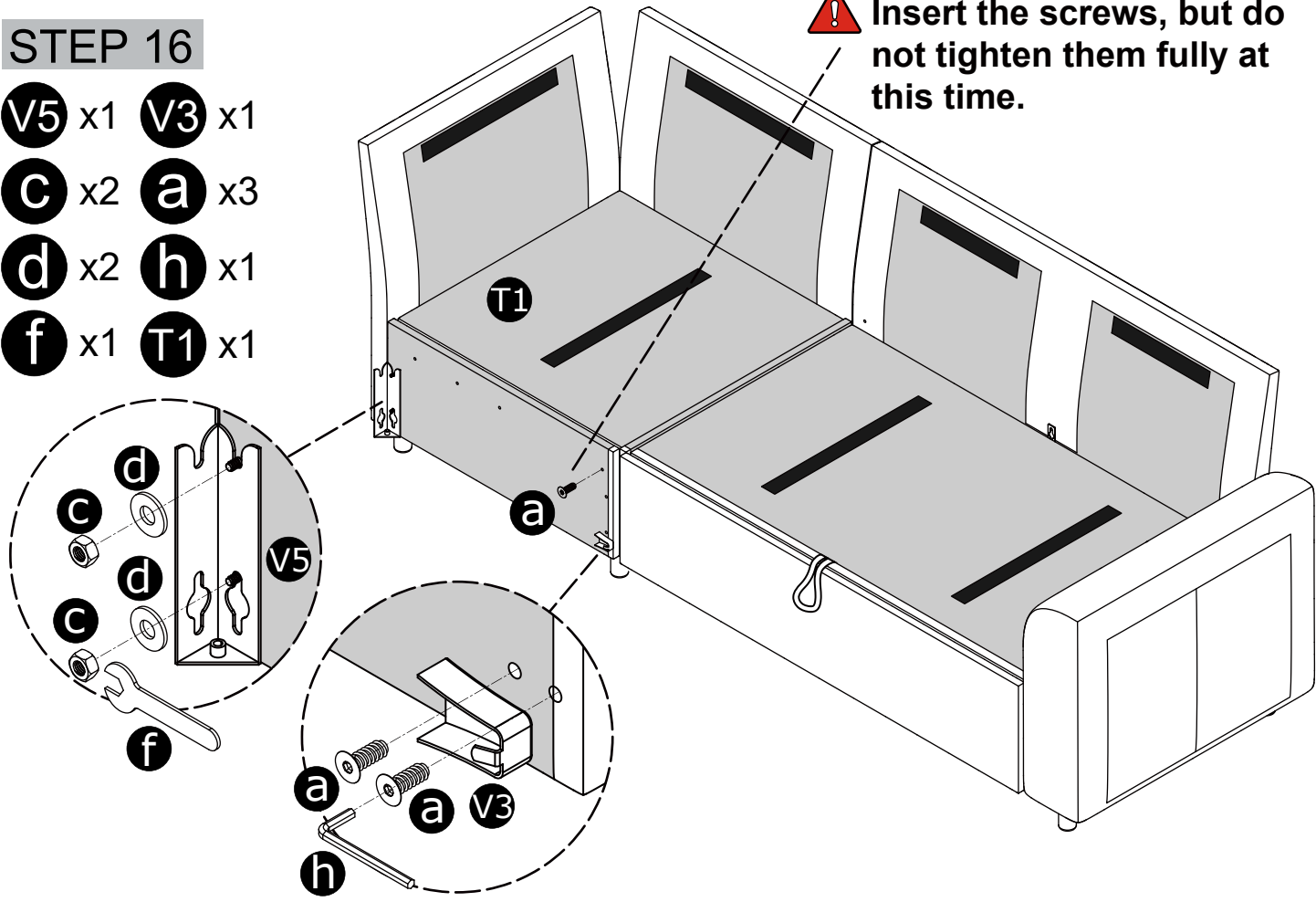

## STEP 17

**N-L** x1

**N-R** x1

**V5** x4

**a** x6

**b** x2

**h** x1

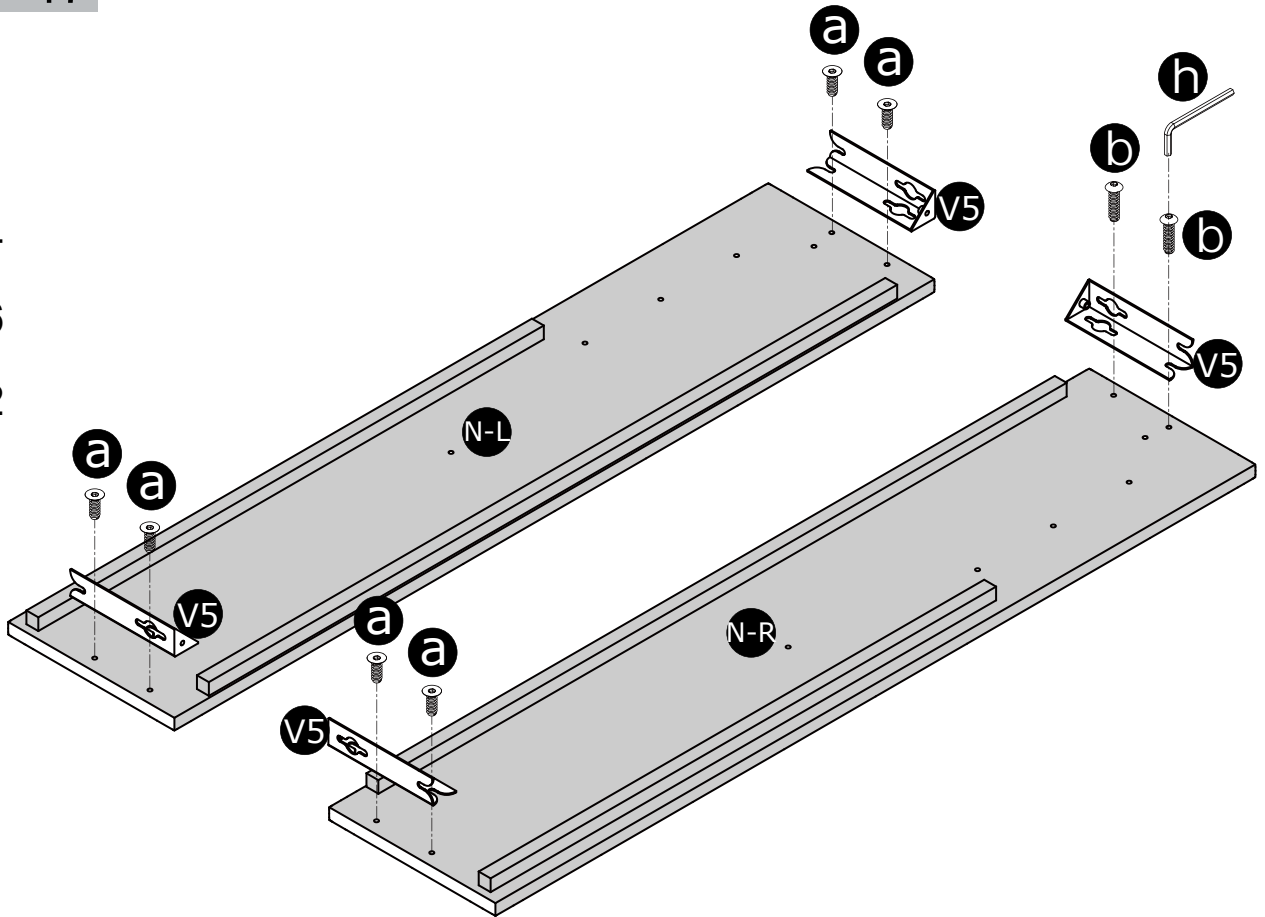

## STEP 18

**A** x1

**b** x2

**d** x2

**h** x1

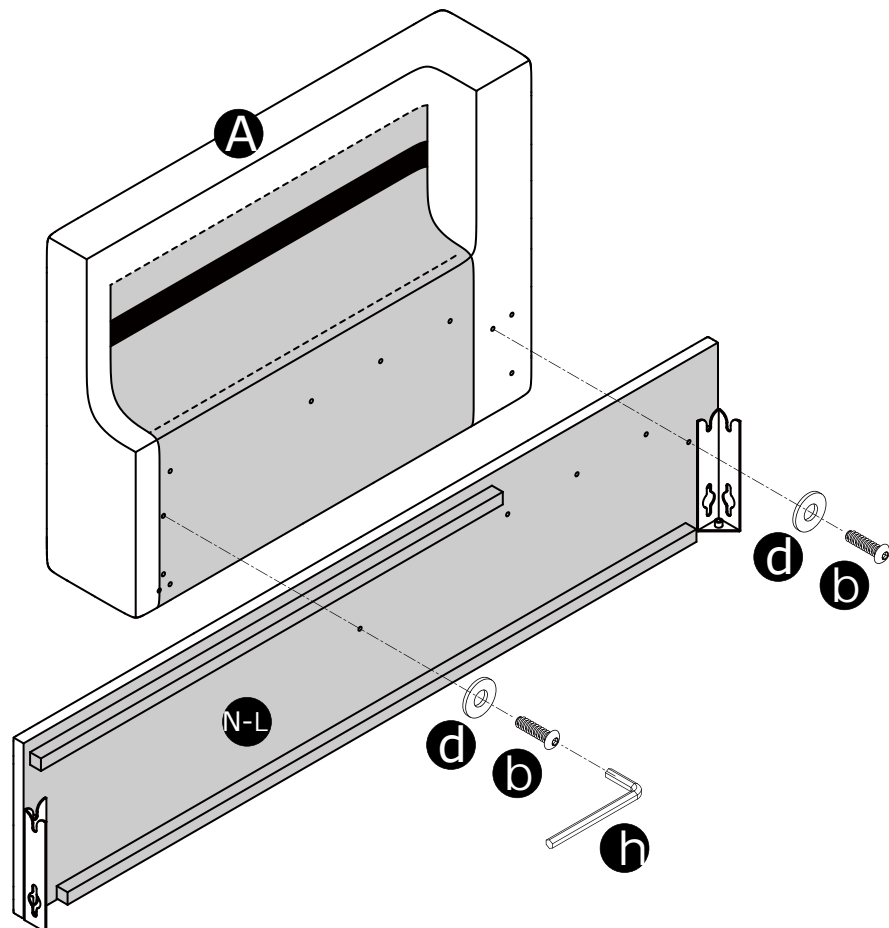

## STEP 19

**M** x1

**P** x1

**a** x8

**h** x1

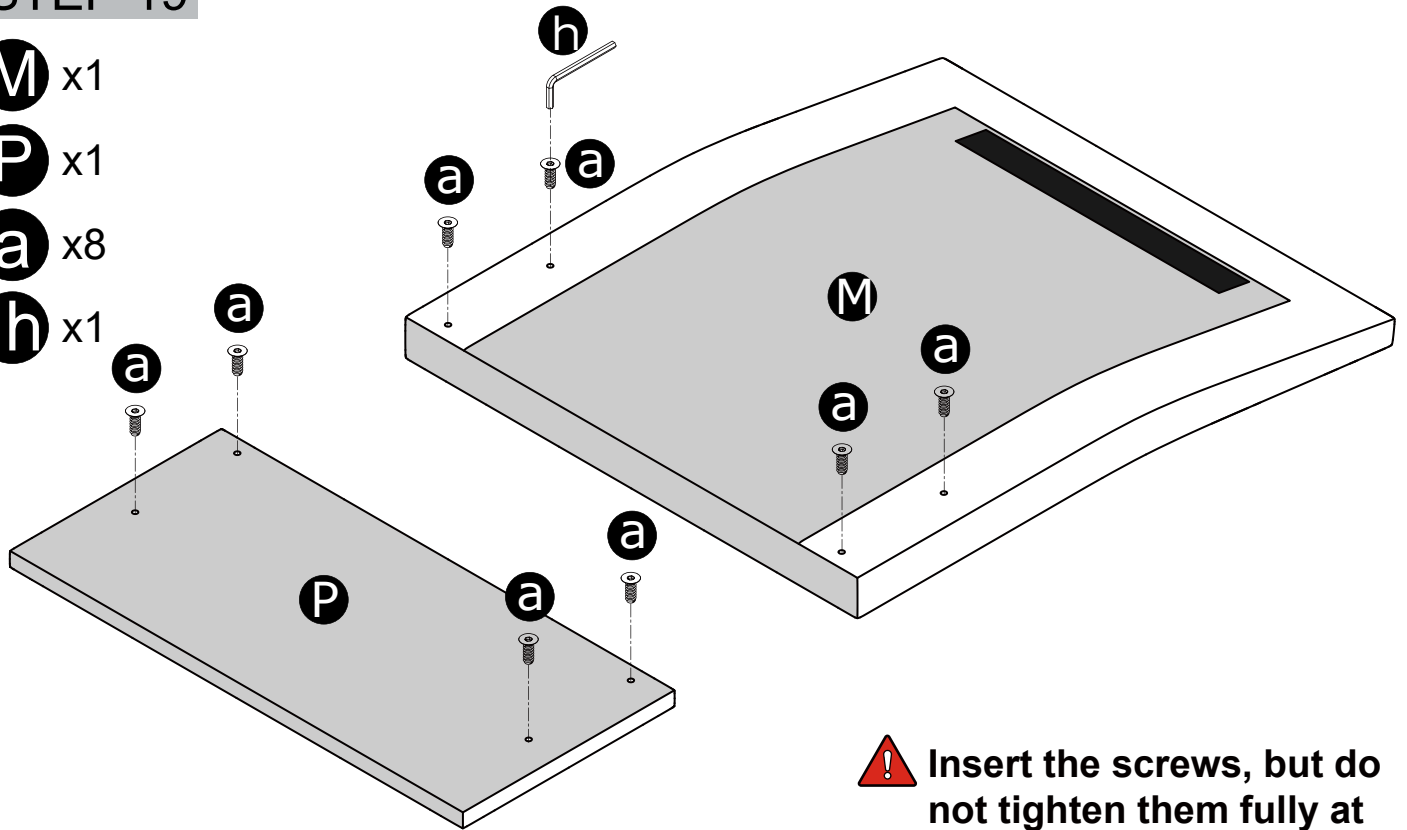

**!** Insert the screws, but do not tighten them fully at this time.

## STEP 20

**!** Slide the screws "a" into part "P" and tighten them at this time

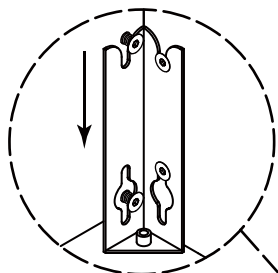

STEP1:SLIDE

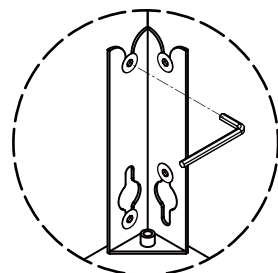

STEP2:TIGHTEN

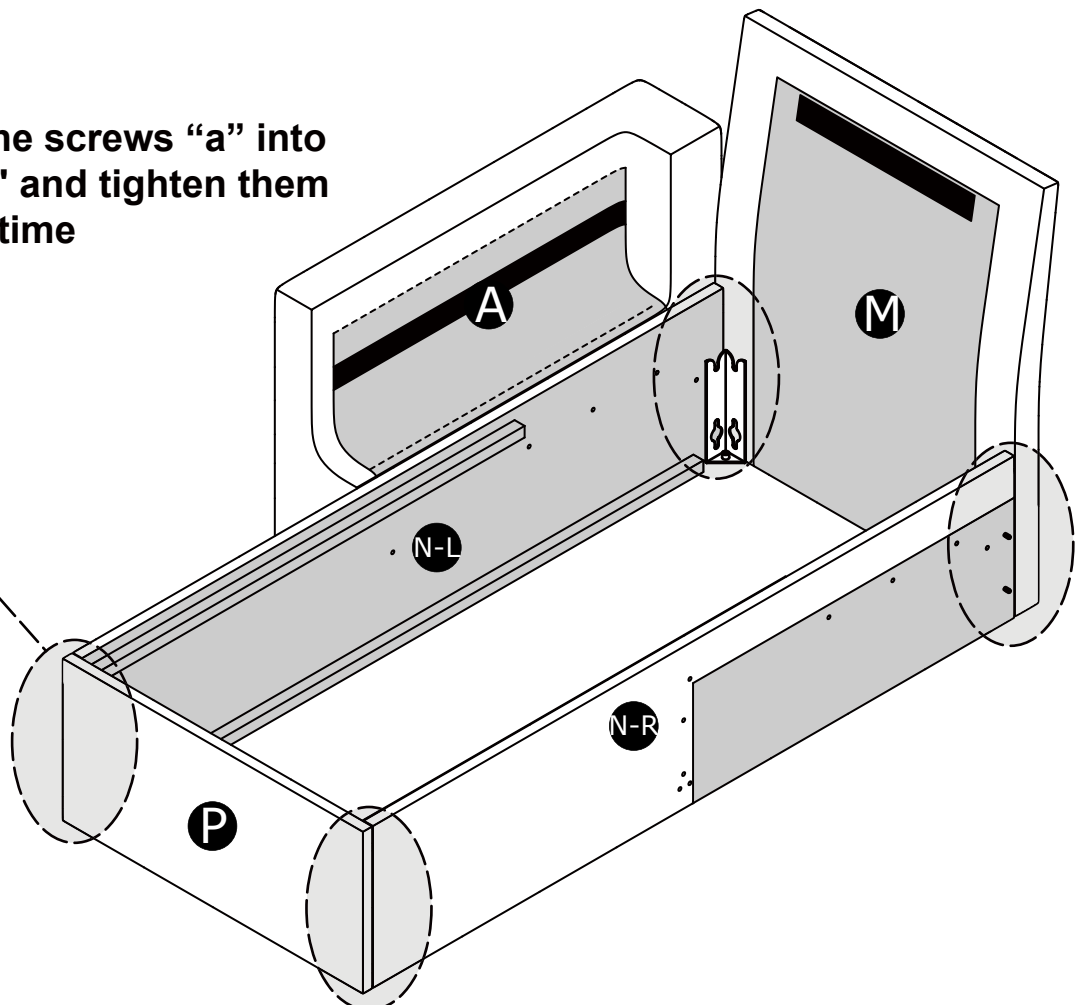

## STEP 21

**V2** x4

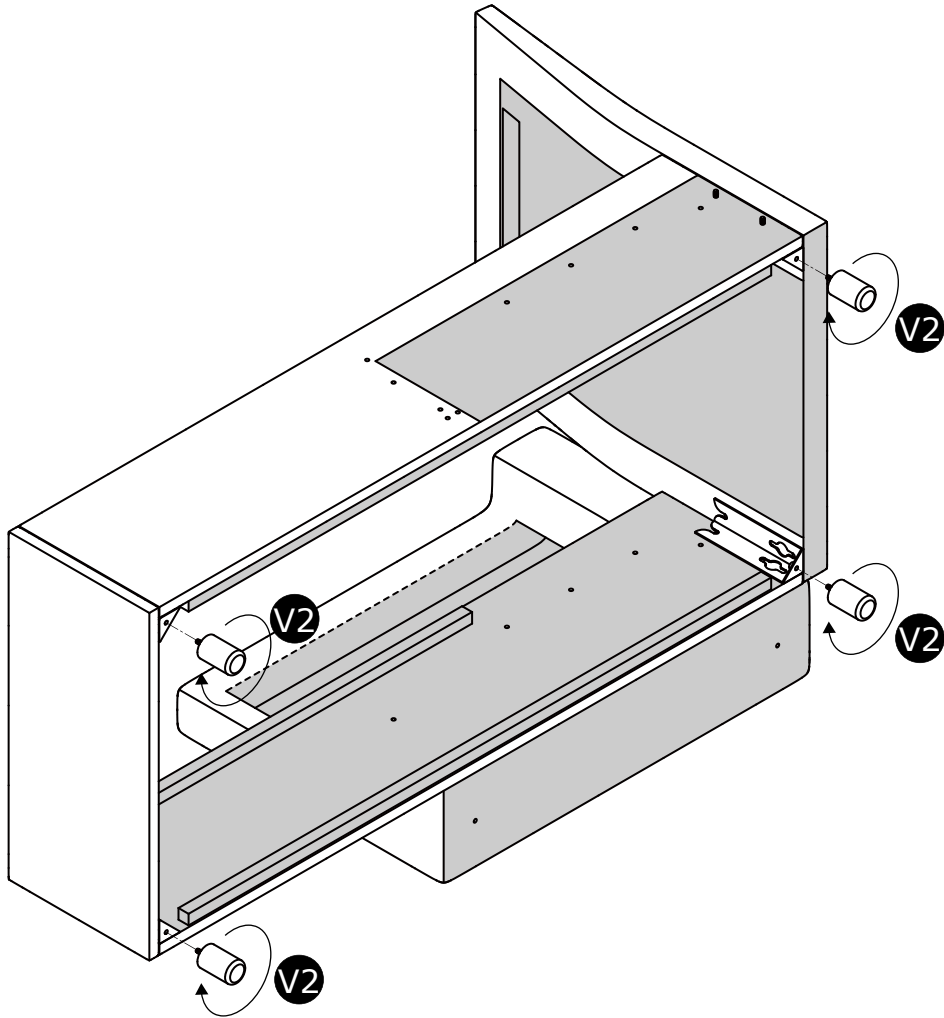

## STEP 22

**Q** x1

**a** x2

**d** x2

**V6** x2

**h** x1

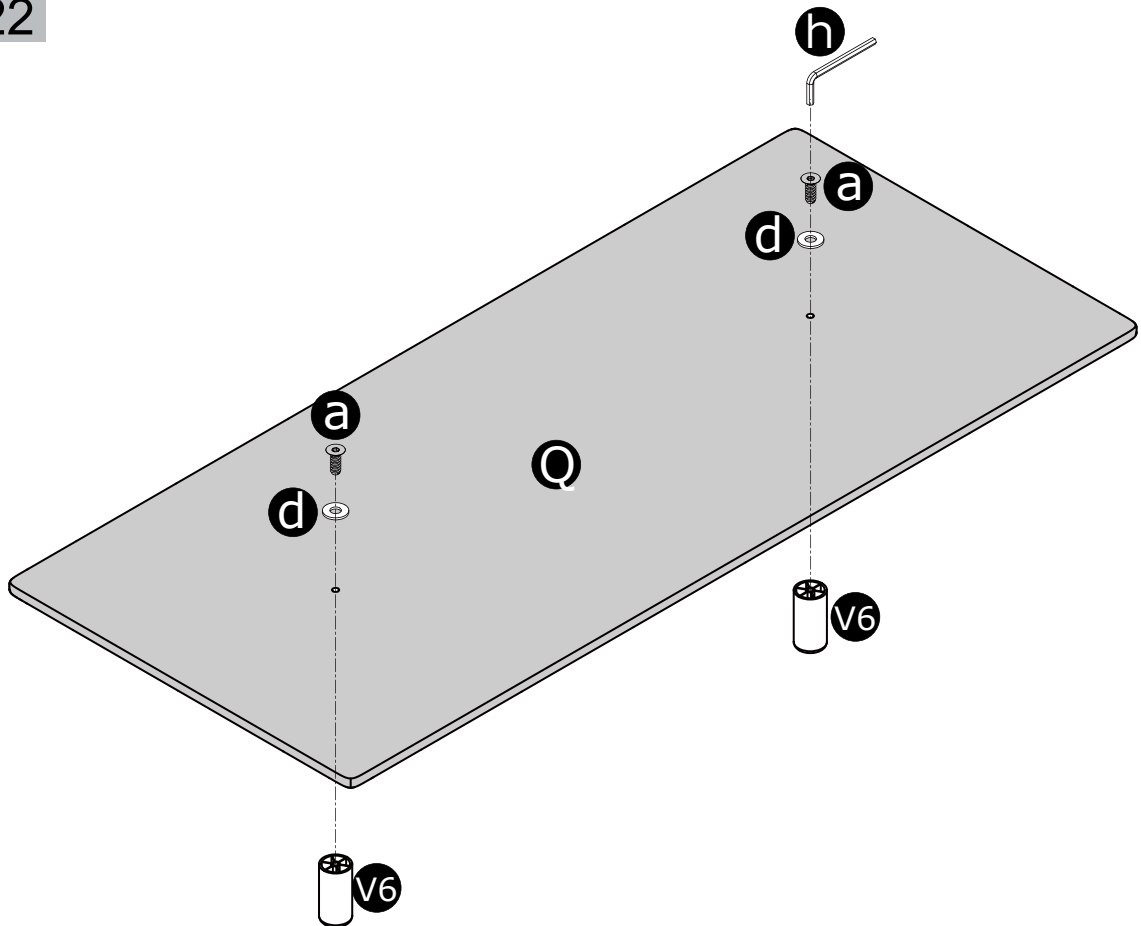

## STEP 23

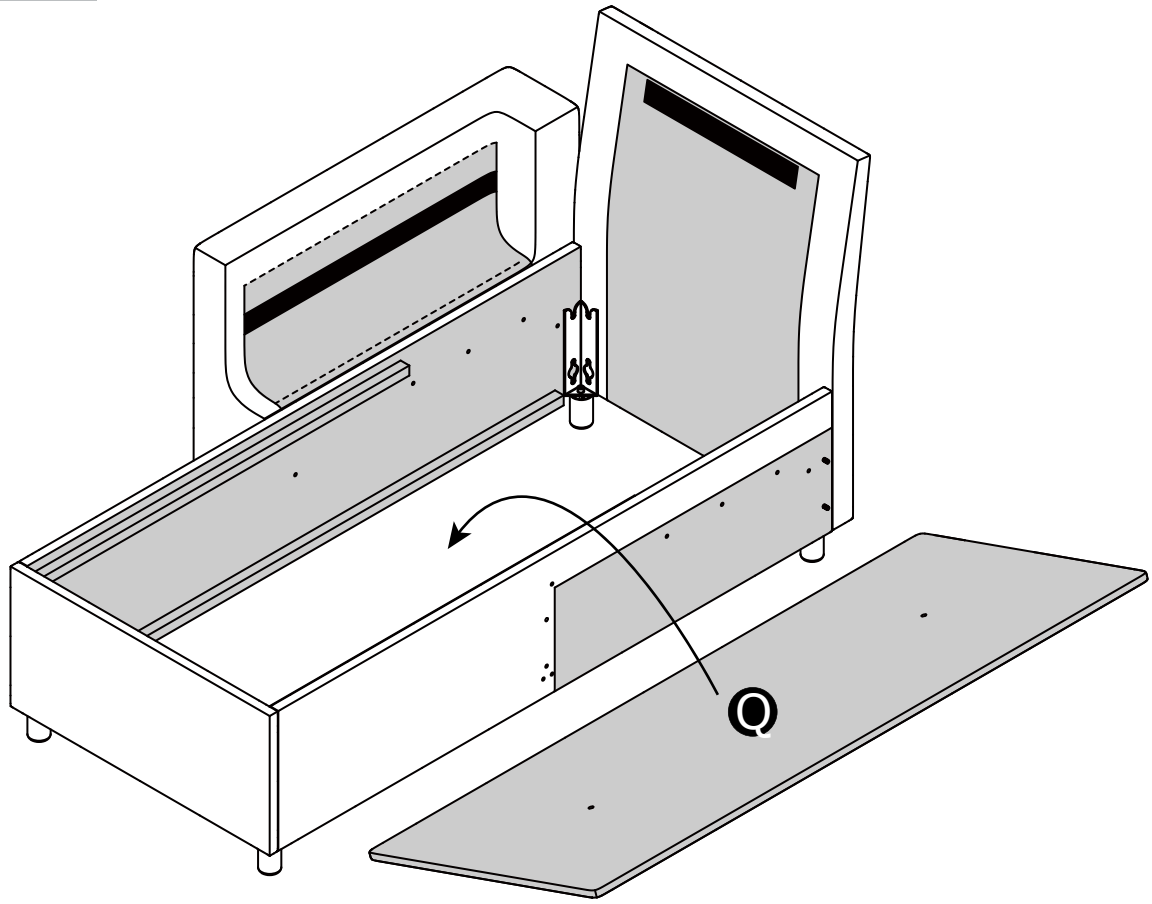

## STEP 24

**T5** x1

**R-L** x1

**R-R** x1

**a** x4

**h** x1

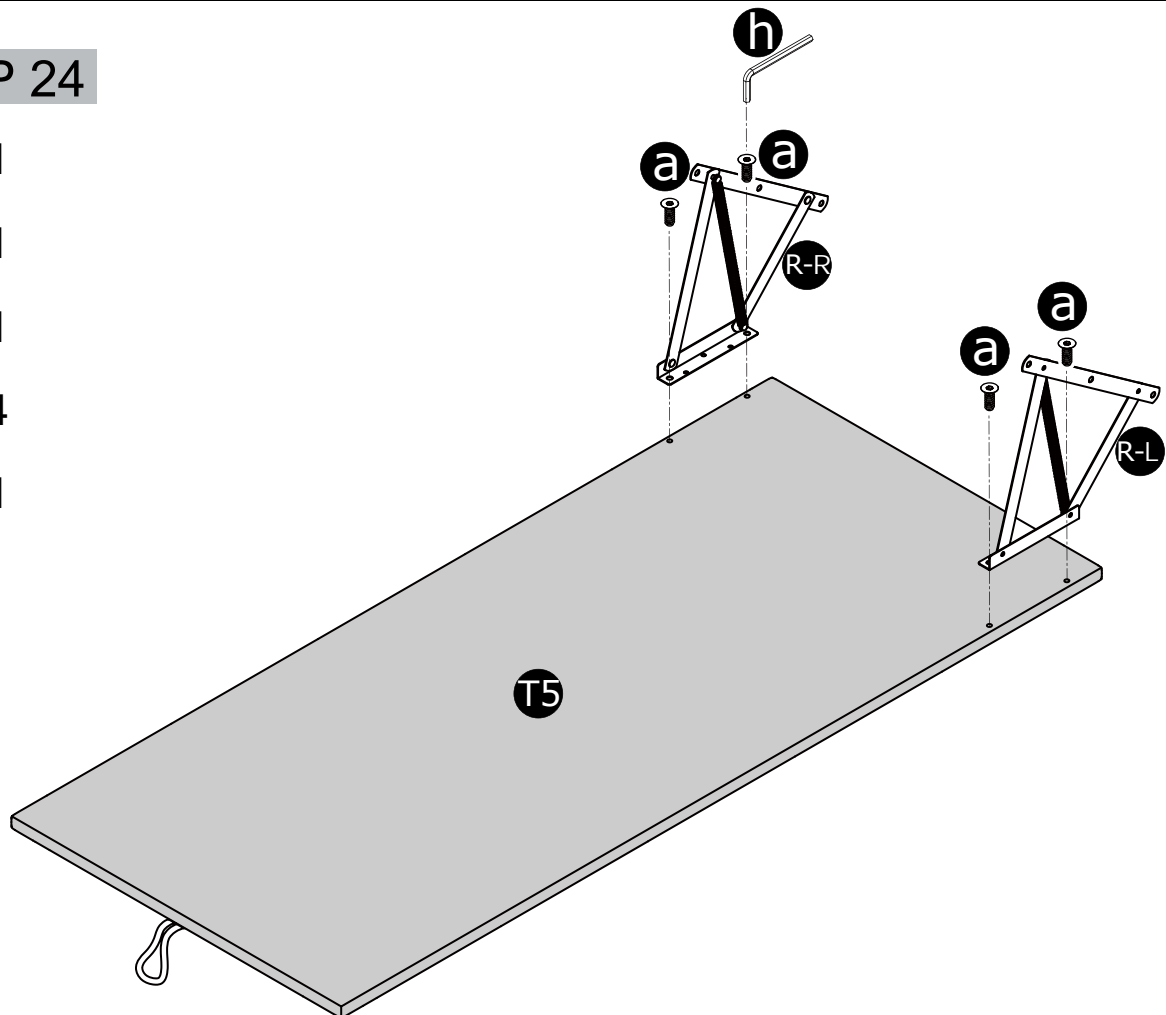

## STEP 25

**a** x6

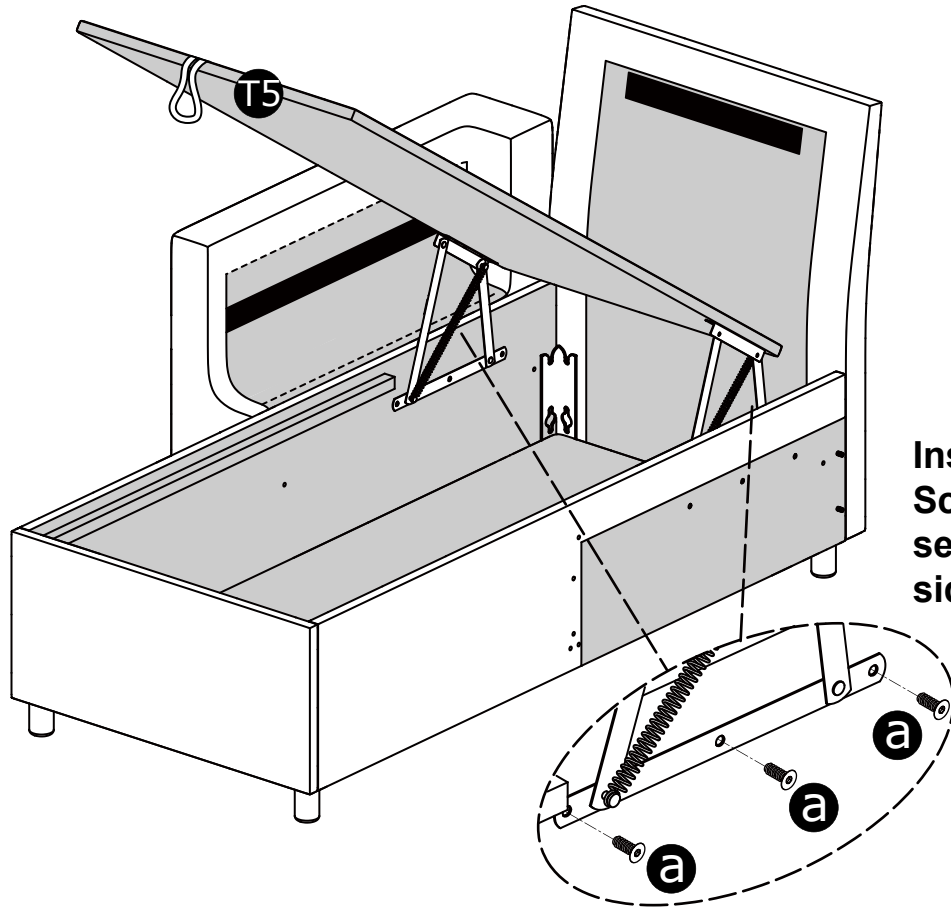

Insert 3 pieces  
Screws "a"  
separately into both  
side board

## STEP 26

**V5** x1 **V3** x1  
**C** x2 **a** x3  
**d** x2 **f** x1  
**h** x1

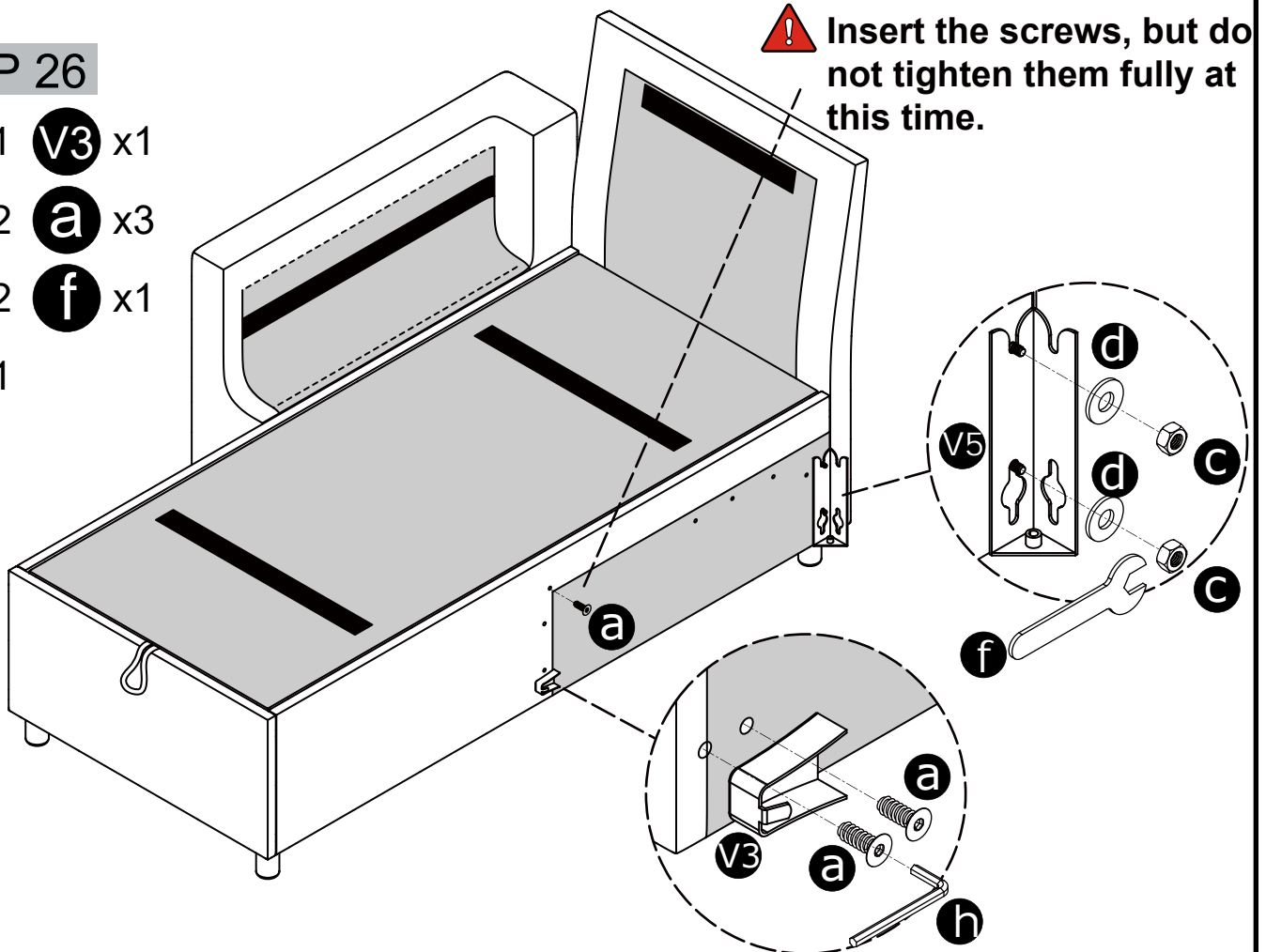

**!** Insert the screws, but do  
not tighten them fully at  
this time.

## STEP 27

**a** x7

**h** x1

**!** Insert the screws, but do not tighten them fully at this time.

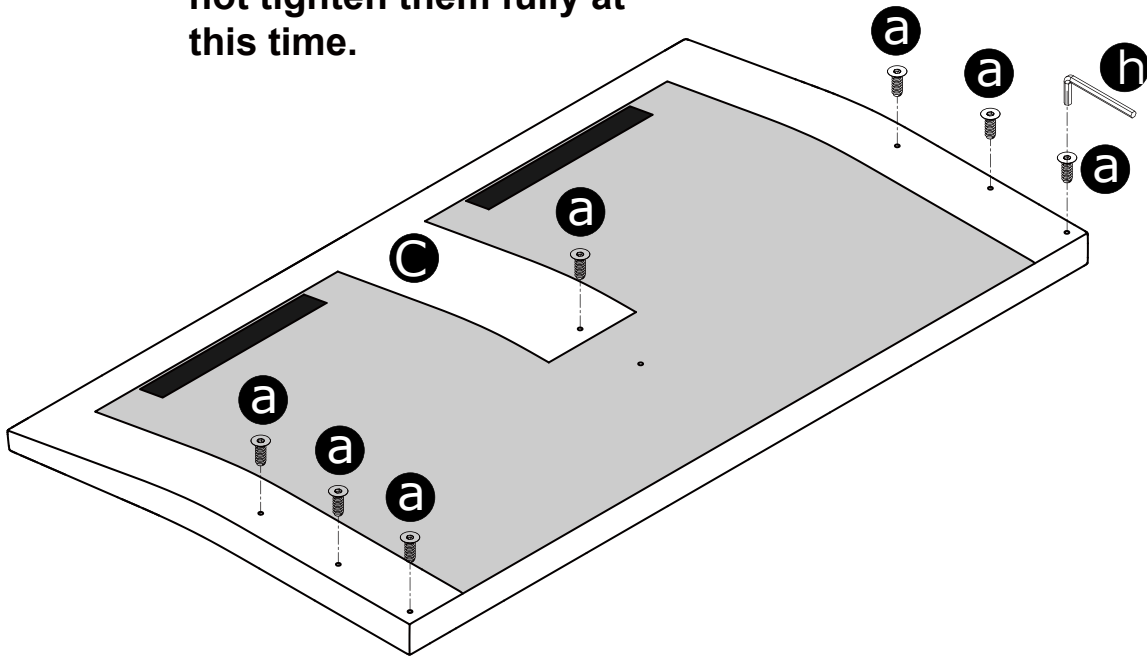

## STEP 28

**!** Slide the screws "a" into part "P" and tighten them at this time

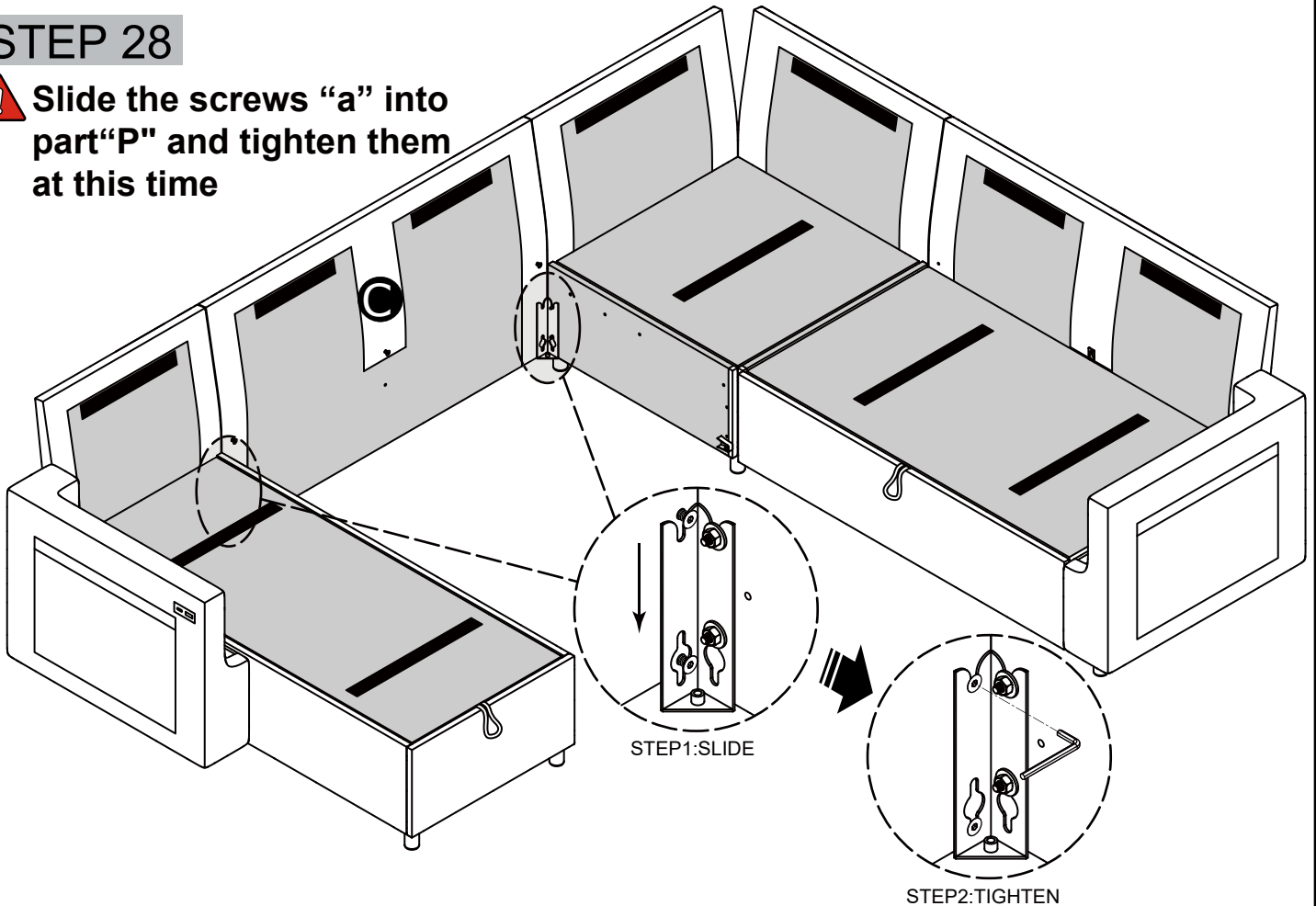

# STEP 29

**a** x5

**h** x1

**V1** x5

**T2** x1

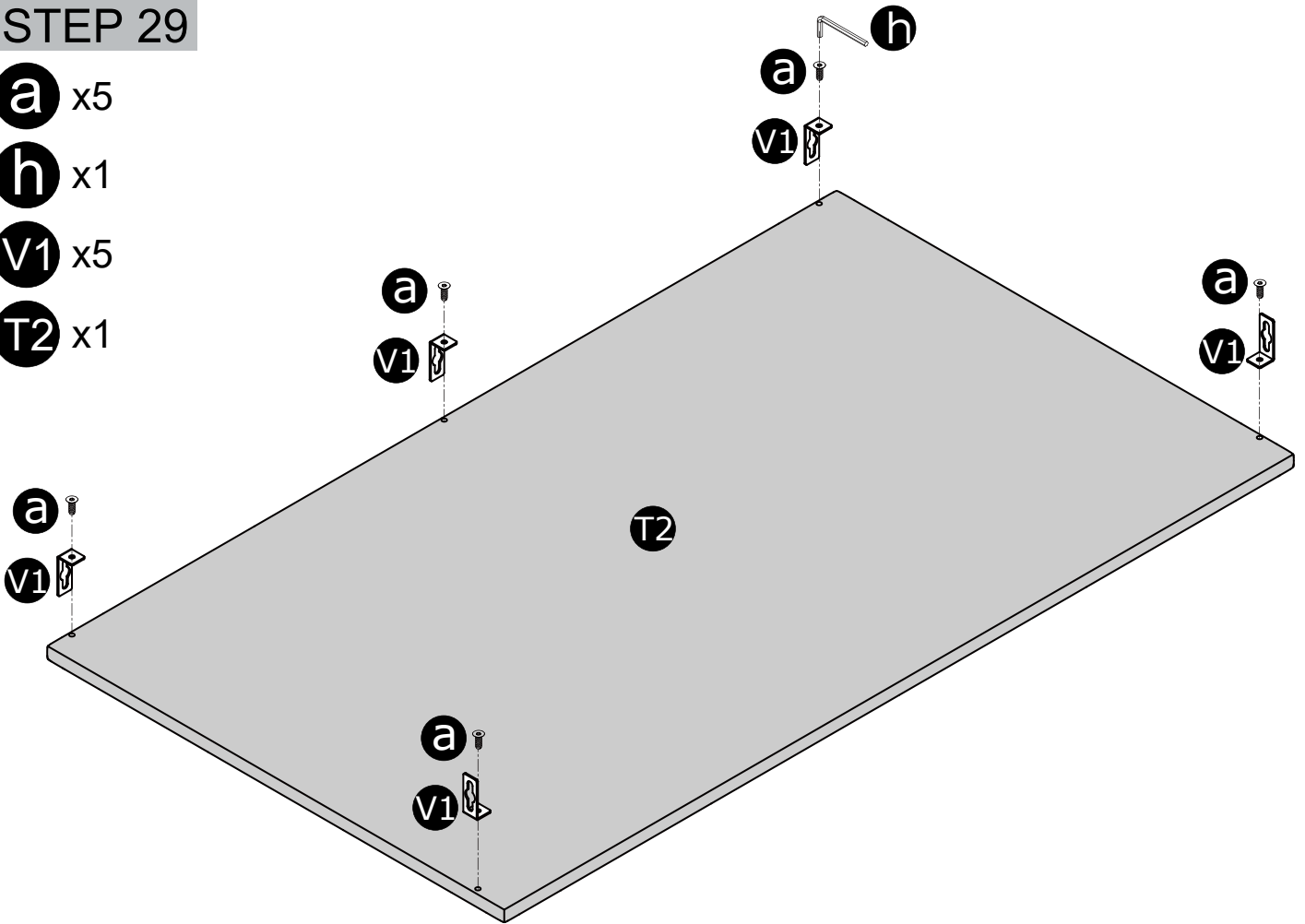

# STEP 30

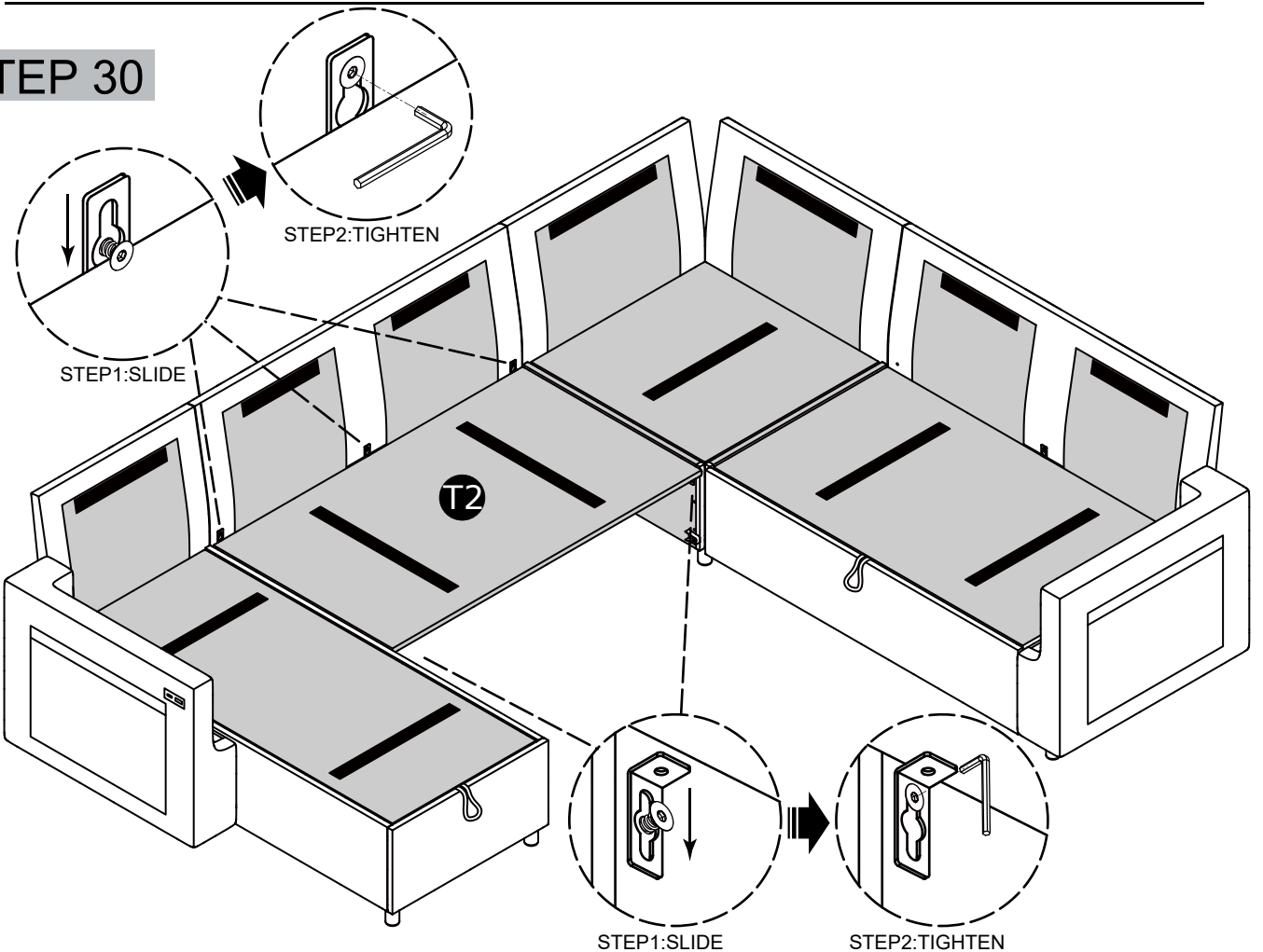

### STEP 31

**e** x4

**Y** x1

**Z** x1

**V4** x2

**g** x1

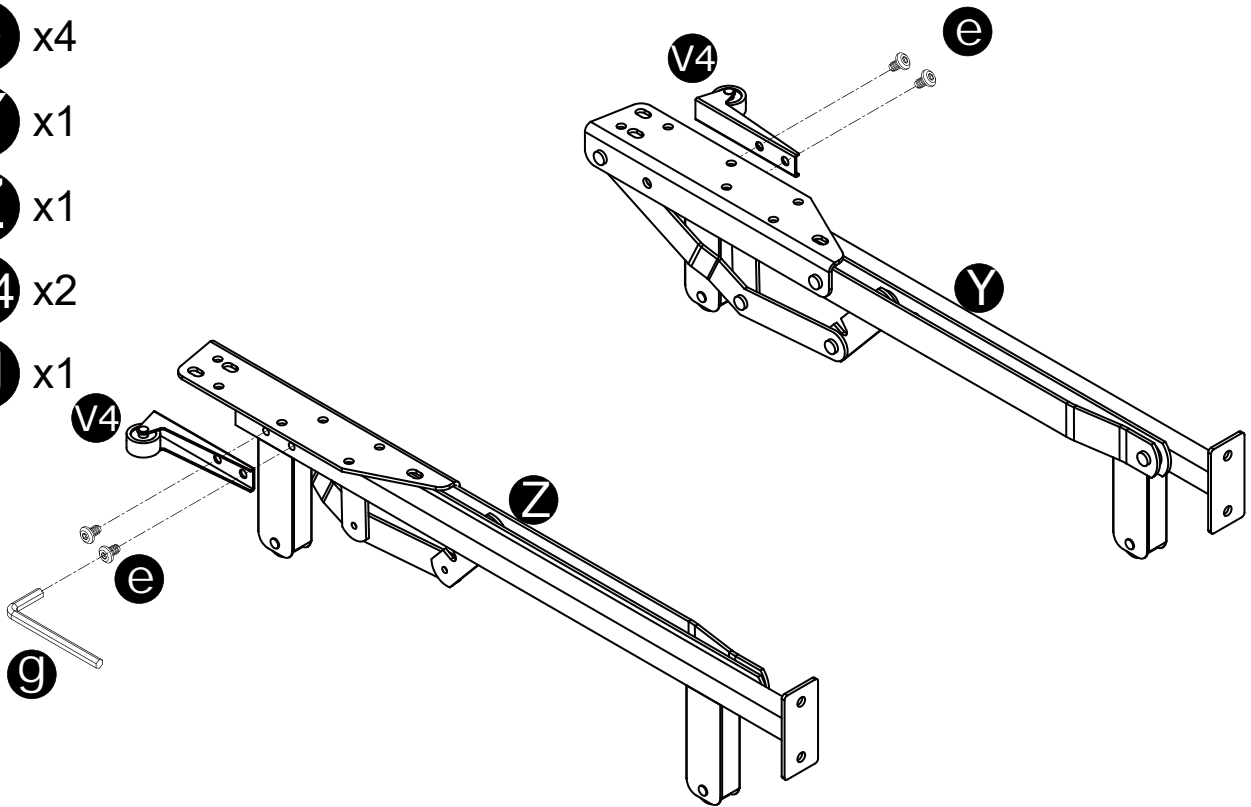

### STEP 32

**a** x4

**J** x1

**d** x2

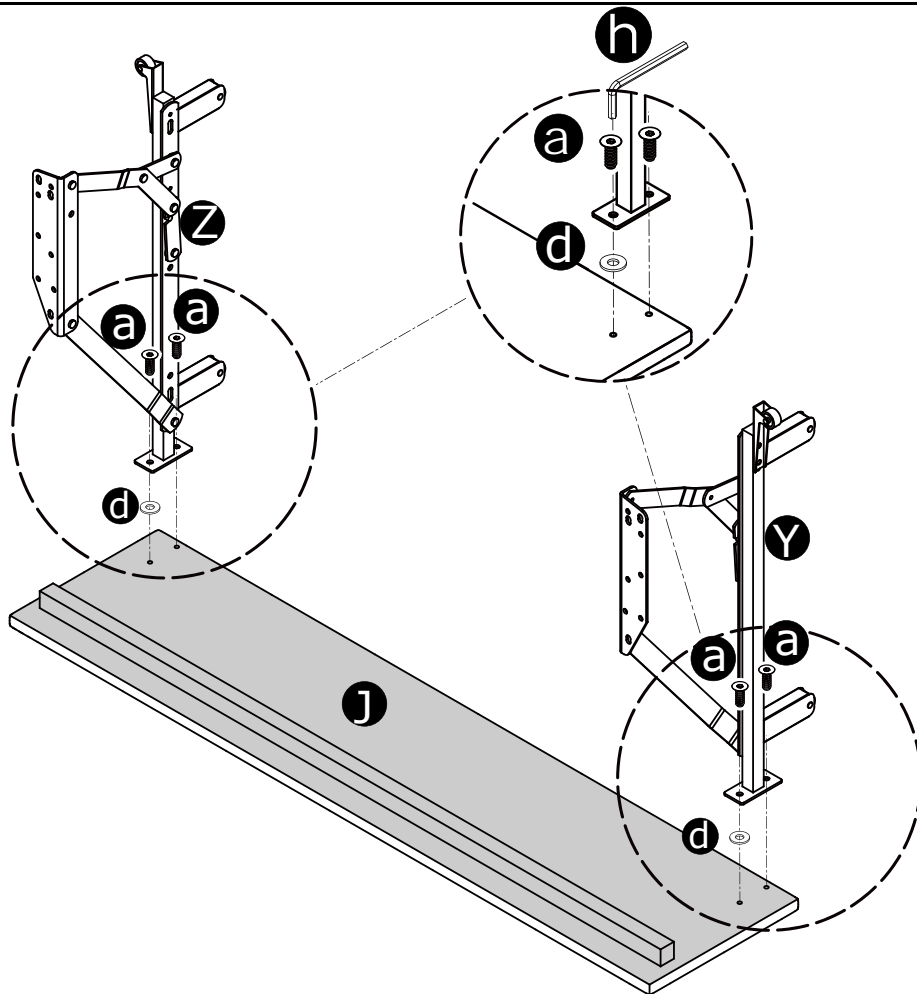

### STEP 33

**a** x4

**T3** x1

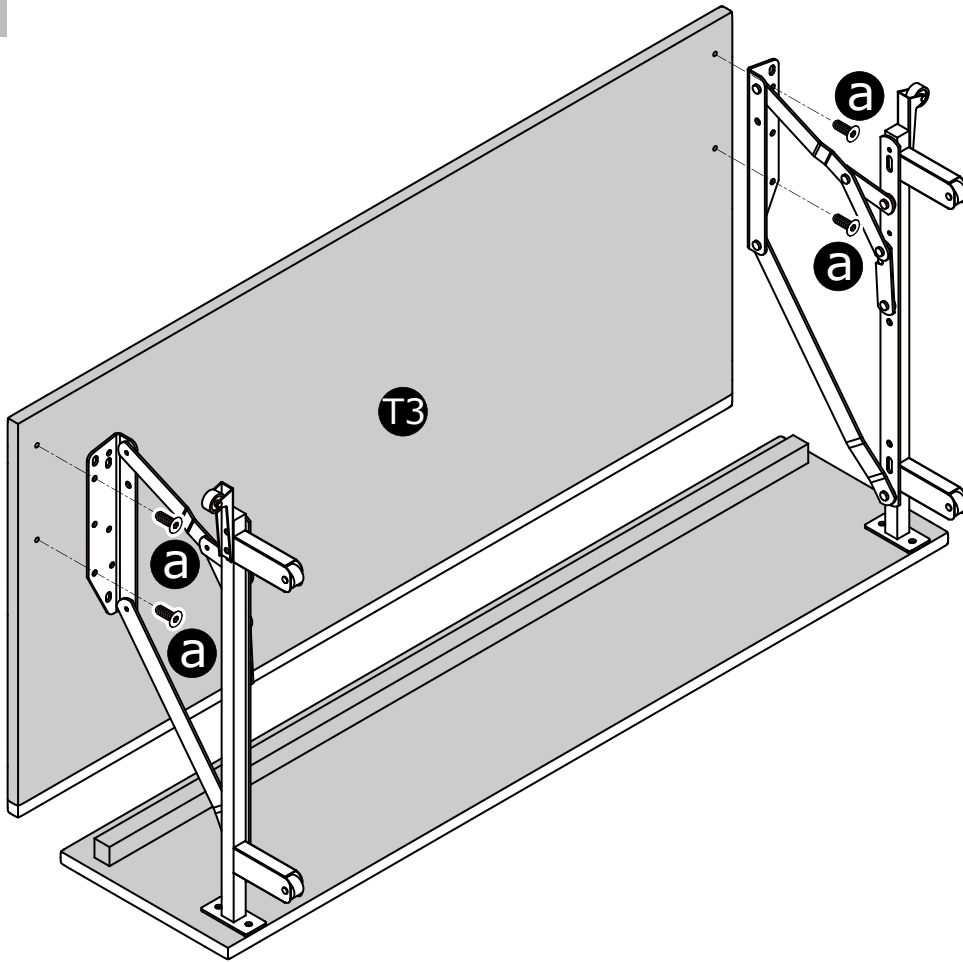

### STEP 34

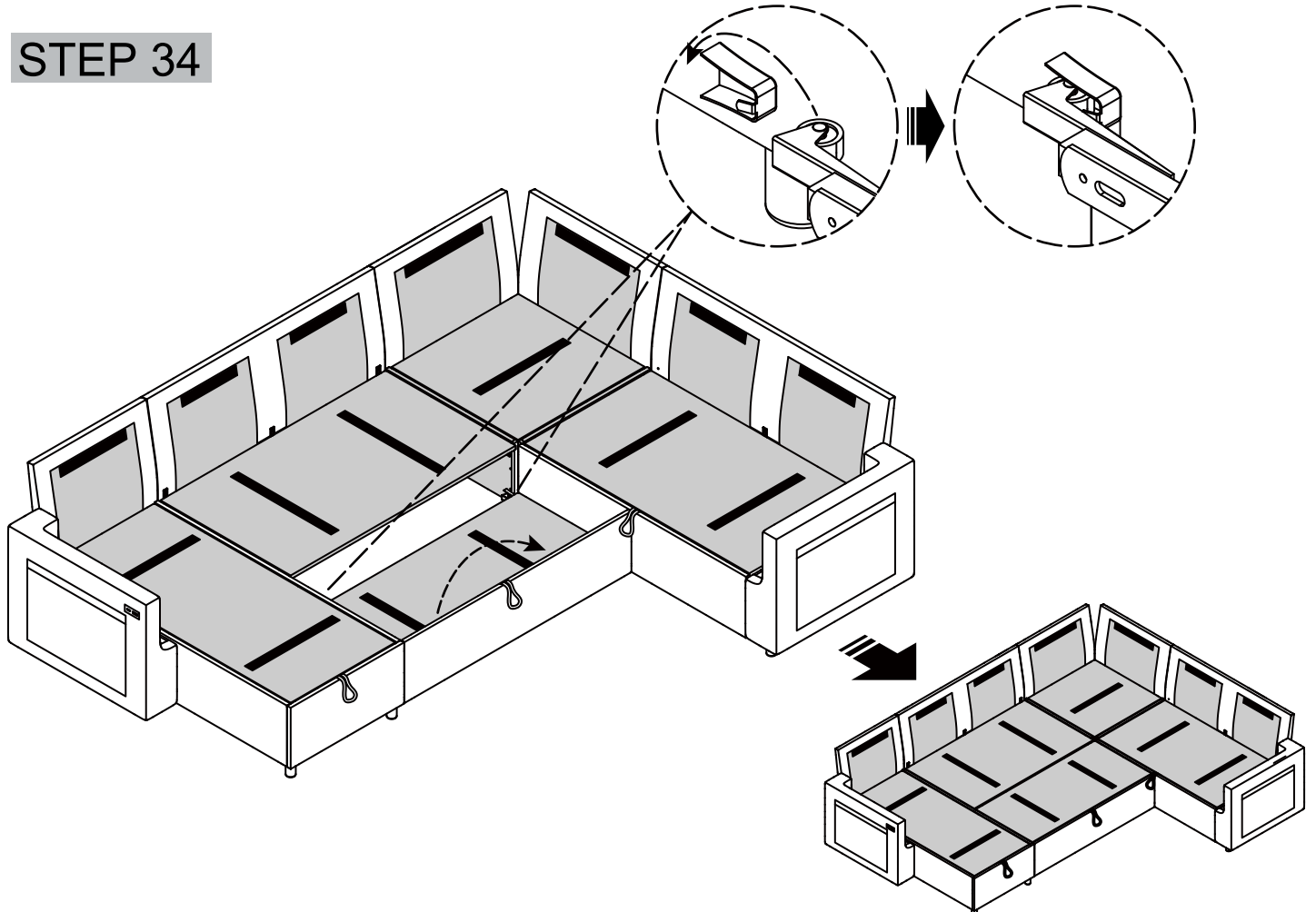

## STEP 35

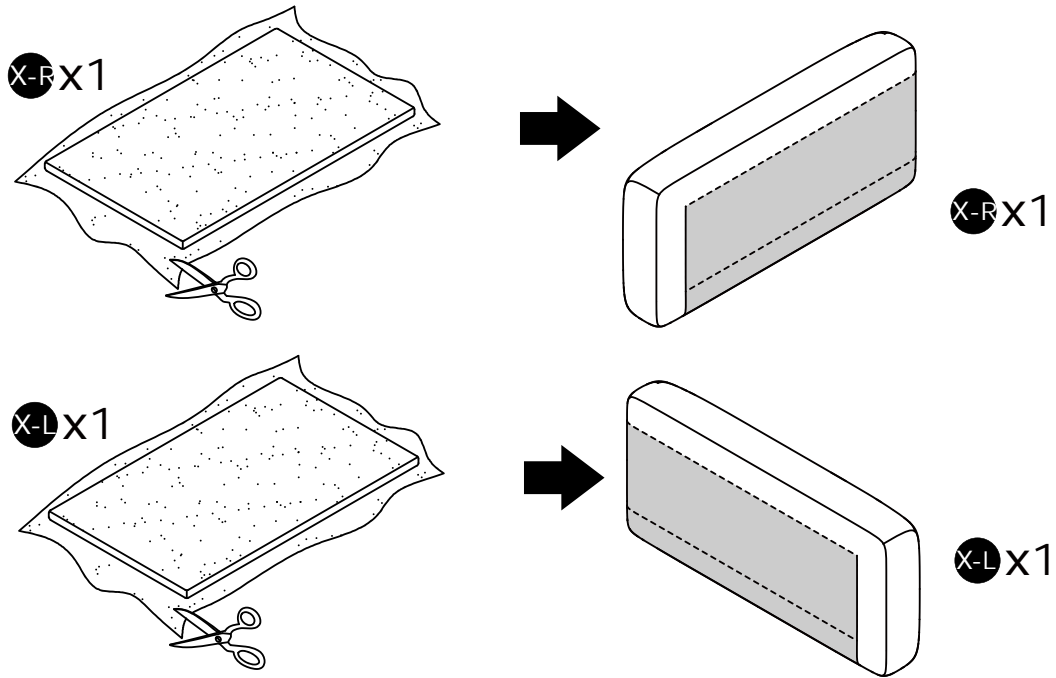

The product is compression parts,  
Please pat them by hand and wait 72 hours, the cushions will be recover.

## STEP 36

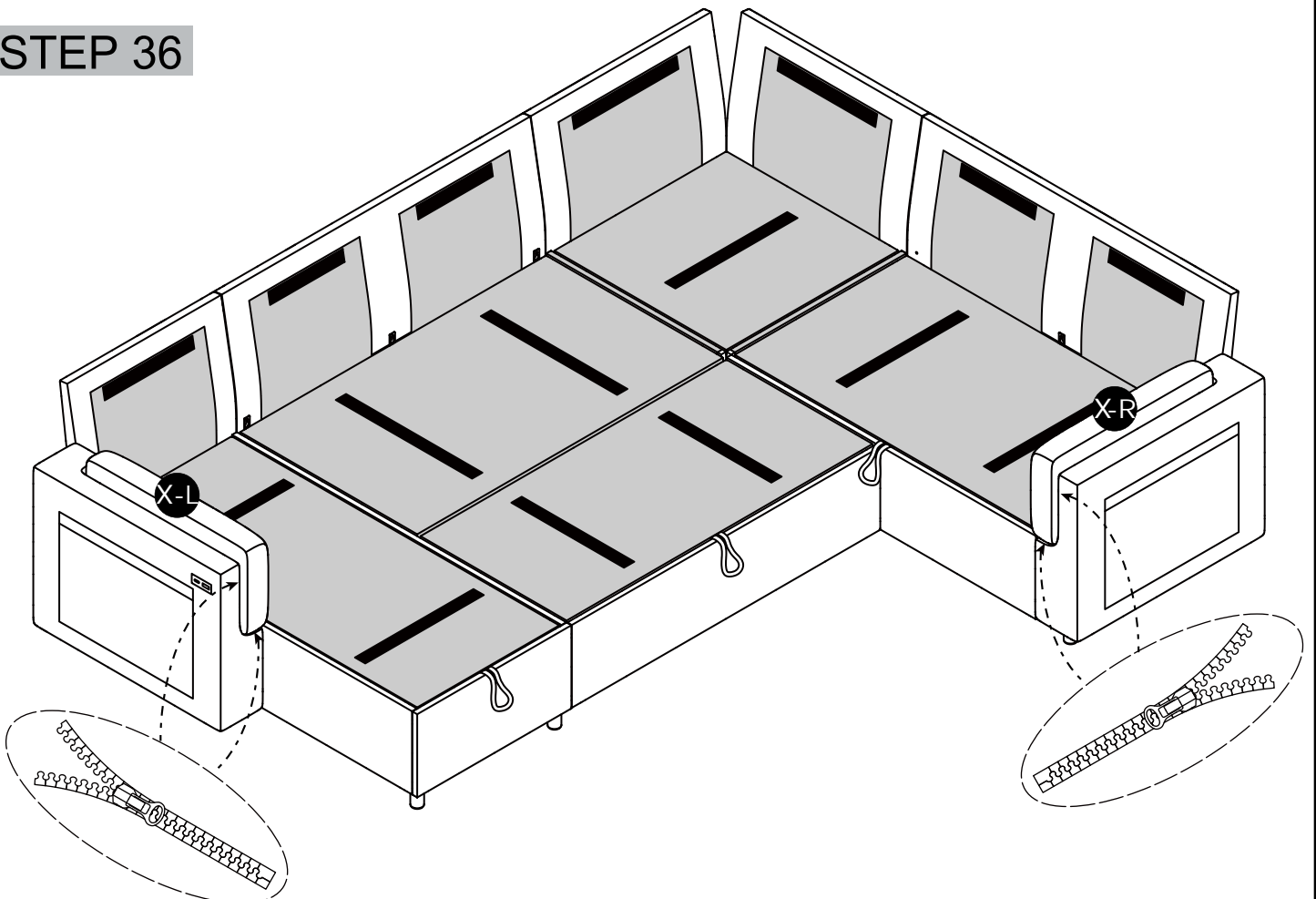

## STEP 35

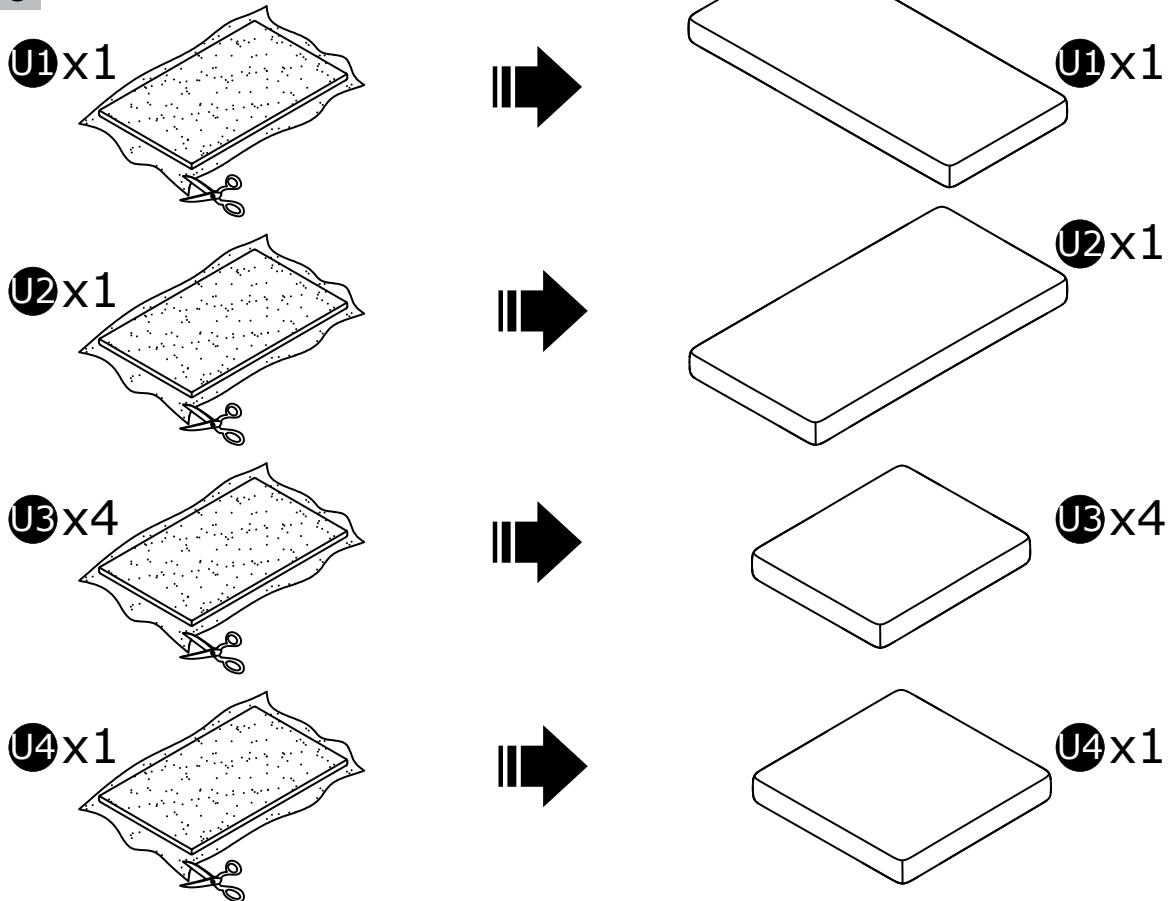

The product is compression parts,  
Please pat them by hand and wait 72 hours, the cushions will be recover.

## STEP 36

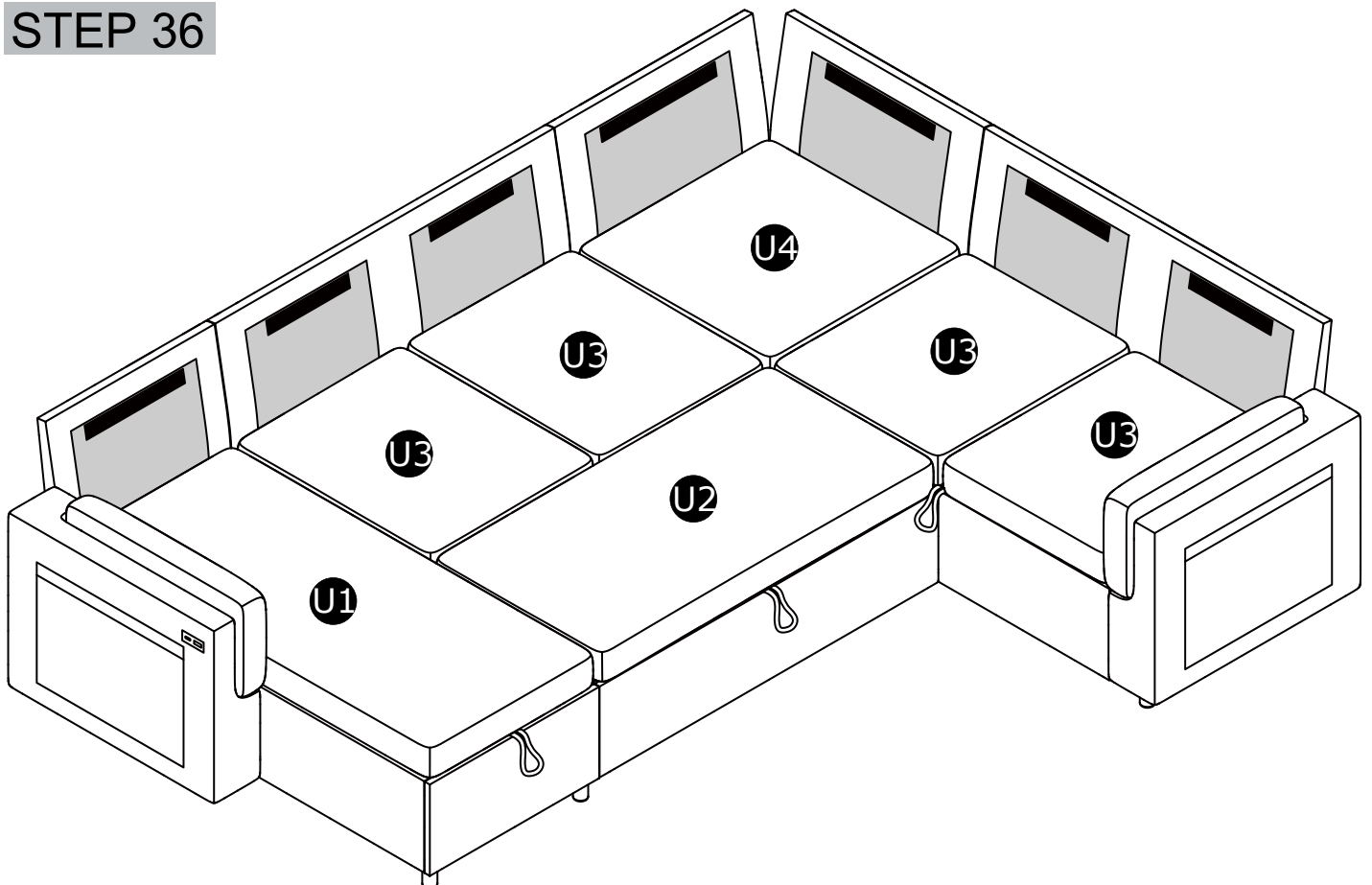

## STEP 37

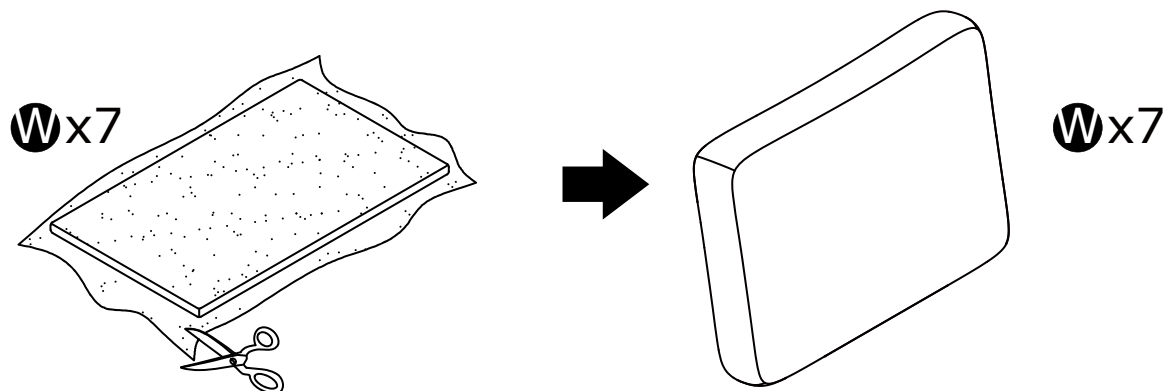

The product is compression parts,  
Please pat them by hand and wait 72 hours, the cushions will be recover.

## STEP 38

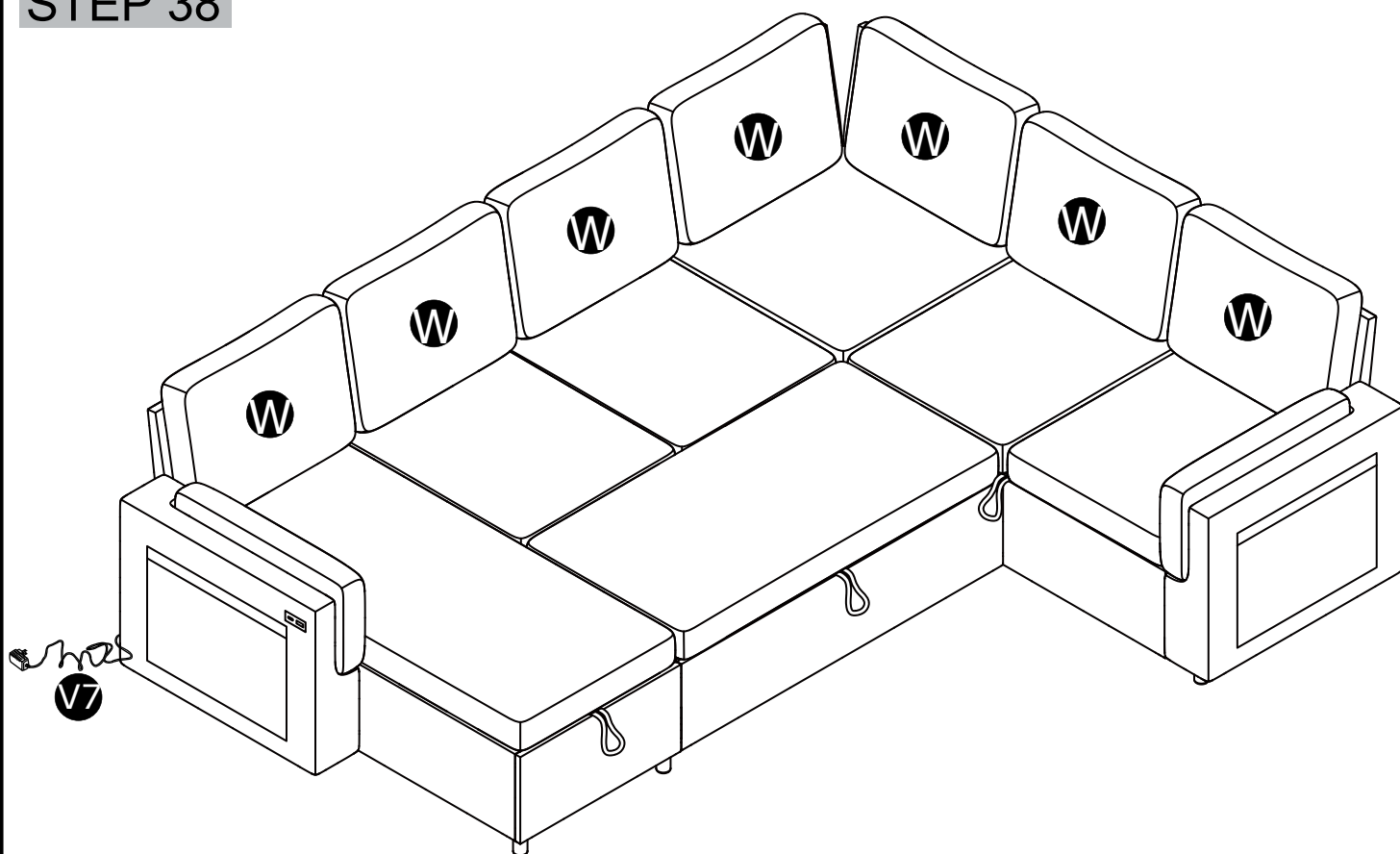

## 2 Sofa Overall Assembly Drawing

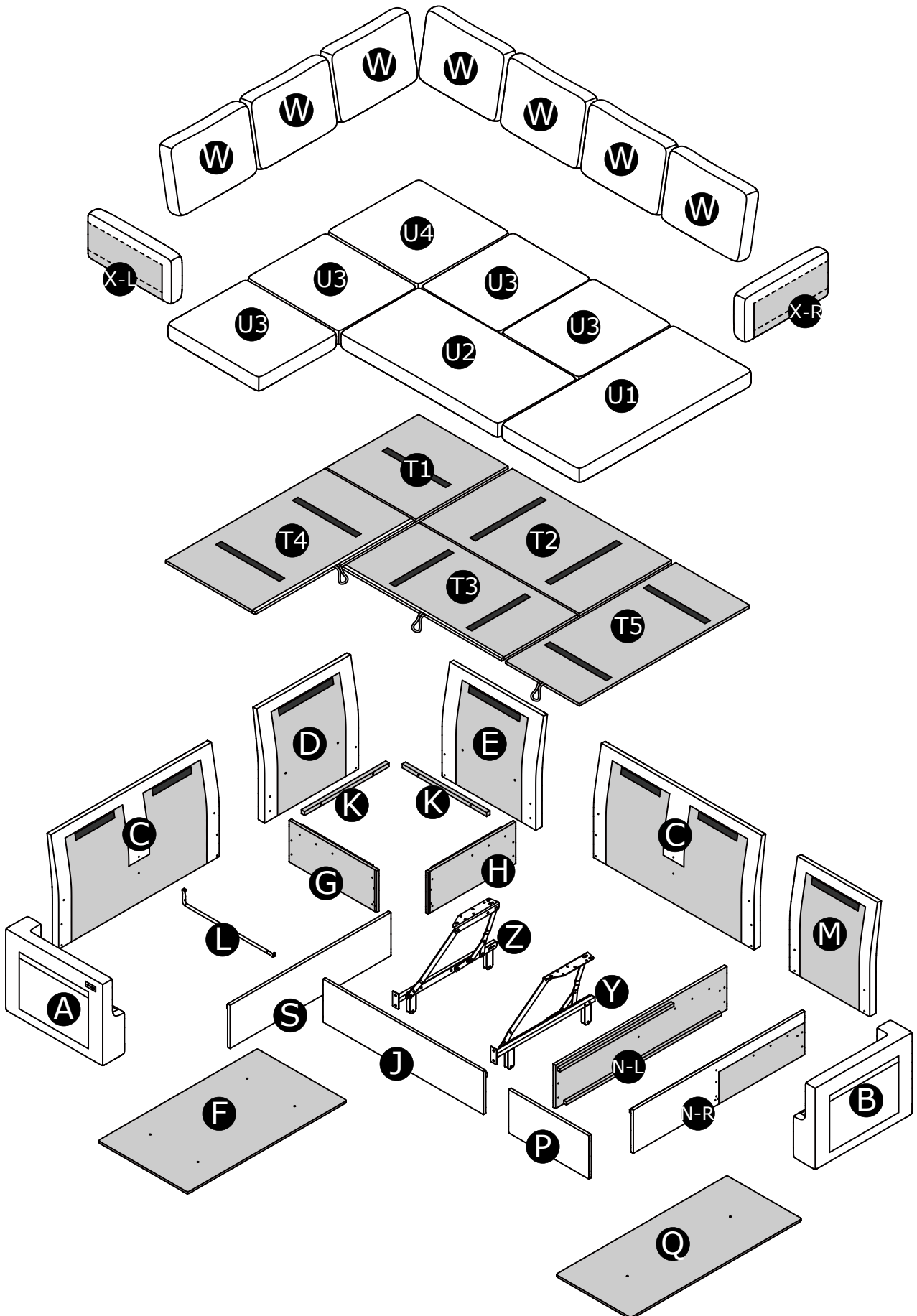

some parts are inside 2 armrests, please take some out

# STEP 1

**H** x1

**G** x1

**V5** x3

**b** x6

**h** x1

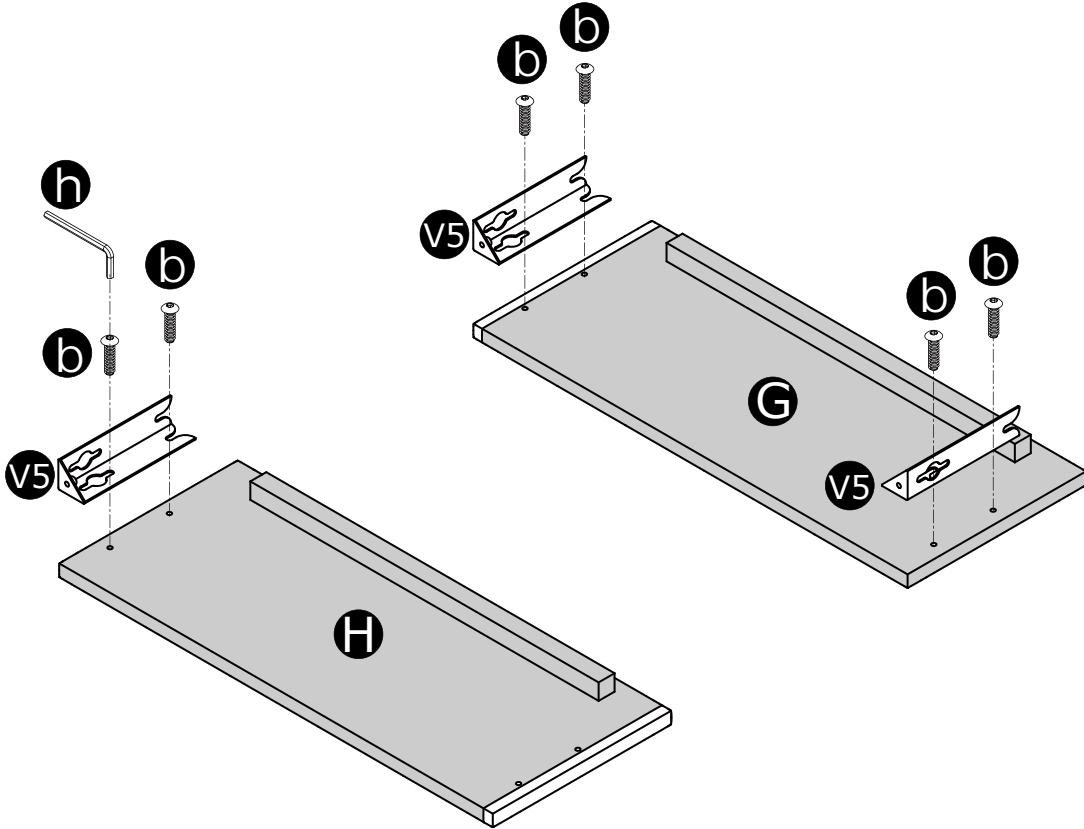

# STEP 2

**a** x2

**h** x1

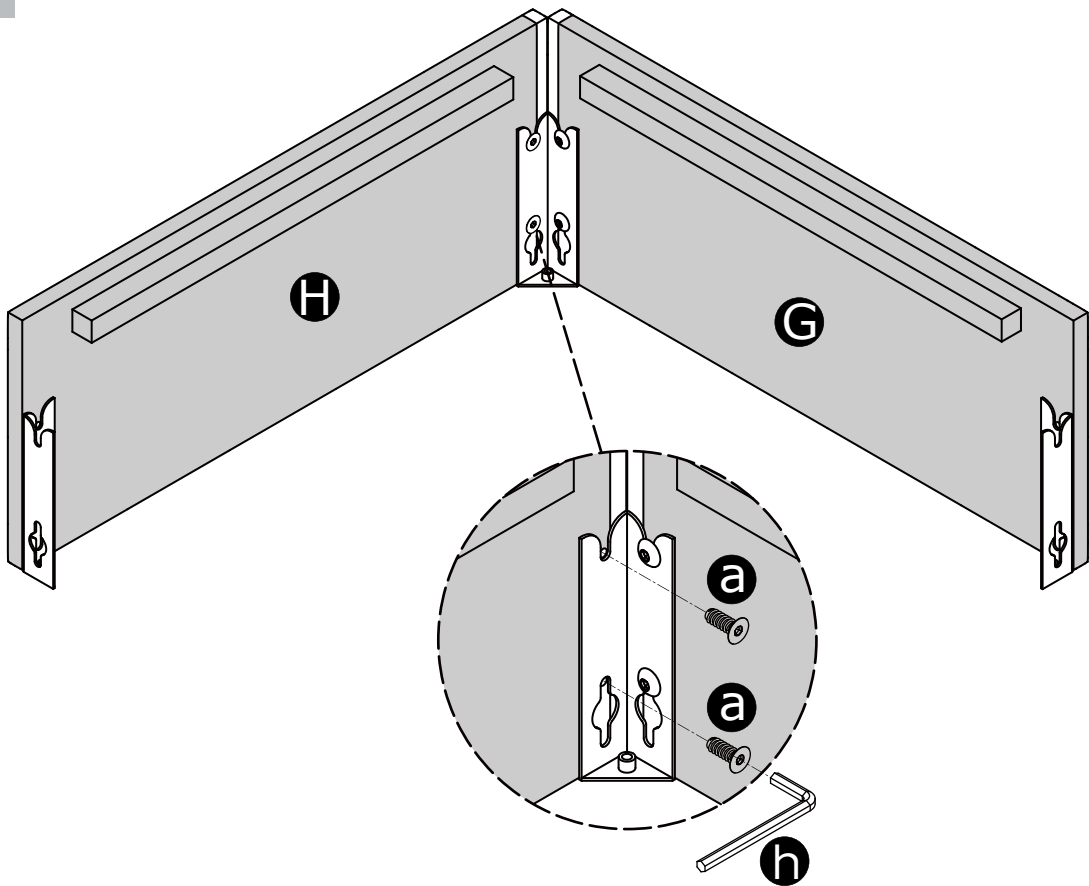

### STEP 3

**D** x1

**E** x1

**K** x2

**b** x4

**d** x4

**h** x1

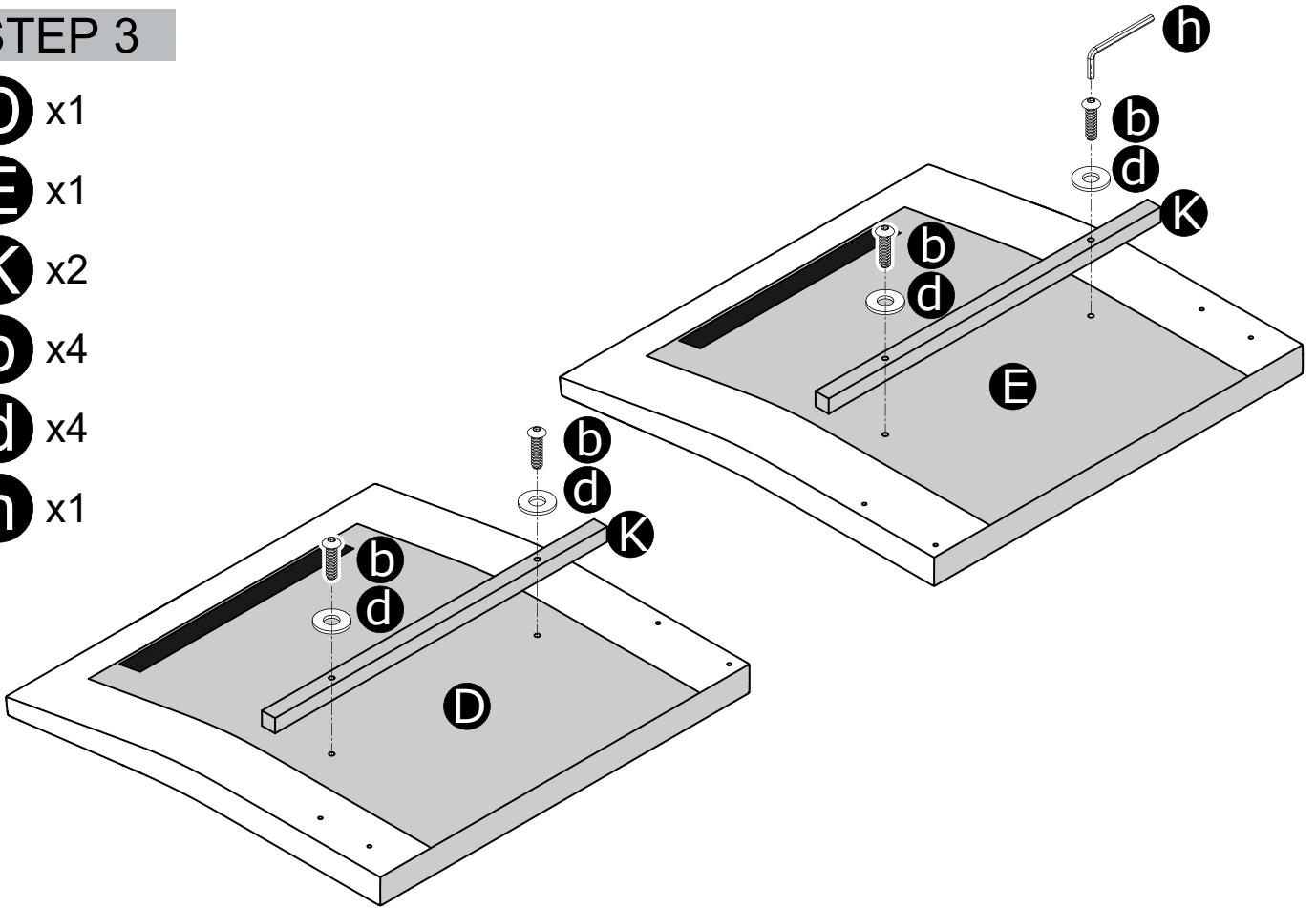

### STEP 4

**V5** x1

**a** x4

**h** x1

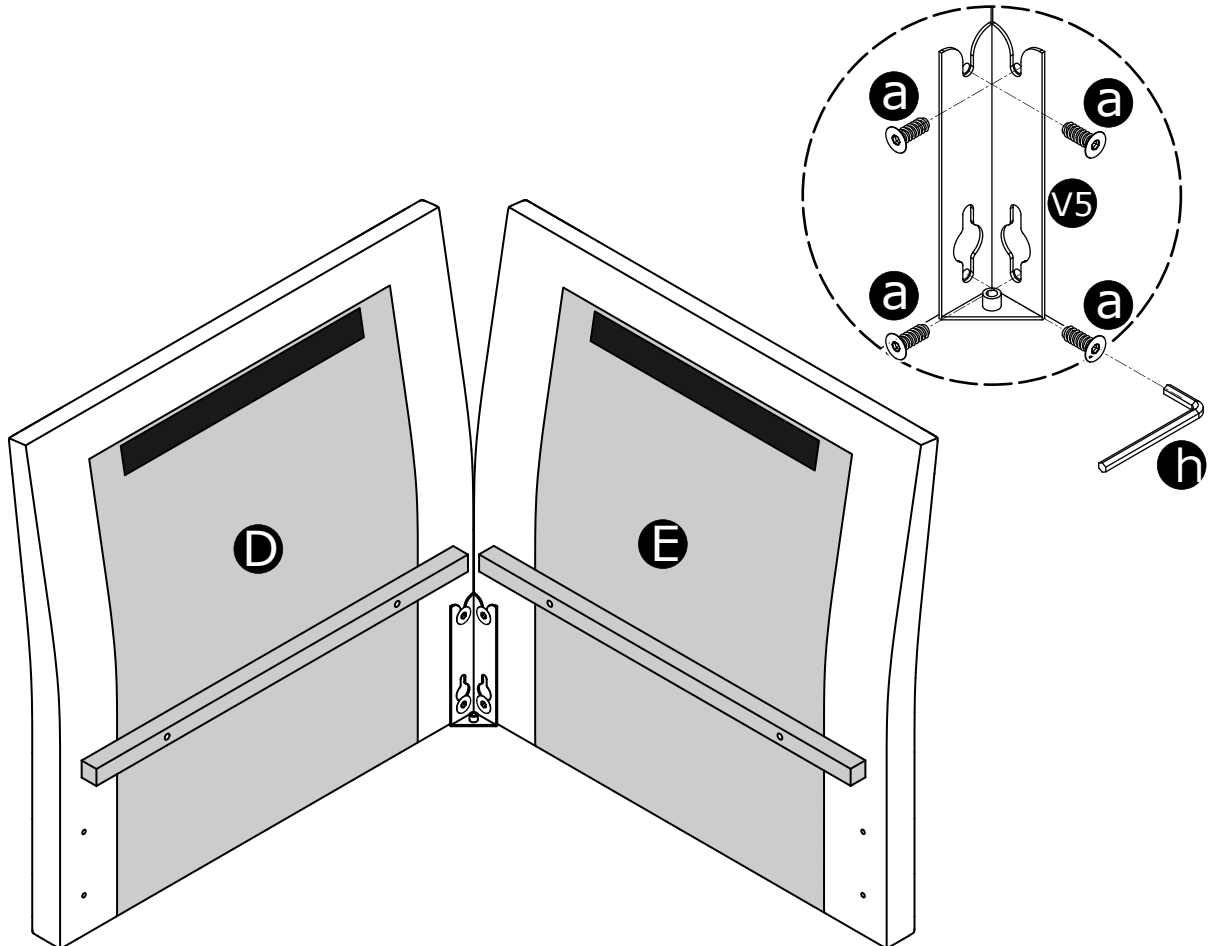

## STEP 5

**a** x4

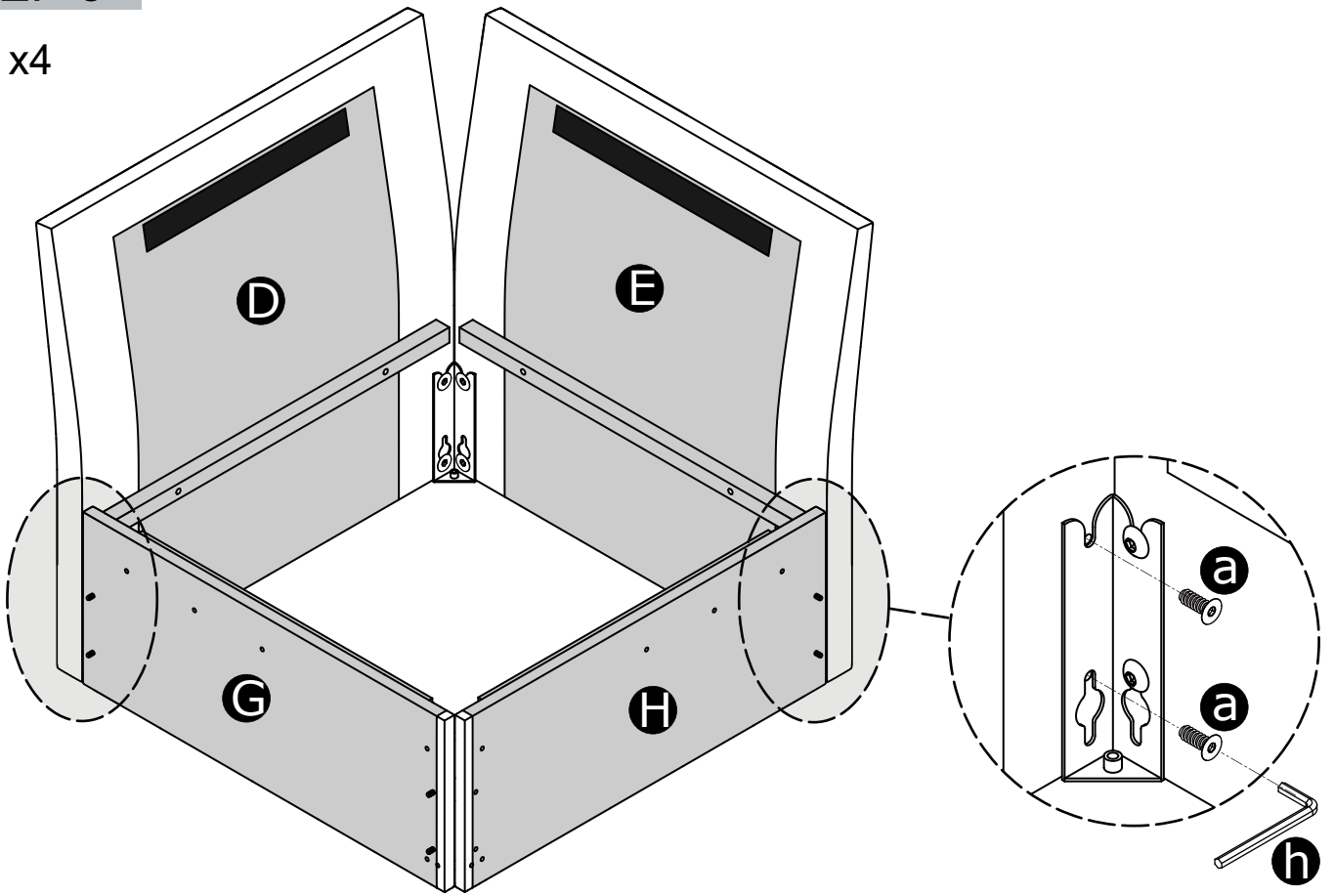

## STEP 6

**V2** x4

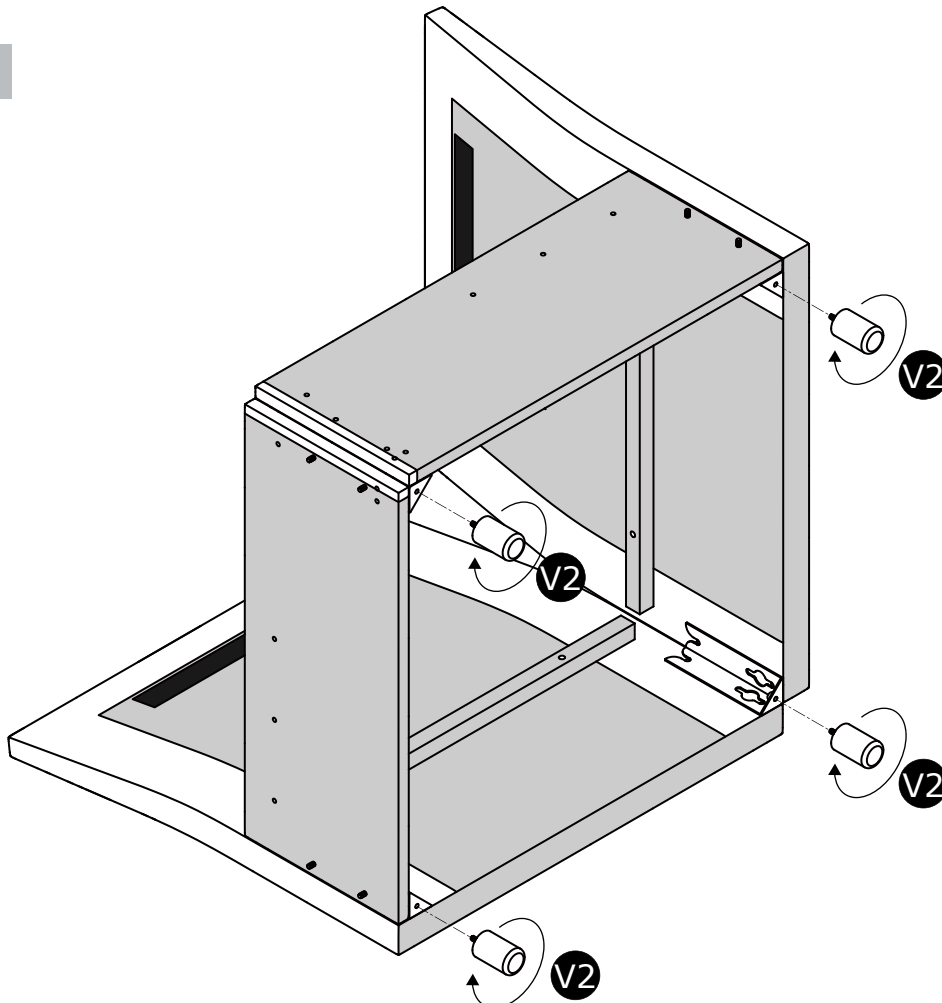

## STEP 7

**C** x1

**S** x1

**V5** x4

**a** x8

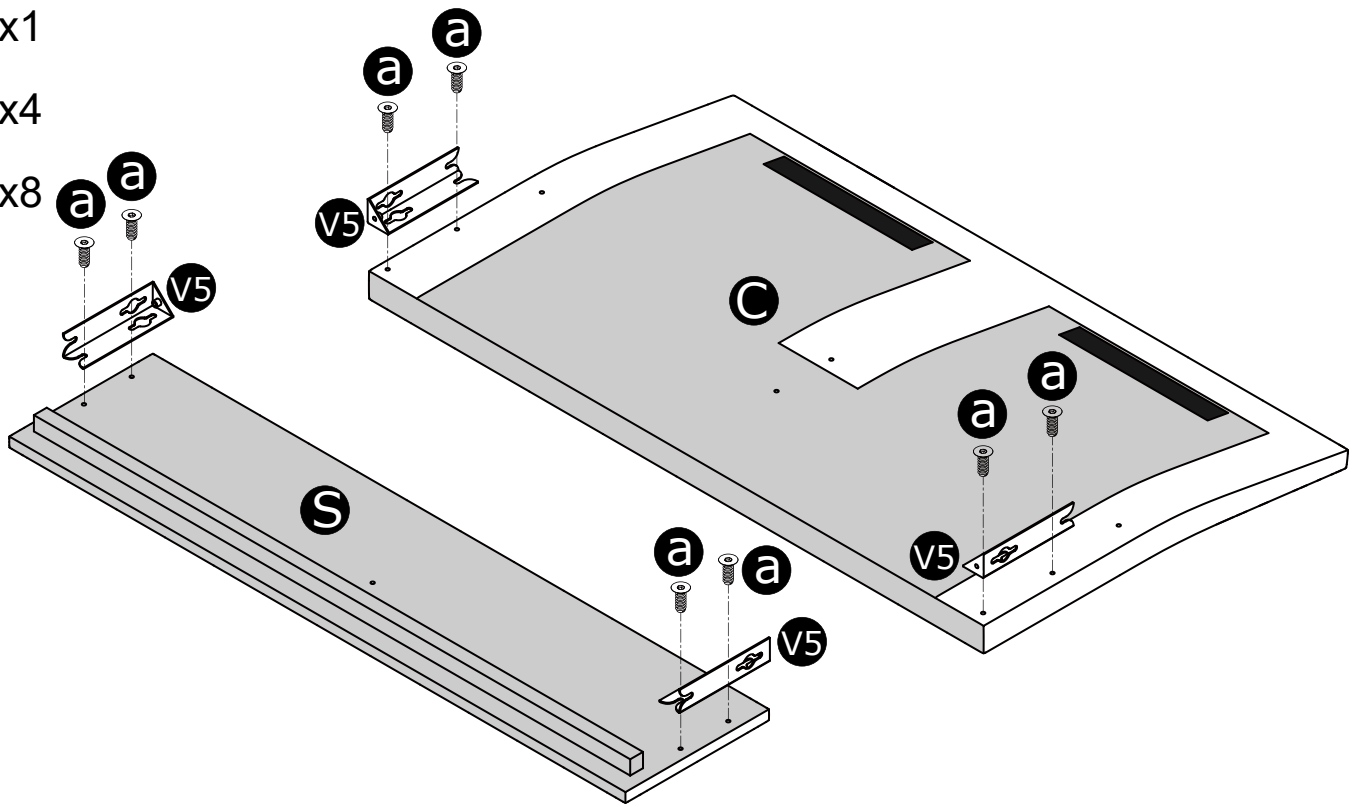

## STEP 8

**A** x1

**V2** x2

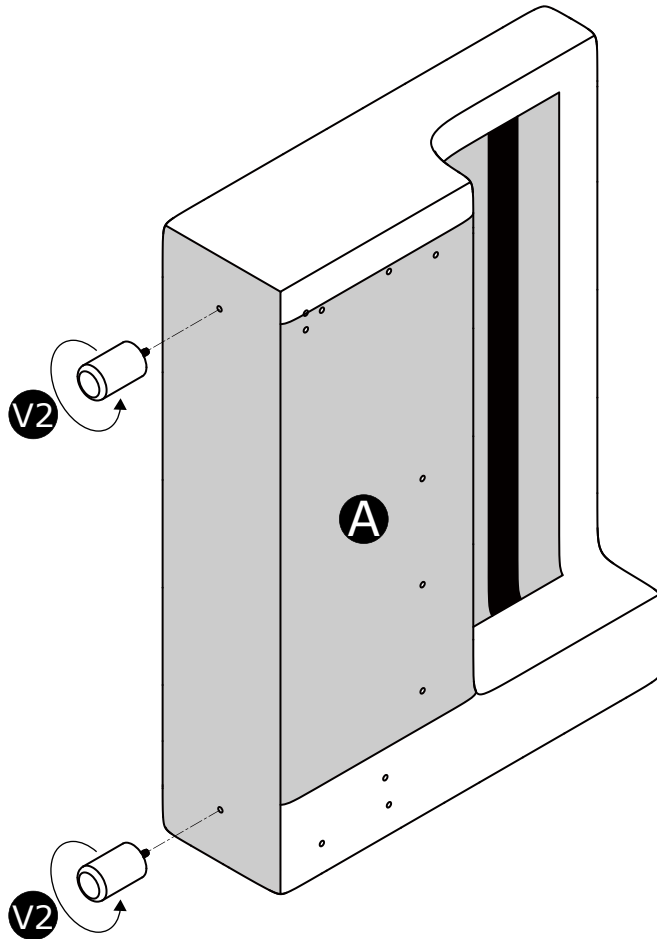

### STEP 9

**a** x4

**h** x1

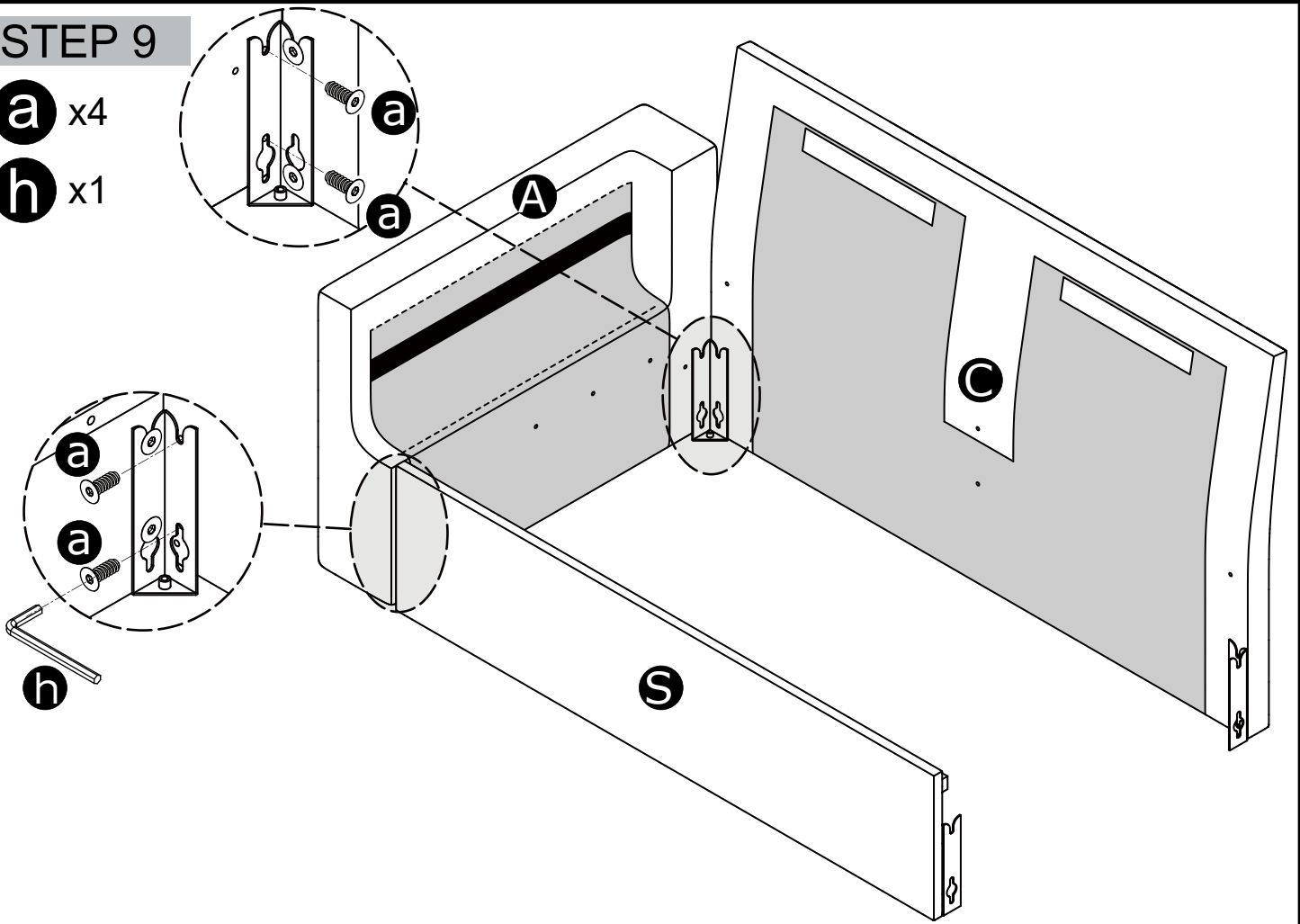

### STEP 10

**c** x4

**d** x4

**f** x1

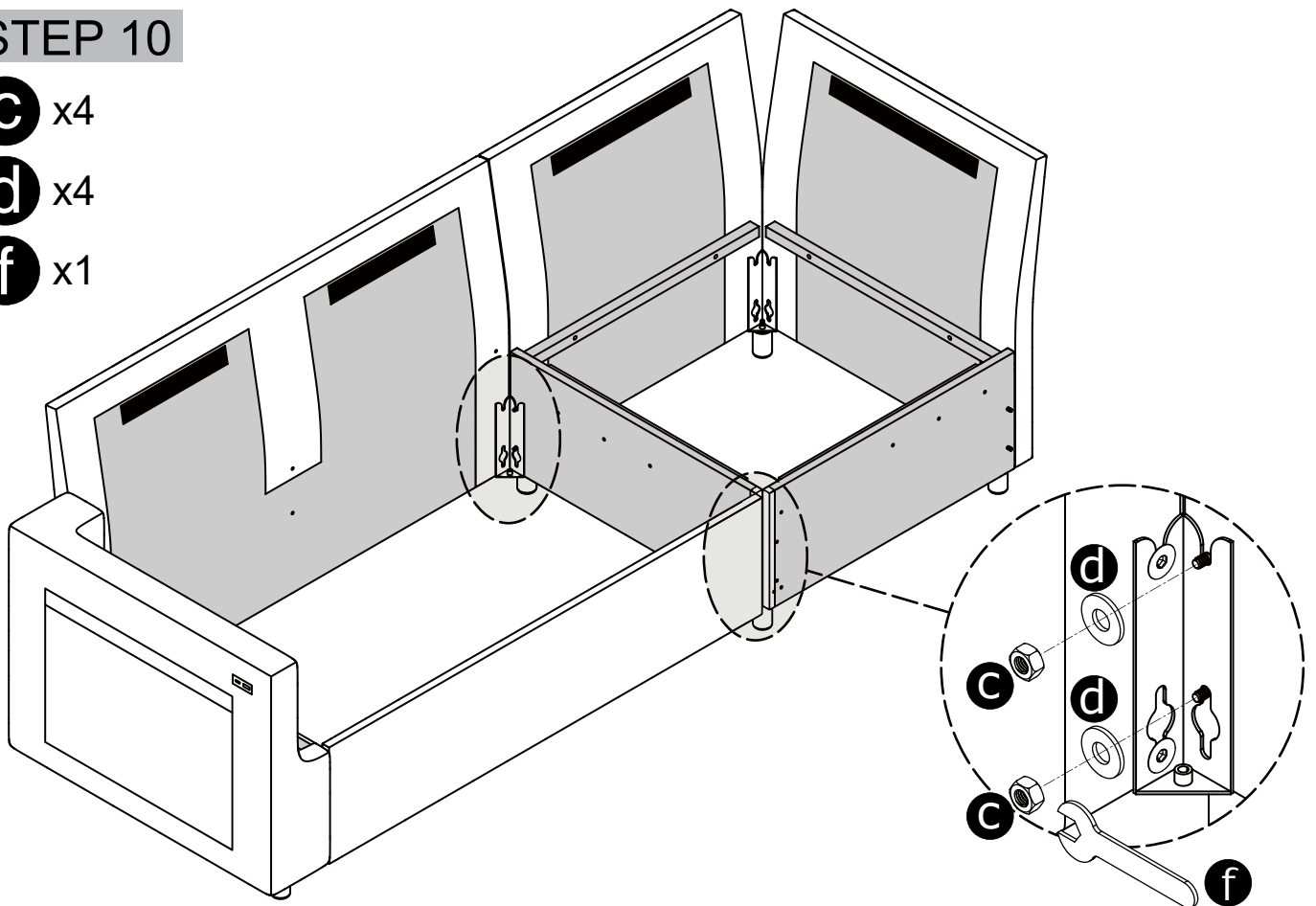

## STEP 11

**F** x1

**a** x4

**d** x4

**V6** x4

**h** x1

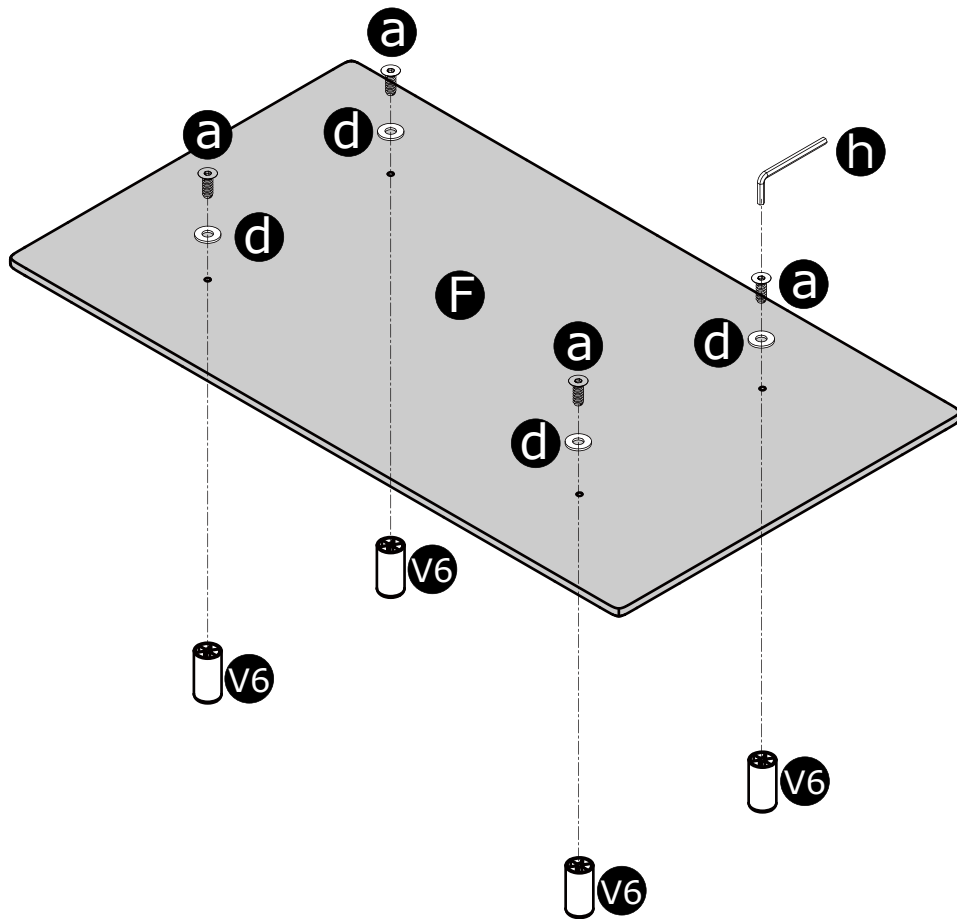

## STEP 12

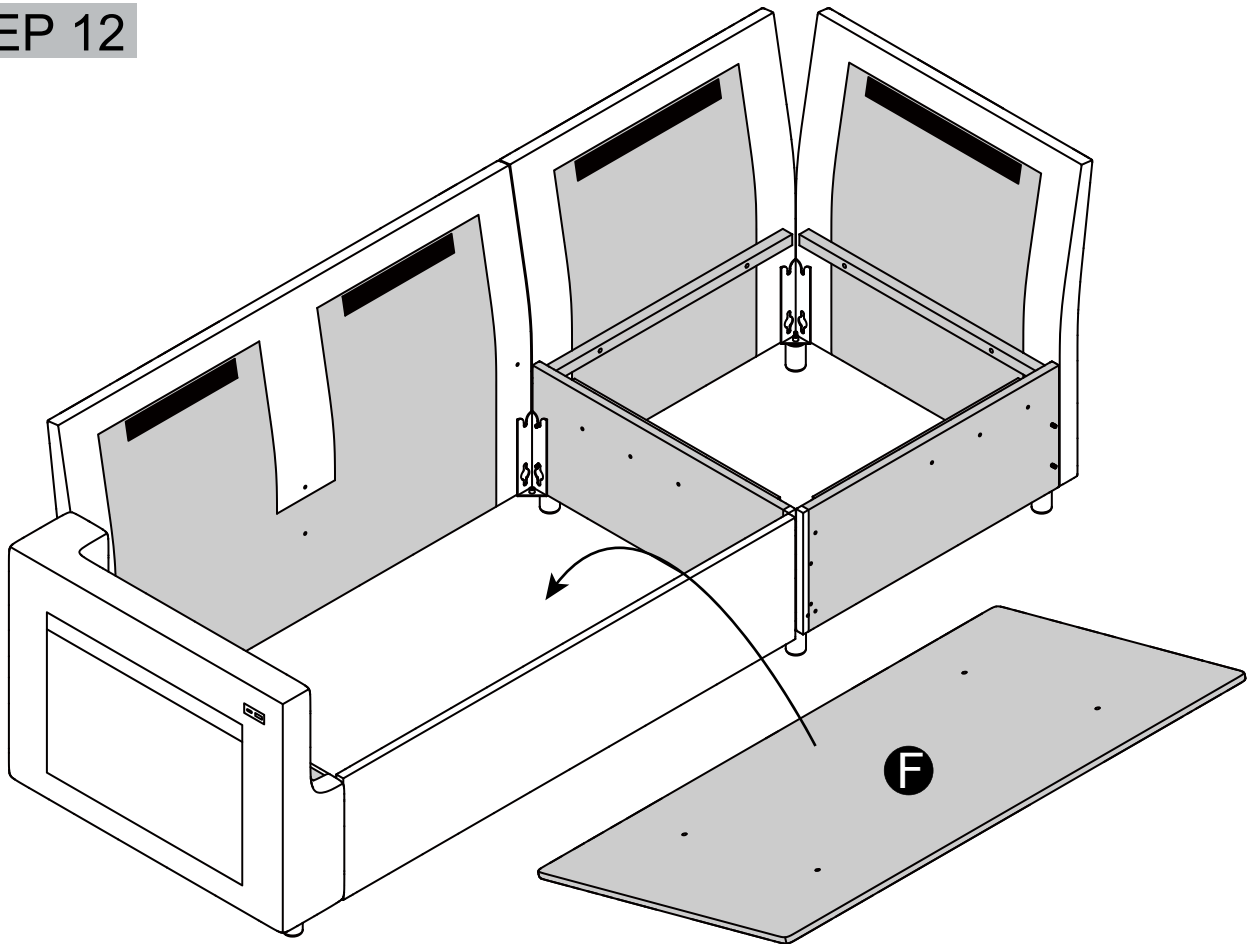

### STEP 13

- a** x2
- b** x2
- c** x1
- L** x1
- V1** x1
- f** x1
- h** x1

STEP1

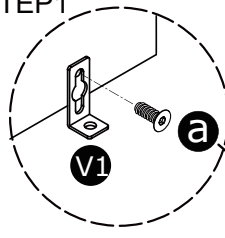

STEP2

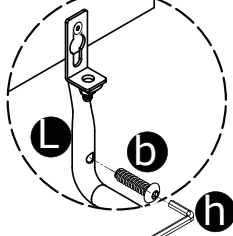

STEP4

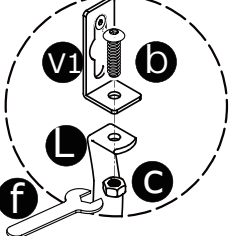

STEP3

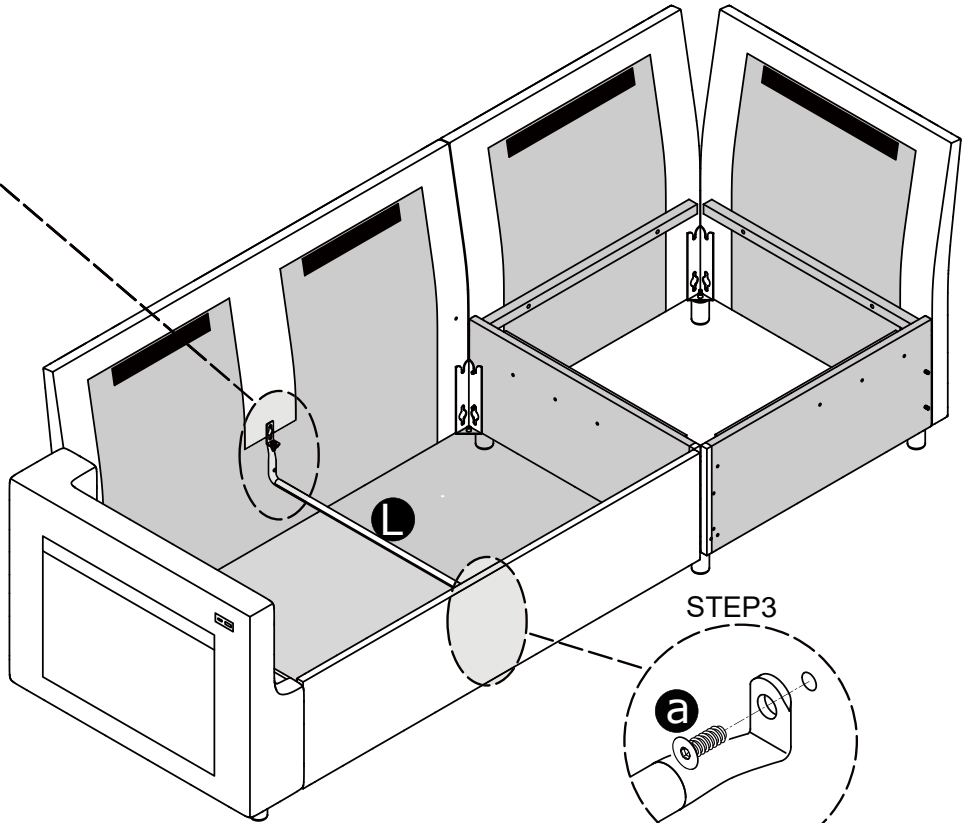
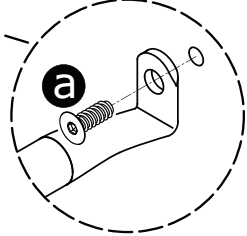

### STEP 14

- T4** x1
- R-L** x1
- R-R** x1
- a** x4
- h** x1

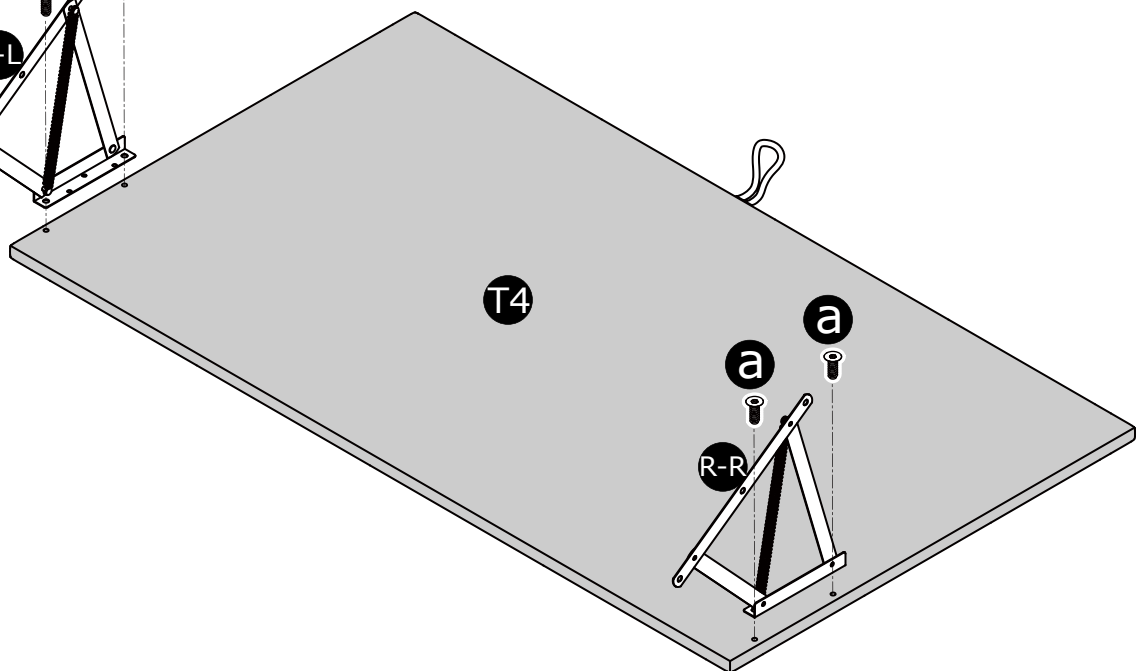
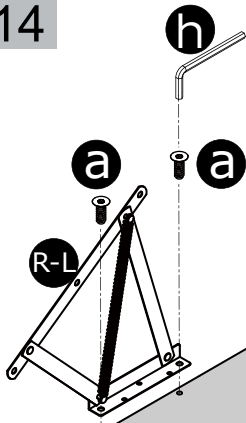

## STEP 15

**a** x6

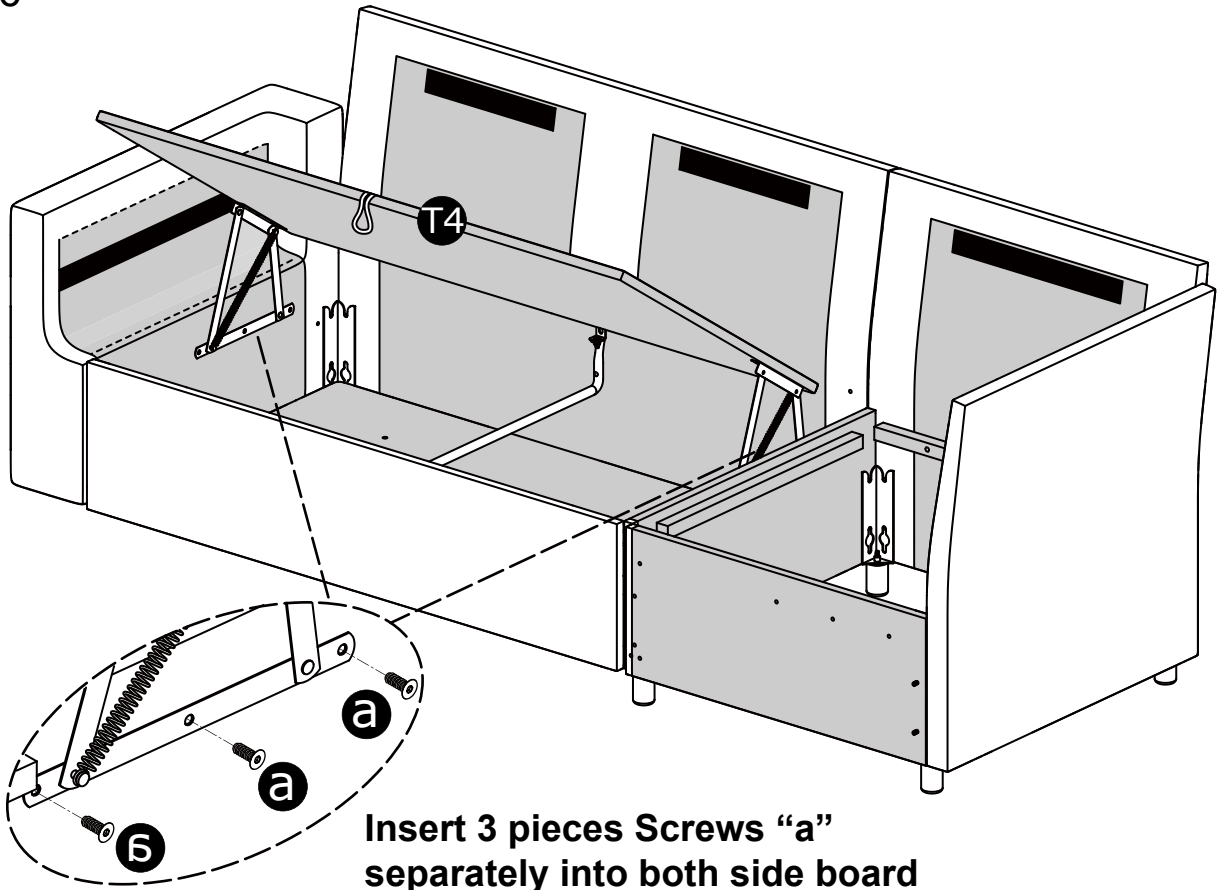

Insert 3 pieces Screws "a"  
separately into both side board

## STEP 16

**V5** x1 **V3** x1  
**C** x2 **a** x3  
**d** x2 **h** x1  
**f** x1  
**T1** x1

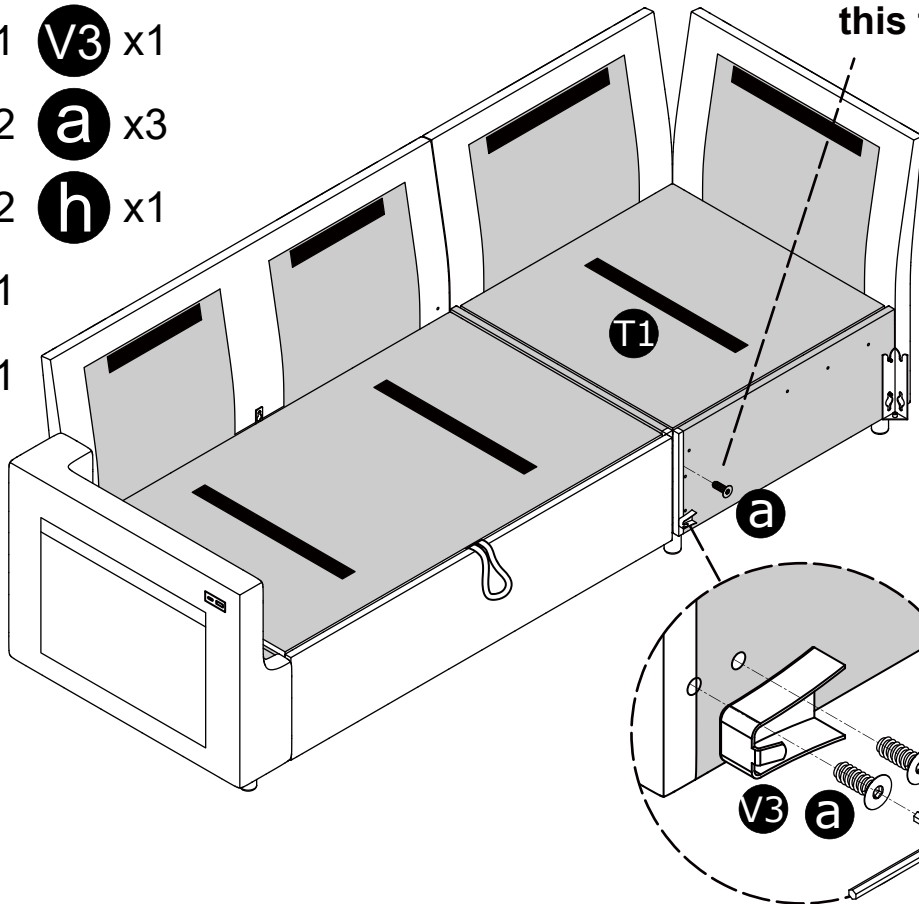

**!** Insert the screws, but do  
not tighten them fully at  
this time.

## STEP 17

**N-L** x1

**N-R** x1

**V5** x4

**a** x6

**b** x2

**h** x1

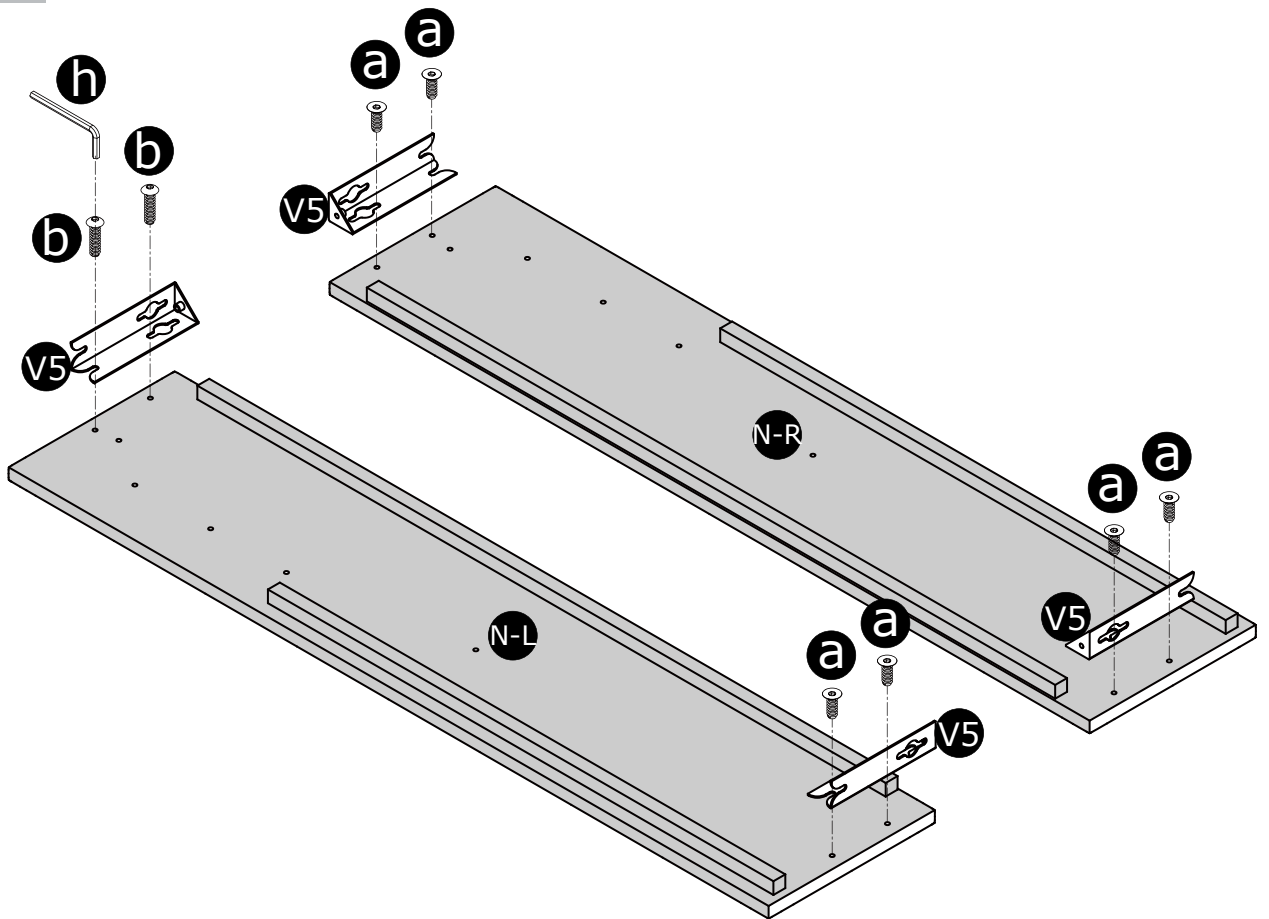

## STEP 18

**B** x1

**b** x2

**d** x2

**h** x1

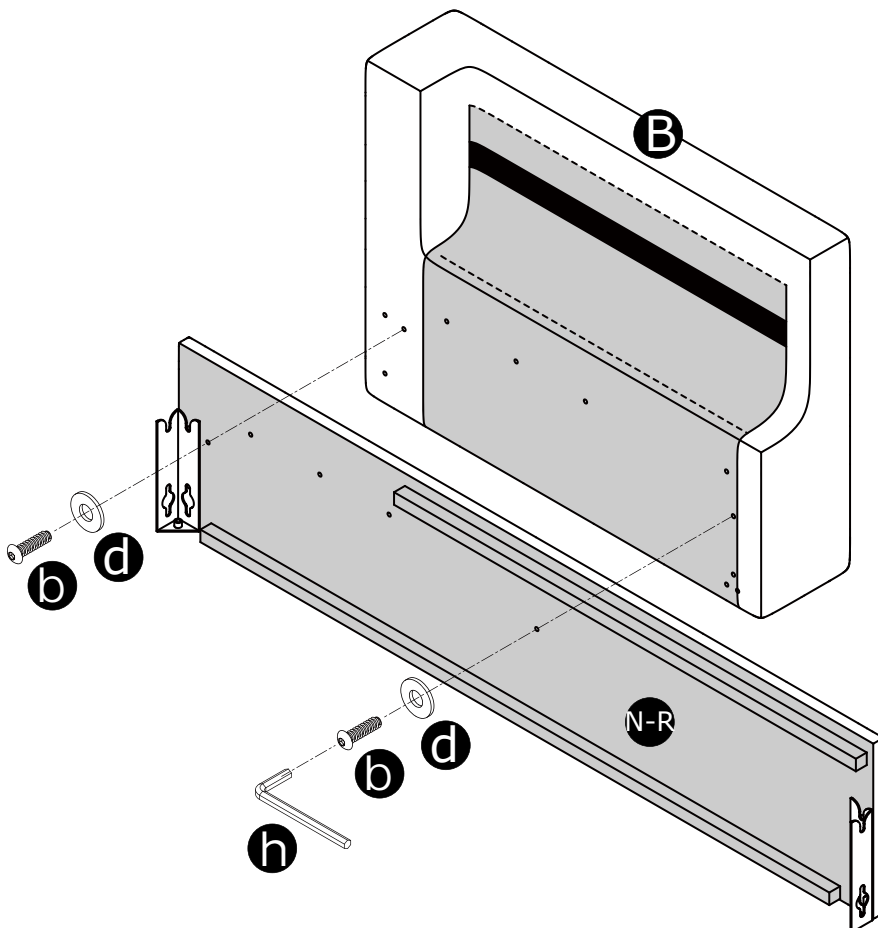

## STEP 19

- M** x1
- P** x1
- a** x8
- h** x1

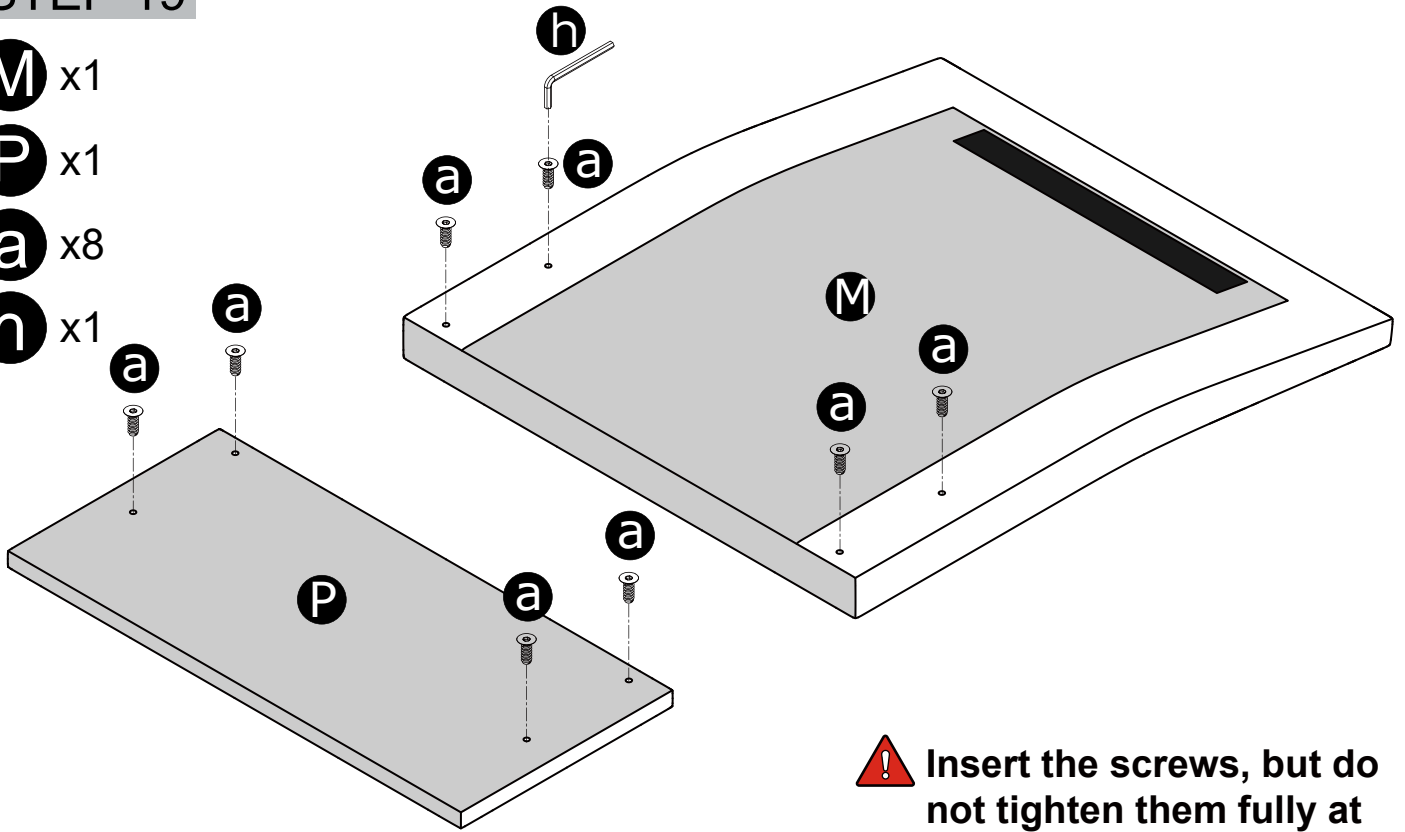

**!** Insert the screws, but do not tighten them fully at this time.

## STEP 20

**!** Slide the screws "a" into part "P" and tighten them at this time

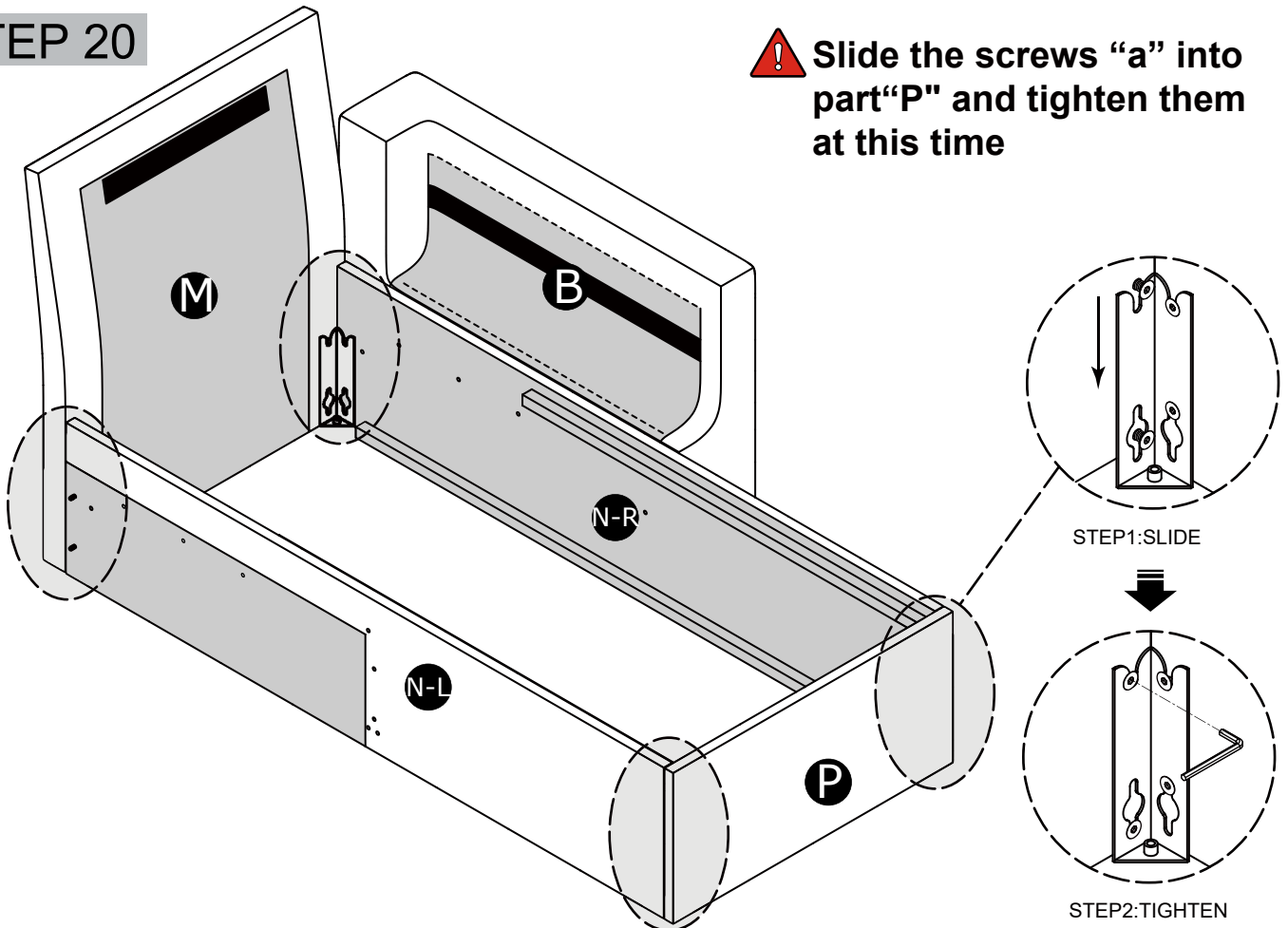

## STEP 21

**V2** x4

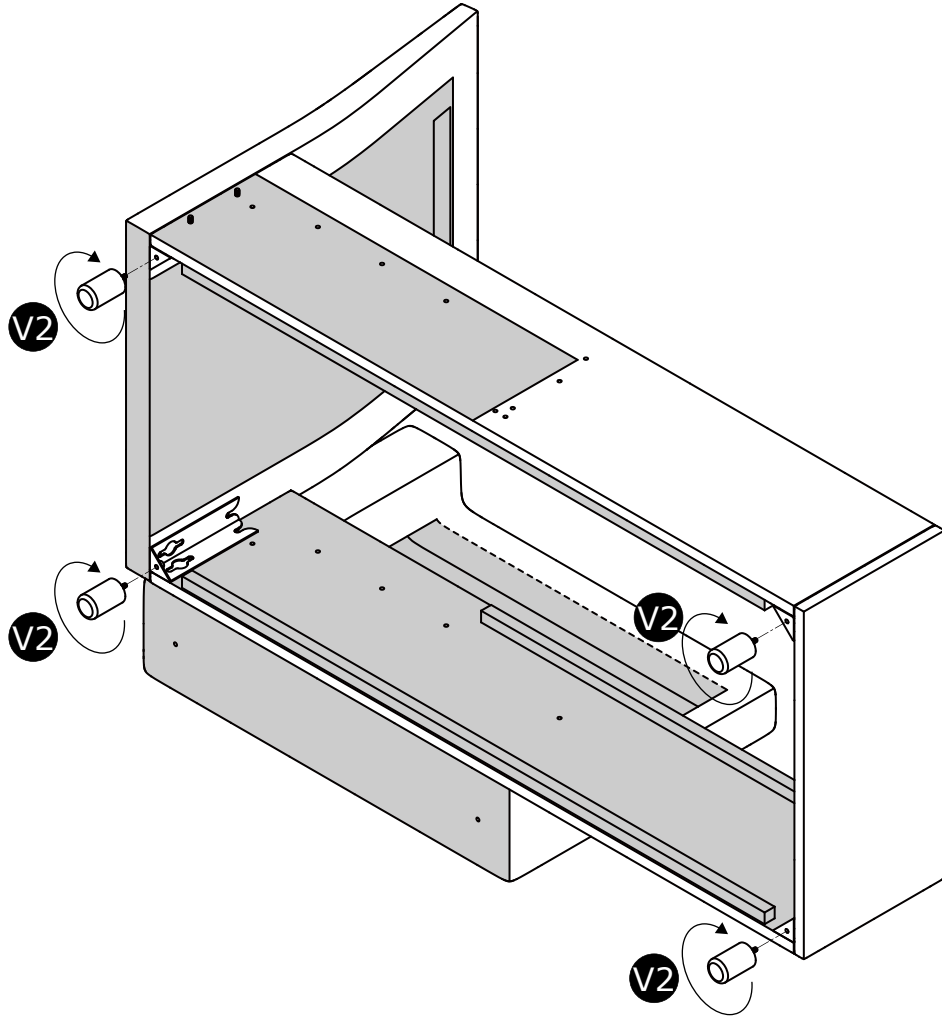

## STEP 22

**Q** x1

**a** x2

**d** x2

**V6** x2

**h** x1

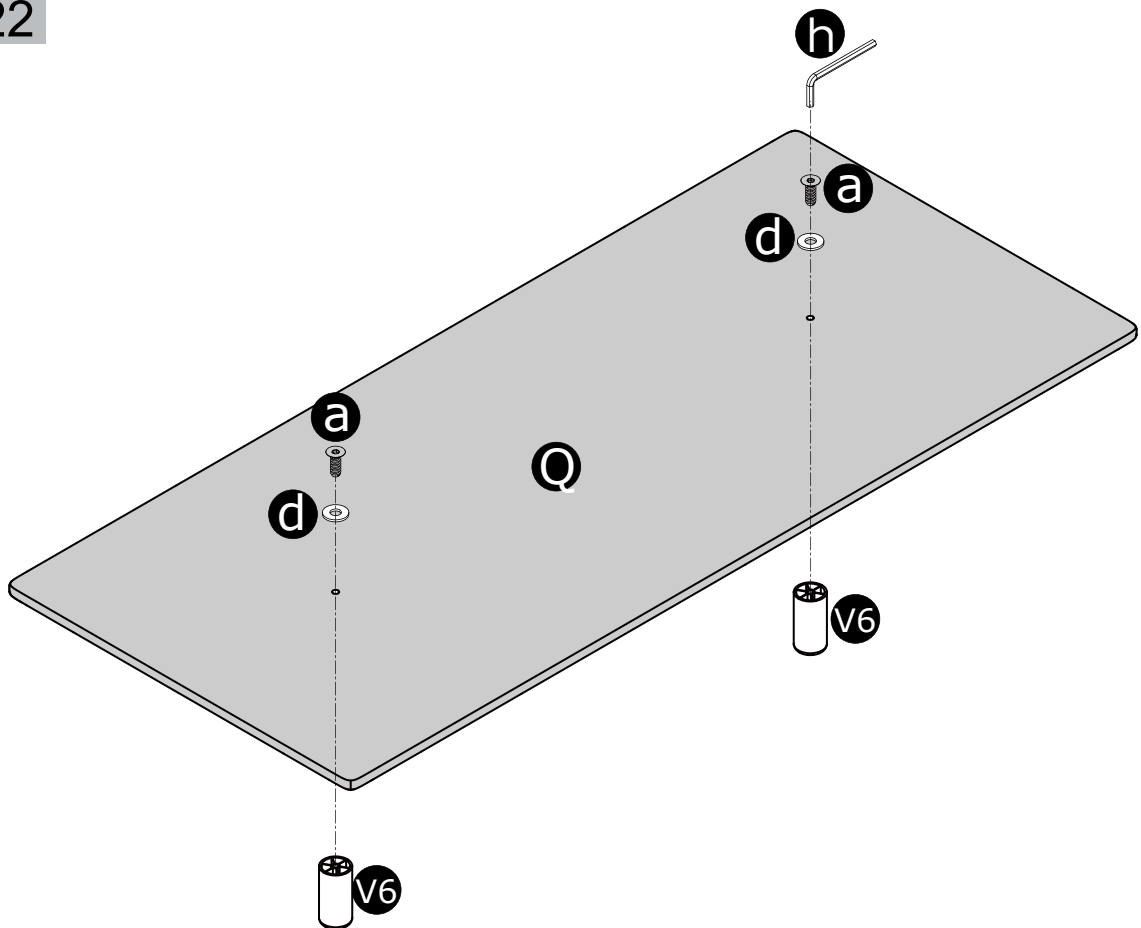

# STEP 23

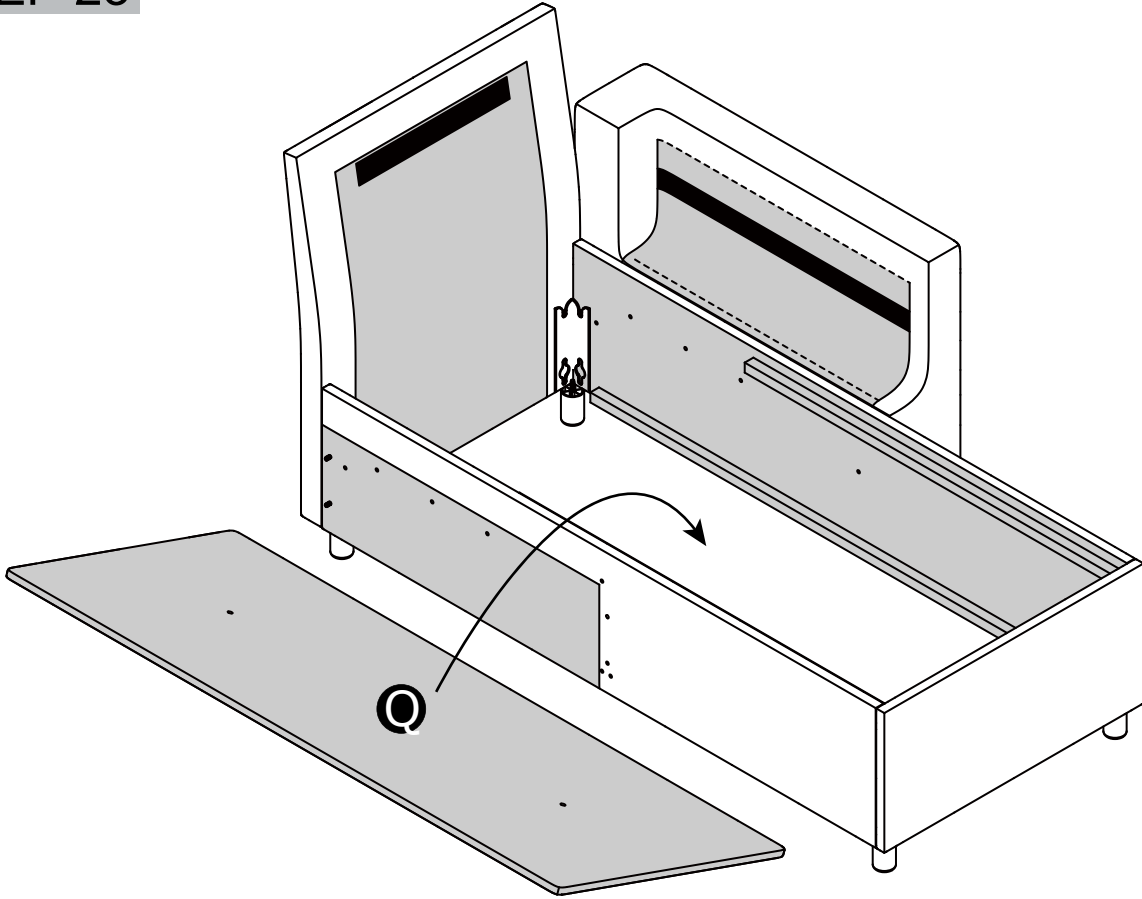

# STEP 24

**T5** x1

**R-L** x1

**R-R** x1

**a** x4

**h** x1

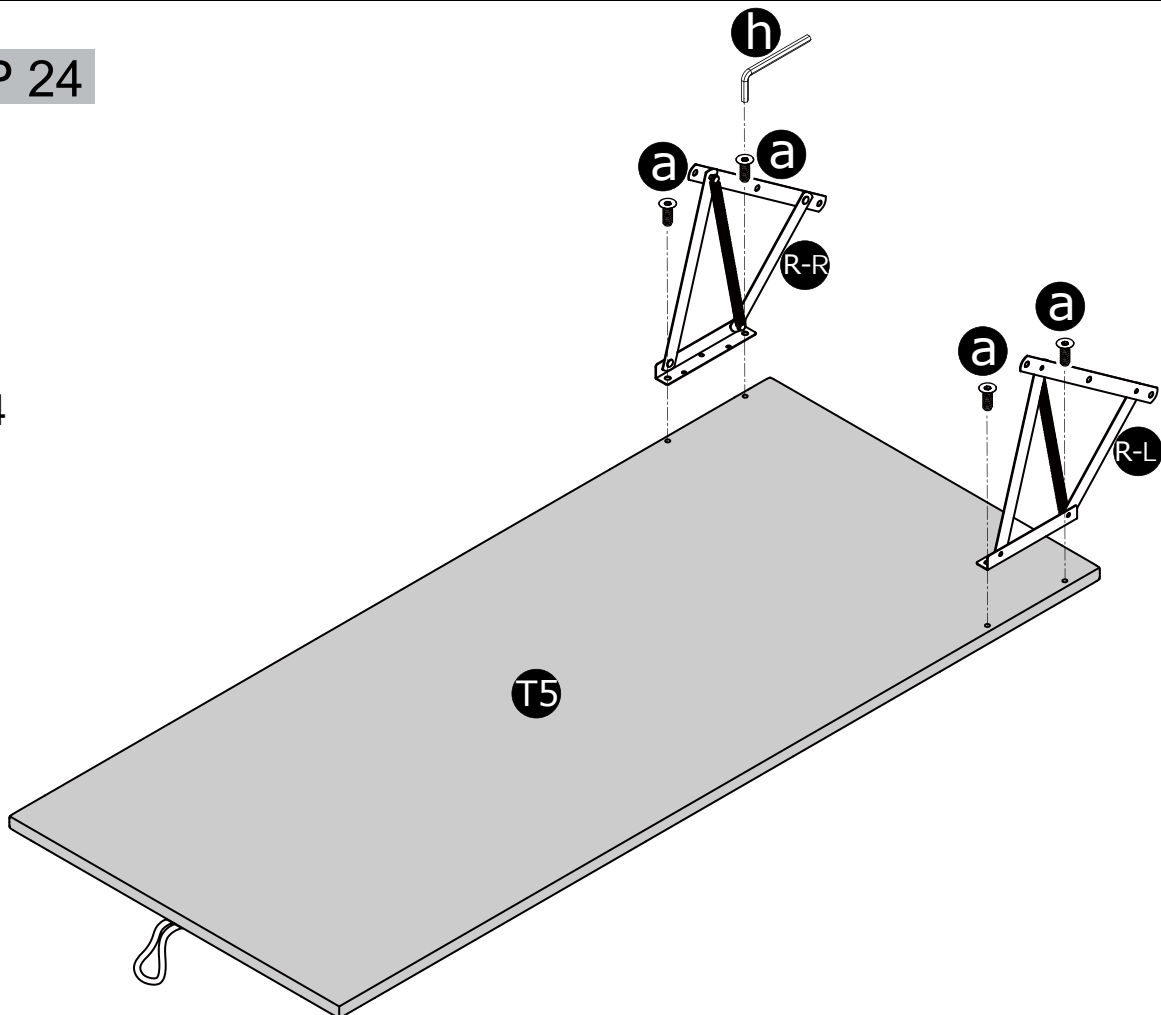

## STEP 25

**a** x6

Insert 3 pieces  
Screws "a"  
separately into both  
side board

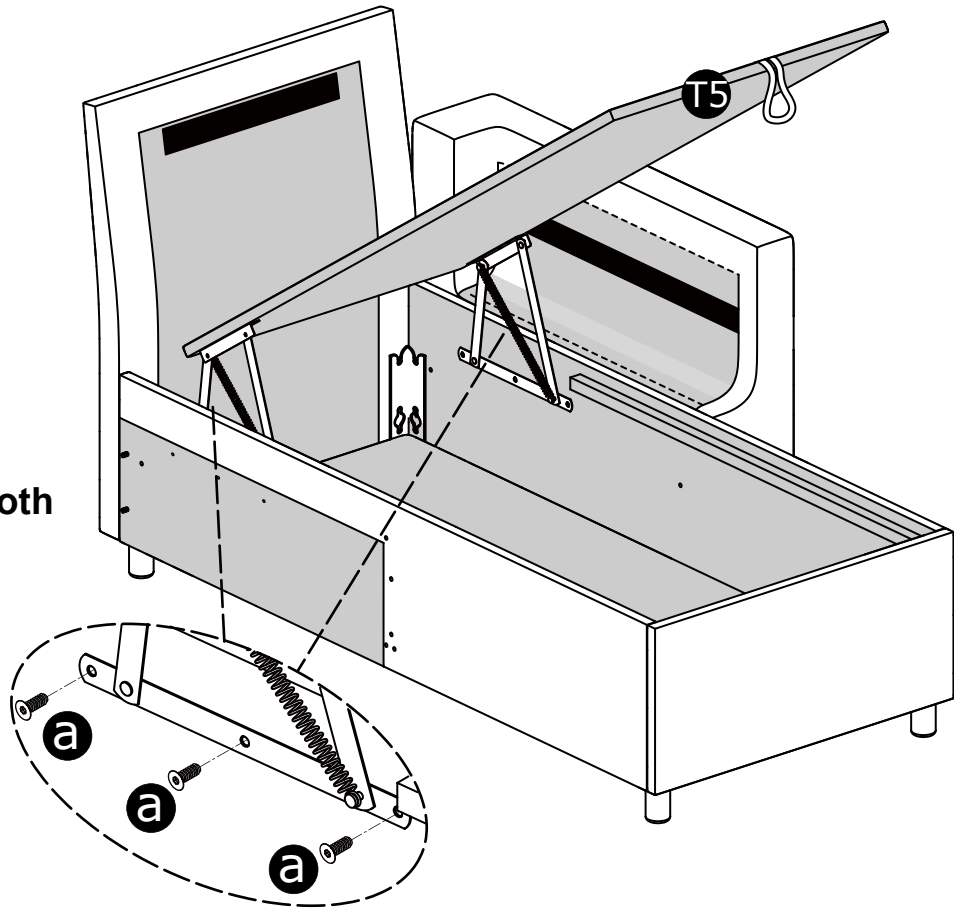

## STEP 26

**V5** x1 **V3** x1

**c** x2 **a** x3

**d** x2 **h** x1

**f** x1

**!** Insert the screws, but do  
not tighten them fully at  
this time.

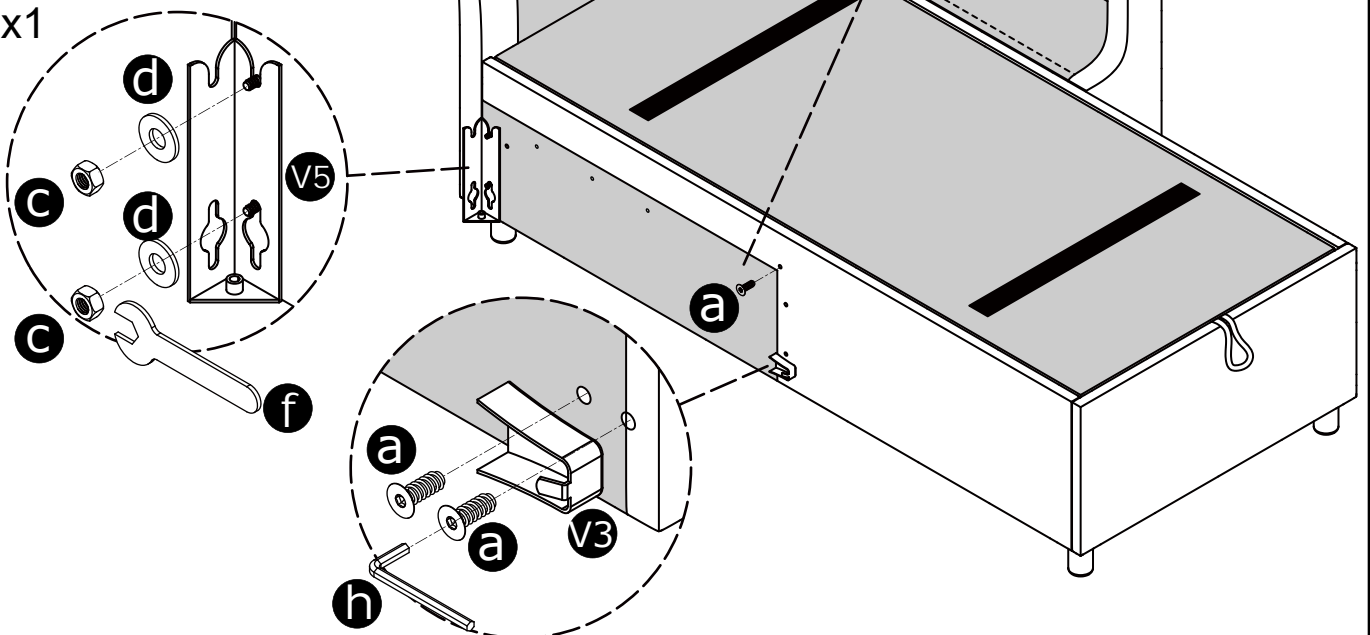

## STEP 27

**a** x7

**h** x1

**!** Insert the screws, but do not tighten them fully at this time.

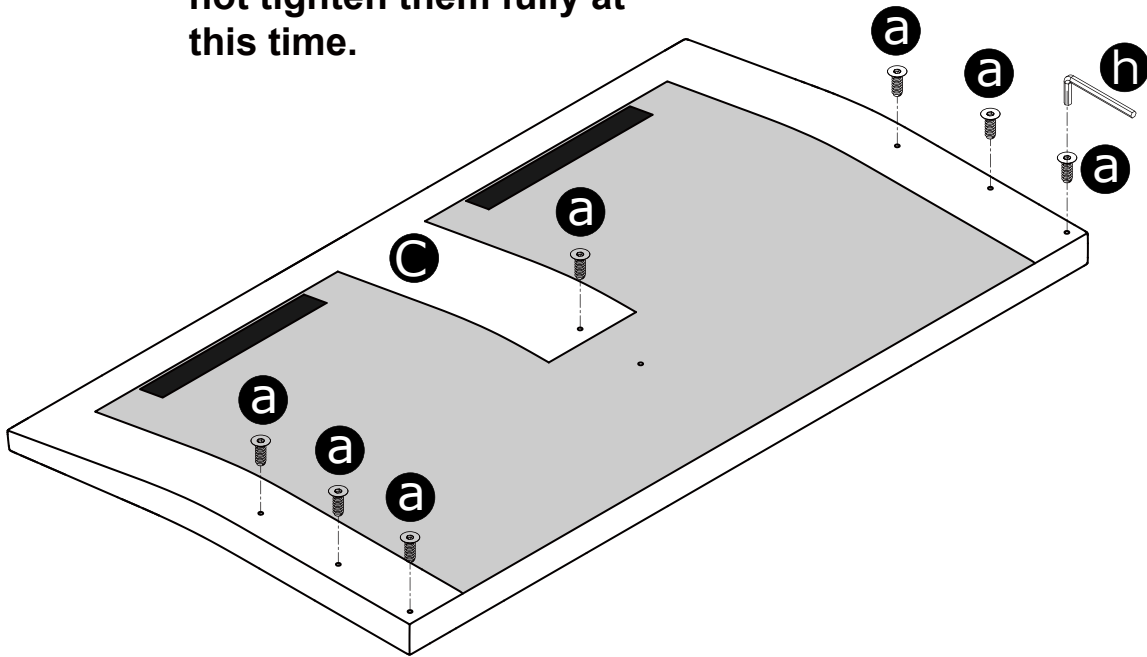

## STEP 28

**!** Slide the screws "a" into part "P" and tighten them at this time

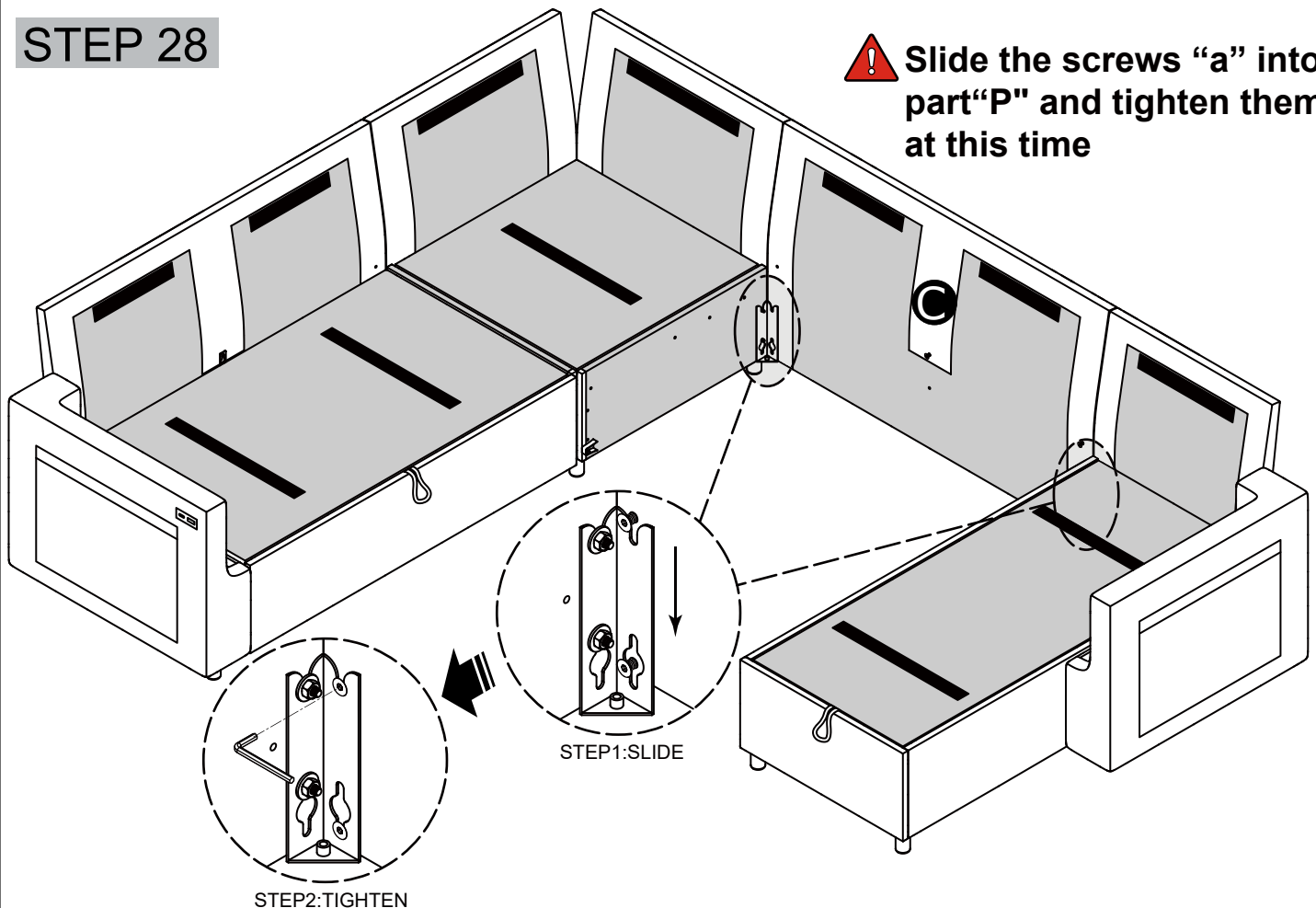

# STEP 29

- a** x5
- h** x1
- V1** x5
- T2** x1

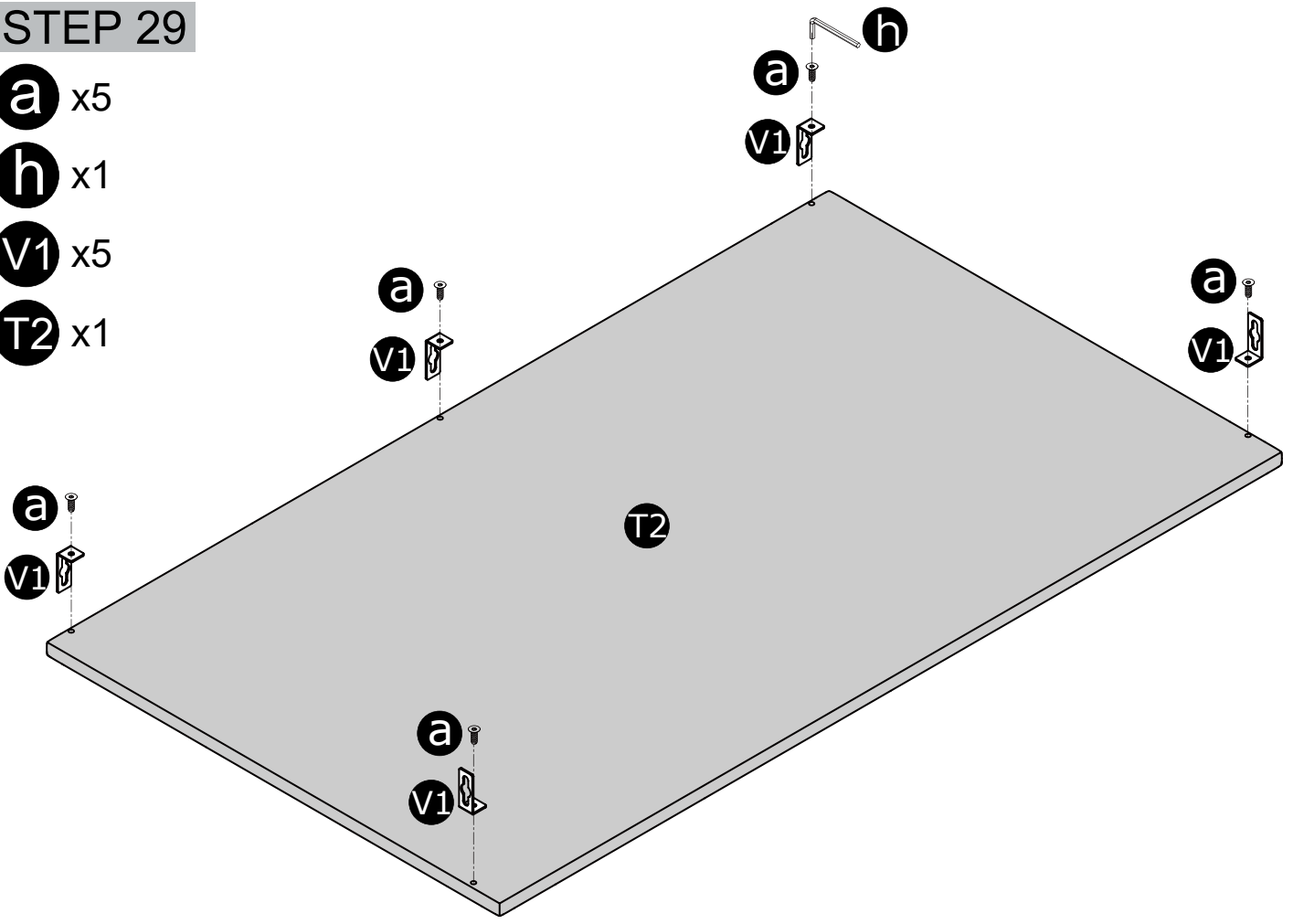

# STEP 30

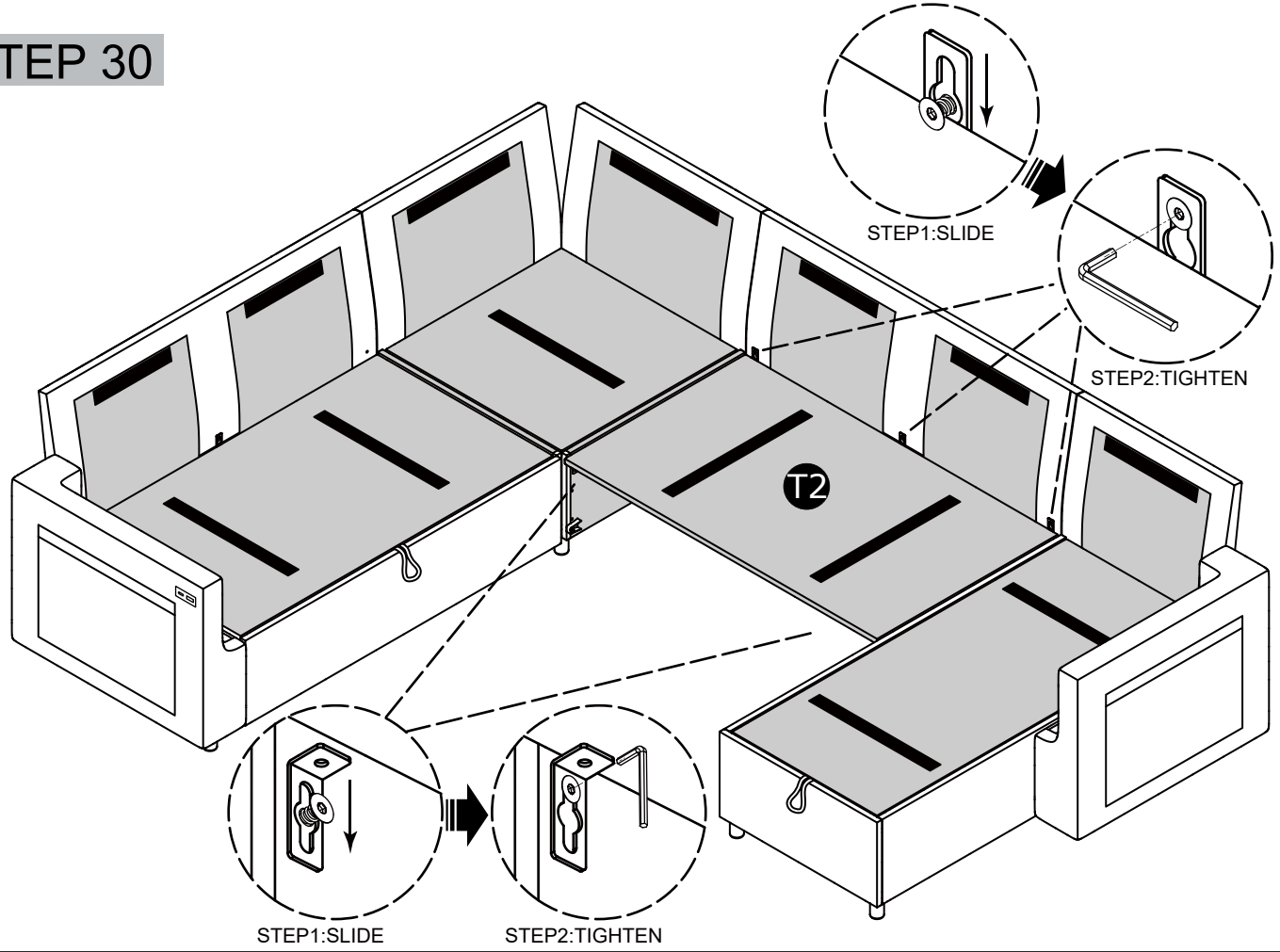

### STEP 31

**e** x4

**Y** x1

**Z** x1

**V4** x2

**g** x1

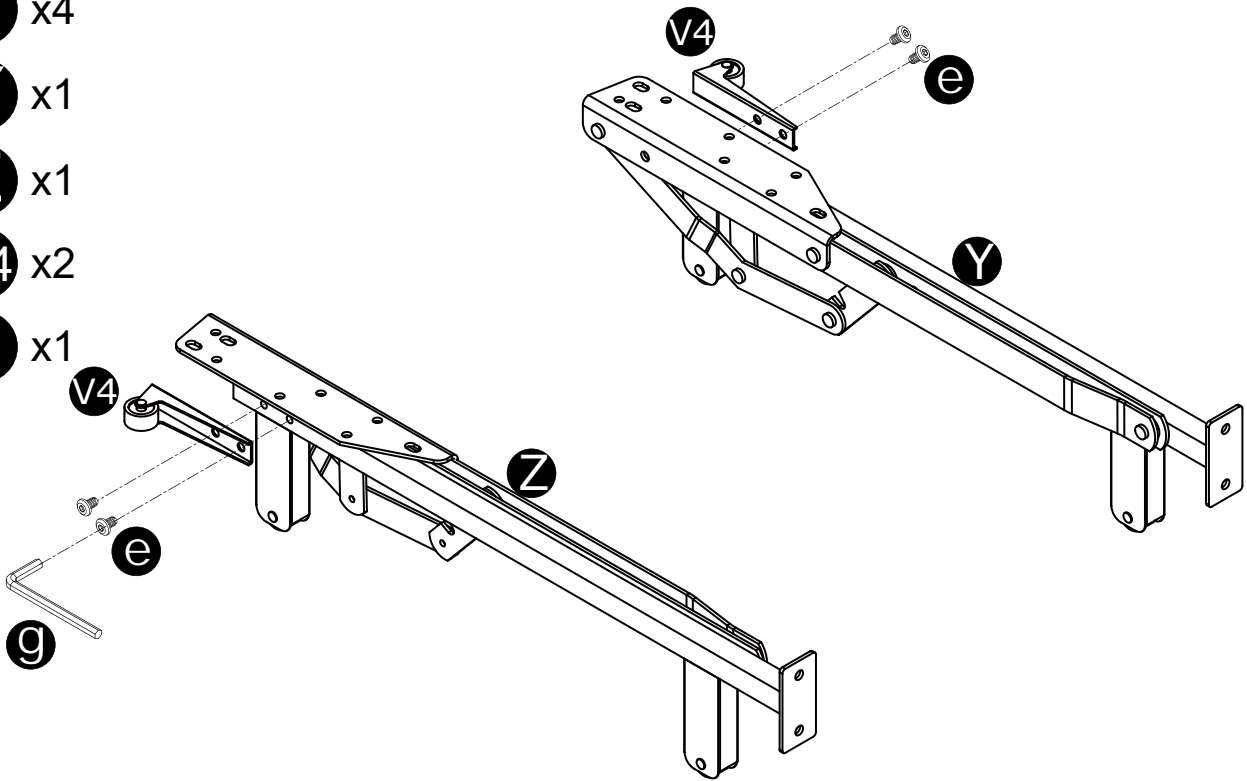

### STEP 32

**a** x4

**J** x1

**d** x2

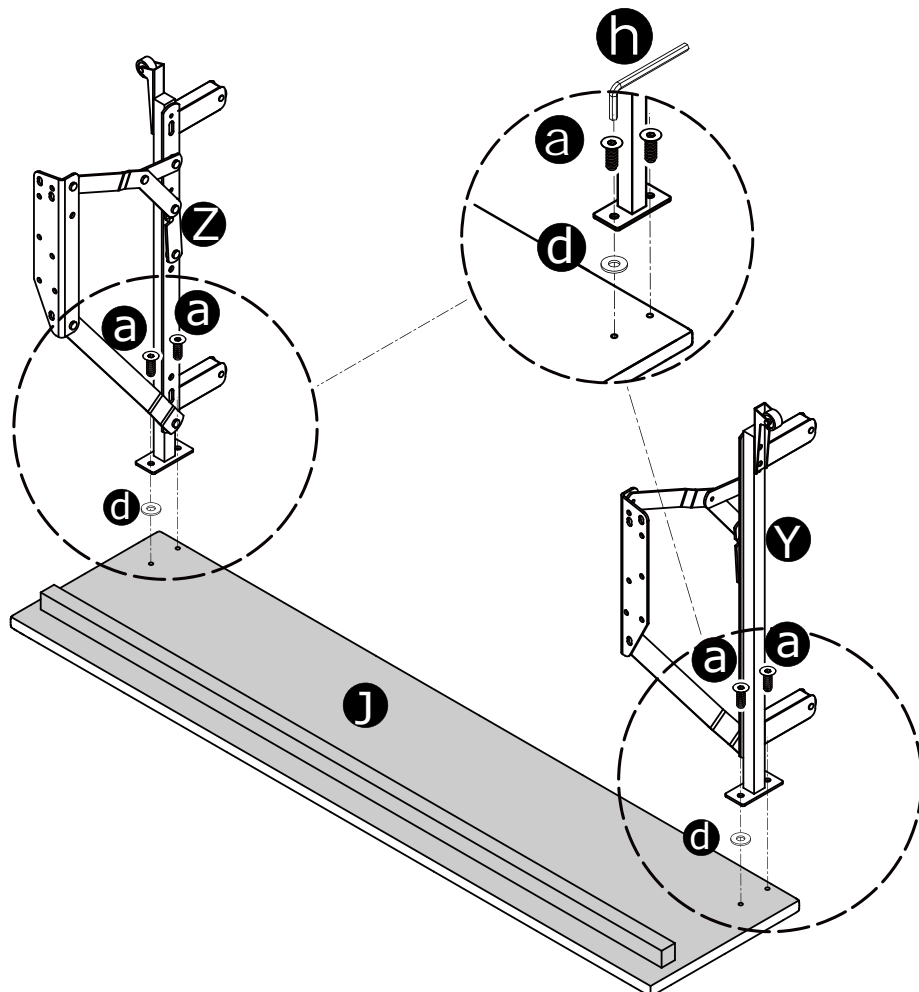

### STEP 33

**a** x4

**T3** x1

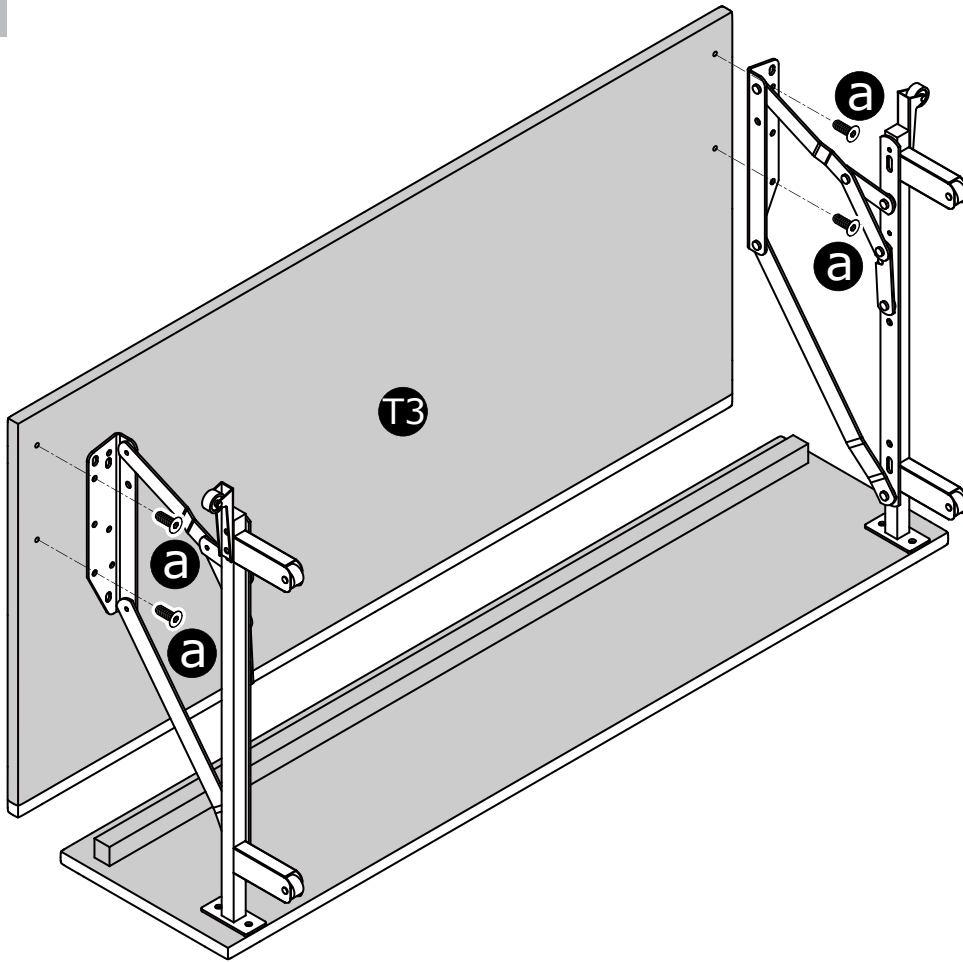

### STEP 34

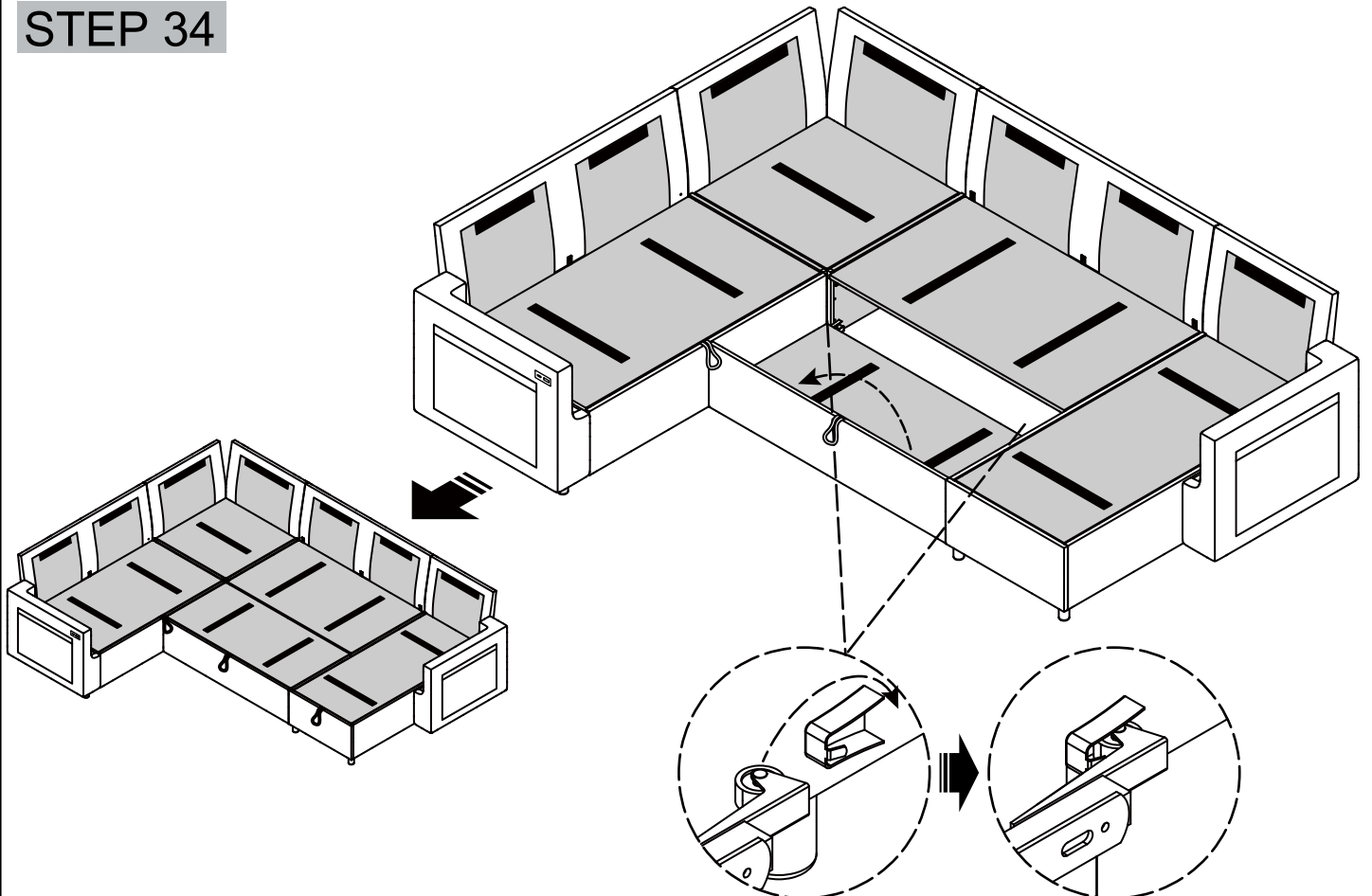

## STEP 35

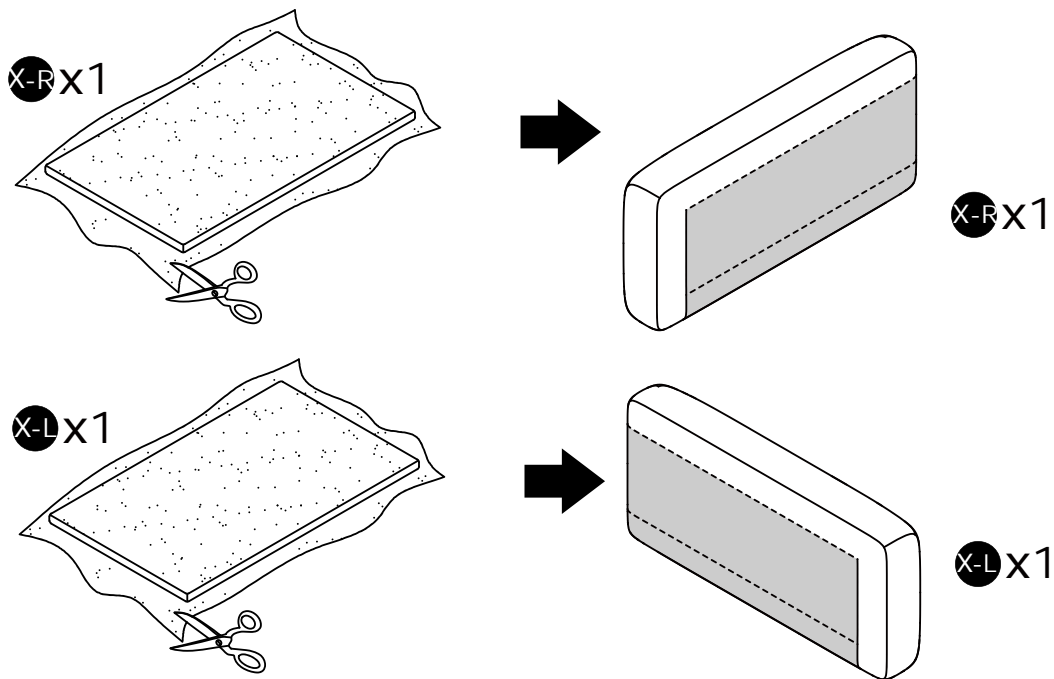

The product is compression parts,  
Please pat them by hand and wait 72 hours, the cushions will be recover.

## STEP 36

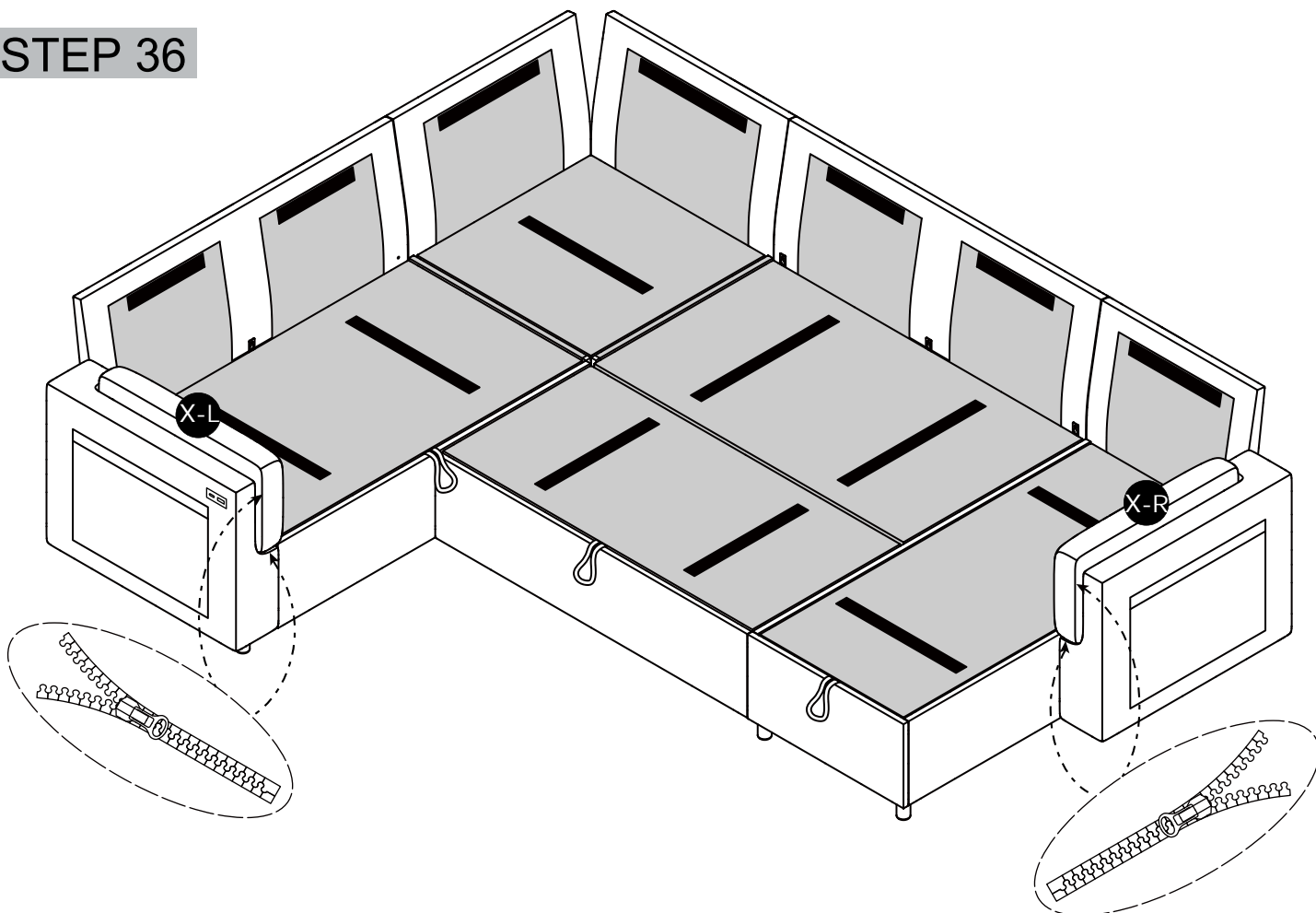

## STEP 35

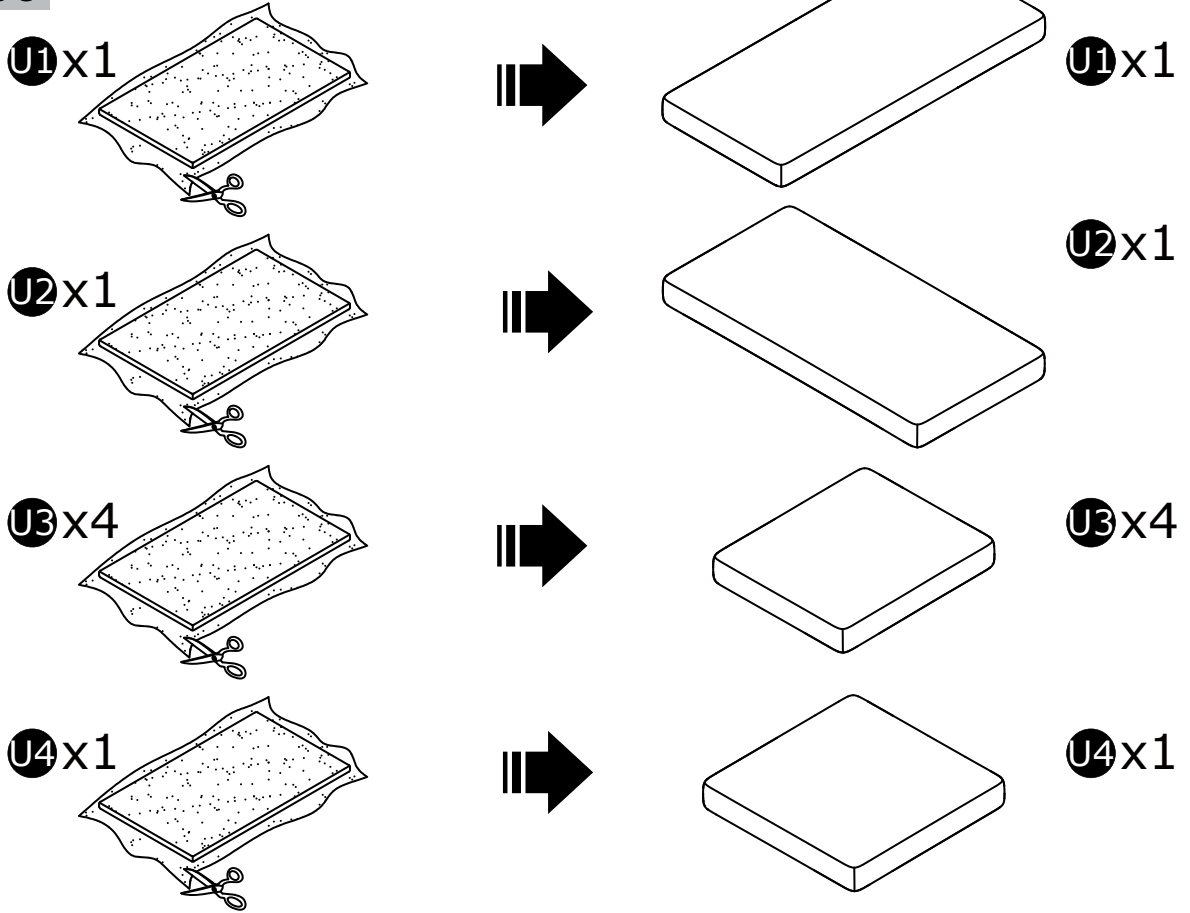

The product is compression parts,  
Please pat them by hand and wait 72 hours, the cushions will be recover.

## STEP 36

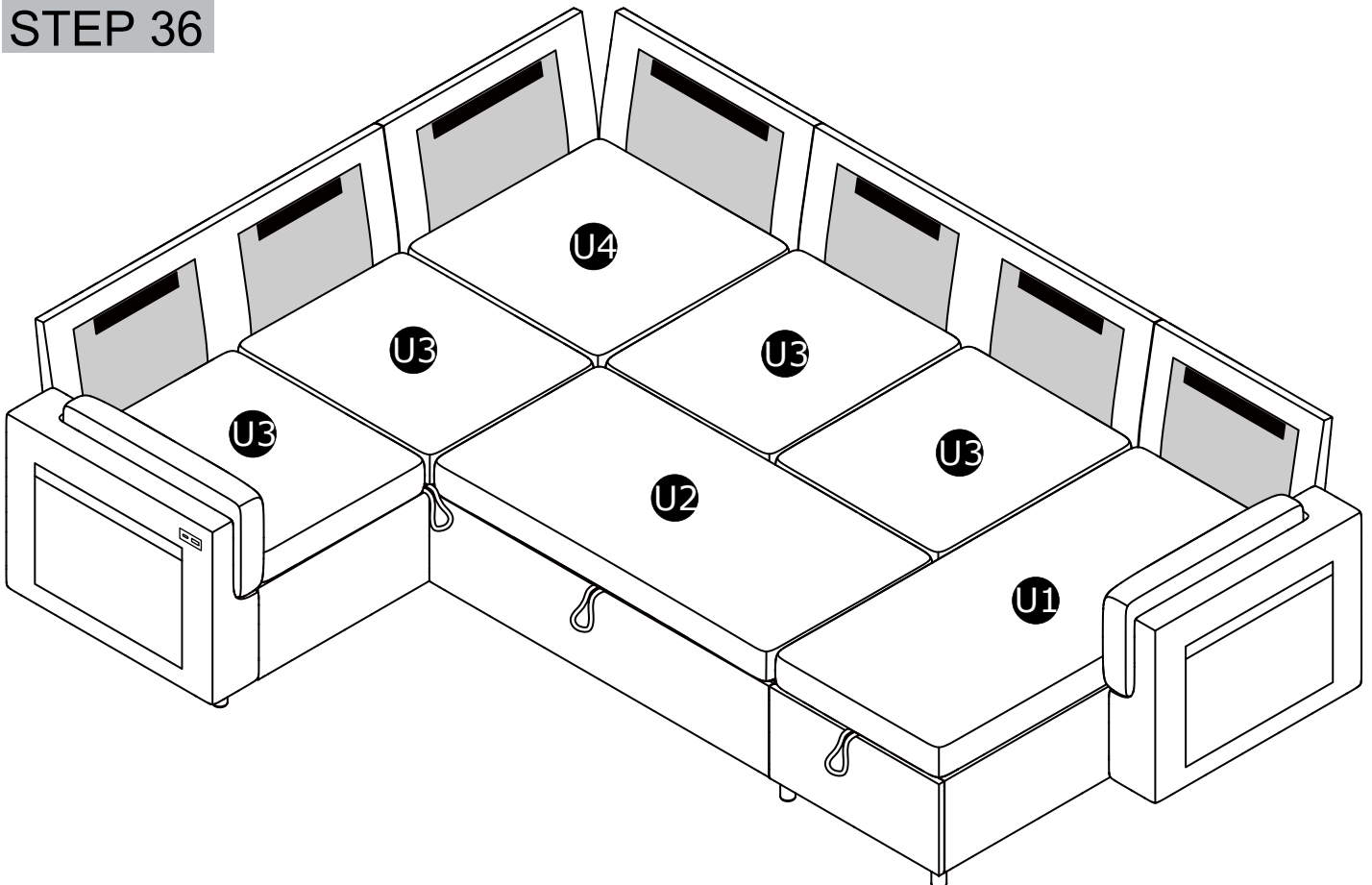

## STEP 37

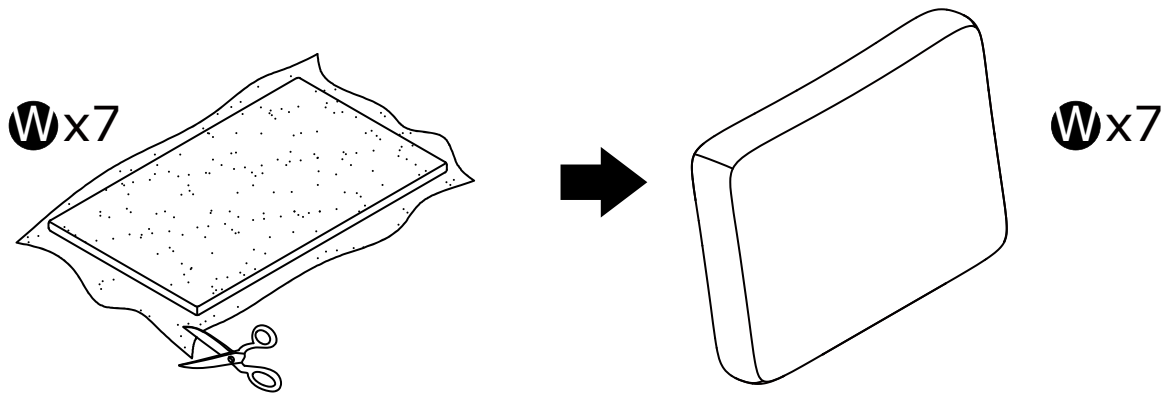

The product is compression parts,  
Please pat them by hand and wait 72 hours, the cushions will be recover.

## STEP 38

