

DE:Installations anleitung
UK:Installation Instruction
FR:Instruction d'installation
IT:Istruzioni di installazione
ES: Instrucciones de instalación
NL: Installatie-instructies
SE: Installationsanvisningar
PL: Instrukcje instalacji

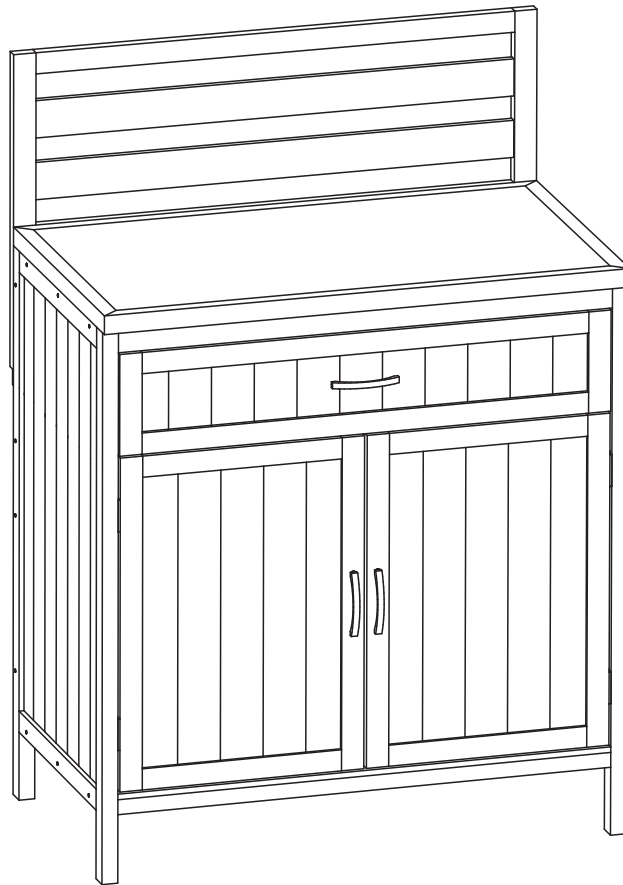

N620P392924N



FR

**Pensez à
donner ou recycler.**



Association

ou



Magasin

ou



Déchèterie

<https://quefairedemesdechets.fr>

DE

Warnhinweise:

1. Überschreiten Sie nicht die maximale Traglast. Stellen Sie keine schweren Gegenstände darauf und vermeiden Sie das Stehen oder Springen auf dem Schrank, um Einsturz oder strukturelle Schäden zu verhindern.
2. Verwenden Sie zur Reinigung ein neutrales Reinigungsmittel und ein weiches Tuch. Keine starken Säuren, Laugen oder Scheuermittel verwenden, um Korrosion oder Beschädigung der Schutzbeschichtung zu vermeiden.
3. Montieren Sie das Produkt gemäß der Anleitung korrekt und ziehen Sie alle Verbindungselemente fest. Beim Bewegen sollten zwei Personen den Schrank gleichmäßig anheben – nicht ziehen oder schieben.
4. Halten Sie den Schrank von offenen Flammen (z. B. Grill) und Wärmequellen fern. Der Sicherheitsabstand sollte mindestens 1,5 m betragen, um Brandgefahr oder Schadstofffreisetzung zu vermeiden.
5. Überprüfen Sie nach der Montage Scharniere, Schienen und andere Teile. Scharfe Kanten müssen abgedeckt werden. Kinder dürfen das Produkt nur unter Aufsicht benutzen, um Quetschverletzungen zu vermeiden.
6. Bei längerer Nichtbenutzung (z. B. im Winter oder bei Regen) entleeren Sie den Schrank, trocknen Sie ihn ab und decken Sie ihn mit einer wasser- und staubdichten Abdeckung ab oder lagern Sie ihn im Innenbereich.

UK

Warnings:

1. Do not exceed the maximum load capacity. Do not stand or jump on the cabinet top to avoid collapse or structural damage.
2. Clean with a neutral detergent and a soft cloth. Do not use strong acids, alkalis, or abrasive products to prevent surface corrosion or damage to the waterproof coating.
3. Assemble the product correctly according to the manual and ensure all fittings are tightened. When moving, lift the cabinet steadily with two people – do not drag or pull.
4. Keep the cabinet away from open flames (such as BBQ grills) and heat sources. Maintain a minimum safety distance of 1.5 m to prevent fire or release of harmful substances.
5. After assembly, check hinges, slides, and other components. Cover sharp edges. Children must use the cabinet under adult supervision to avoid finger injuries.
6. When not in use for a long time (e.g. during winter or rainy seasons), empty the cabinet, dry it, and cover it with a waterproof and dustproof cover or store it indoors.

FR

Avertissements :

1. Ne dépassez pas la charge maximale. Ne montez pas et ne sautez pas sur le dessus du meuble afin d'éviter tout effondrement ou dommage structurel.
2. Nettoyez avec un détergent neutre et un chiffon doux. N'utilisez pas de produits acides, alcalins ou abrasifs pour éviter la corrosion ou la détérioration du revêtement protecteur.
3. Assemblez correctement selon le manuel et serrez toutes les fixations. Lors du déplacement, soulevez le meuble à deux personnes – ne le tirez pas.
4. Tenez le meuble éloigné des flammes nues (comme un barbecue) et des sources de chaleur. Maintenez une distance de sécurité d'au moins 1,5 m pour éviter tout risque d'incendie ou d'émission de substances nocives.
5. Après montage, vérifiez les charnières, les rails et autres pièces. Protégez les bords tranchants. Les enfants doivent l'utiliser sous la surveillance d'un adulte pour éviter de se pincer les doigts.
6. En cas de non-utilisation prolongée (hiver/pluie), videz le meuble, séchez-le et couvrez-le avec une housse imperméable et anti-poussière ou rangez-le à l'intérieur.

IT

Avvertenze:

1. Non superare il carico massimo consentito. Non salire né saltare sulla parte superiore del mobile per evitare il crollo o danni strutturali.
2. Pulire con un detergente neutro e un panno morbido. Non utilizzare prodotti acidi, alcalini o abrasivi per evitare corrosione o danni al rivestimento protettivo.
3. Assemblare correttamente seguendo il manuale e serrare bene tutti i collegamenti. Durante lo spostamento, sollevare il mobile in due persone – non trascinare.
4. Tenere il mobile lontano da fiamme libere (ad esempio barbecue) e da fonti di calore. Mantenere una distanza di sicurezza di almeno 1,5 m per evitare incendi o emissioni di sostanze nocive.
5. Dopo il montaggio, controllare cerniere, guide e altri componenti. Coprire le parti taglienti. I bambini devono usarlo sotto la supervisione di un adulto per evitare schiacciamenti alle dita.
6. Se non utilizzato per lungo tempo (ad esempio in inverno o stagione delle piogge), svuotare il mobile, asciugarlo e coprirlo con un telo impermeabile e antipolvere o conservarlo all'interno.

ES

Advertencias:

1. No exceda la carga máxima. No se suba ni salte sobre la parte superior del armario para evitar colapsos o daños estructurales.
2. Limpie con un detergente neutro y un paño suave. No utilice productos ácidos, alcalinos ni abrasivos para evitar la corrosión o daños en el revestimiento protector.
3. Ensamble correctamente según el manual y asegúrese de que todas las piezas estén bien ajustadas. Al moverlo, dos personas deben levantarlo con cuidado; no arrastre el armario.
4. Mantenga el armario alejado de llamas abiertas (por ejemplo, parrillas) y fuentes de calor. Guarde una distancia de seguridad mínima de 1,5 m para evitar incendios o emisiones nocivas.
5. Tras el montaje, revise las bisagras, guías y demás componentes. Cubra las partes afiladas. Los niños deben usarlo bajo supervisión adulta para evitar pellizcos en los dedos.
6. Si no se usa durante mucho tiempo (invierno o temporada de lluvias), vacíe el armario, séquelo y cúbralo con una funda impermeable y antipolvo o guárdelo en interiores.

NL

Waarschuwingen:

1. Overschrijd de maximale belasting niet. Ga niet op de kast staan of springen om instorting of structurele schade te voorkomen.
2. Reinig met een neutraal schoonmaakmiddel en een zachte doek. Gebruik geen sterke zuren, basen of schuurmiddelen om corrosie of schade aan de beschermlaag te voorkomen.
3. Monteer volgens de handleiding en draai alle bevestigingen stevig vast. Til de kast met twee personen – niet slepen.
4. Houd de kast uit de buurt van open vuur (zoals barbecues) en warmtebronnen. Houd minimaal 1,5 m afstand om brand of schadelijke dampen te voorkomen.
5. Controleer na montage de scharnieren, geleiders en andere onderdelen. Bedek scherpe randen. Kinderen mogen de kast alleen onder toezicht gebruiken om beknelling te voorkomen.
6. Bij langdurige opslag (winter of regenseizoen): maak de kast leeg, droog hem af en bedek hem met een water- en stofdichte hoes of bewaar binnenshuis.

SE

Varningar:

1. Överskrid inte den maximala belastningen. Stå eller hoppa inte på skåpet för att undvika kollaps eller strukturskador.
2. Rengör med ett neutralt rengöringsmedel och en mjuk trasa. Använd inte starka syror, baser eller slipmedel som kan skada ytan eller skyddsbeläggningen.
3. Montera enligt instruktionerna och dra åt alla fästen ordentligt. När du flyttar möbelen ska två personer lyfta den försiktigt – dra inte.
4. Håll skåpet borta från öppen eld (t.ex. grillar) och värmekällor. Håll ett säkerhetsavstånd på minst 1,5 m för att undvika brand eller utsläpp av skadliga ämnen.
5. Kontrollera gångjärn, skenor och andra delar efter montering. Täck vassa kanter. Barn ska använda skåpet under vuxens tillsyn för att undvika klämskador.
6. Vid längre förvaring (vinter/regnperiod), töm skåpet, torka det torrt och täck det med ett vattentätt och dammtätt skydd eller förvara det inomhus.







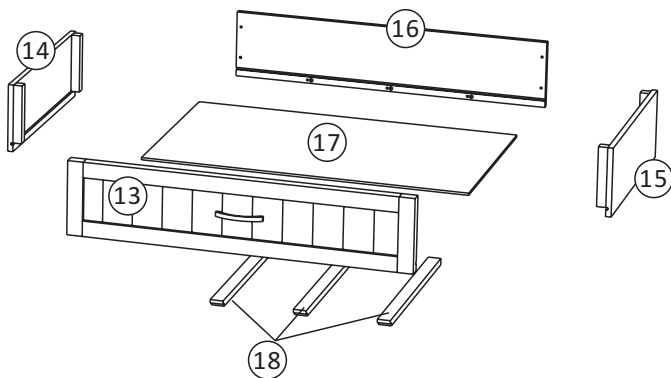
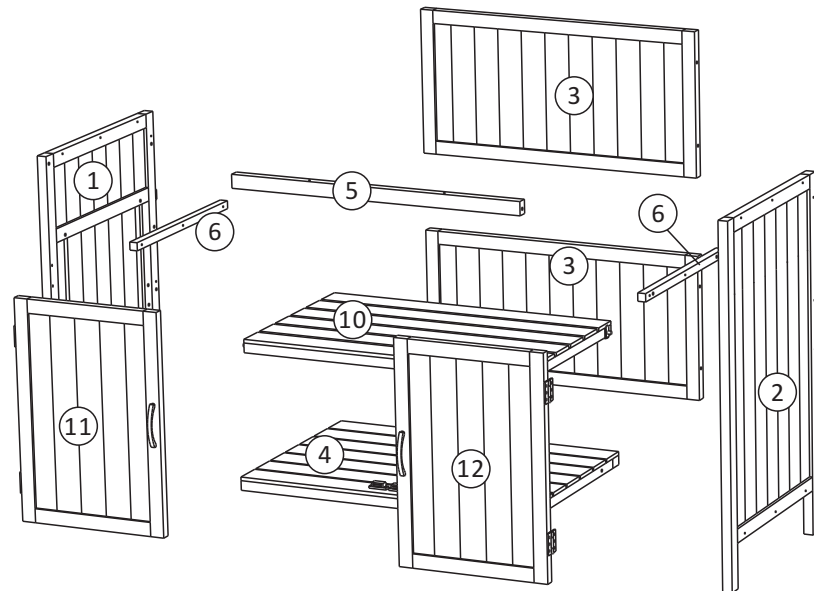
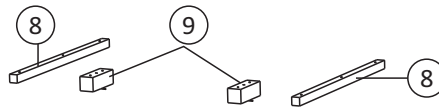
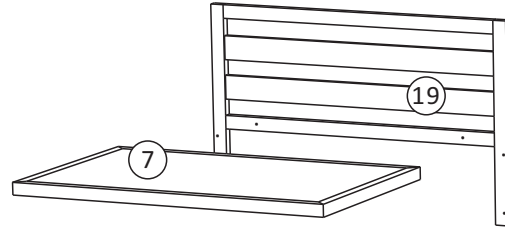



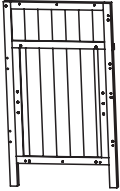

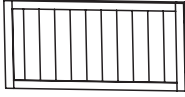
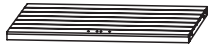



PL

Ostrzeżenia:

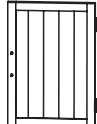
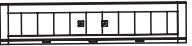





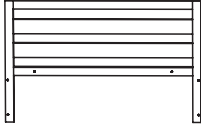





1. Nie przekraczaj maksymalnego obciążenia. Nie stawaj ani nie skacz na szafce, aby uniknąć zawalenia lub uszkodzenia konstrukcji.
2. Czyść neutralnym detergentem i miękką ściereczką. Nie używaj silnych kwasów, zasad ani środków ściernych, aby uniknąć korozji lub uszkodzenia powłoki ochronnej.
3. Zmontuj produkt zgodnie z instrukcją i dokręć wszystkie elementy. Podczas przenoszenia dwie osoby powinny ostrożnie podnieść szafkę – nie ciągnij jej.
4. Trzymaj szafkę z dala od otwartego ognia (np. grilla) i źródeł ciepła. Zachowaj bezpieczną odległość co najmniej 1,5 m, aby zapobiec pożarom lub emisji szkodliwych substancji.
5. Po montażu sprawdź zawiasy, prowadnice i inne elementy. Owiń ostre krawędzie. Dzieci powinny korzystać z mebla wyłącznie pod opieką dorosłych, aby uniknąć przytraśnięcia palców.
6. Podczas długotrwałego nieużywania (zimą lub w porze deszczowej) opróżnij szafkę, wysusz ją i przykryj wodoodpornym i przeciwkurzowym pokrowcem lub przechowuj wewnątrz.



N620P392924N

1		2		3		4	
	1x		1x		2x		1x
5		6		7		8	
	1x		2x		1x		2x
9		10		11		12	
	2x		1x		1x		1x
13		14		15		16	
	1x		1x		1x		1x
17		18		19			
	1x		3x		1x		

Hardware List

A	 Ø 3.5*60 2x	B	 Ø 3.5*50 18x	C	 Ø 3.5*40 22x	D	 Ø 3.0*30 10x
E	 Ø 3.0*16 18x	F	 Ø 3.0*35 6x	G	 21x	H	 1x
I	 2x	J	 2x	K	 2x	L	 4x
M	 2x						

ASSEMBLY TOOLS REQUIRED(NOT INCLUDED)



PLEASE BE CAREFUL DO NOT DAMAGE THE HOLE POSITION WHEN YOU USE POWERTOOLS !

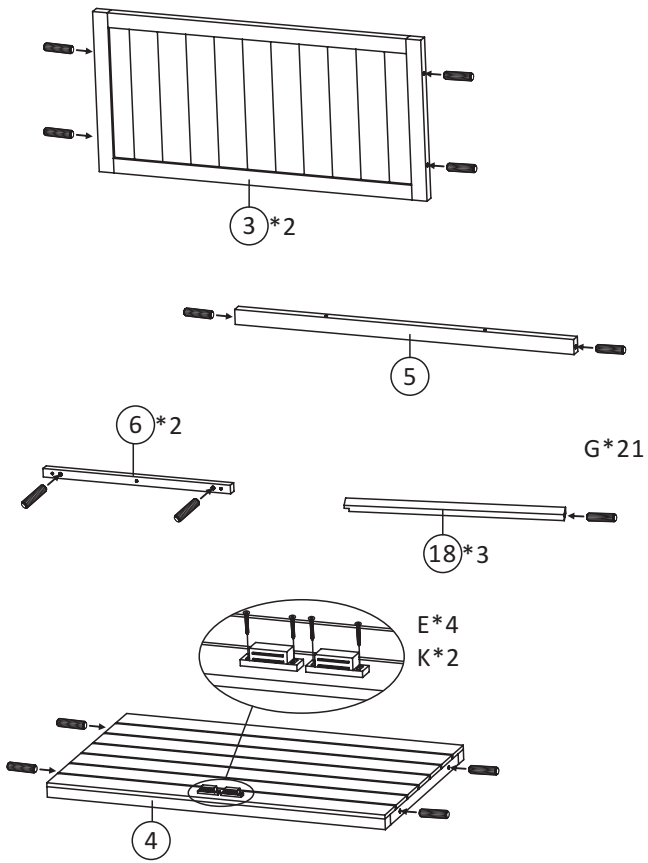

1	3.0*16MM		
	E*4	G*21	K*2

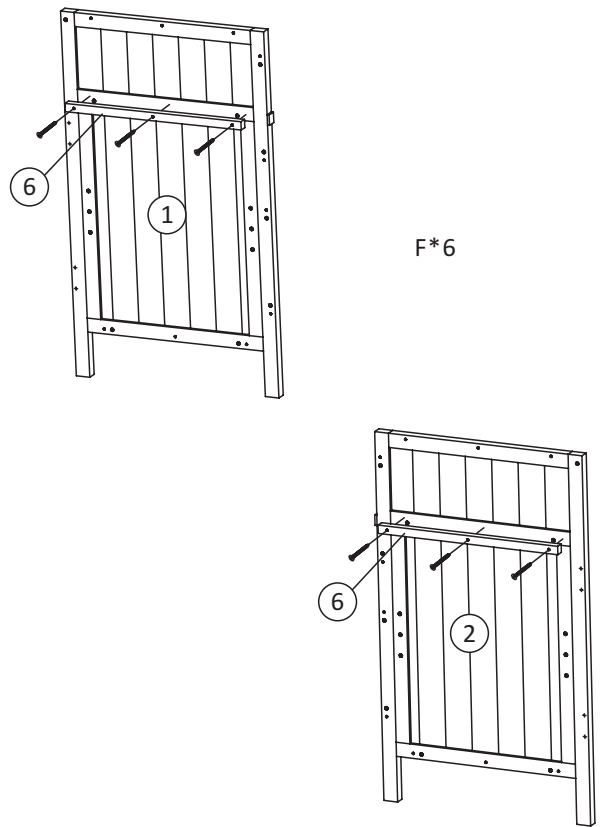

2	3.0*35MM
	F*6

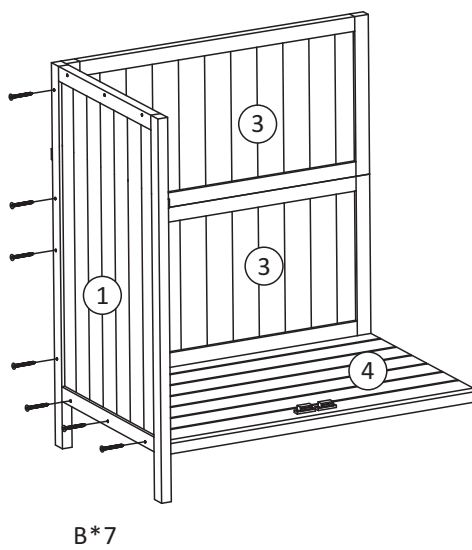

3	3.5*50MM
	B*7

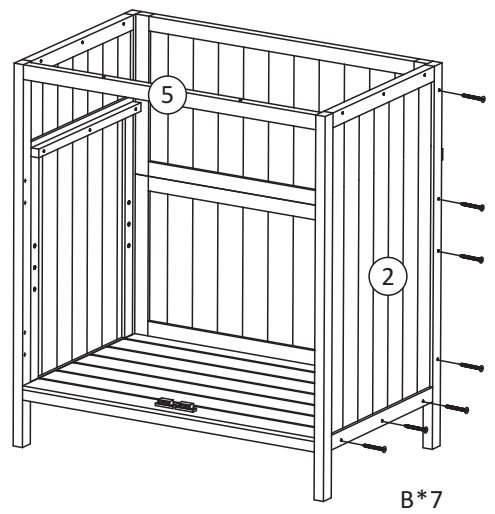

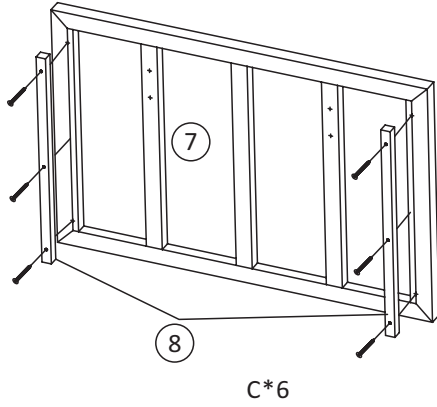

4	3.5*50MM
	B*7

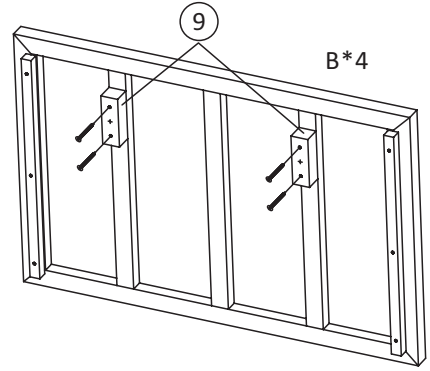

 3.5*40MM
C*6

5



 3.5*50MM
B*4

6

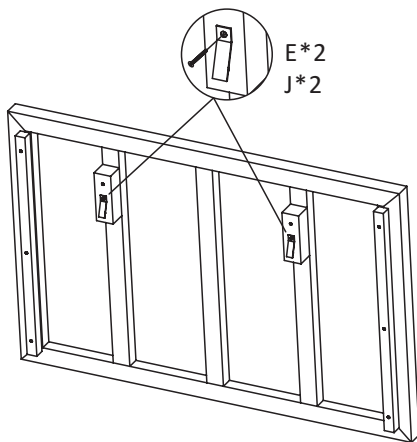



 3.0*16MM
E*2

J*2

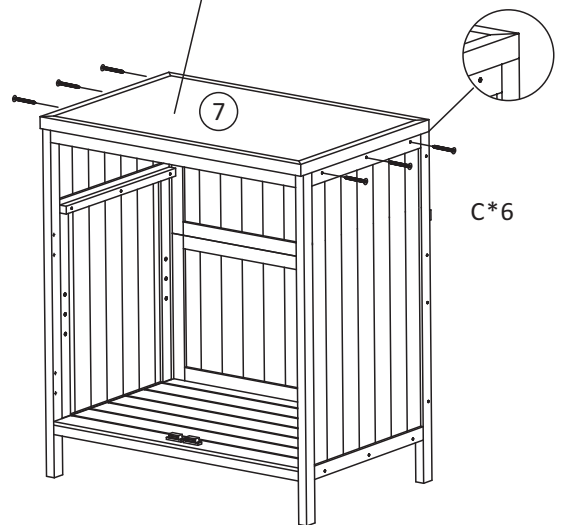
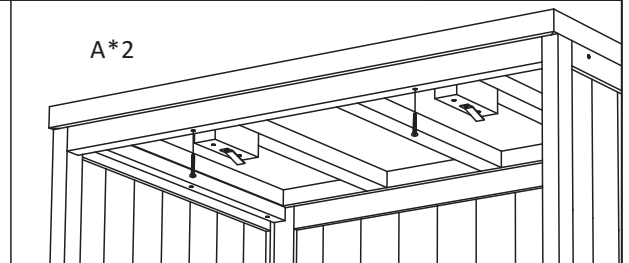
7



 3.5*60MM
A*2

 3.5*40MM
C*6

8

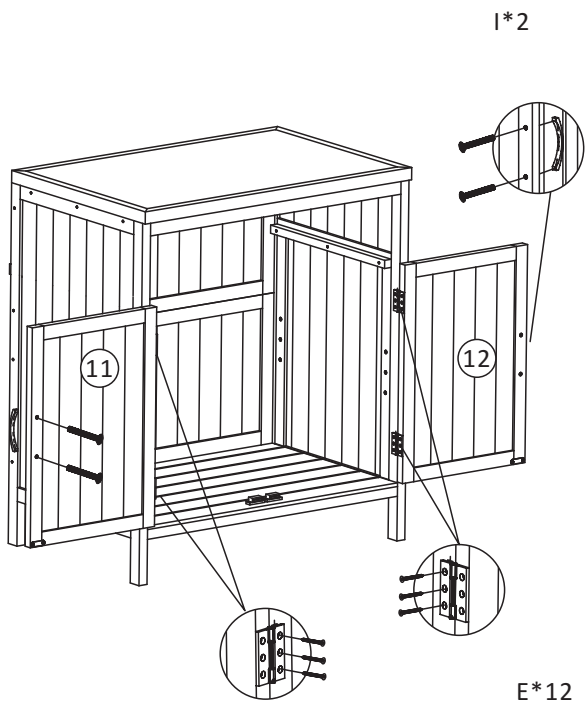

9

 3.0*16MM
E*12

 I*2
I*2

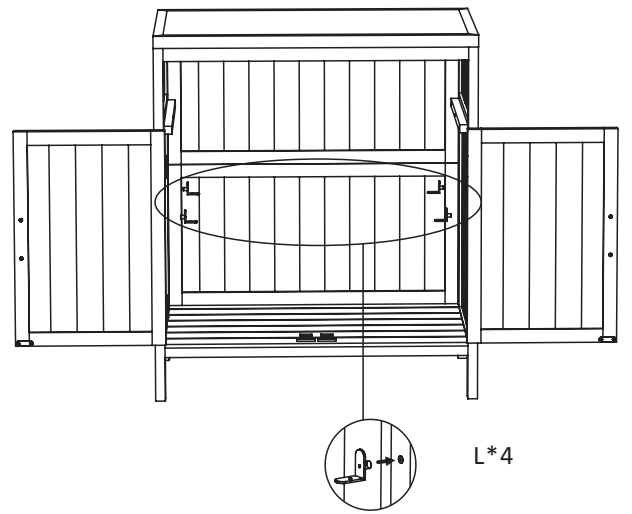

10

 L*4
L*4

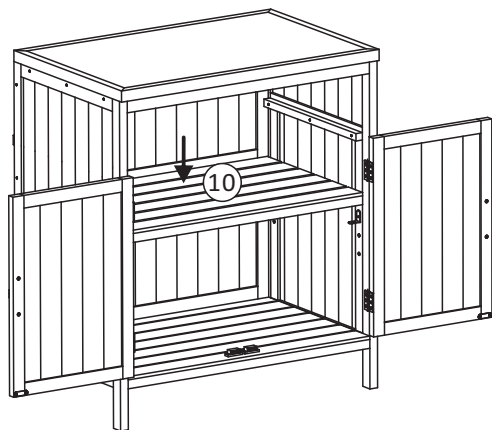

11

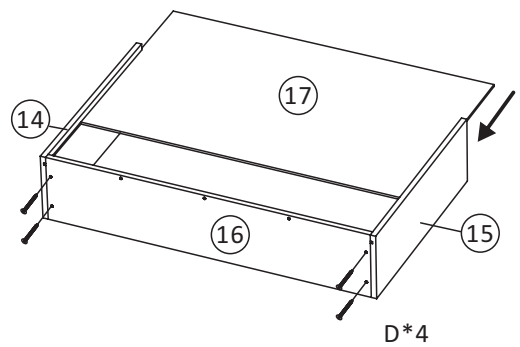

12

 3.0*30MM
D*4

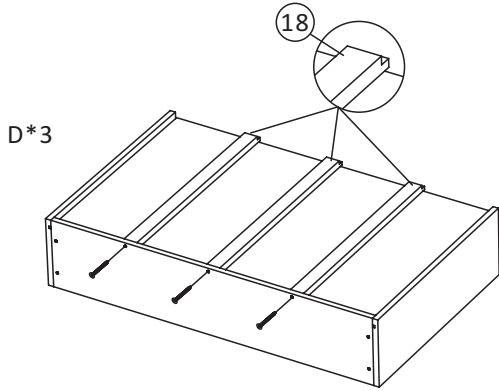

13

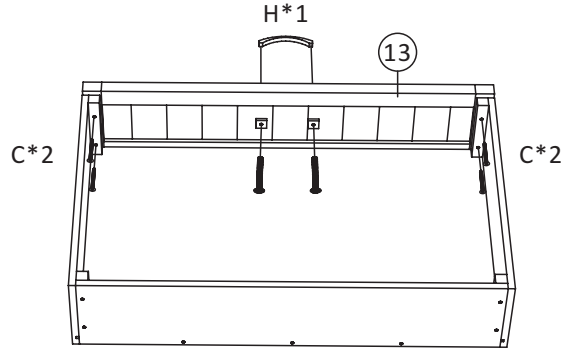
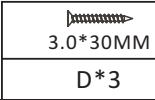

14

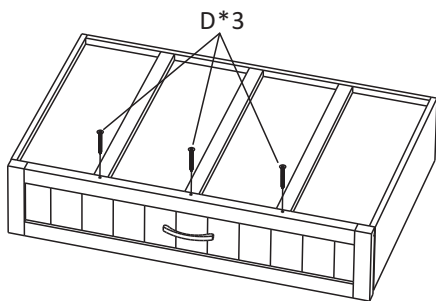
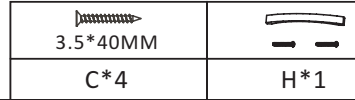

15

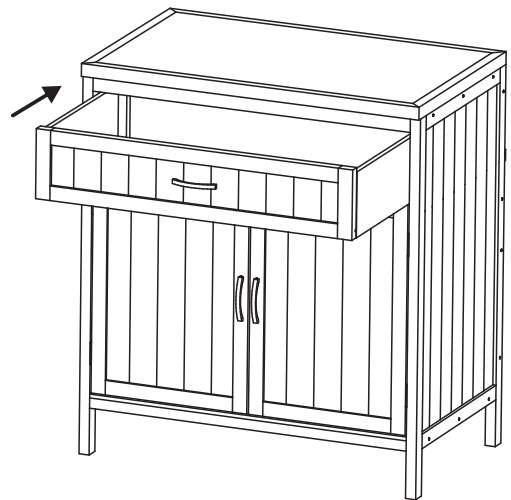
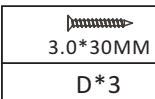

16

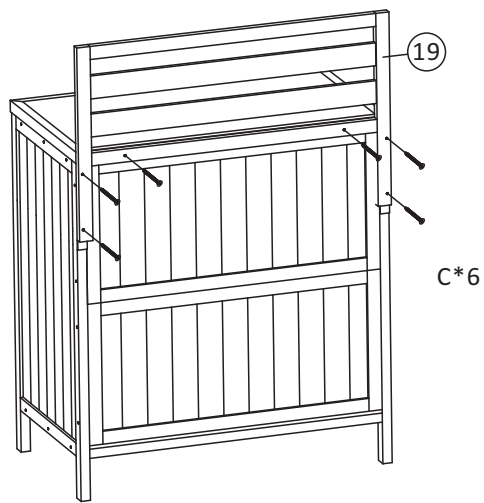

17

3.5*40MM
C*6

WALL

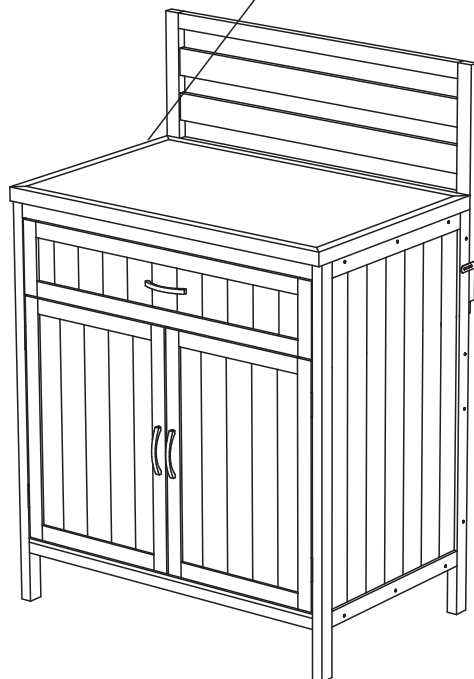
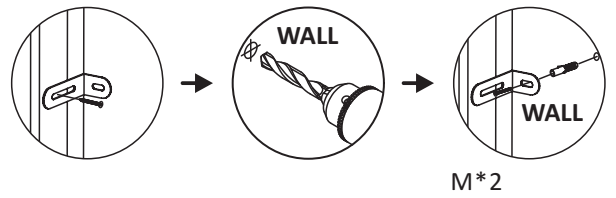

18

M*2