

Bracket A*2

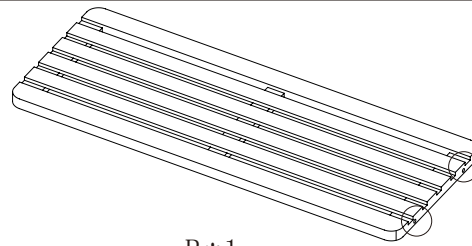

B*1

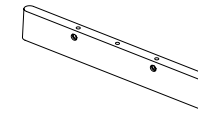

C*2

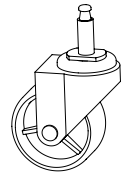

D*4

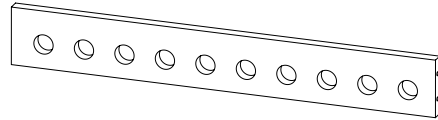

E*1

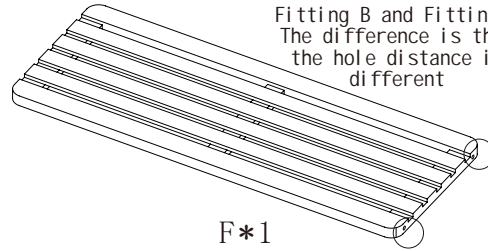

F*1



G*4

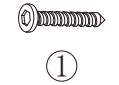

1

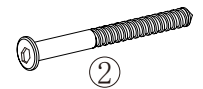

2

1

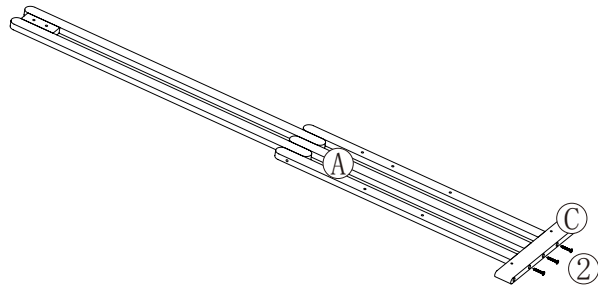

Install accessory A and accessory C with No. 2 screws

2

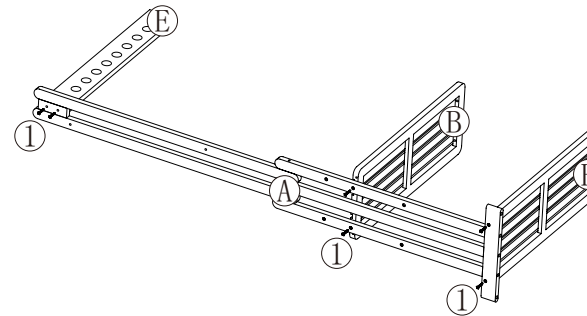

Install accessory E/accessory B/accessory F to accessory A with No. 1 screws

3

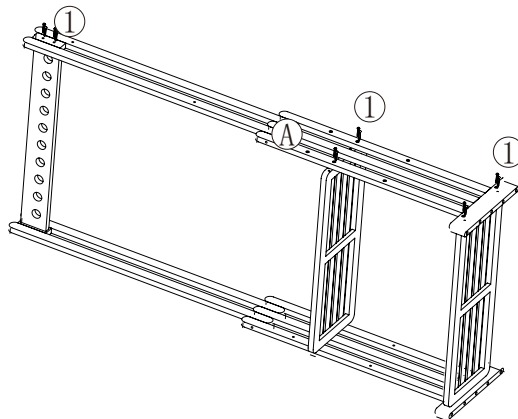

Install the other bracket A with the No. 1 screw

4

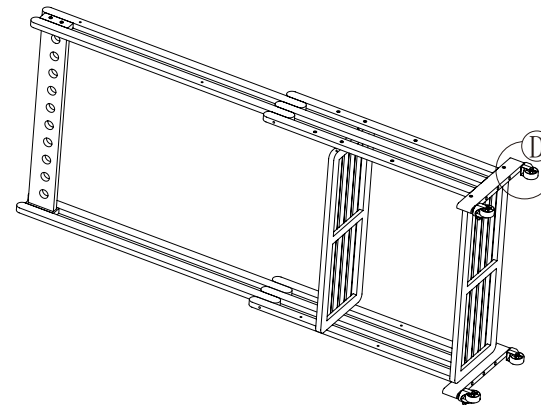

Turn 4 wheels D into the holes of accessory C

5

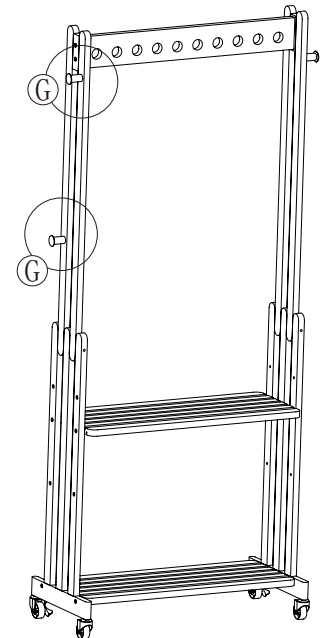

Screw the accessory G to the bracket A and the installation is complete. Screw the accessory G to the bracket A and the installation is complete.