

ASSEMBLY INSTRUCTION BAUANLEITUNG

N729P392155
N729P392156

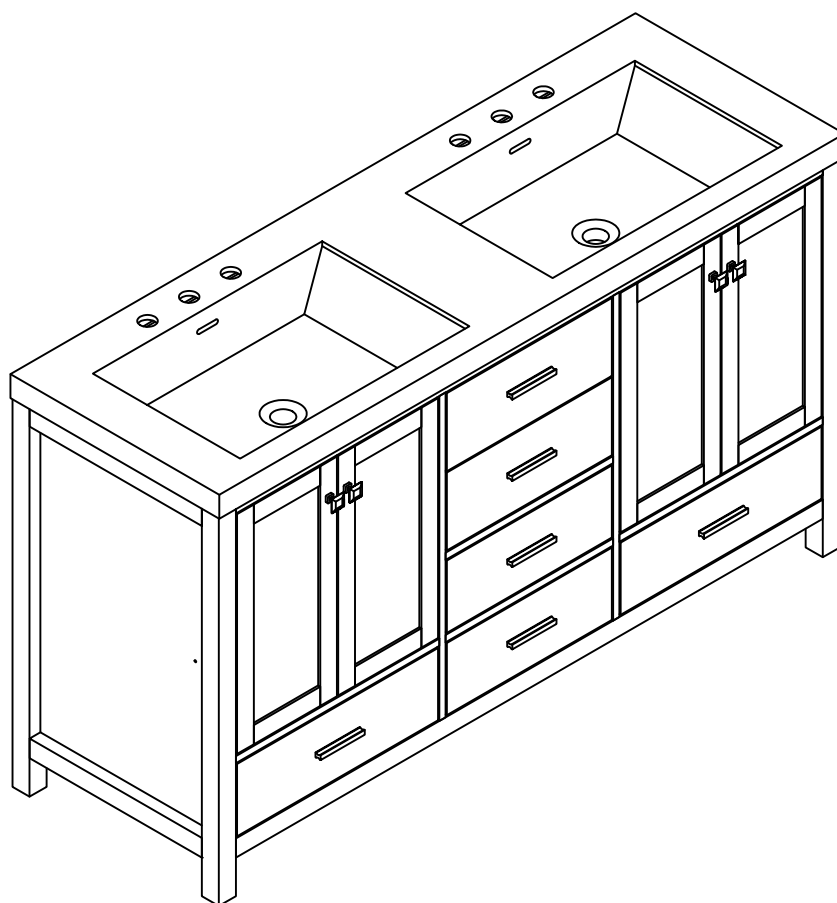

Thank you for purchasing this quality product. Be sure to check all packing materials carefully for small parts, which may have come loose inside the carton during shipment. Identify and count all items according to the PARTS LIST and/or HARDWARE LIST shown below. Check you have all the components and tools listed on the following pages.

- We recommend that you assemble this product with the assistance of another person; this will make the assembly easier, and will help eliminate damage to the product or injury to persons during assembly.
- Please do not over tighten screws or bolts until the assembly is completed.
- Keep children and animal away from the work area, small parts could choke if swallowed. Please put all parts on a non-abrasive floor before assembly, and follow the assembly steps to assemble your newly purchased product correctly and efficiently.

Cam Lock Assembly Instructions

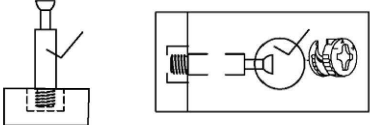
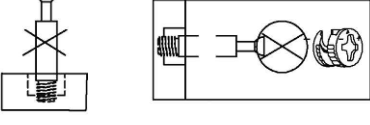
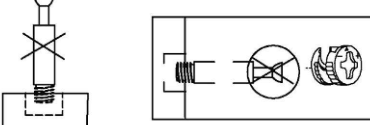
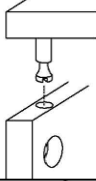
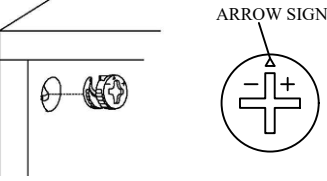
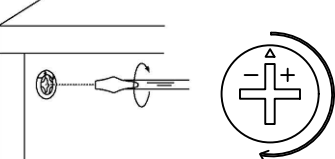
	<p>Diagram A</p> <p>Insert Cam Bolt into hole as shown in diagram A.</p>
	<p>Diagram B</p> <p>Make sure not to insert the Cam Bolt: Too deep as shown in figure B as this will cause the Cam Lock to be misaligned and unable to interlock properly.</p>
	<p>Diagram C</p> <p>Also avoid inserting the Cam Bolt too close to the surface of the hole as shown in figure C, as this will cause the Cam Lock to be too loose, and not interlock properly.</p>
	<p>Connect the panels together.</p>
	<p>Insert the Cam Lock so the side opening fits over the head of the Cam Bolt.</p>
	<p>To tighten the Cam Lock, turn it clockwise on half a turn with a flat screwdriver. *Do not use an automatic screwdriver as it may bend or break if too much power is imposed.</p>

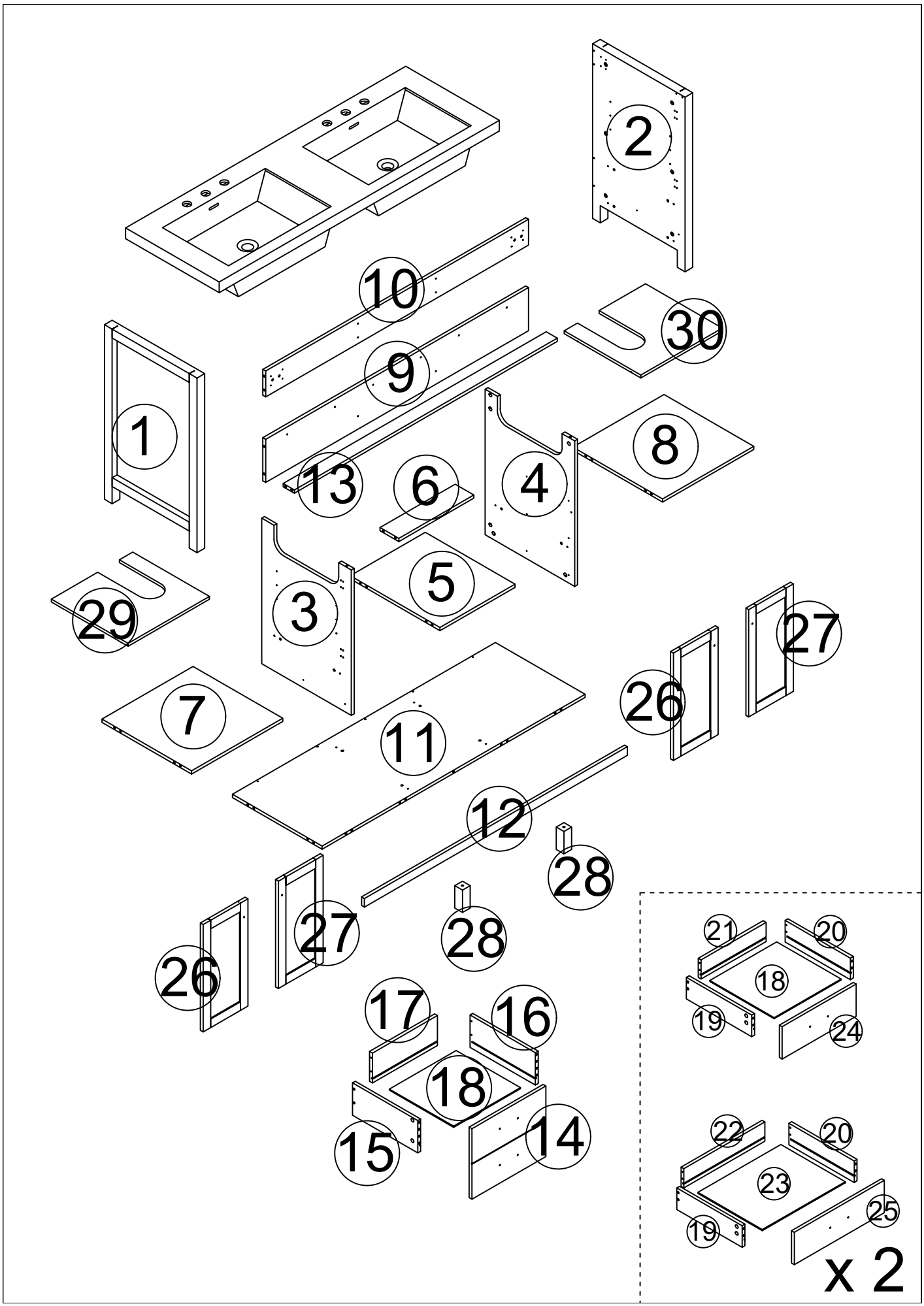

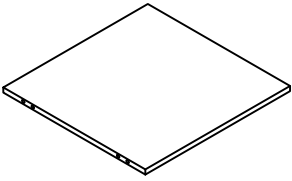
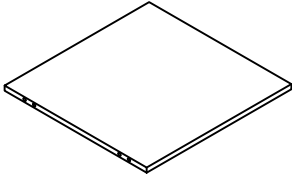
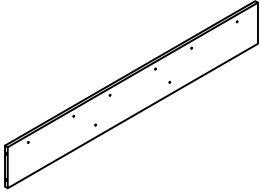
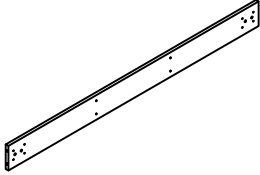
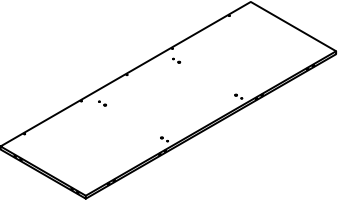
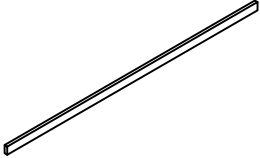
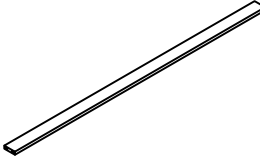
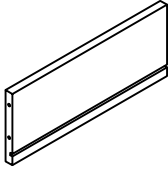
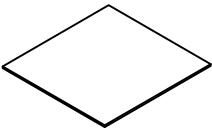
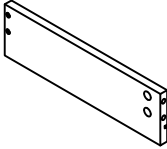
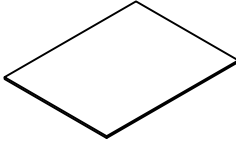

Box 1:N729P392155

			
⑦ x 1	⑧ x 1	⑨ x 1	⑩ x 1
			
⑪ x 1	⑫ x 1	⑬ x 1	⑰ x 1
			
⑱ x 3	⑲ x 2	⑳ x 2	

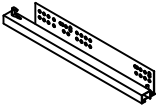
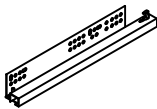
Box 1:N729P392155

				
L x 5	M x 5			

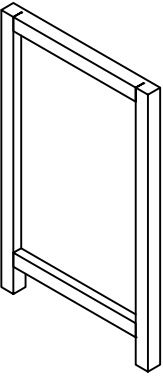
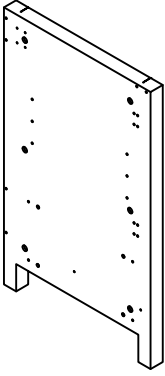
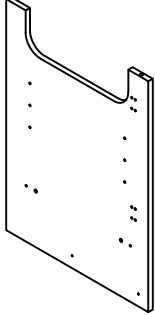
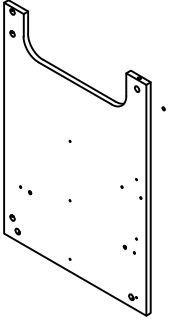
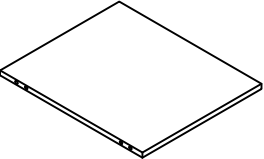
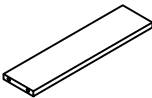
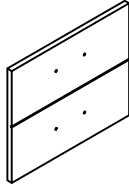
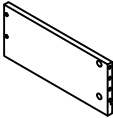
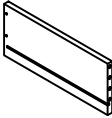
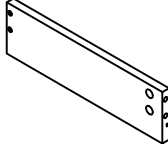
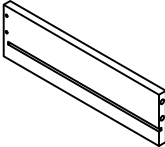
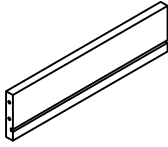
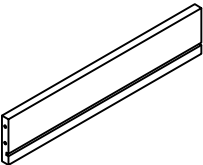
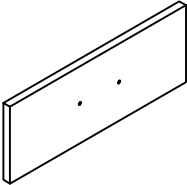
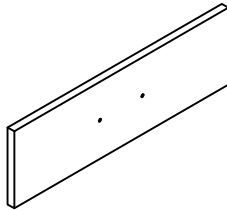
Box 2:N729P392156

			
① x 1	② x 1	③ x 1	④ x 1
			
⑤ x 1	⑥ x 1	⑭ x 1	⑮ x 1
			
⑯ x 1	⑲ x 2	⑳ x 4	㉑ x 2
			
㉒ x 2	㉔ x 2	㉕ x 2	㉖ x 2

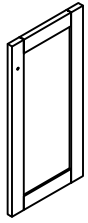

27 x 2

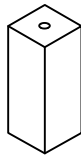

28 x 2

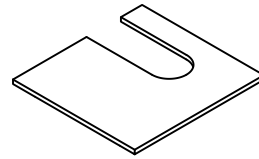

29 x 1

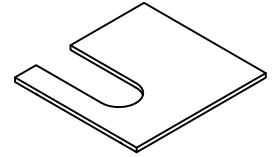

30 x 1

Box 2:N729P392156

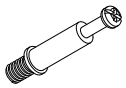

A x 74+6



Ø15x12mm
B x 74+4

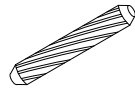

Ø8x30mm
C x 24+2



D x 4

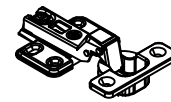

E x 8

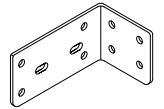

F x 2



Ø3.5x14mm
G x 60+22



Ø4x20mm
H x 10+2

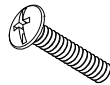

I x 4

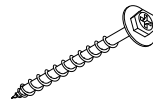

Ø6x60mm
J x 2

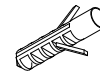

Ø8x40mm
K x 2



N x 6



O x 2



P x 2

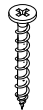

Ø4x35mm
Q x 26

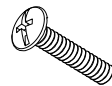

R x 12



S x 8+1



T x 2

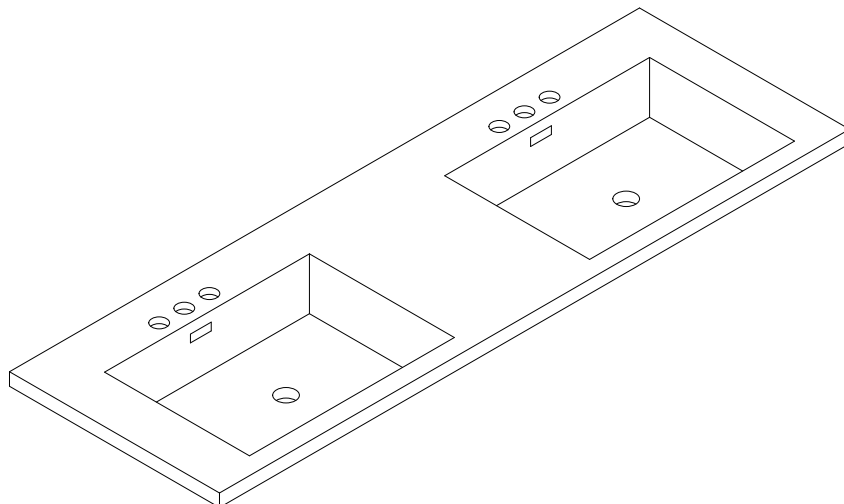

Step 1

x 2

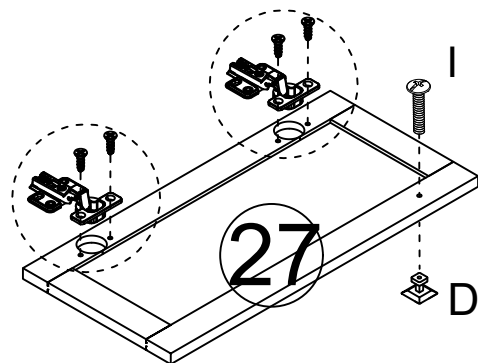
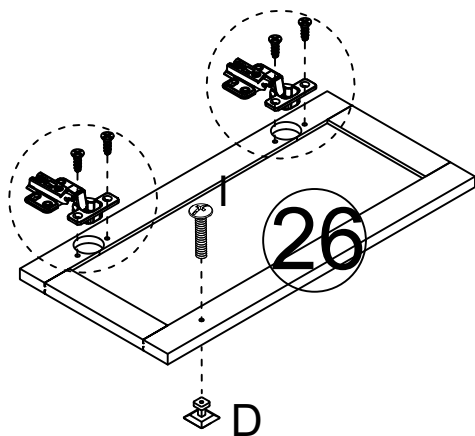

1. Attach two hinges (E) to panels No. 26 and No. 27 using G screws.
2. Install two handles (D) onto panels No. 26 and No. 27 using I screws.

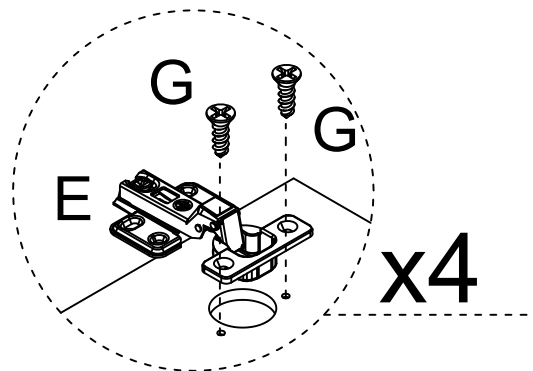
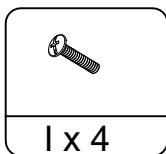
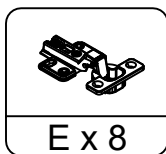
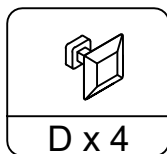

Step 2

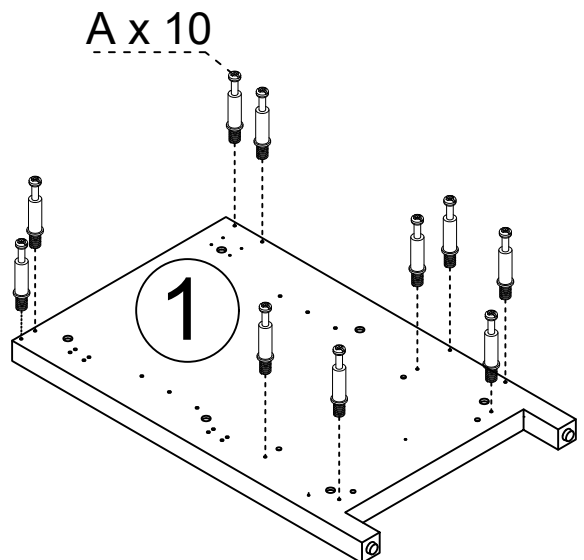
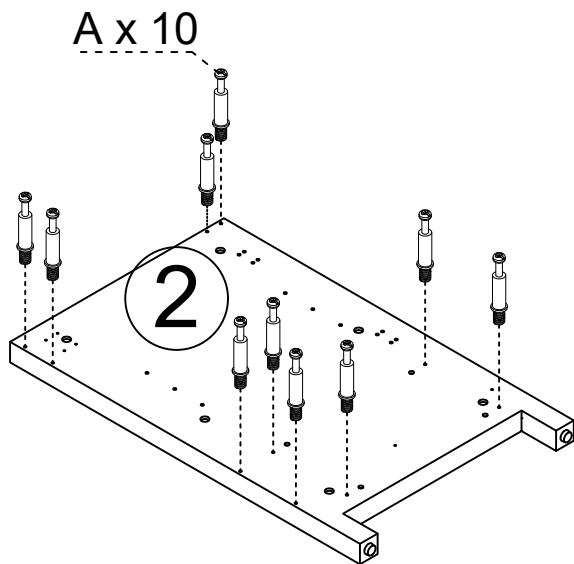

1. Insert ten position dowels (A) into the back sides of panels No. 1 and No. 2, and tighten them securely

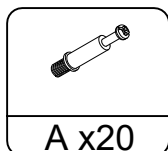

Step 3

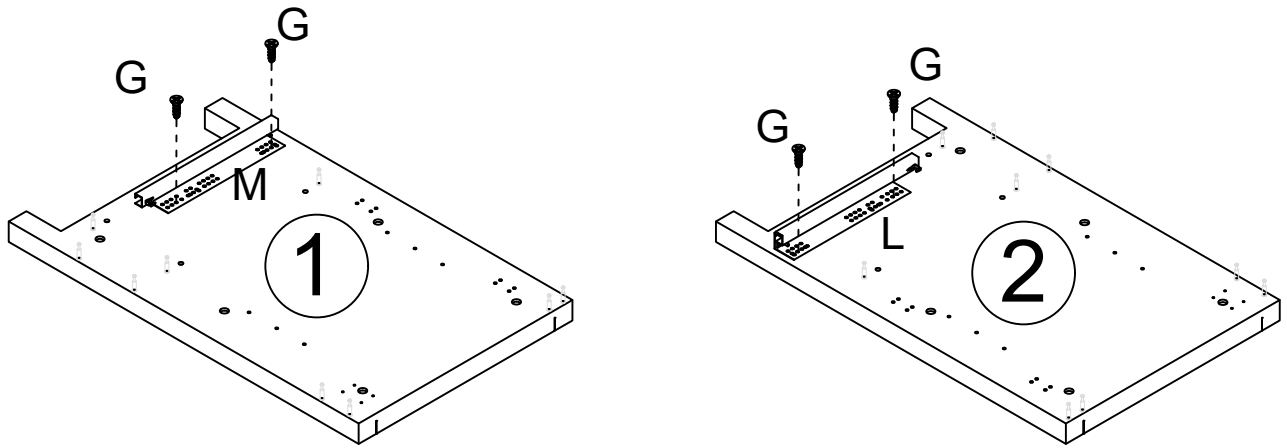

1. Attach the M drawer slide to panel No. 1 using two G screws.
2. Attach the L drawer slide to panel No. 2 using two G screws.

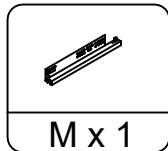
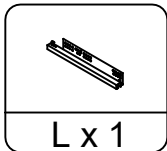
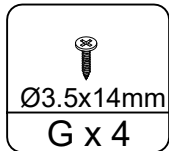
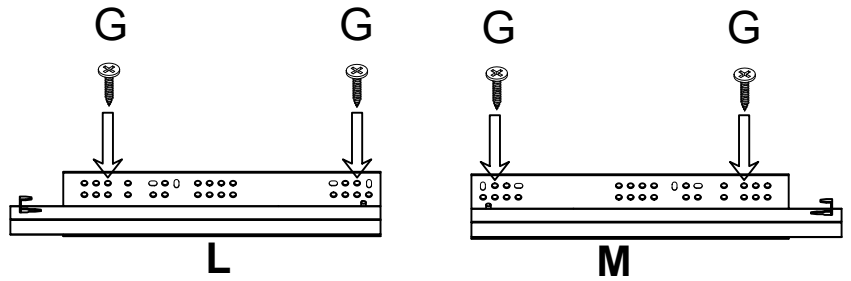

Step 4

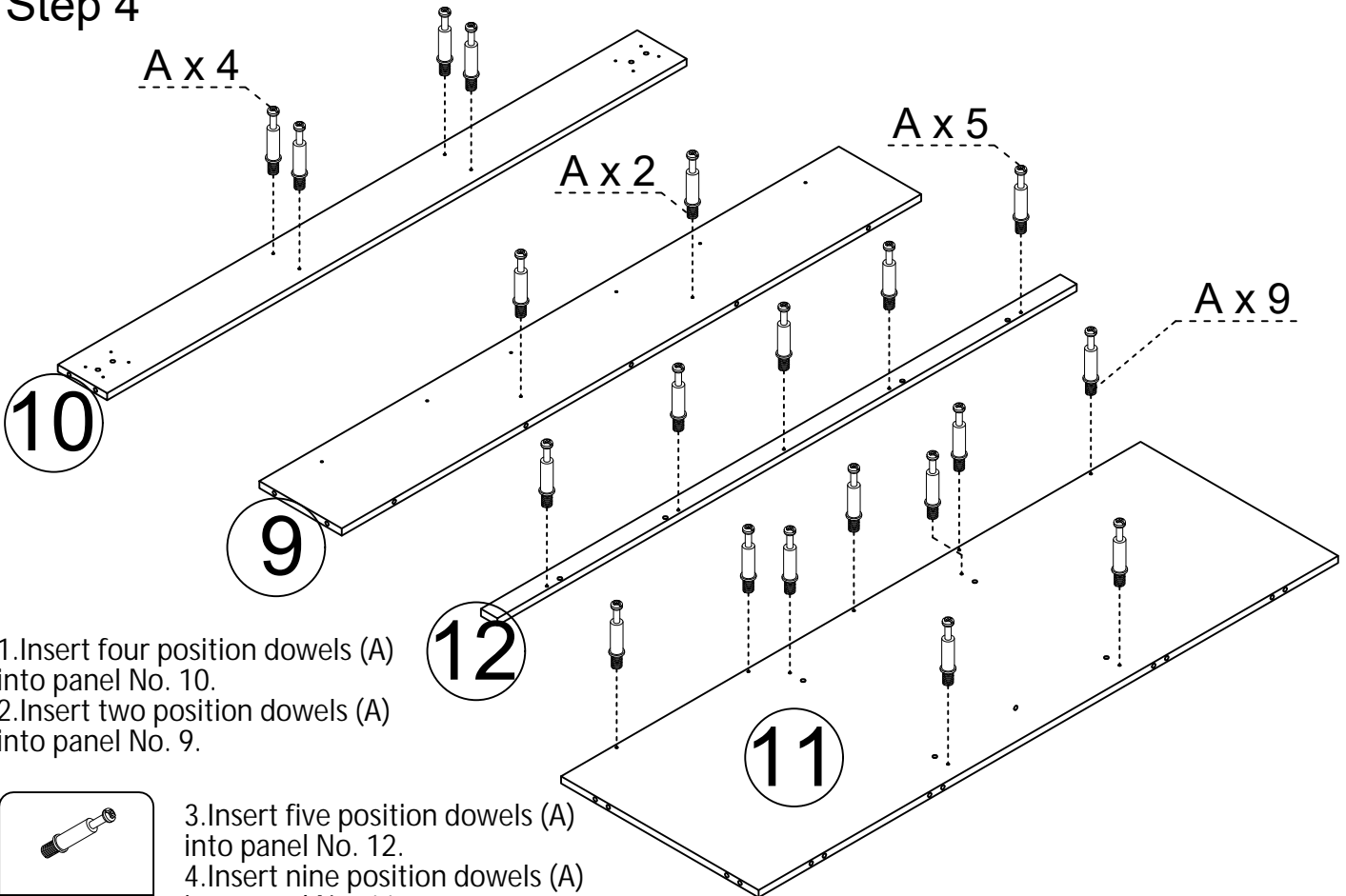

1. Insert four position dowels (A) into panel No. 10.
2. Insert two position dowels (A) into panel No. 9.

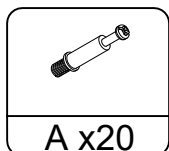

3. Insert five position dowels (A) into panel No. 12.
4. Insert nine position dowels (A) into panel No. 11.

Step 5

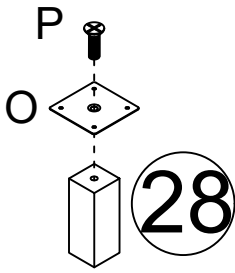
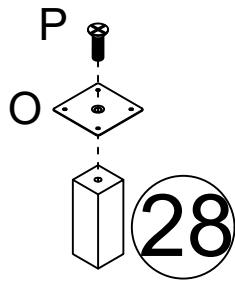

1. Secure the metal plate (O) to the wooden leg No. 28 using P screws.
2. Connect panel No. 12 to panel No. 11 with four wooden dowels.
3. Install five cam locks (B) into panel No. 11.

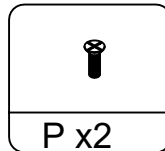
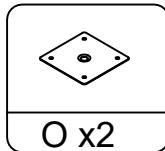
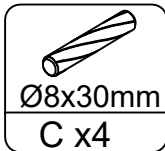
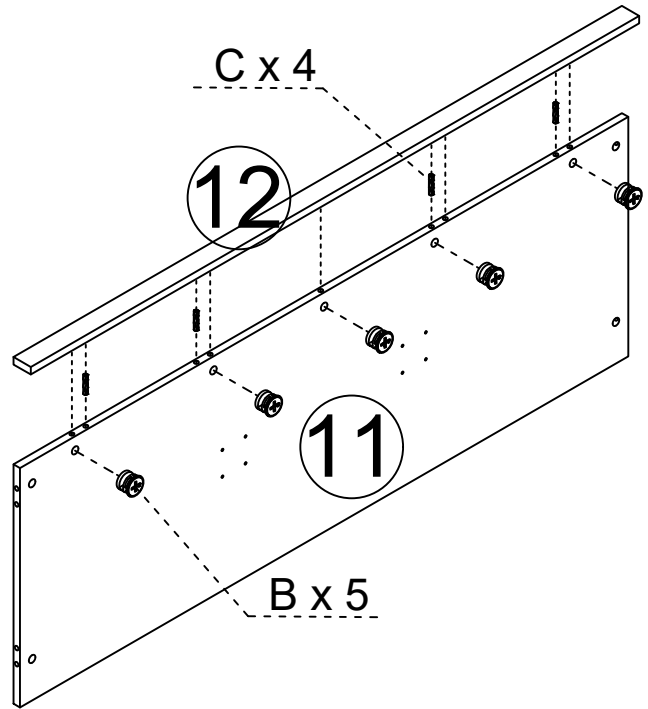

Step 6

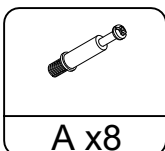
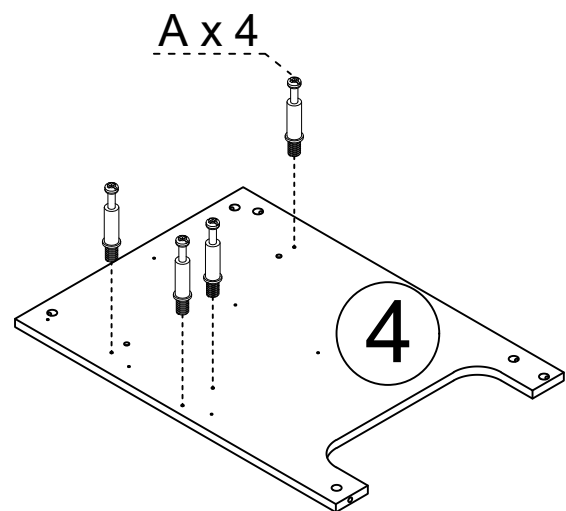
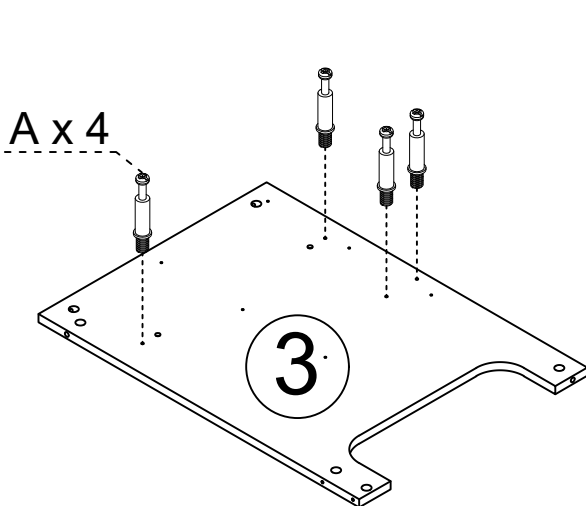

1. Insert four position dowels (A) into panel No. 3.
2. Insert four position dowels (A) into panel No. 4.

Step 7

1. Attach two M drawer slides to panel No. 3 using four G screws.
2. Attach two L drawer slides to panel No. 4 using four G screws.

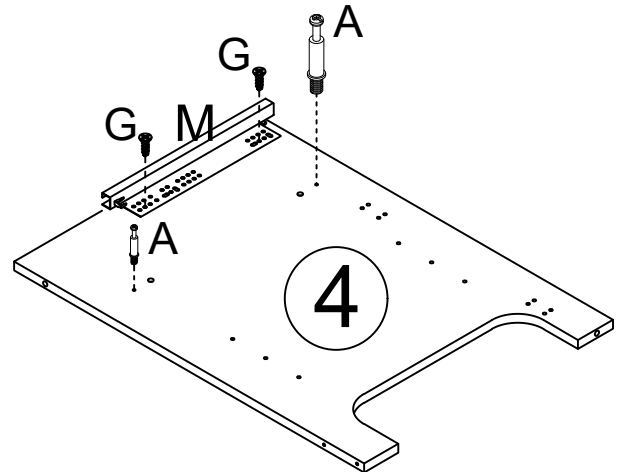
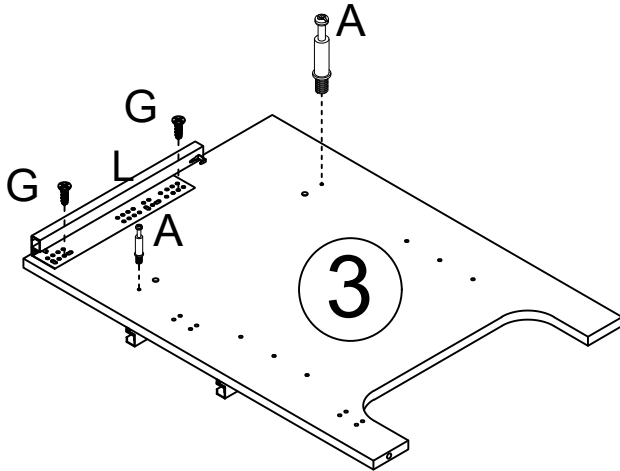
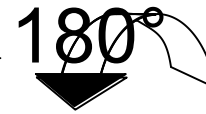
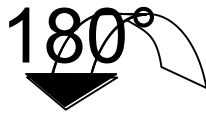
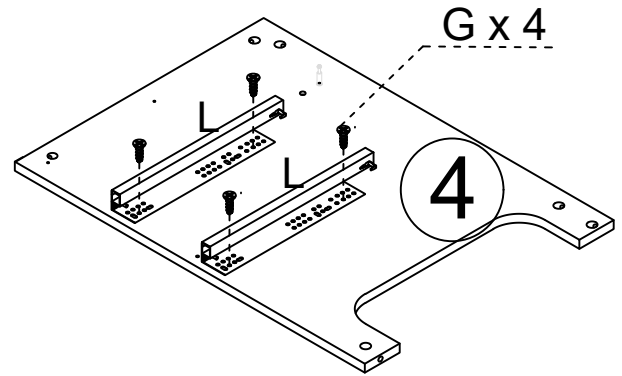
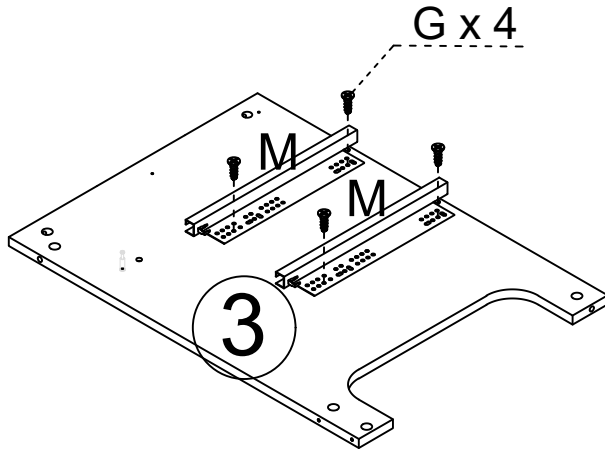
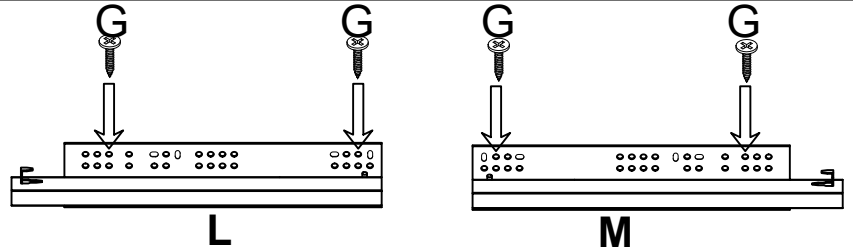

1. Flip panels No. 3 and No. 4 over 180 degrees.
 2. Attach one L drawer slide to panel No. 3 using two G screws.
 3. Attach one M drawer slide to panel No. 4 using two G screws.
- Insert two position dowels (A) into each of panels No. 3 and No. 4.

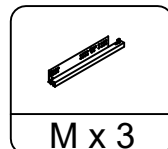
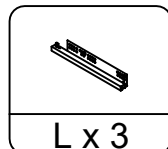
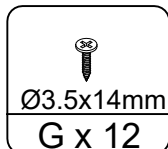
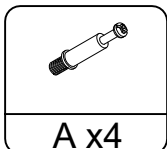
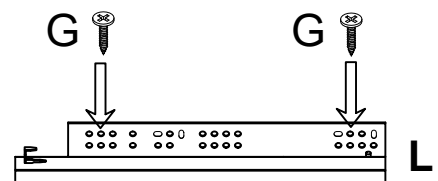
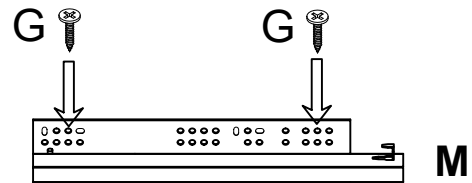

Step 8

1. Attach Panel No.6 to Panel No.3 and No.4 using four (4) Type B cam locks.
2. Insert four (4) Dowels C into Panel No.5, and secure with four (4) Type B cam locks.

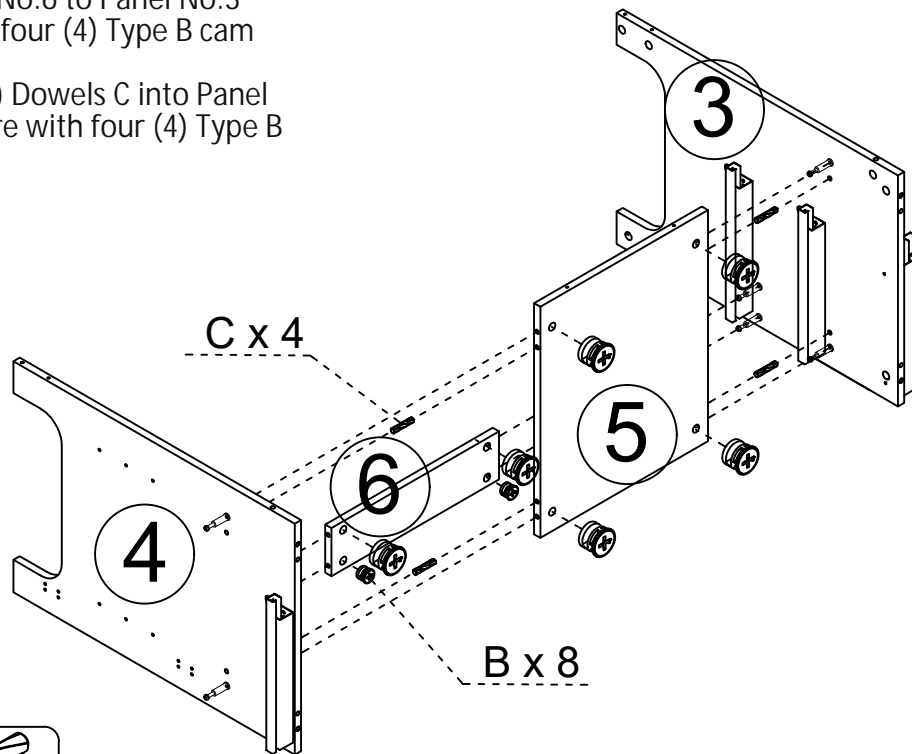

Step 9

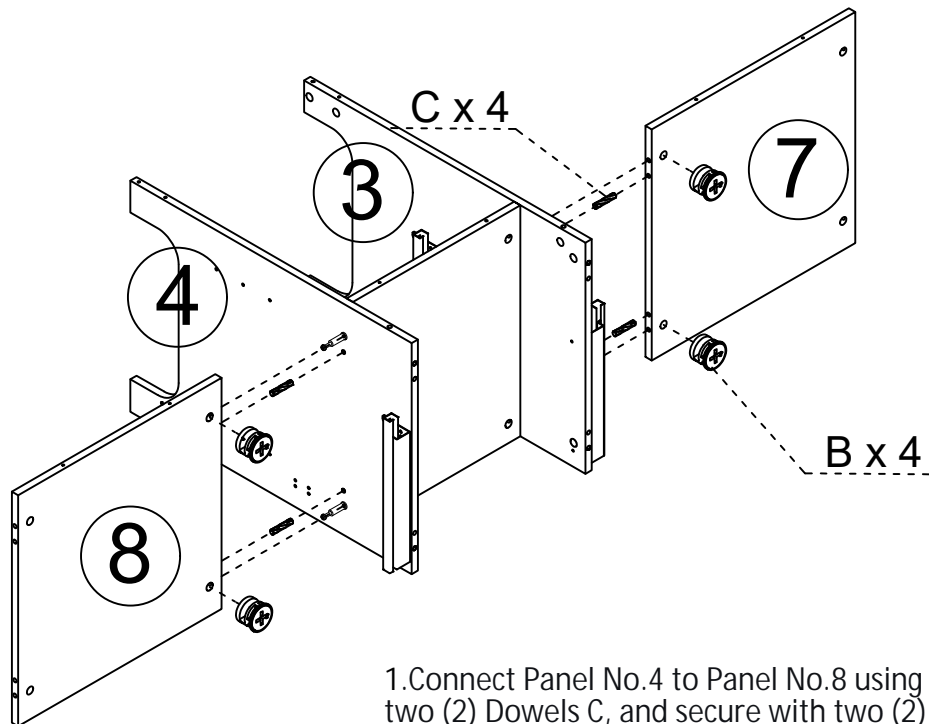

1. Connect Panel No.4 to Panel No.8 using two (2) Dowels C, and secure with two (2) Type B cam locks.
2. Connect Panel #3 to Panel No.7 using two (2) Dowels C, and secure with two (2) Type B cam locks.

Step 10

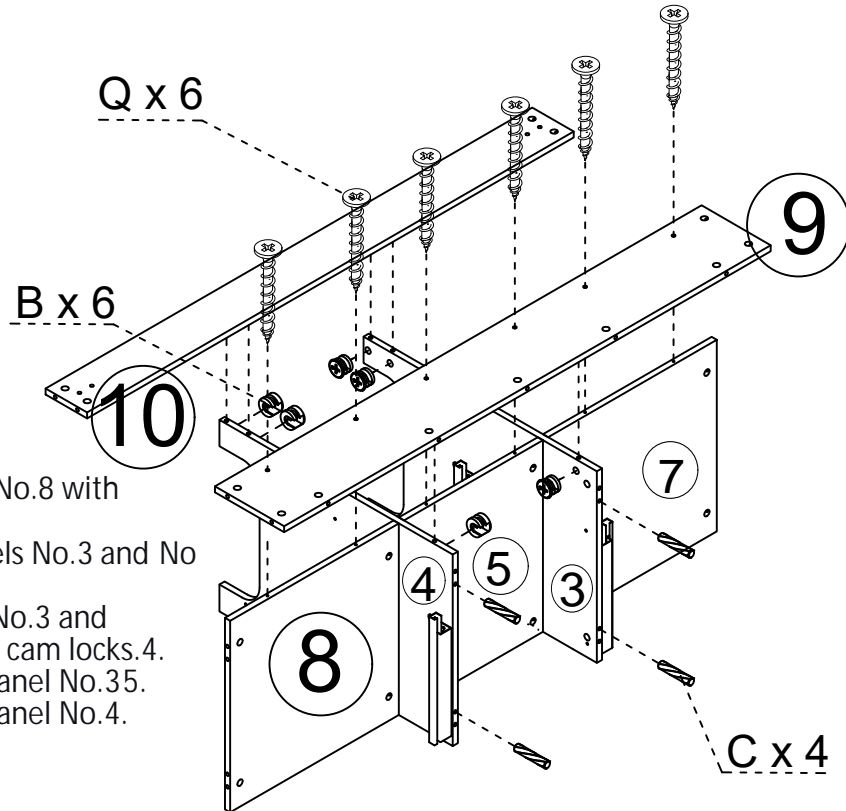

1. Secure Panel No.9 to Panel No.8 with six (6) Type Q screws.
2. Install the cam locks to Panels No.3 and No.4.
3. Attach Panel #10 to Panels No.3 and No.4, and secure with four (4) cam locks.
4. Insert two (2) Dowels C into Panel No.35. Insert two (2) Dowels C into Panel No.4.

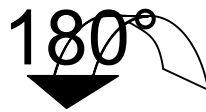
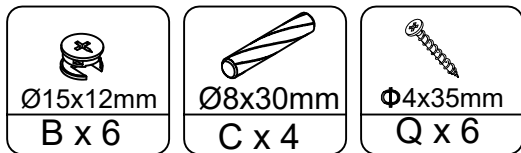

6. Rotate the entire assembled unit 180 degrees.
7. Secure two (2) Type A positioning rods to Panel No.13, then attach two (2) door stoppers T.

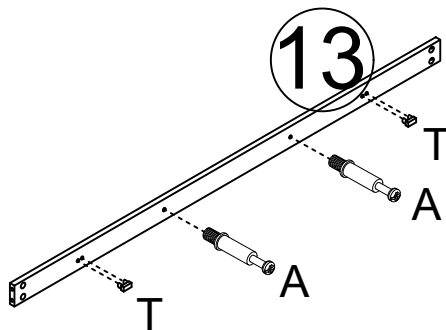

8. Connect Panel No.11 to Panels No.3 and No.4, and secure with four (4) Type B cam locks.
9. Connect Panel No.13 to Panels No.3 and No.4, and secure with two (2) Type B cam locks.

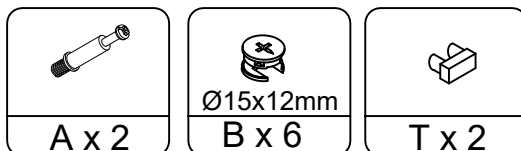
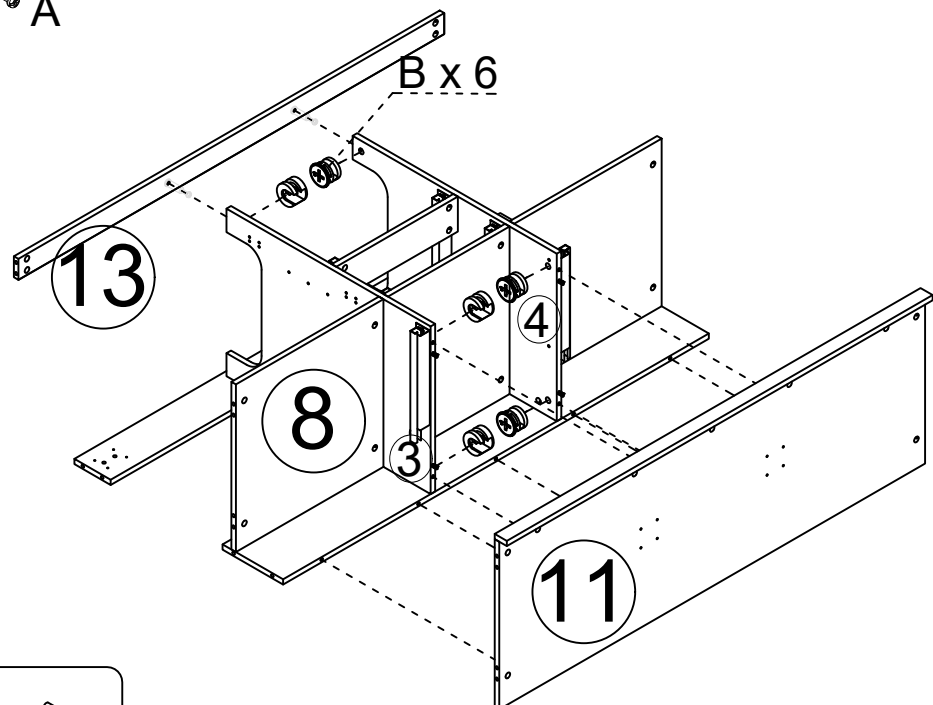

Step 11

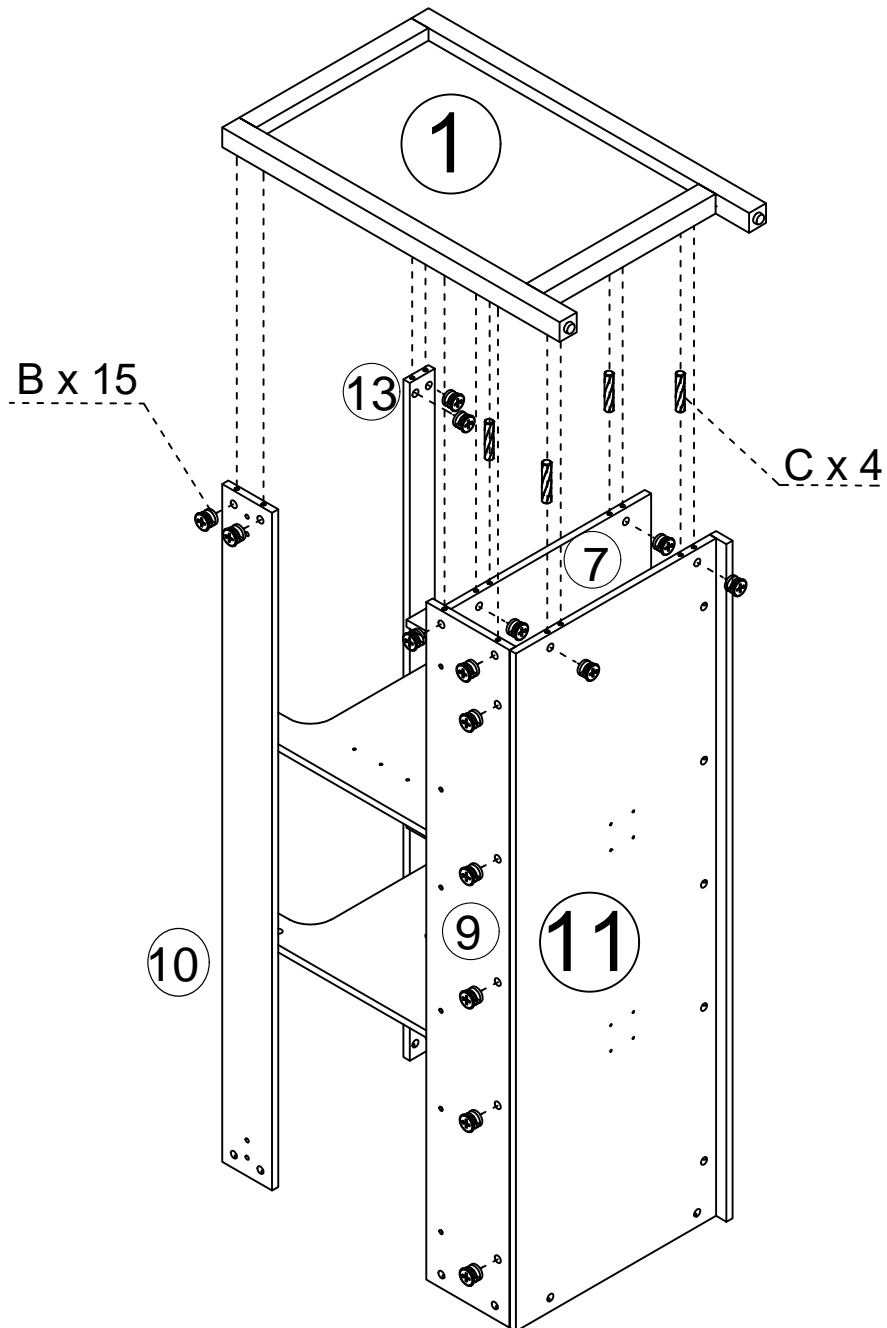

1. Connect Panel No.1 to Panels No.7 and No.11 using four (4) dowels.
2. Secure Panel No.1 to the main assembly (Panels No.7, No. 9, No.10, No.11, No.13) with fifteen (15) Type B screws.

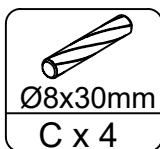

Step 12

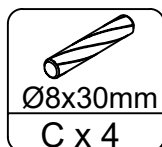
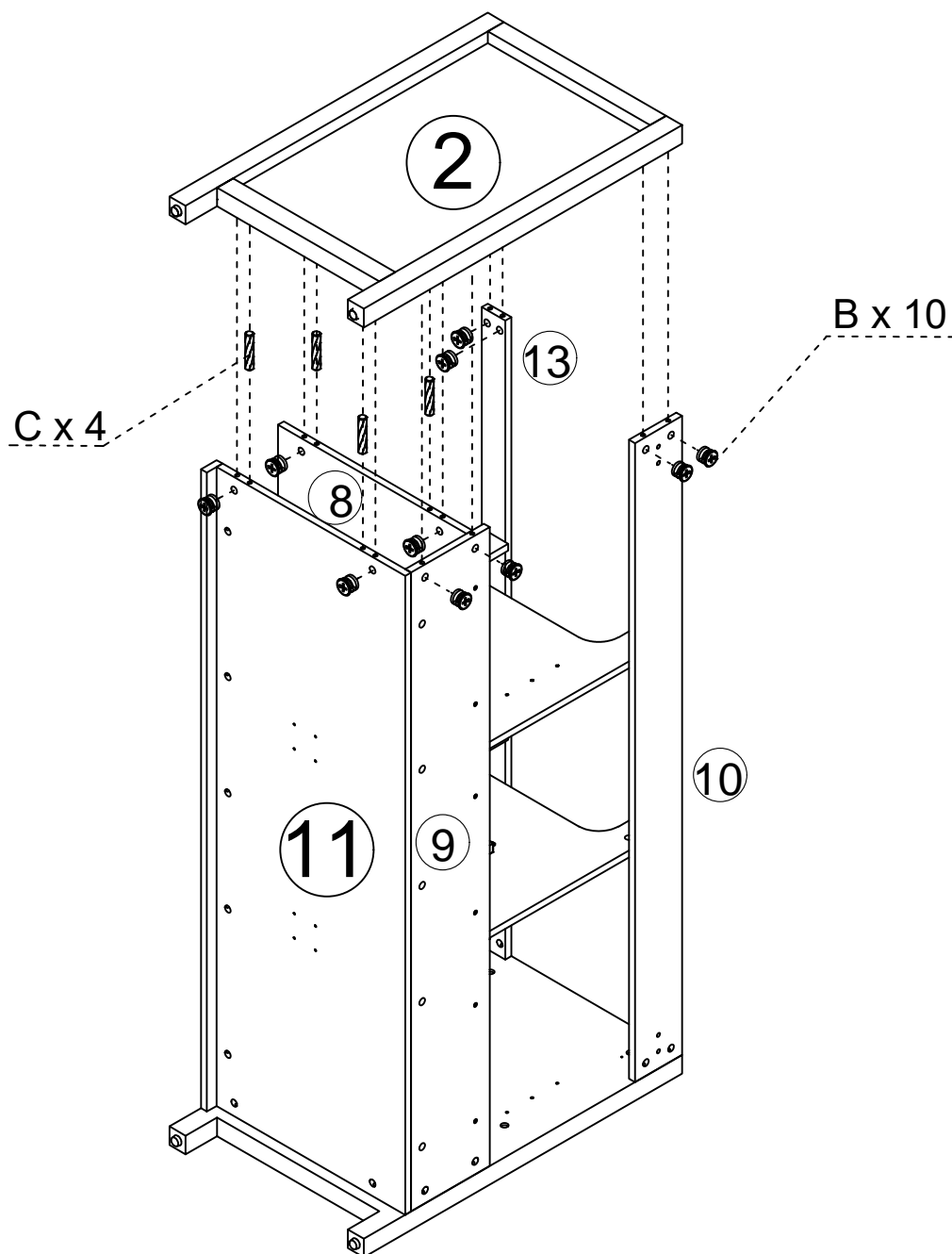

1. Connect Panel NO.2 to Panels NO.8 and NO.11 using four (4) dowels.
2. Secure Panel NO.2 to the main assembly (Panels NO.8, NO.9, NO.10, NO.11, NO.13) with fifteen (15) Type B screws.

Step 13

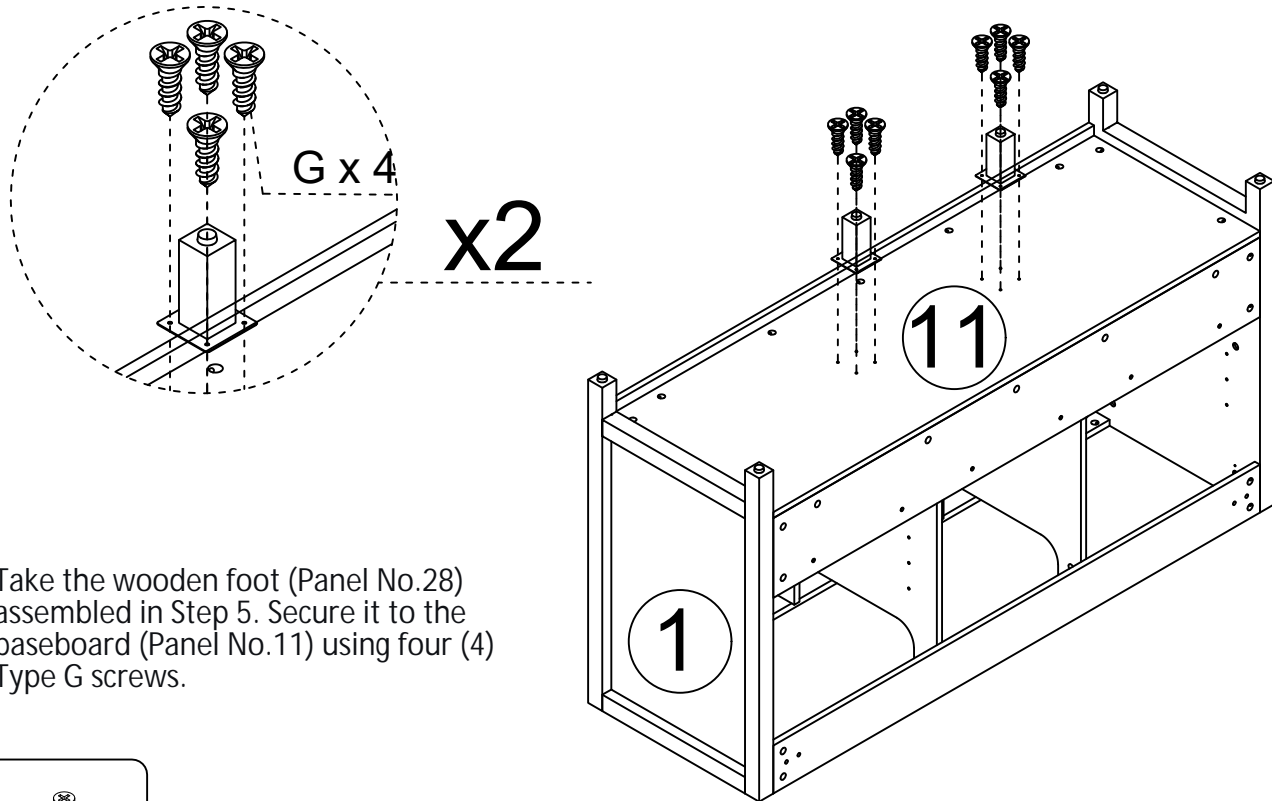

Take the wooden foot (Panel No.28) assembled in Step 5. Secure it to the baseboard (Panel No.11) using four (4) Type G screws.



Step 14

1. Secure slide rail M to Panel No.3 with two (2) Type G screws. 2. Secure slide rail L to Panel No.4 with two (2) Type G screws.

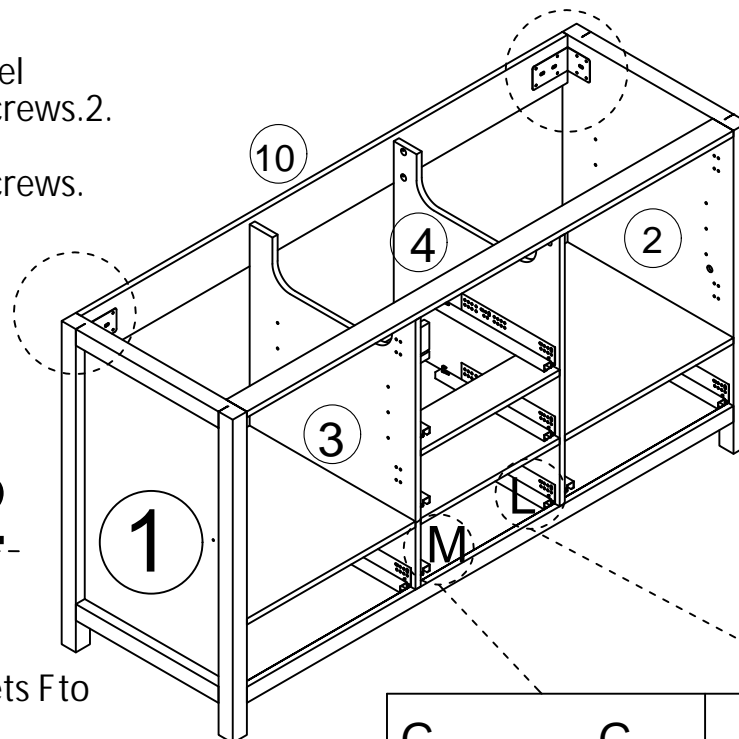
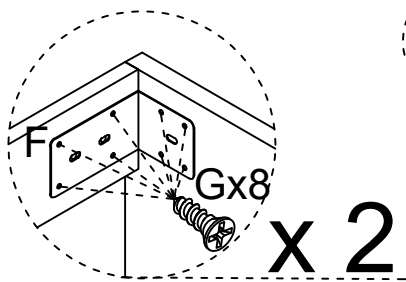

3. Attach mounting brackets F to Panels No.1 and No.2 using a total of eight (8) Type G screws.

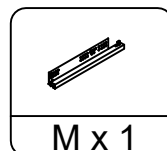
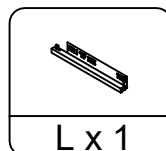
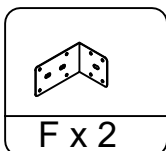
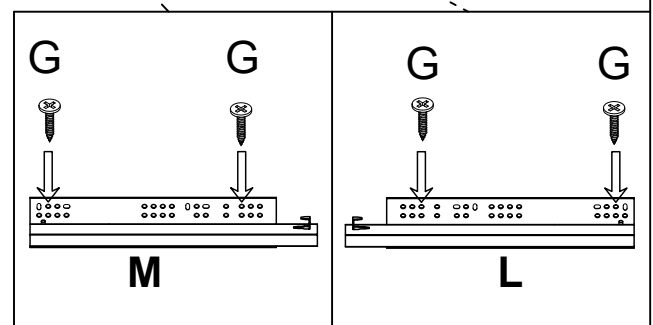

Step 15

Connect Panel No.17 to Panel No. 15 and Panel No.16 using two (2) Type Q screws for each joint.

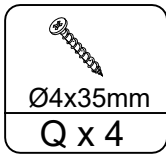
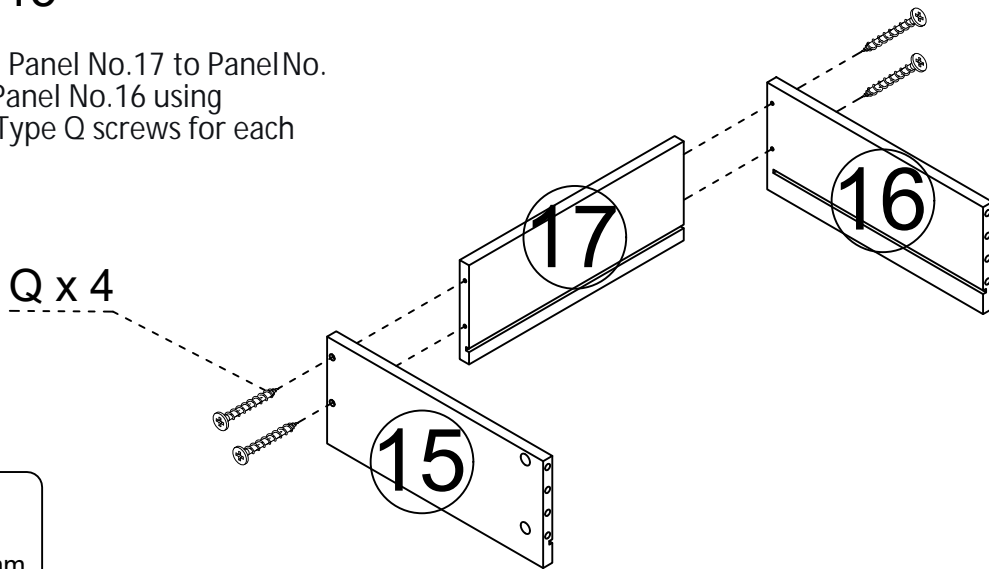

Install four (4) positioning rods A onto the drawer front (Panel No.14). Insert Panel No.18 into the slots on Panels No. 15, No.16, and No.17.

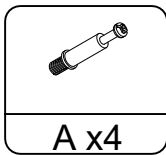
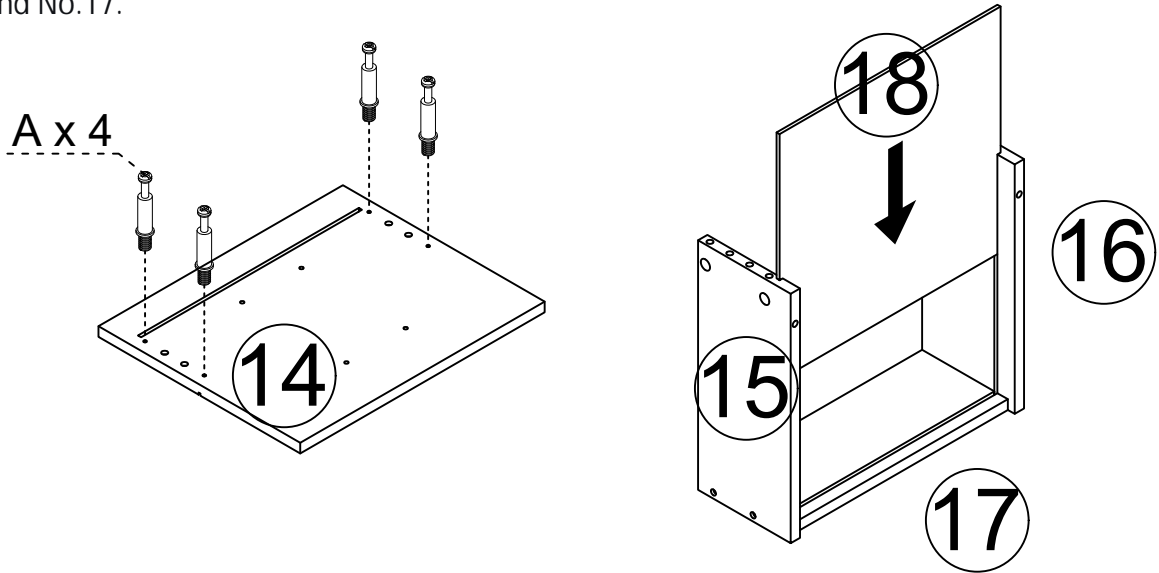

Secure the drawer front (Panel No.14) to the drawer assembly (Panels No.15, No.16, No.18) using four (4) Dowels C and four (4) Type B cam locks.

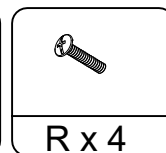
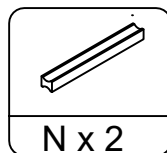
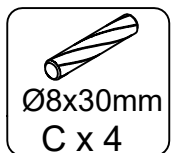
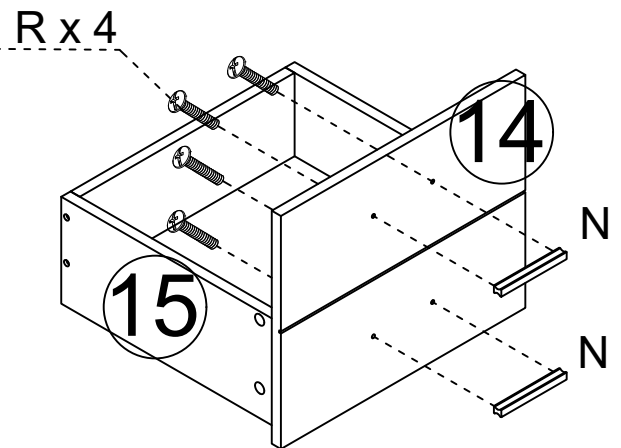
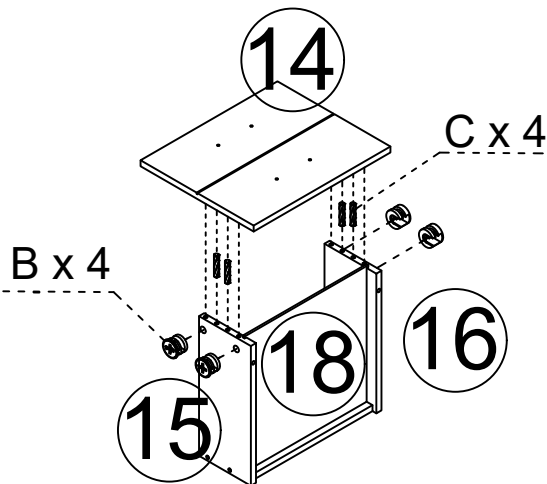

Mount two (2) handles N onto the drawer front (Panel No.14) with four (4) Type R screws.

Step 16

Connect Panel No.21 to Panel No. 19 and Panel No.20 using two (2) Type Q screws for each connection.

Q x 4

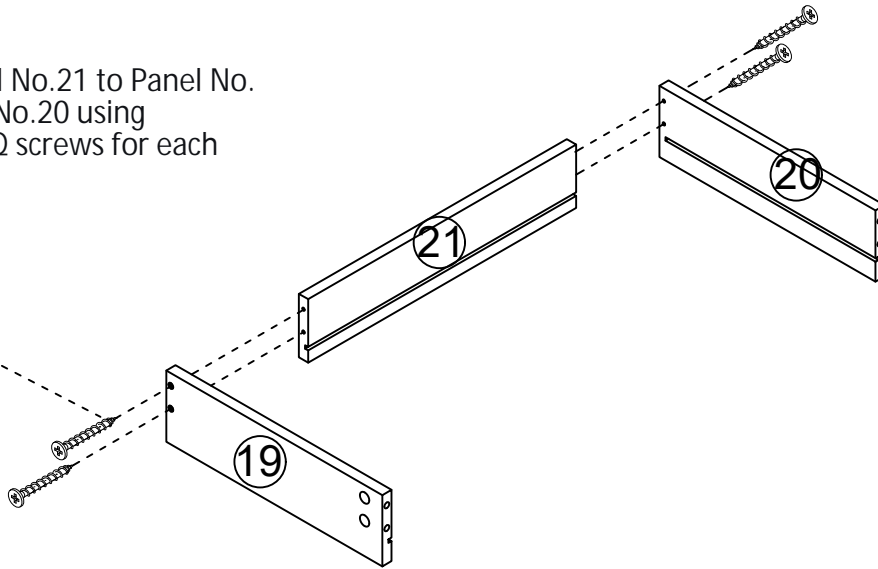

x 2

Install four (4) positioning rods A onto the drawer front (Panel No. 24). Insert Panel No.18 into the slots on Panels No.19, No. 20, and No.21.

A x 4

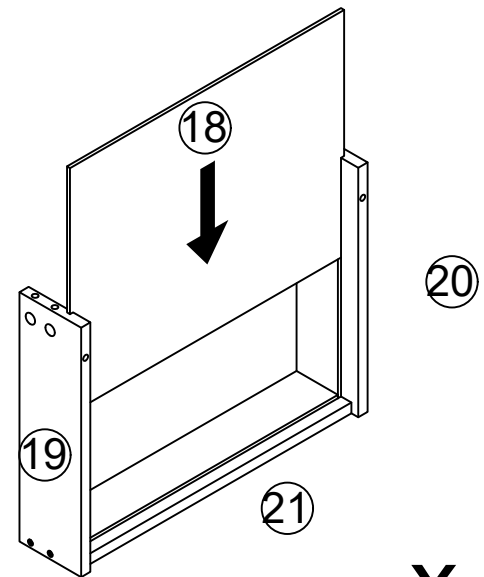
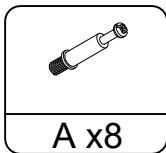
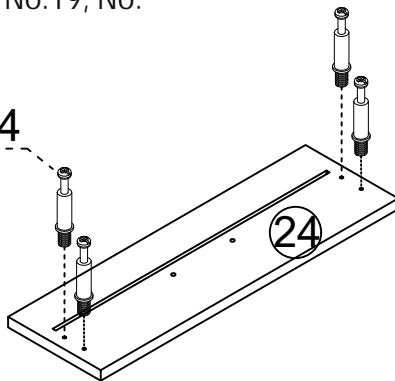

x 2

Secure the drawer front (Panel No.24) to the drawer assembly (Panels No.18, No.19, No.20) using four (4) cam locks. Mount one (1) handle N onto the drawer front (Panel No.24) with two (2) Type R screws.

B x 4

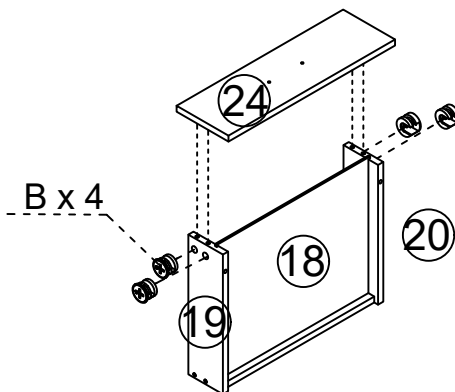

R x 2

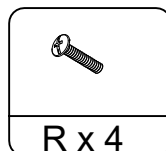
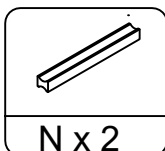
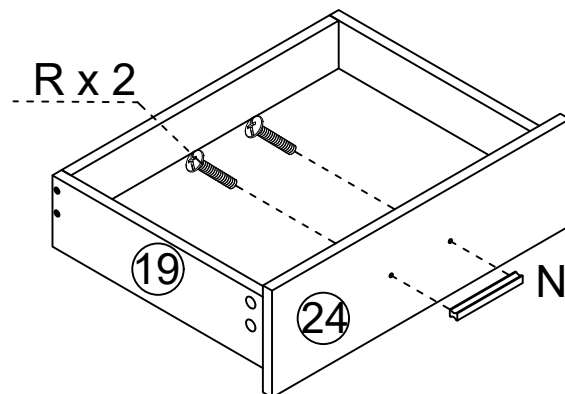

x 2

Step 17

Connect Panel No.22 to Panel No.19 and Panel No.20 using two (2) Type Q screws for each connection.

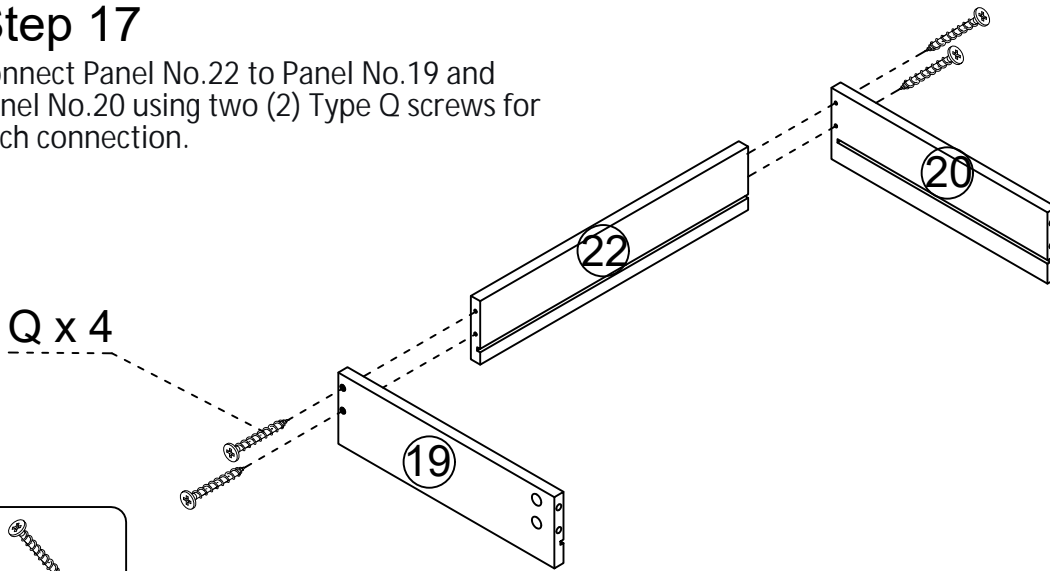

Q x 4



x 2

Install four (4) positioning rods A onto the drawer front (Panel No.25). Insert Panel No.23 into the slots on Panels No.19, No.20, and No.22.

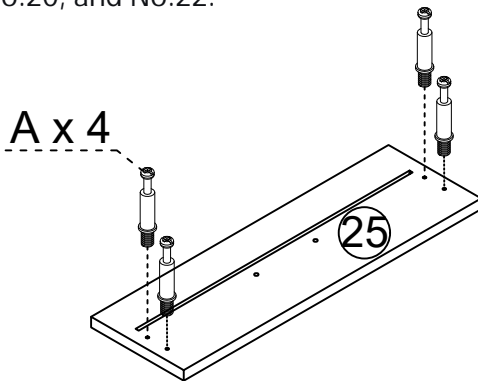

A x 4

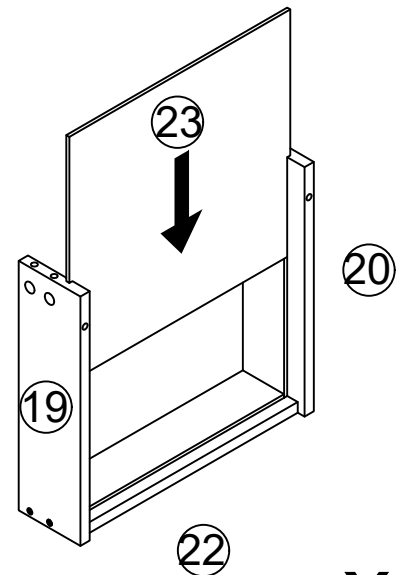
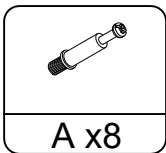

x 2

Secure the drawer front (Panel No.25) to the drawer assembly (Panels No.19, No.20, No.23) using four (4) cam locks. Mount one (1) handle N onto the drawer front (Panel No.25) with two (2) Type R screws.

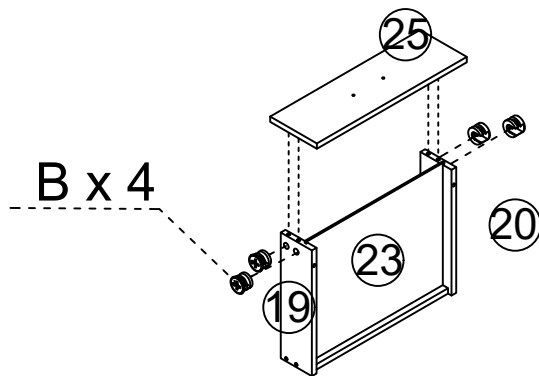

B x 4

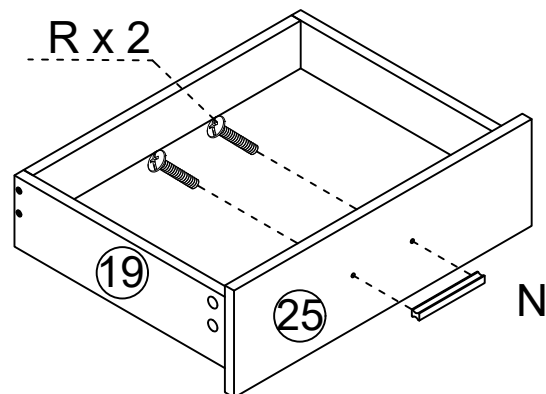
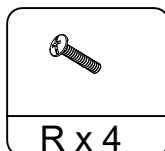
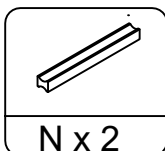

R x 2

x 2

Step 18

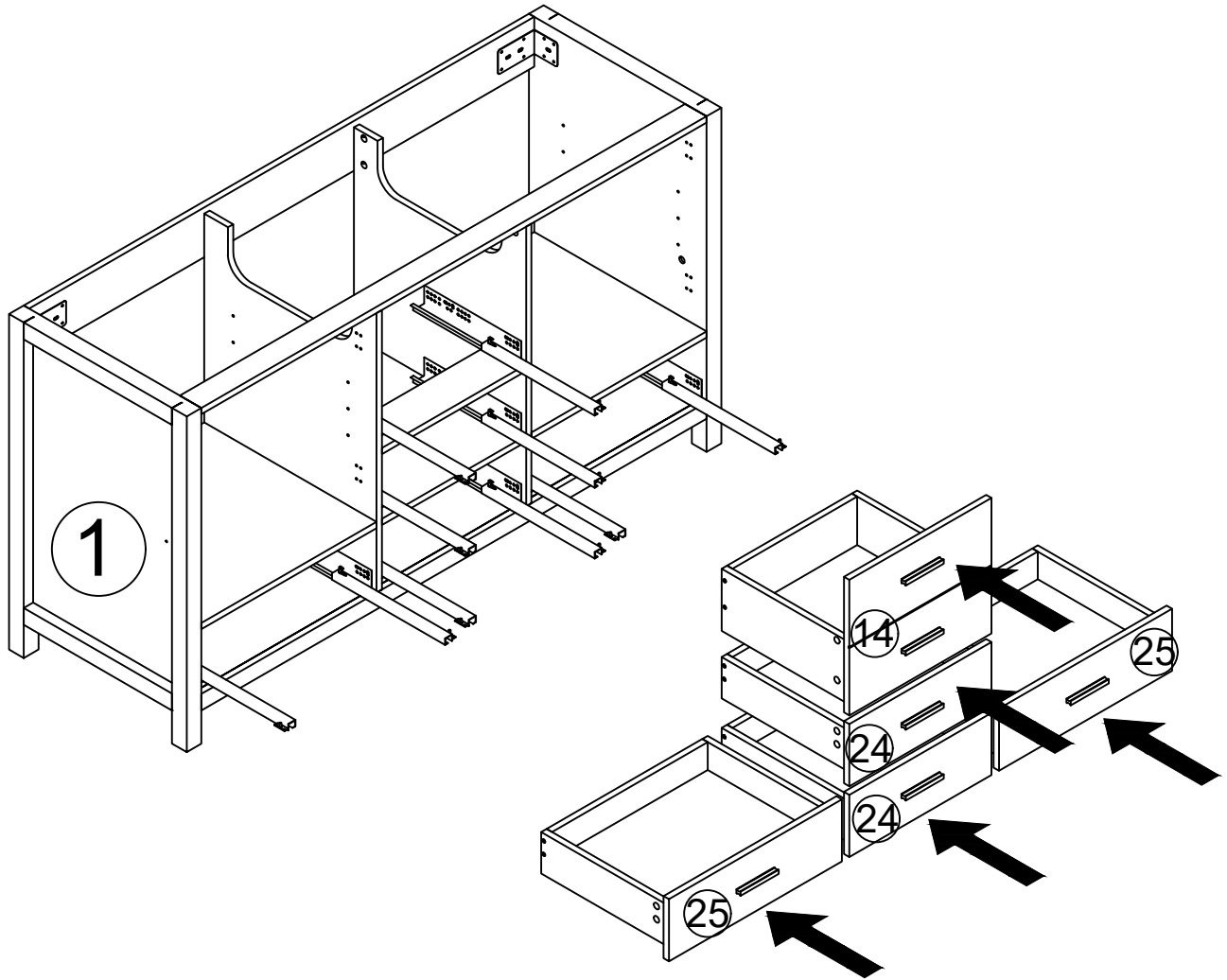

Place the five (5) assembled drawers onto the slide rails. Secure each drawer by driving two (2) Type H screws through the drawer into the rail, as shown in the illustration below.

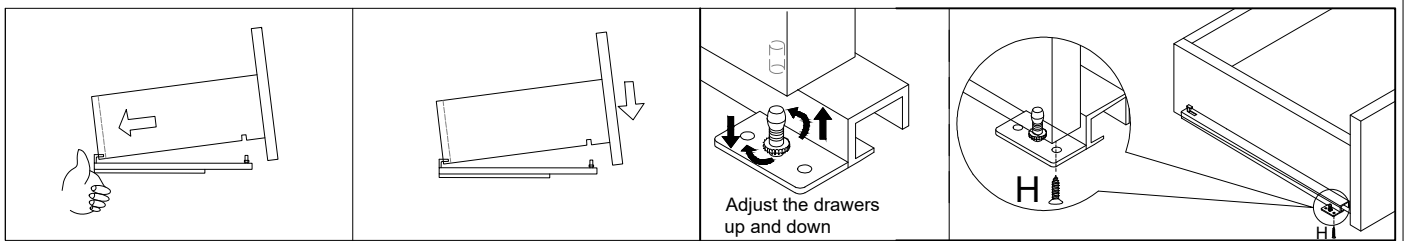

Step 19

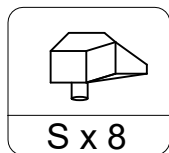
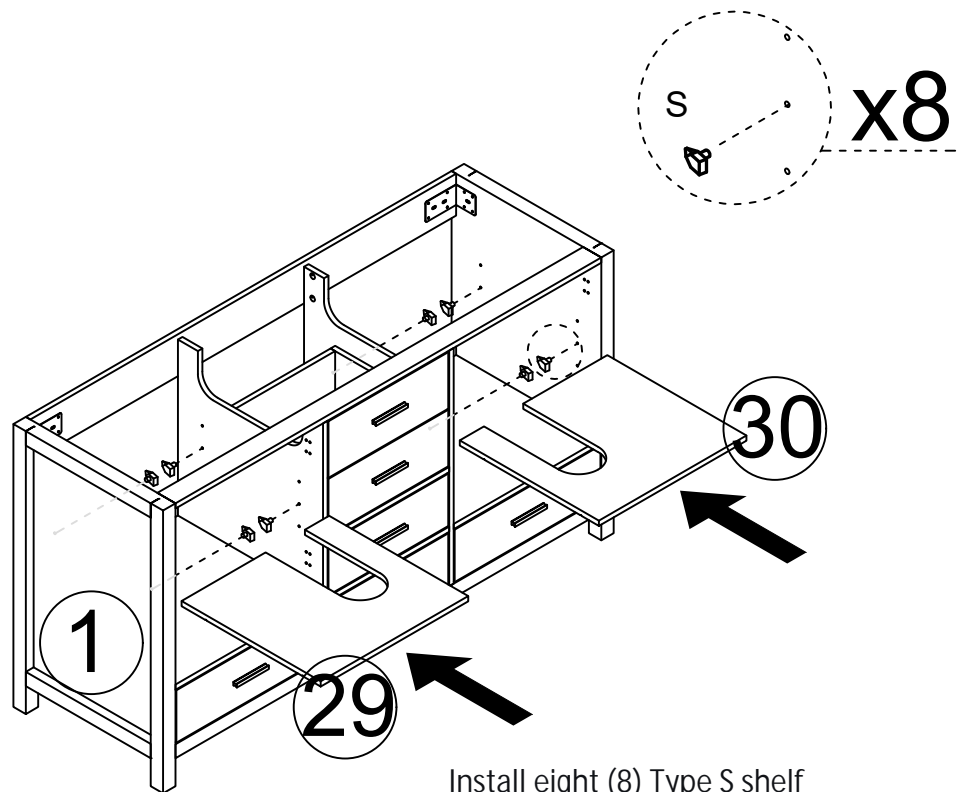

Install eight (8) Type S shelf supports into the cabinet. Place Panel No. 29 and Panel No. 30 onto the installed shelf supports.

Step 20

SETTINGS DOORS

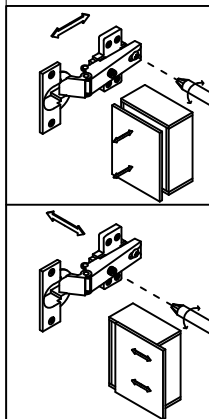

If the hinge holes are not aligned, you can try adjusting the front and rear hinges.

If the door gap is large, you can adjust the hinges left and right

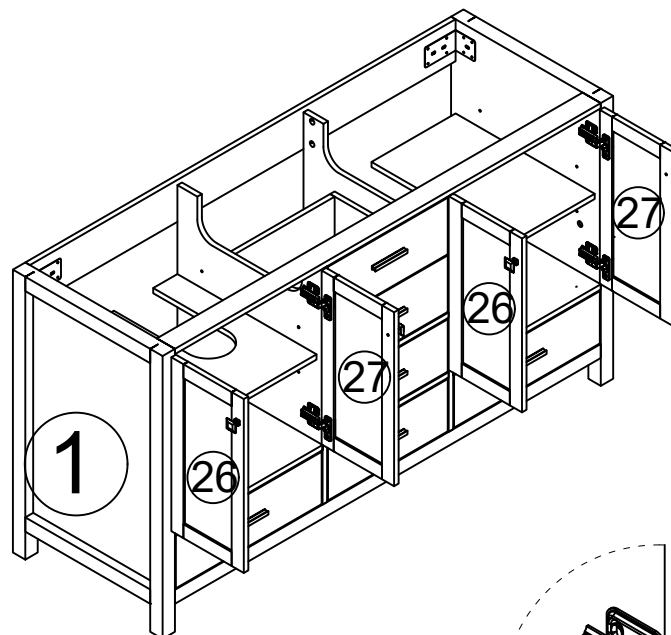

Secure each hinge using four (4) Type G screws.

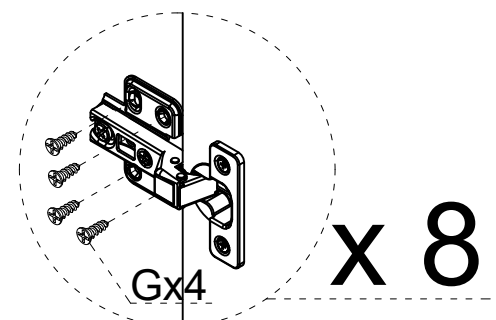

Step 21

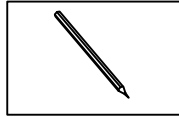
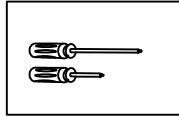
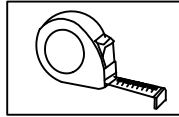
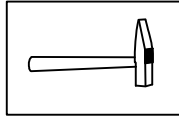
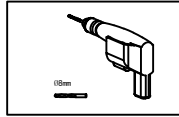

step 1

WALL

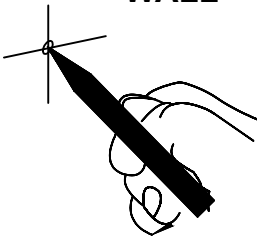

step 2

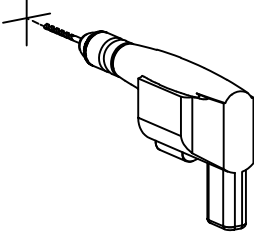

step 3

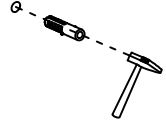

step 4

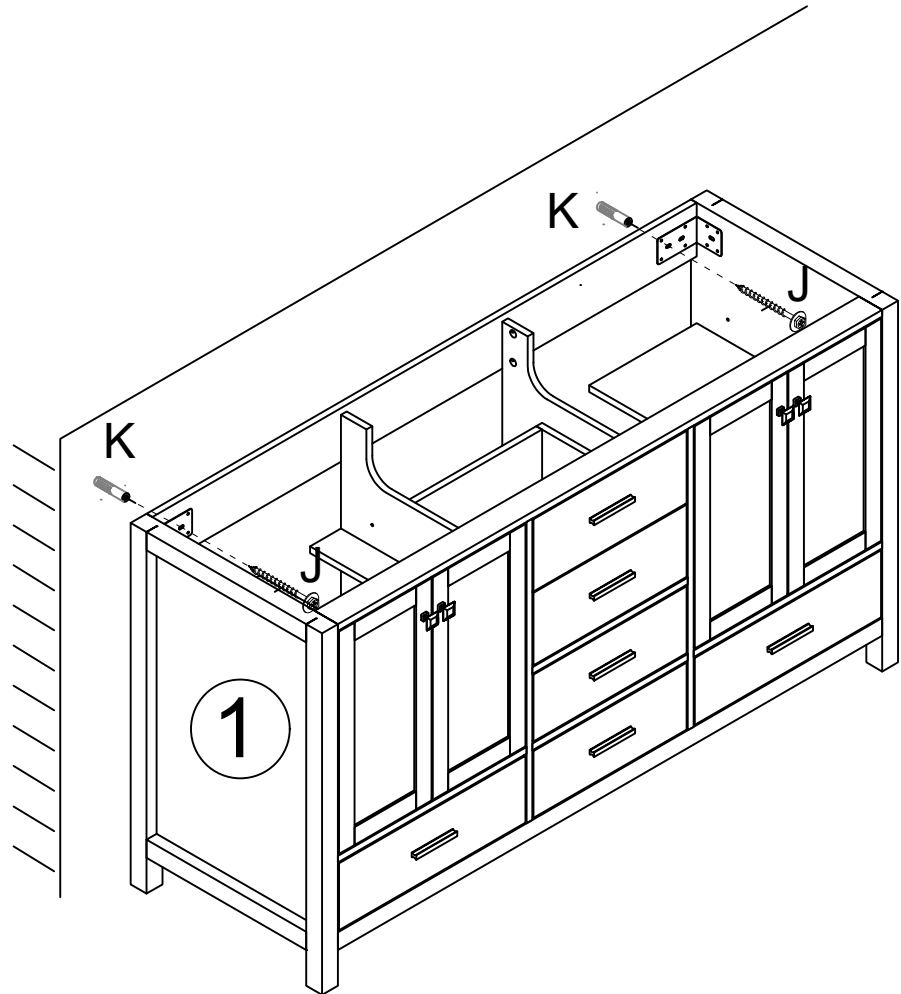
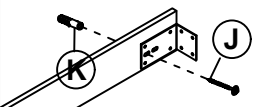

Mark the drilling positions on the wall.
Drill holes at the marked positions.
Tap the wall anchors K into the drilled holes.
Drive the screws J into the wall anchors K.

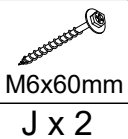

M6x60mm

J x 2



Φ8x40mm

K x 2

Step 22

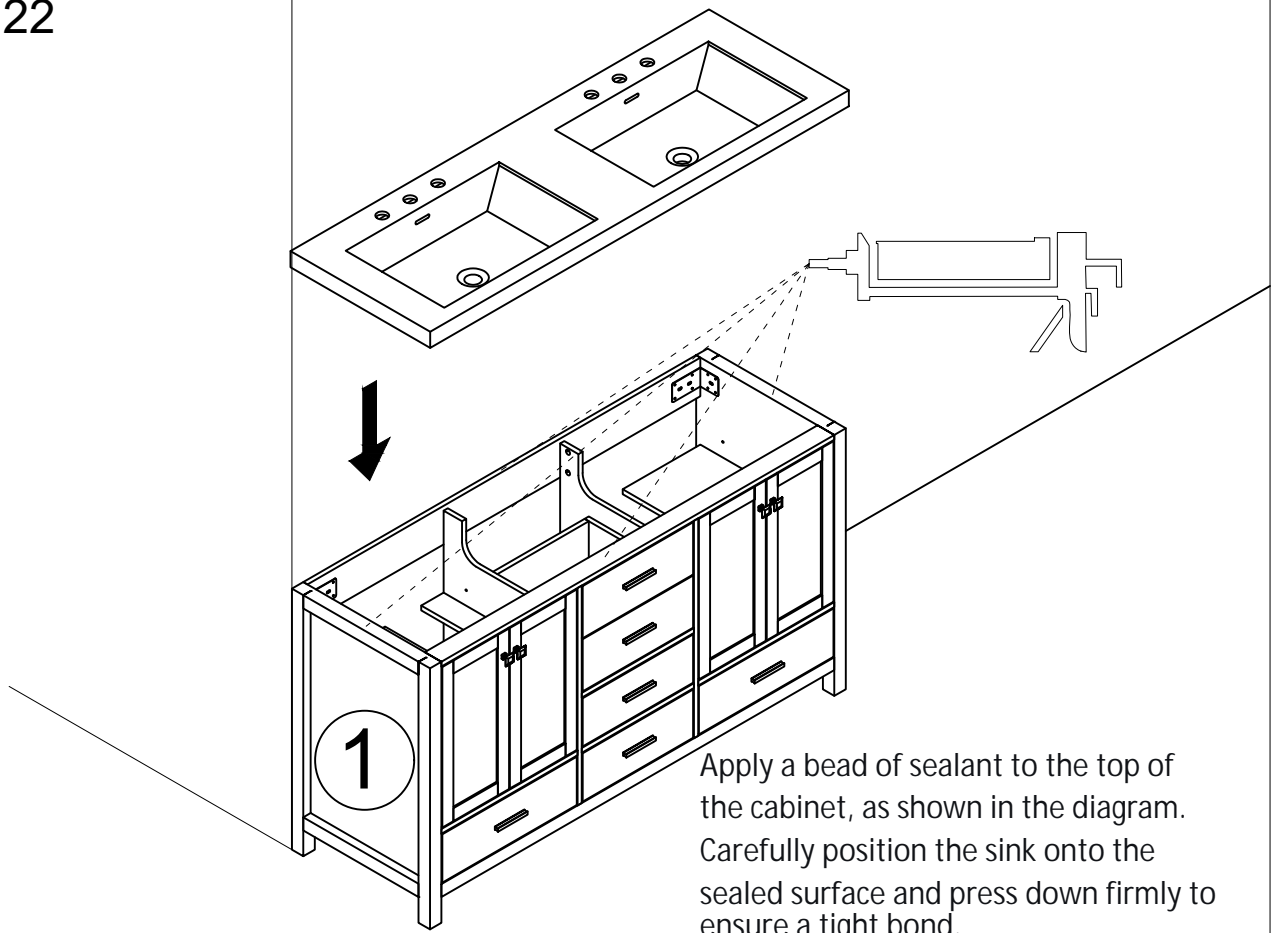

Step 23

