

Dome 60/02

Design / Diseño:
Benedetta Tagliabue | EMBT / 2015

Typology: Pendant lamp
Tipología: Suspensión

Environment: Indoor
Ambiente: Interior

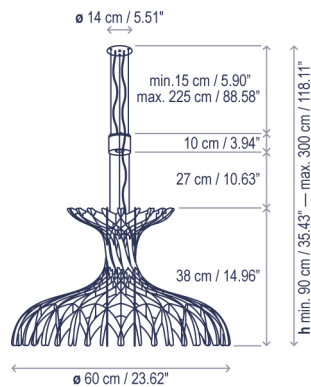

Technical description / Descripción técnica:

 Net Weight: 6.08 lbs
Peso Neto: 6.08 lbs

 1 Box/Caja
26.38 x 26.38 x 22.44 inches | 9.0361 ft³
Gross Weight / Peso bruto: 11.02 lbs

Materials: Iron, Aluminum, Wood finished beech.

Materiales: Hierro, Aluminio, Madera acabado haya.

The light is above the structure to illuminate throughout the open and diffused portions casting beautiful shadow patterns on surfaces below.

La fuente de luz está situada sobre la estructura, proyectando bellos mosaicos de luz en las superficies inferiores.

The additional LED source on the Dome 60/02 allows for more focused illumination on surfaces below, while the upper light provides for ambient light.

La fuente de luz adicional de la Dome 60/02 proporciona luz directa a la superficie inferior, el LED ubicado sobre la pantalla ofrece luz de ambiente.

Not customizable
No Personalizable

Certifications
Certificaciones   

Lamps description / Descripción lámpara:

 120-277V
50/60Hz | DRY | IP-20 |  25 W LED / CRI: 90 / 2700K
2664 lm light source / fuente de luz

Ref	Finishing / Acabados	Ean13
2580721000U/P829	Dimmable 0-10V - Matte White Natural Wood Shade Dimable 0-10V - Blanco Mate Pantalla Madera Natural	8435493716398

bover
barcelona lights

1251 Collier Road,
Suite C
Atlanta, GA 30318
United States

T. +1 (404) 924 2342
info@boverusa.com
www.boverusa.com

Family / Familia: Dome

