

ASSEMBLY INSTRUCTIONS

INSTRUCCIONES DE ENSAMBLE

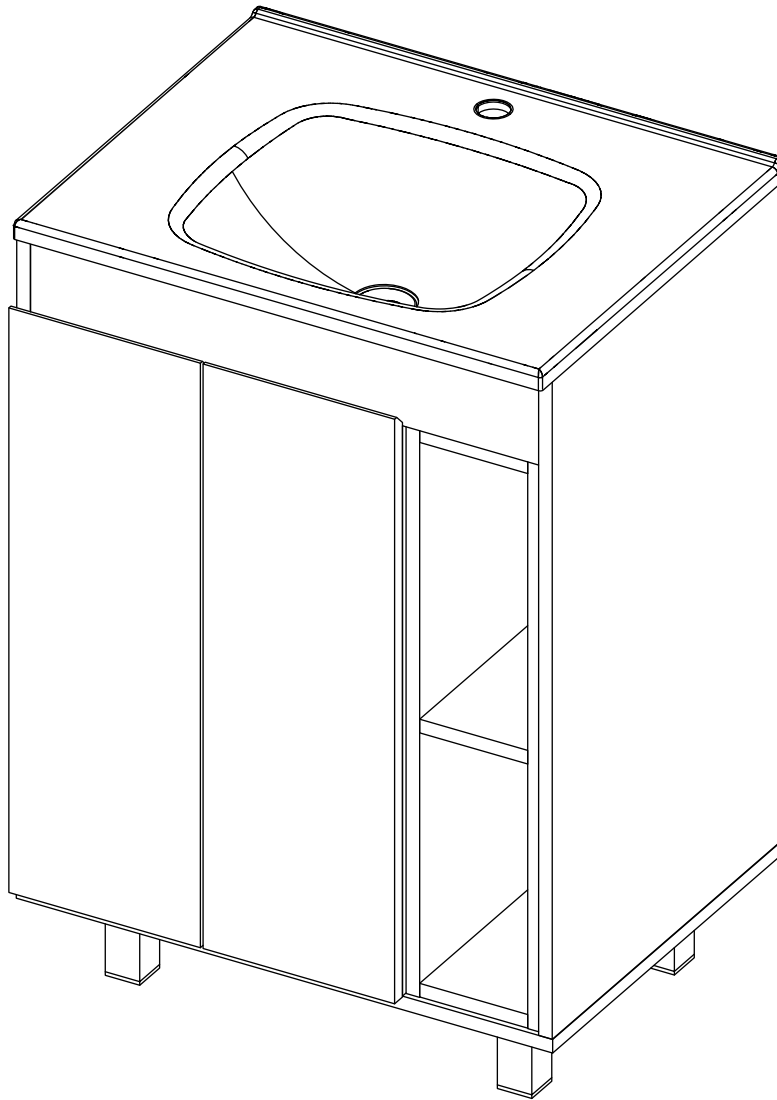

Height: 34 in
Width: 23,82 in
Depth: 17,91 in

Alto: 86,4 cm
Ancho: 60,5 cm
Fondo: 45,5 cm



IMPORTANT RECOMMENDATIONS

Do not paint the cabinet.

The cabinet **MUST** be used exclusively indoors, do not expose to direct sun.

Clean metallic hardware with a dry cloth.

Do **NOT** overload the cabinet (see suggested loads).

Do not hit or hammer the cabinet (just when indicated).

Clean with a slightly damp cloth, use gentle soaps.

Do not drag, lift and move between two people.

Avoid direct contact with water, fire or exposure to heat sources.

RECOMENDACIONES IMPORTANTES

No pintar el mueble.

El mueble debe ser usado únicamente en interiores, no exponer al sol directo.

Limpiar los herrajes metálicos con un paño seco.

NO sobrecargar el mueble (ver las cargas sugeridas).

No golpear ni martillar el mueble (solo cuando se indique).

Limpiar con un paño ligeramente húmedo, usar jabones suaves.

No arrastre el mueble, levántelo entre dos personas.

Evite el contacto directo con el agua, el fuego o la exposición a fuentes de calor.



WARNING

Never allow children to climb or manipulate the cabinet, furniture tip over can cause serious injuries or death.



ADVERTENCIA

Nunca permita que los niños escalen o manipulen el mueble, la caída de este puede provocar lesiones graves o la muerte.

INDEX

ÍNDICE

Assembly Hardware	4	Herrajes para Armado.....	4
Assembly Parts	5	Piezas de Armado.....	5
Suggested Loads.....	6	Cargas Sugeridas.....	6
Assembly Recommendations.....	6	Recomendaciones de Ensamble.....	6
Assembly Steps	7-20	Pasos de Armado.....	7-20
Warranty.....	21	Garantía	21

REQUIRED TOOLS*

HERRAMIENTAS NECESARIAS*

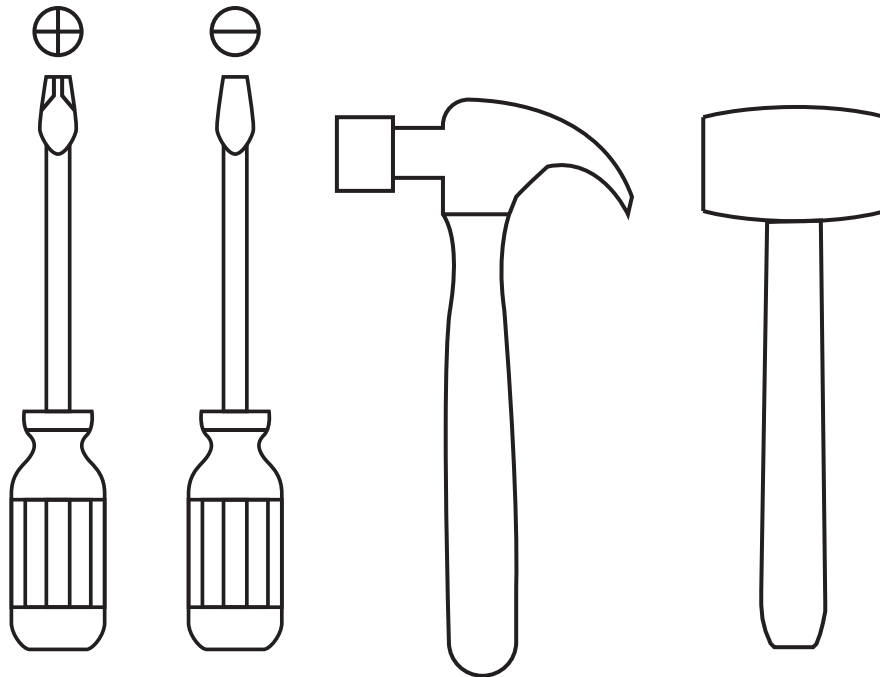

*Not included, and not shown actual size.

*No incluidas y no se muestran en tamaño real.

ASSEMBLY HARDWARE

HERRAJES PARA ARMADO

Please check that the hardware content is correct. If any item is missing, please call to our customer service line.

Compruebe que el contenido de los herrajes sea el correcto. En caso de que falte alguna pieza, por favor llame a nuestra línea de atención al cliente.

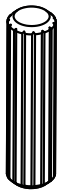

x26

Wood Dowel
Tarugo

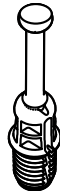

x28

Spreading Bolt
Perno Minifix



x28

Minifix Cams
Minifix



x30

Cover Caps
Tapa Adhesiva
Minifix

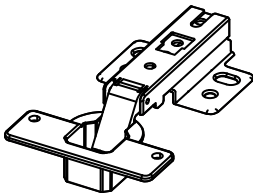

x4

Full Overlay Hinge
(Screws Included)
Bisagra Parche
(Incluye tornillos)



x24

Flat Head Screw
Tornillo Lámina

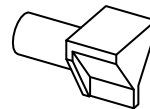

x1

Mobile Shelf
Support
Soporte Entrepáño
Movil

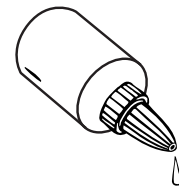

x1

Glue
Pegante

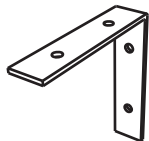

x2

Corner Brace
Platina en ángulo L
Cantonera



x2

Wall Anchor +
Drywall Screw
Chazo Mariposa +
Tornillo Ensamble

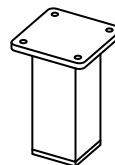

x4

Leg
Pata

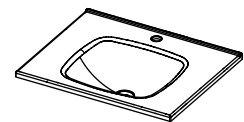

x1

Sink
Lavamanos

Hardware items are NOT shown actual size.

Los herrajes no se muestran en el tamaño real.

ASSEMBLY PARTS

PIEZAS DE ARMADO

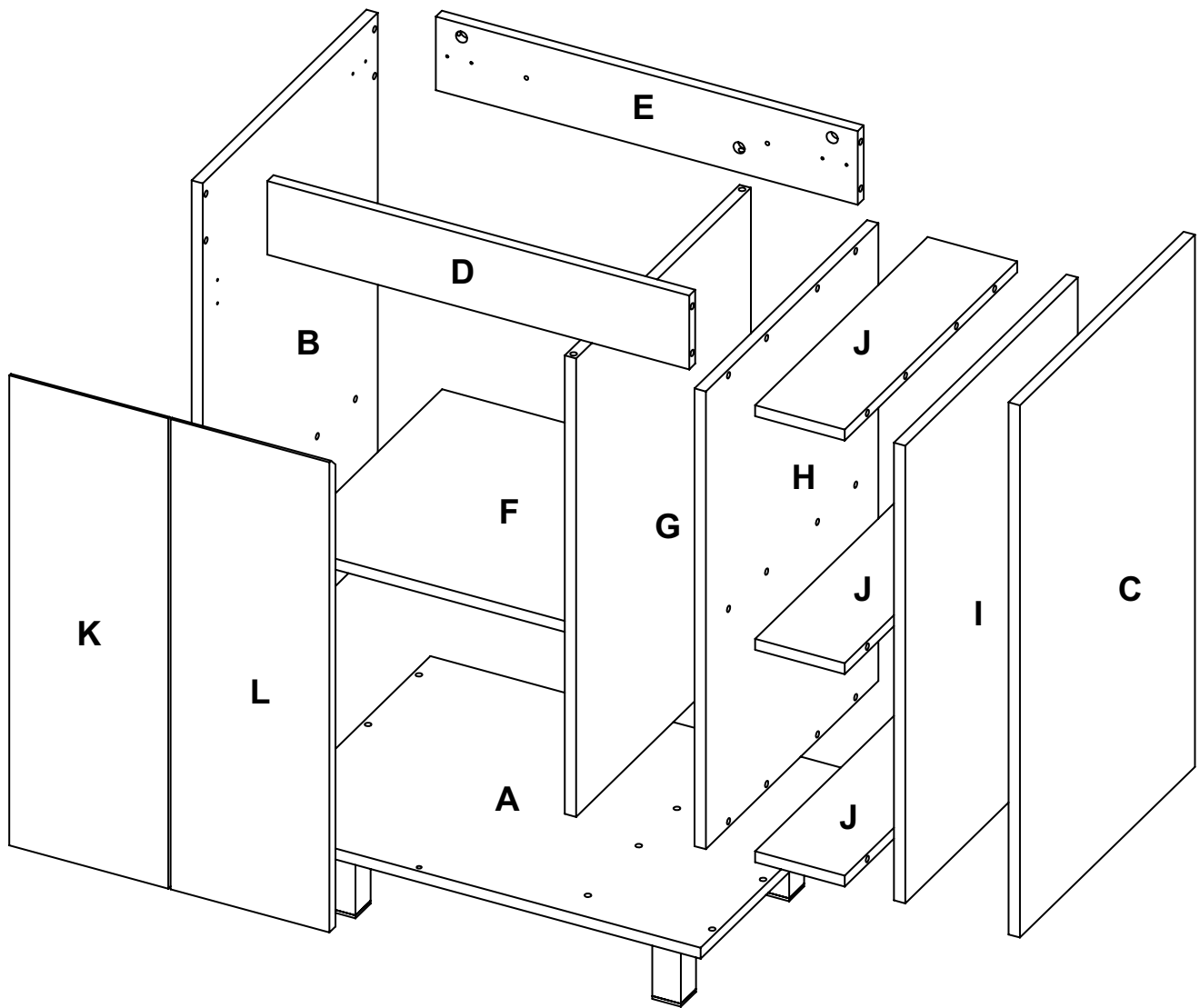

A - x1	E - x1	I - x1
B - x1	F - x1	J - x3
C - x1	G - x1	K - x1
D - x1	H - x1	L - x1

MAX SUGGESTED LOADS

CARGAS MÁXIMAS SUGERIDAS

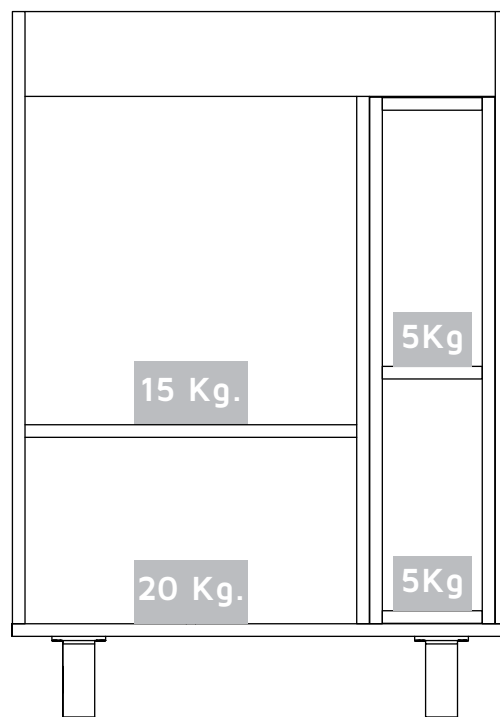
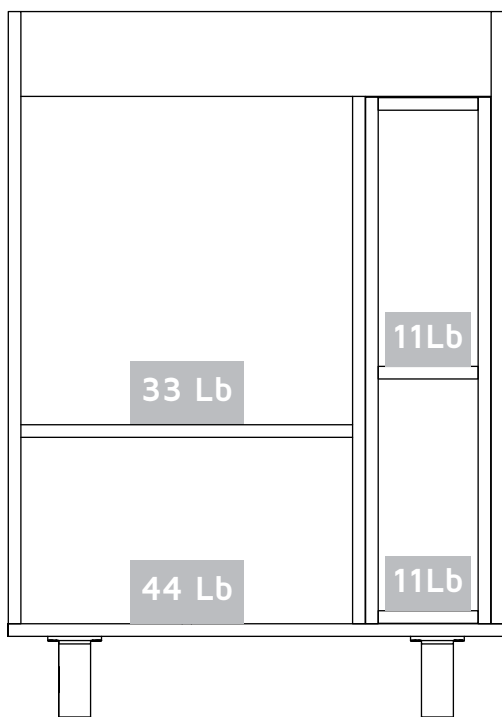

ASSEMBLY RECOMMENDATIONS

RECOMENDACIONES DE ENSAMBLE

Two people are recommended to assemble the product.

Ensamble el mueble entre dos personas.

Assemble the cabinet on a flat, smooth surface, preferably on a carpeted floor or the carton box of the product.

Ensamble el mueble sobre una superficie plana y lisa, preferiblemente sobre un tapete o el cartón de la caja

Carefully read the assembly instructions and identify every wood and hardware part before start assembling the cabinet.

Lea cuidadosamente las instrucciones e identifique todas las piezas y herrajes antes de empezar a armar el mueble.

1

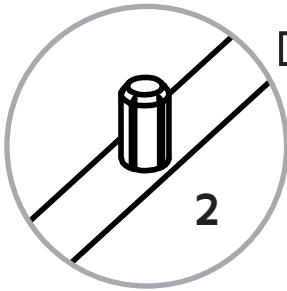
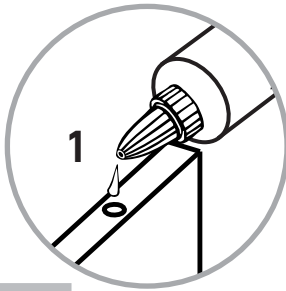
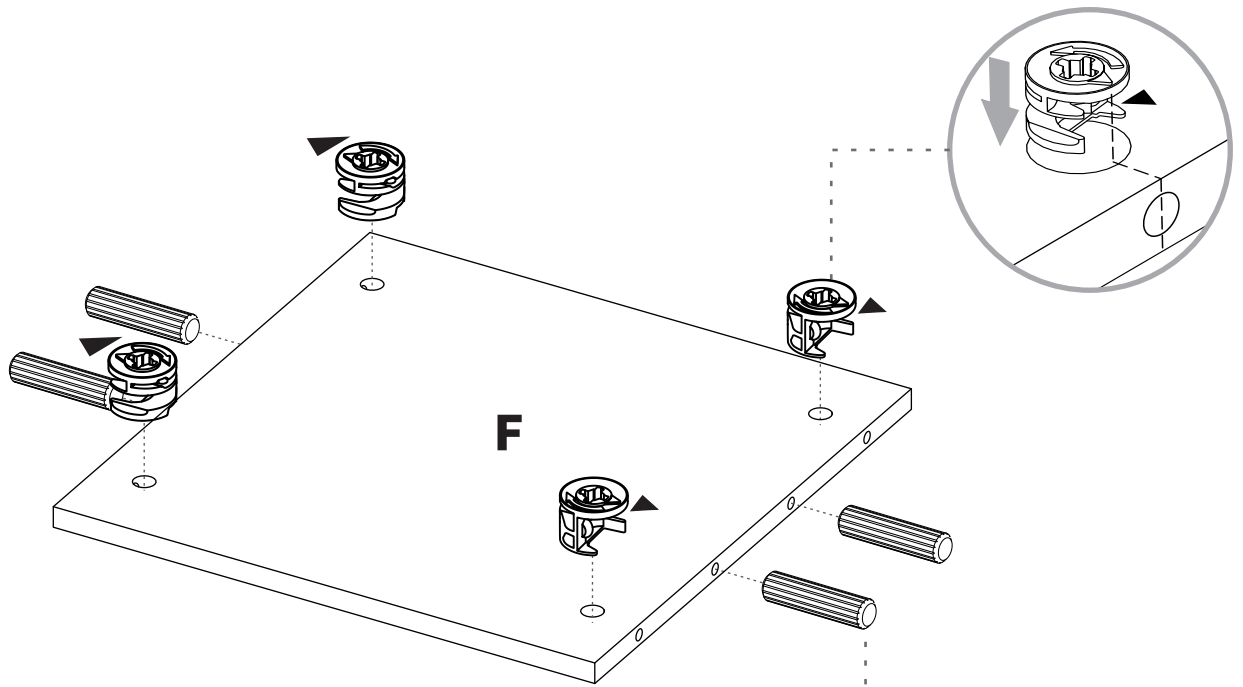

2

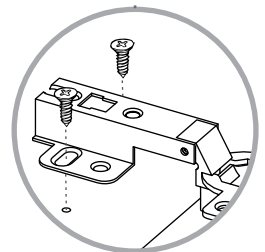
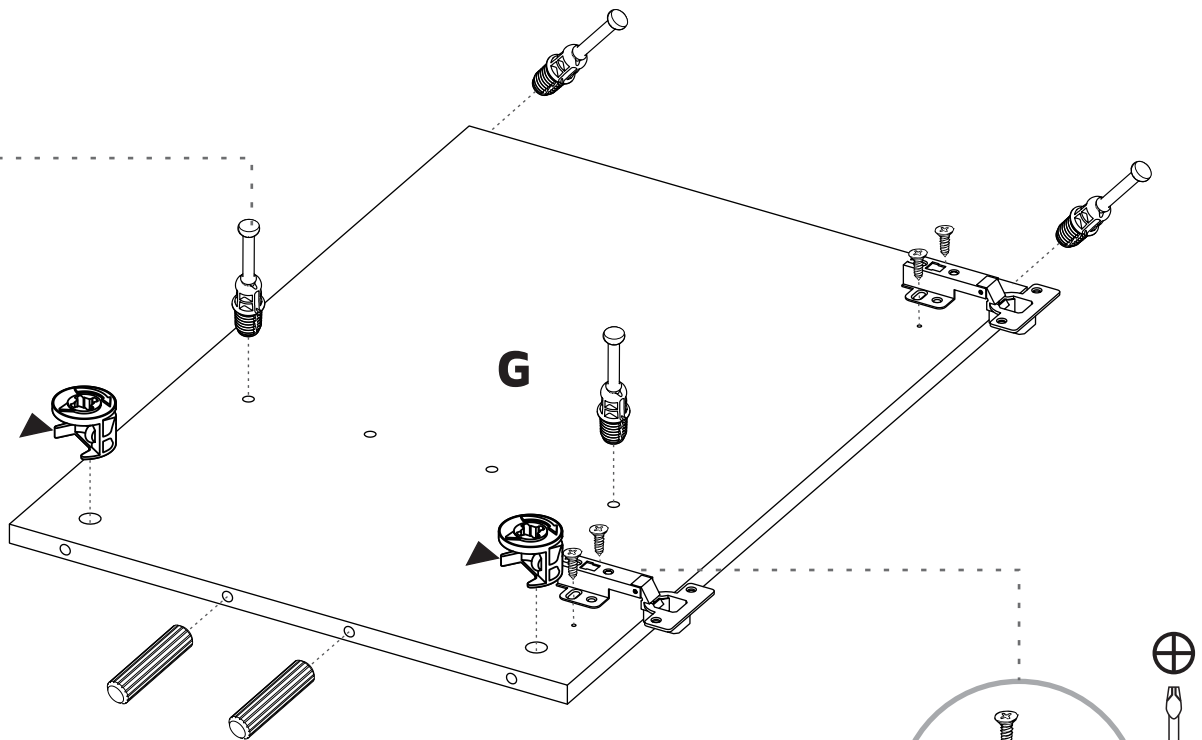

3

Turn minifix cams to the right to tighten.
Gire las cajas minifix hacia la derecha
para apretar las piezas.

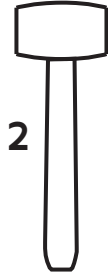

Gently hit the pieces
with a rubber hammer
to adjust the joint.
Golpee suavemente la
pieza con un martillo
de goma para ajustar
el ensamble.

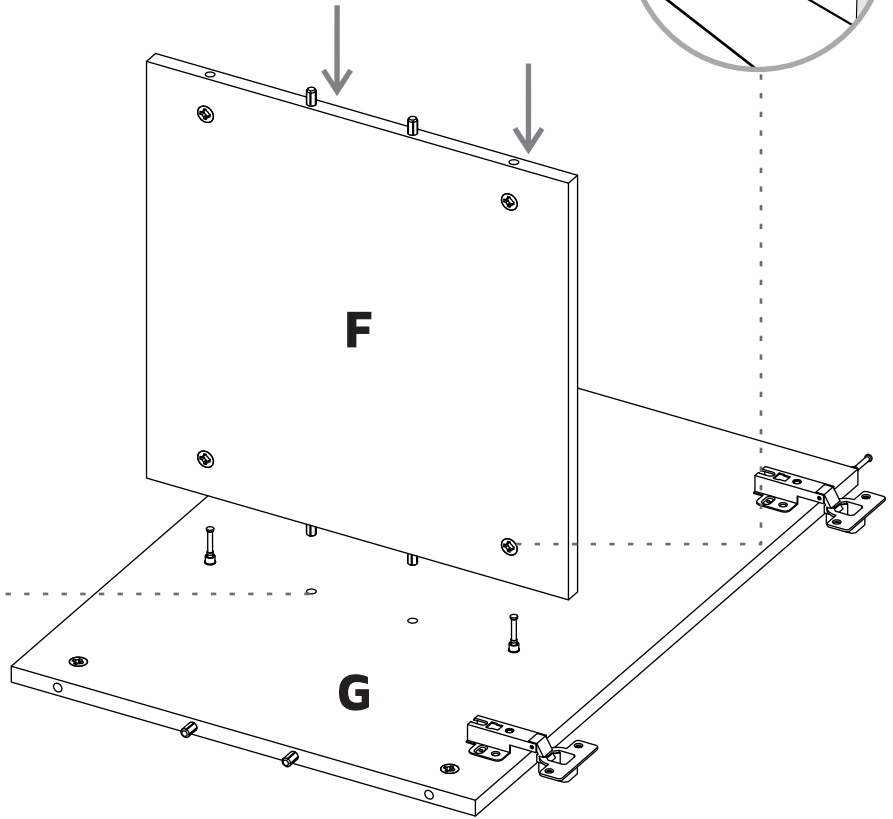
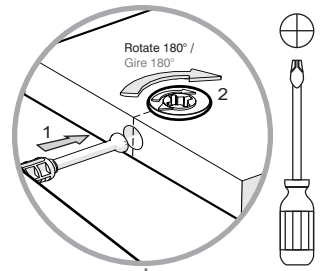

4

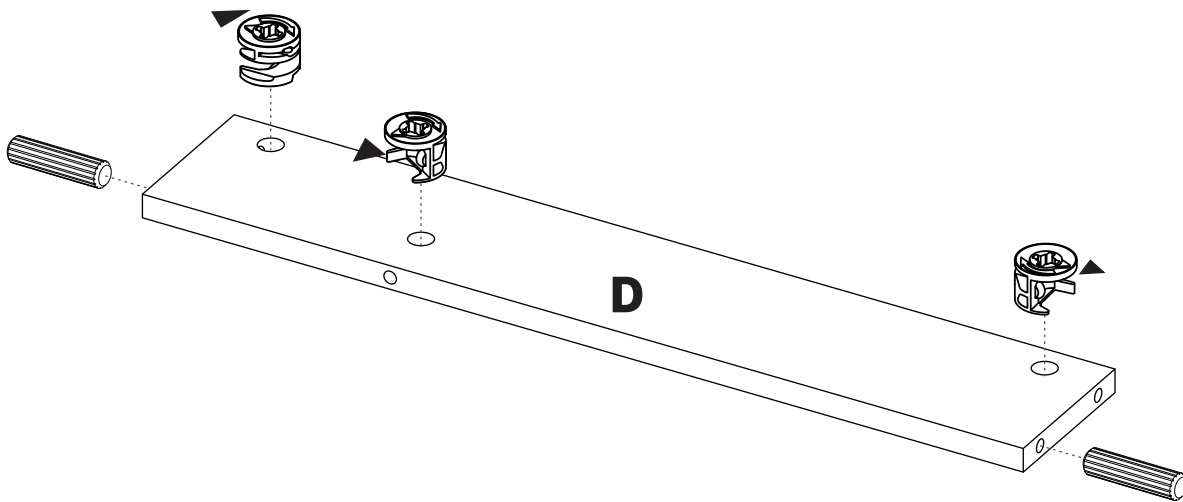

5

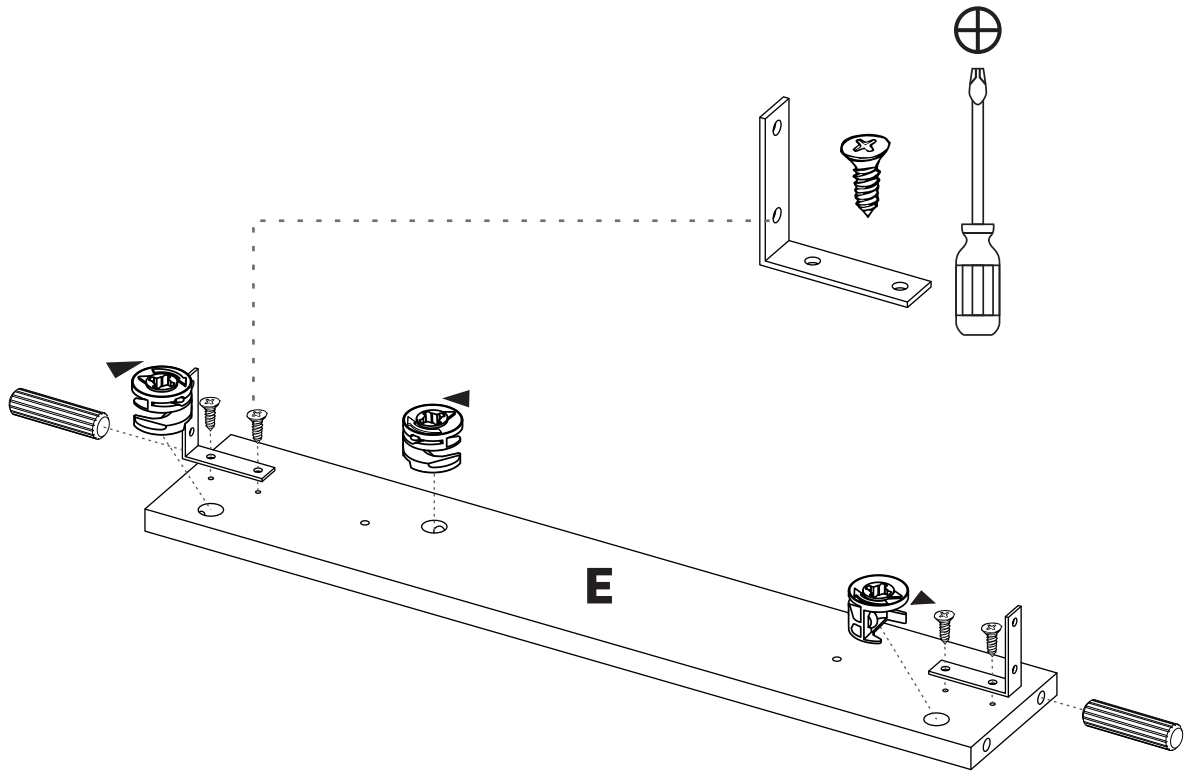

6

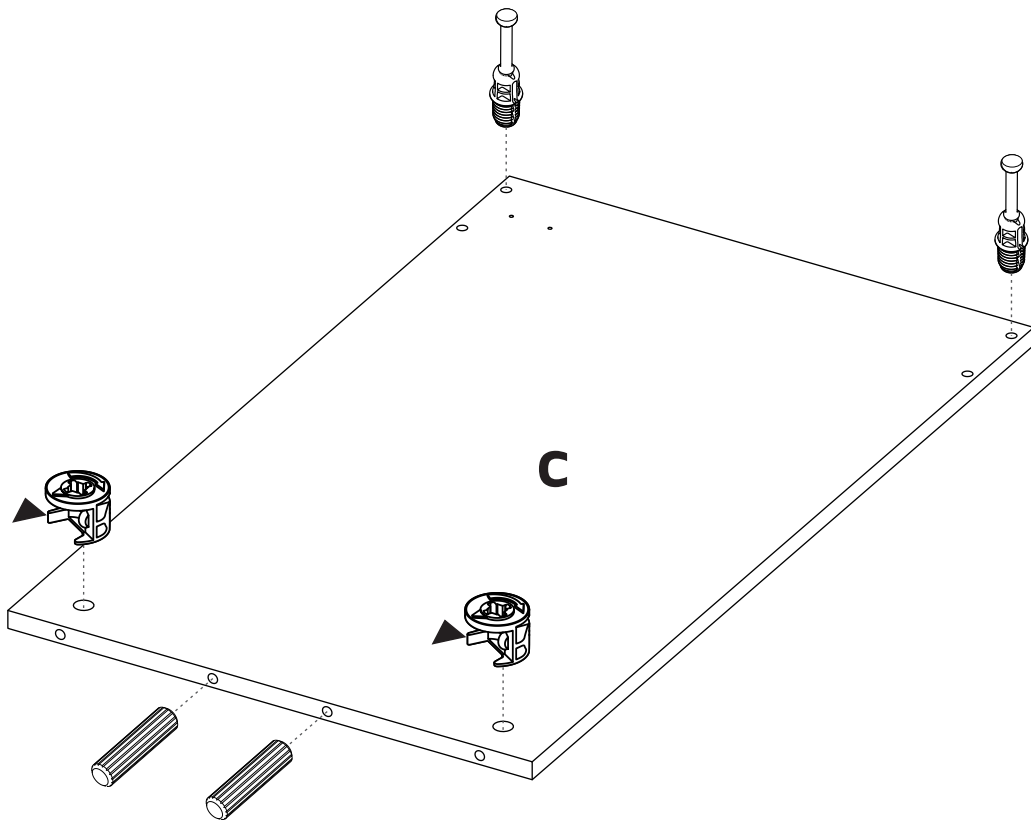

7

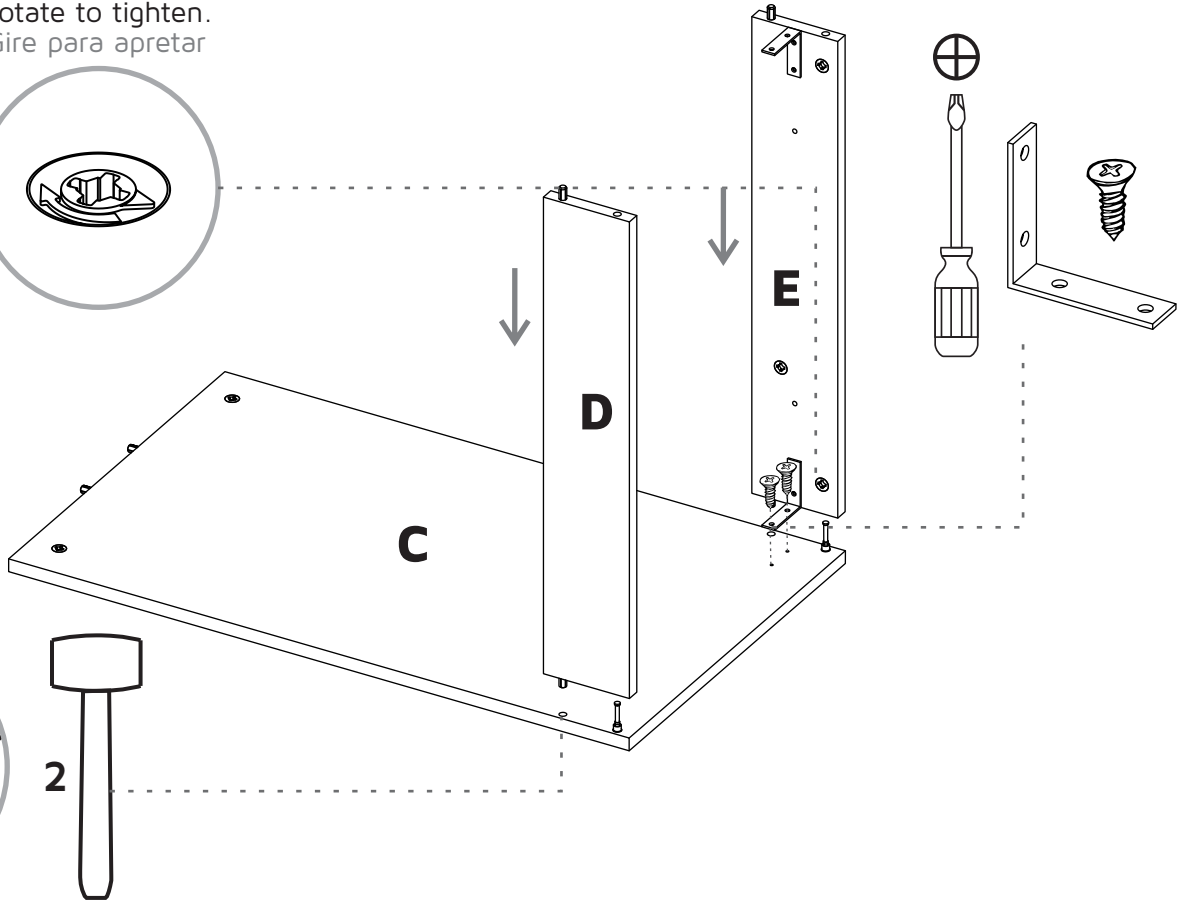

8

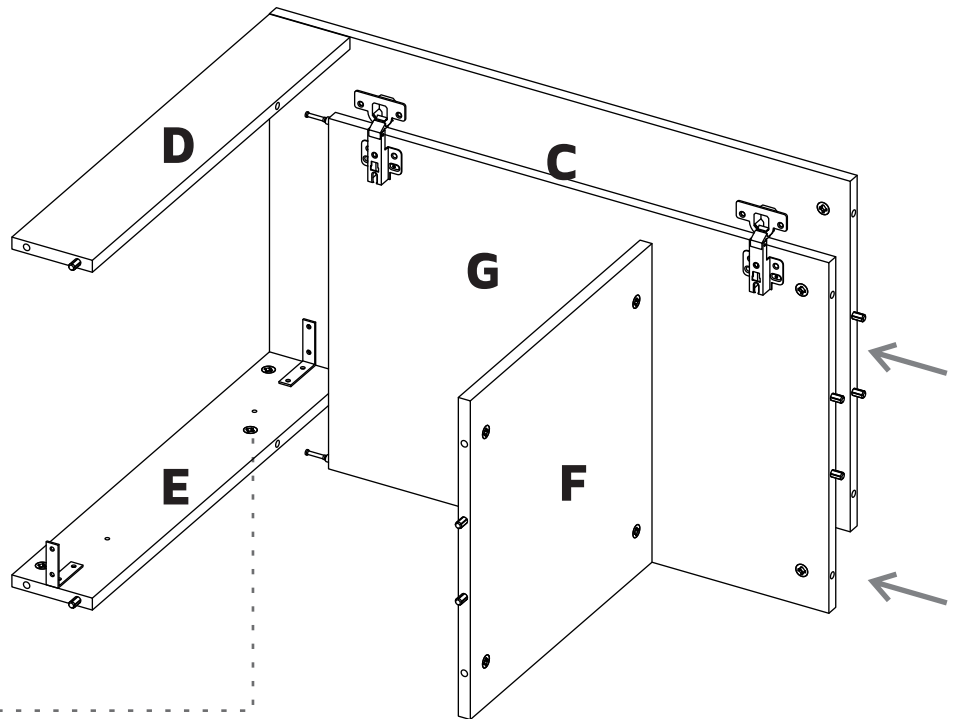
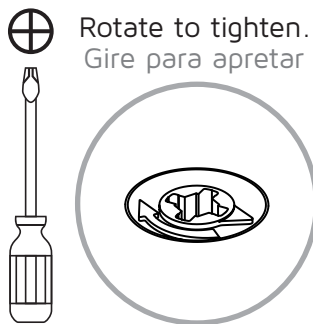

9

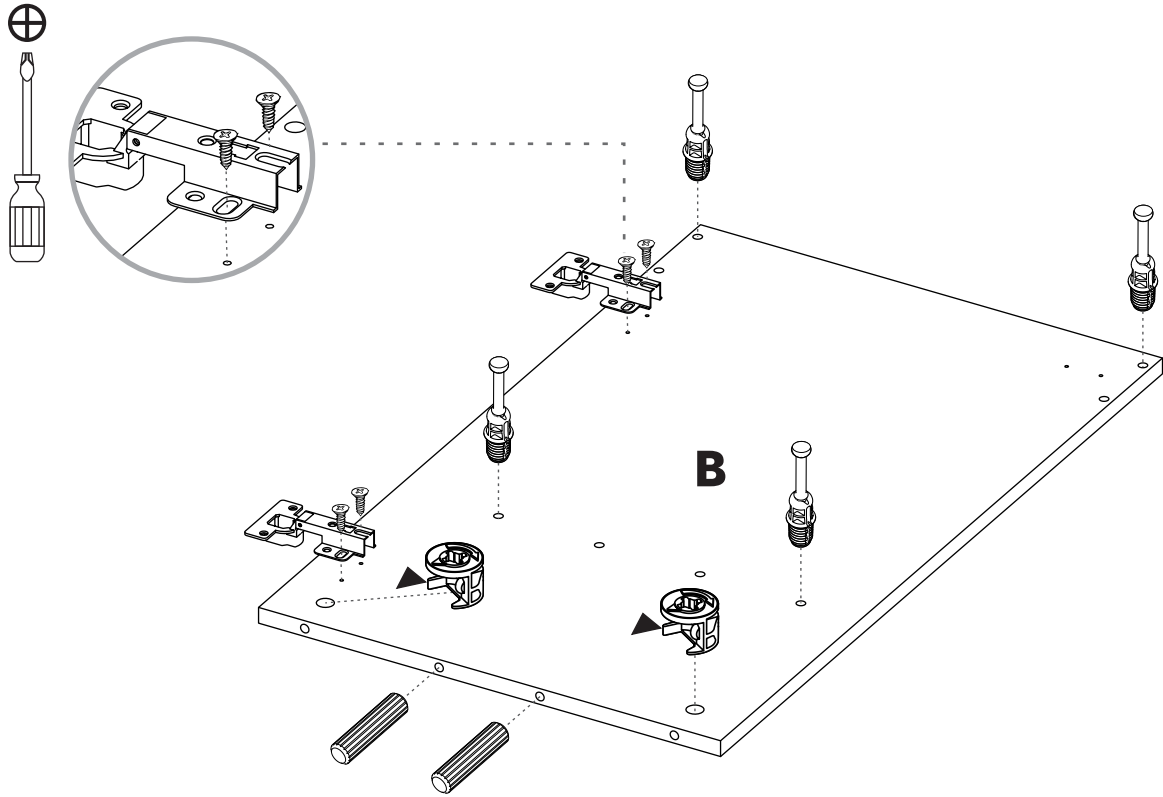

10

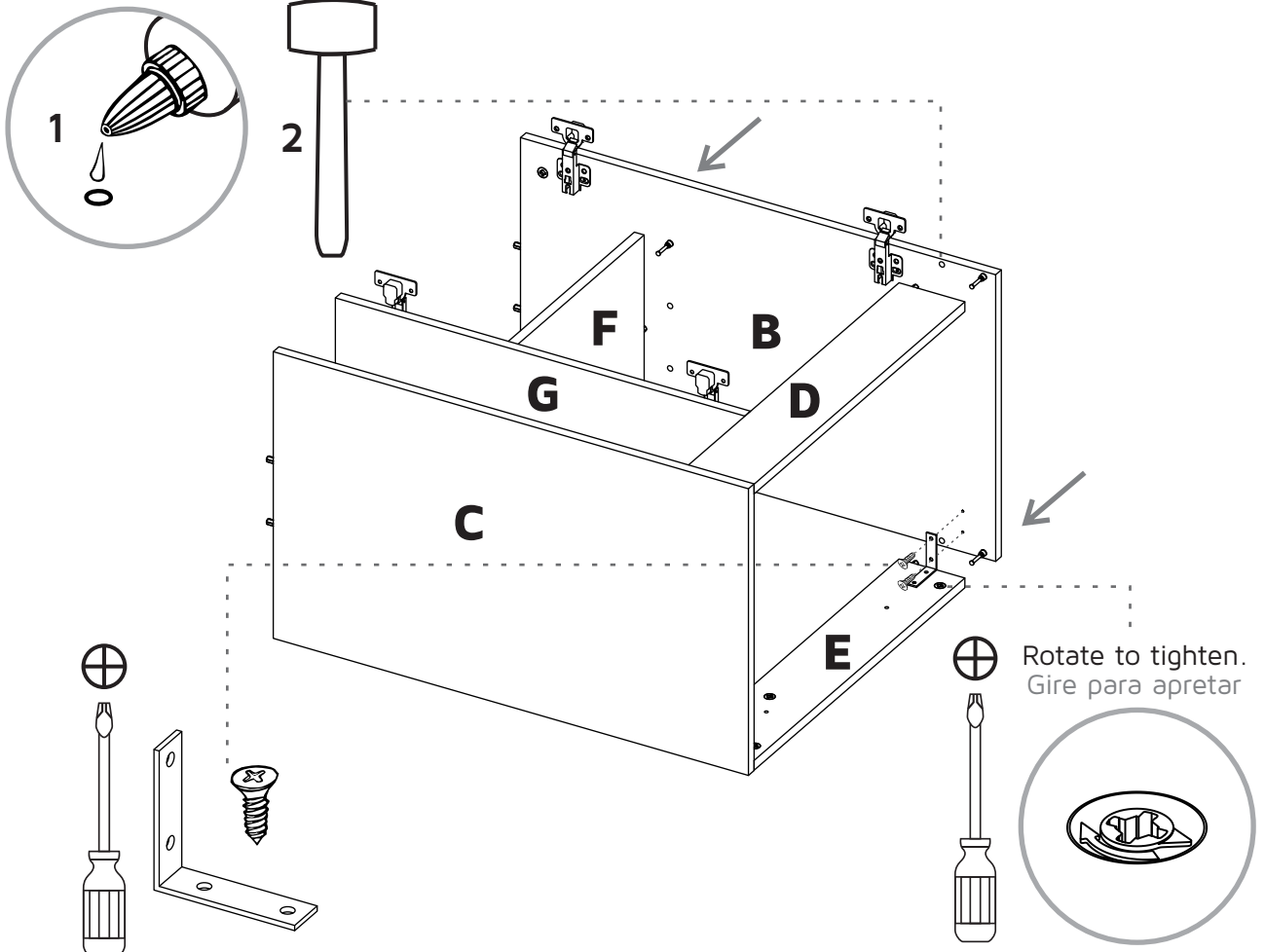

11

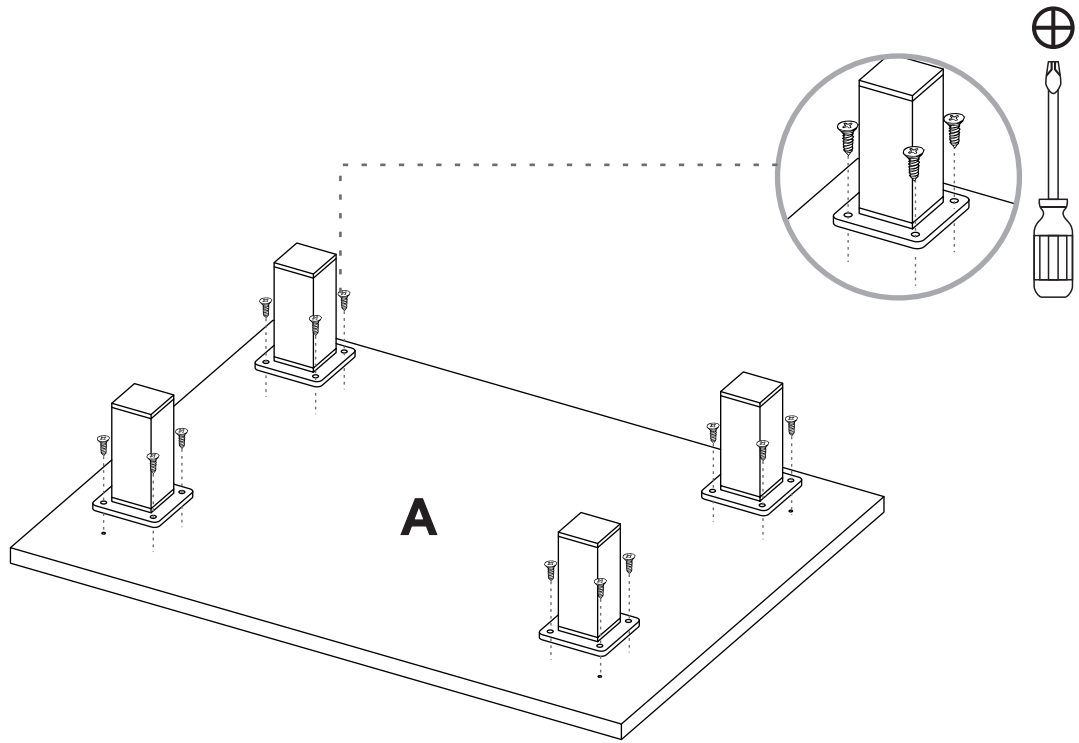

12

Turn Over
Volver

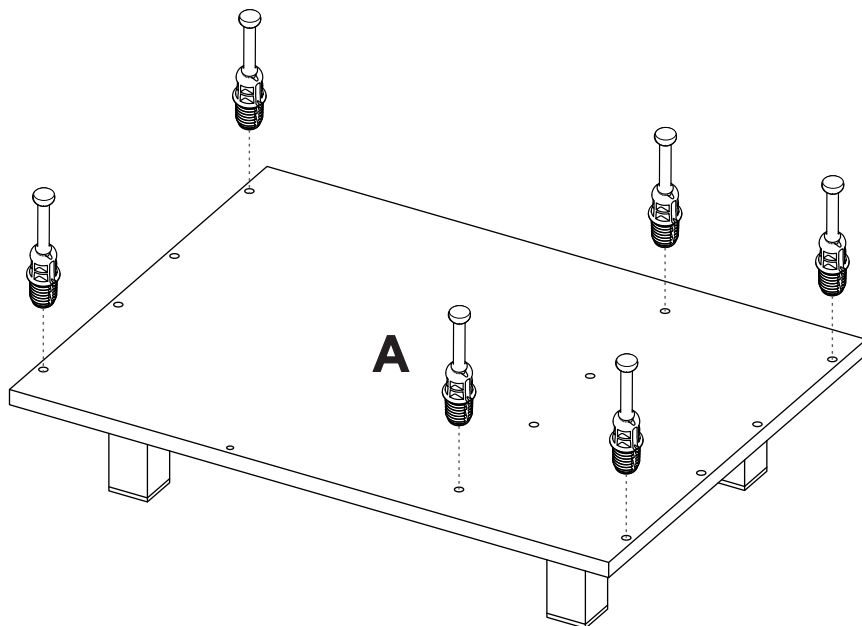

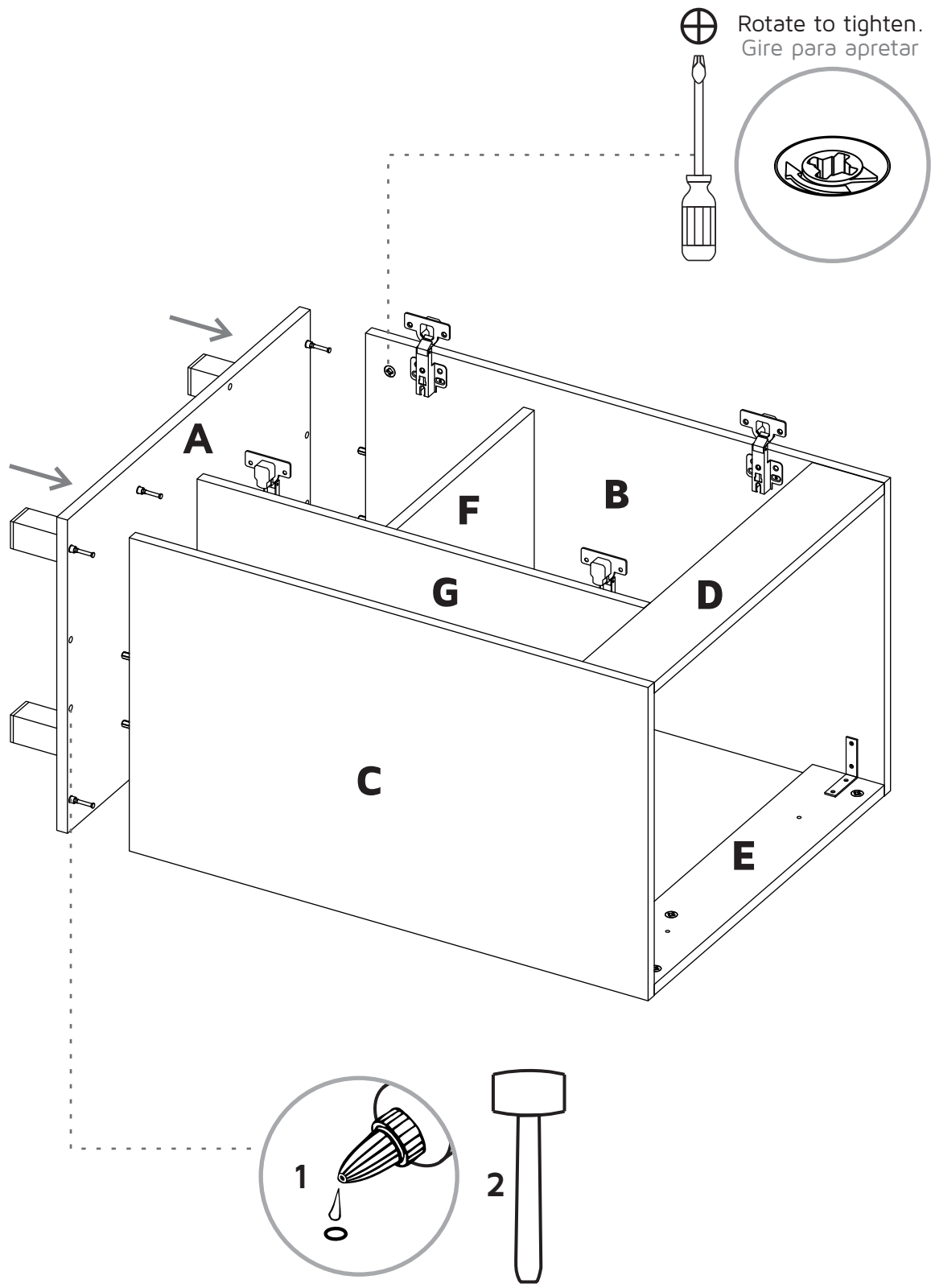

15

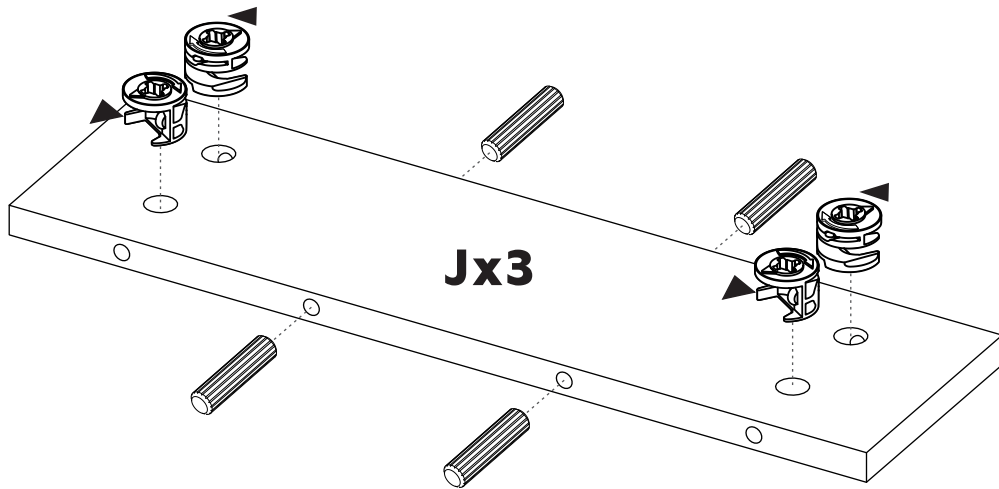

16

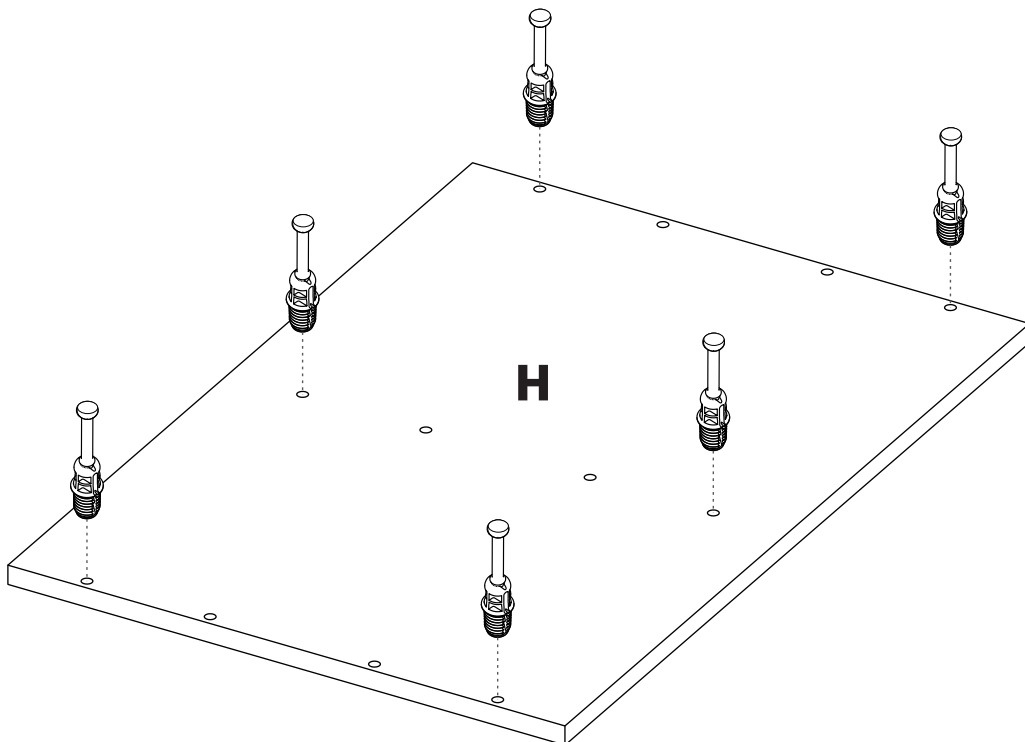

17

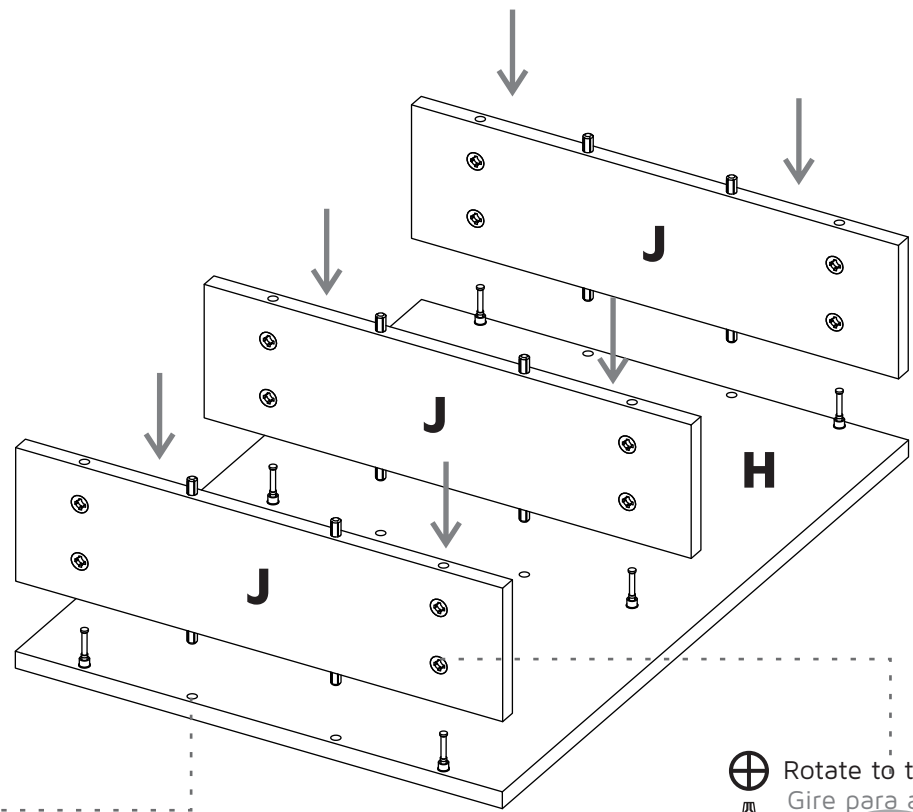

18

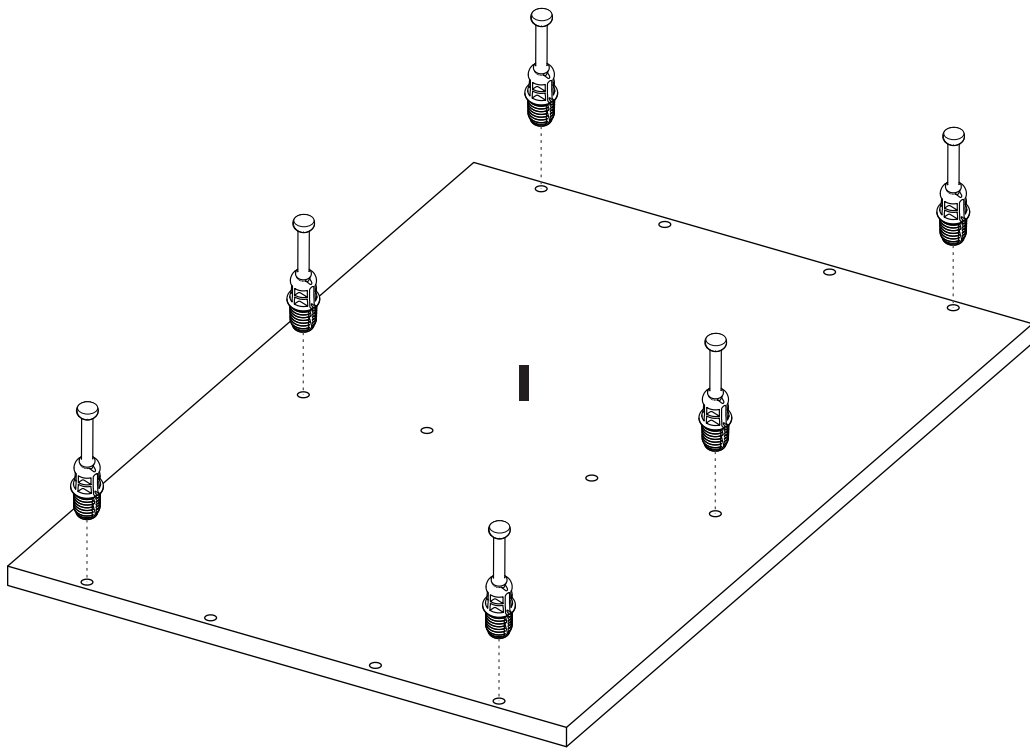

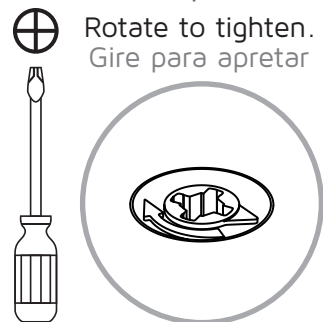
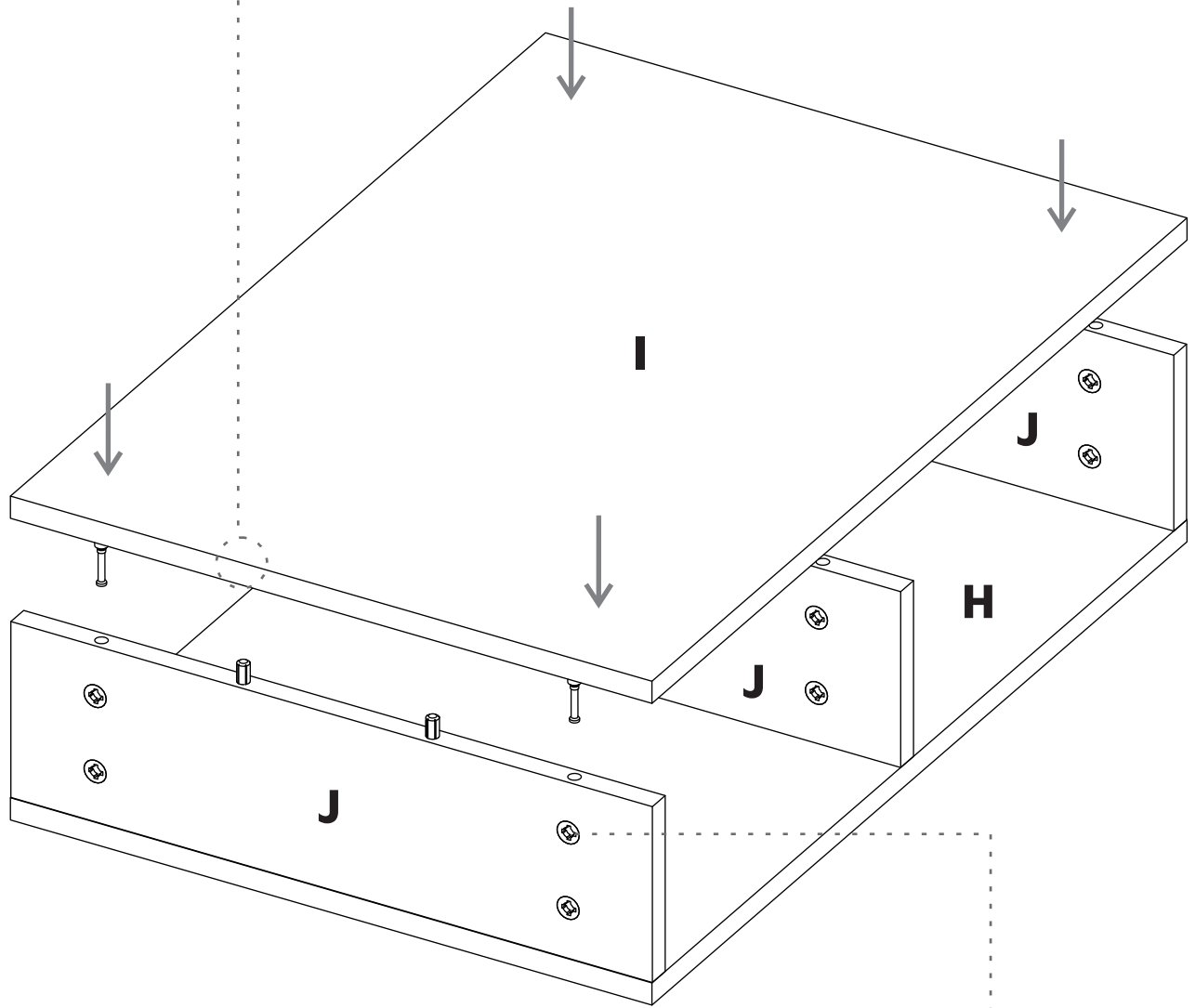
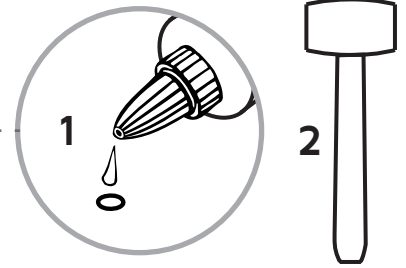

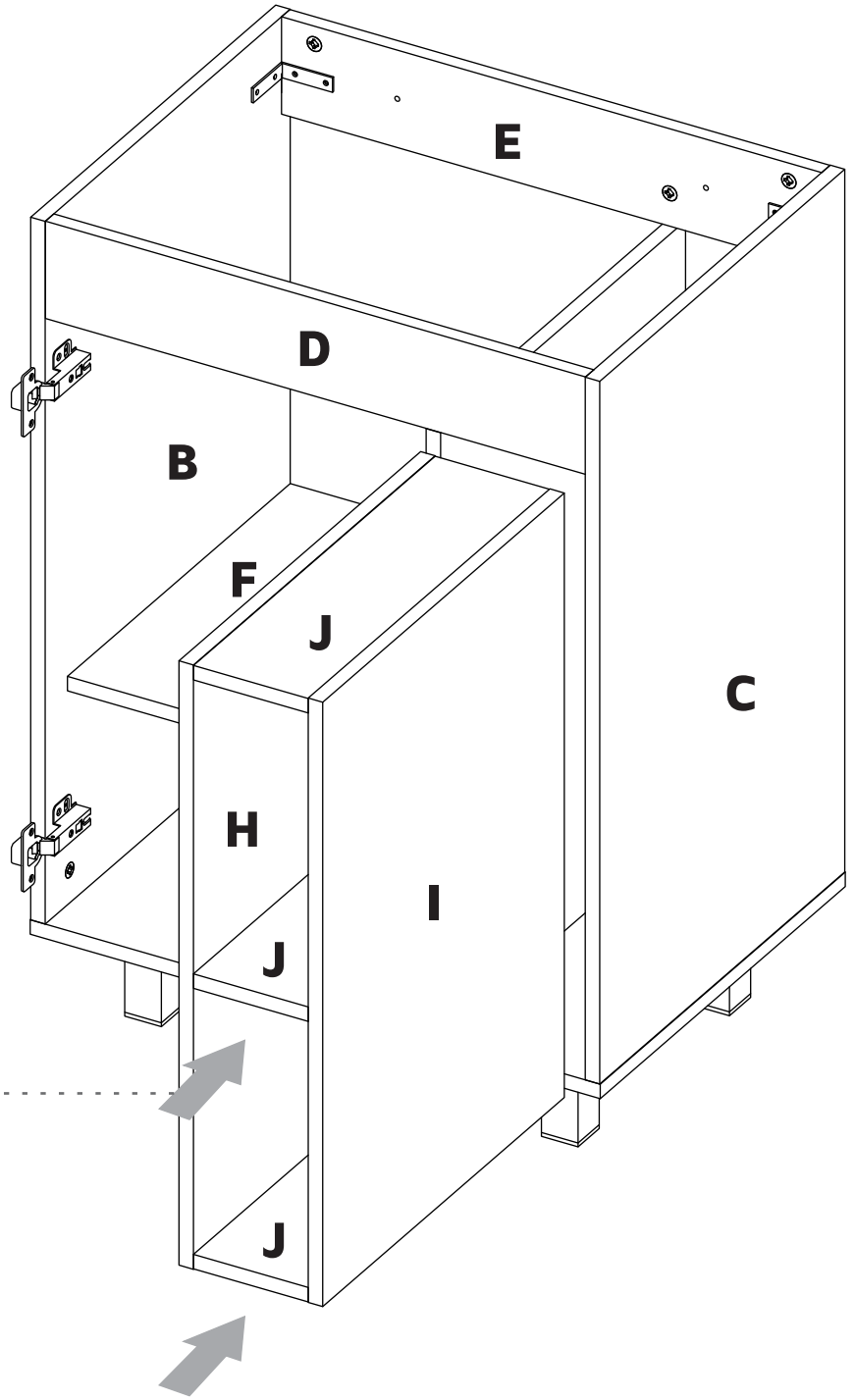

Slide inside
the cabinet
Deslice dentro
del mueble

21

Door Installation Instalación de las Puertas

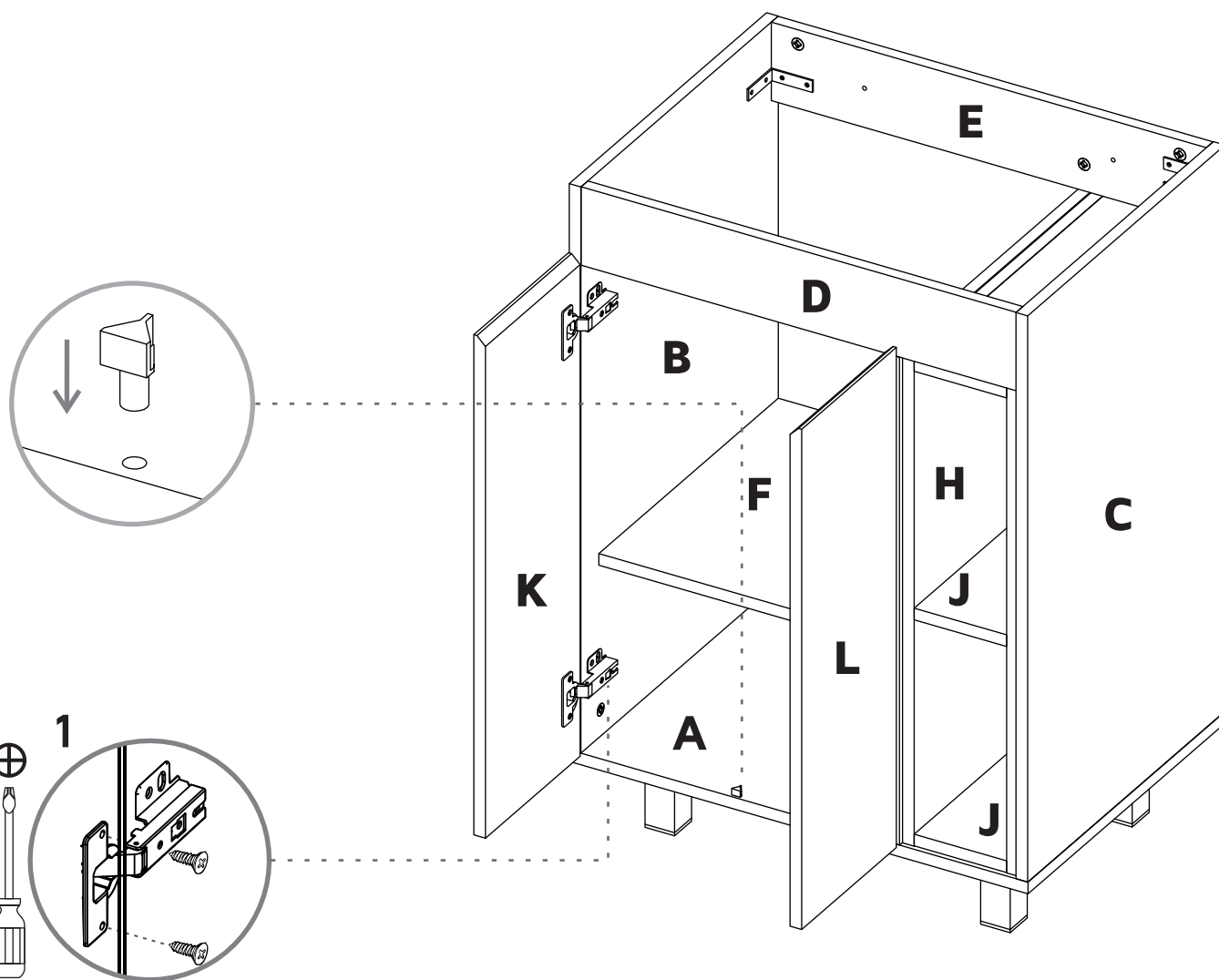

Hinge adjustment Ajuste de las bisagras

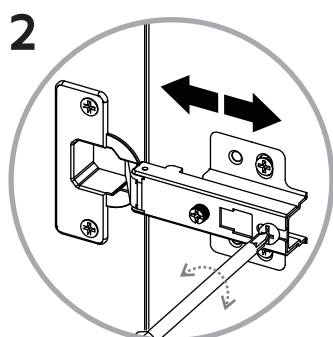

Depth adjustment
Ajuste de profundidad

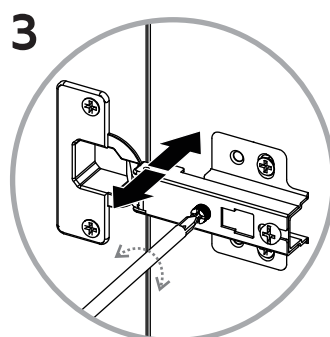

Side adjustment
Ajuste lateral

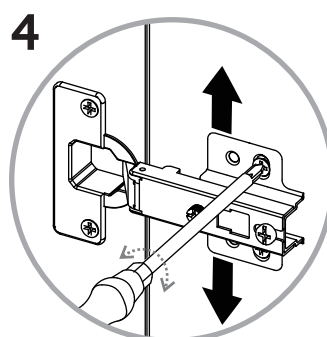

Height adjustment
Ajuste de altura

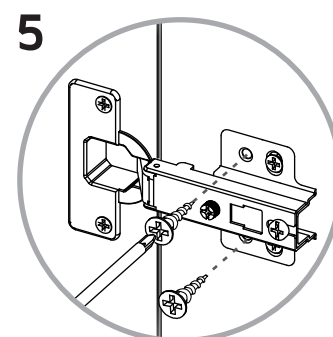

22

Sink Installation Instalación de lavamanos

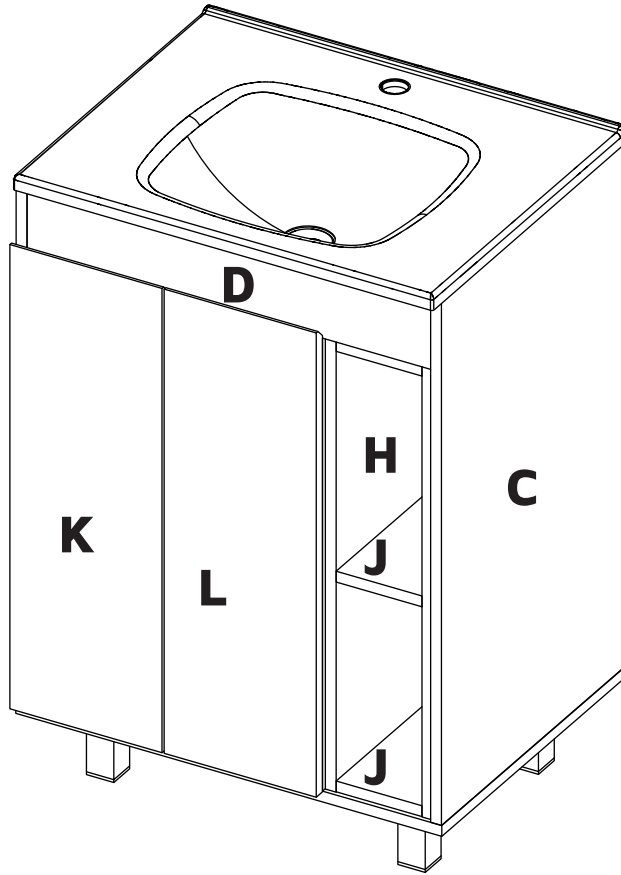

Tenga en cuenta la aplicación de silicona para asegurar el lavamanos al mueble, como se muestra a continuación: / Keep in mind to apply silicone to install the sink, as is explained below:

1. Limpie la superficie superior del mueble para eliminar la suciedad.

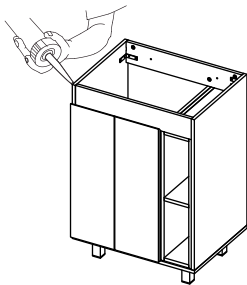

Clean the top and apply silicone

2. Ubique el lavamanos en el mueble

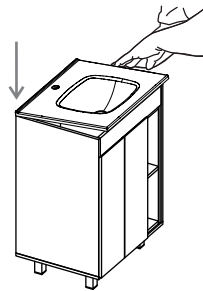

Place the sink on the vanity unit

3. Aplique una línea delgada de silicona alrededor de todos los bordes.

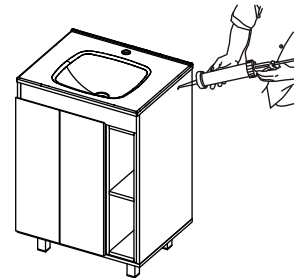

Apply silicone on the edges

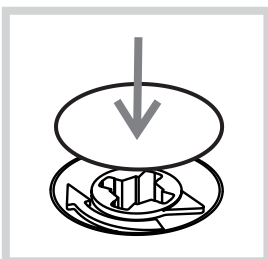

After you finish the adjustment of the cams, cover them with the cover caps.

Después de ajustar todas las cajas minifix, cúbralas con las tapas adhesivas.

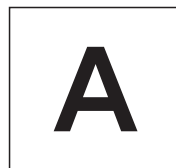

After you finish assembling the cabinet, take off the adhesive letters.

Al terminar de armar, desprenda las letras adhesivas.

WARRANTY POLICY

PÓLIZA DE GARANTÍA

A 2 year warranty coverage in wooden parts and 1 year warranty coverage in hardware pieces since its manufacturing date, which you can see in the lot number printed on the product box and the assembly instructions leaflet.

Warranty covers materials and workmanship imperfections which impair the assembly or correct functioning of the cabinet.

This warranty is not valid if the defects or imperfections are caused by the incorrect following of the assembly instructions, warnings and recommendations, misuse, intentional damage, fire or flood, or after modifications or any kind of alteration, or repaired by someone not authorized, when it's been assembled 3 months after the date of purchase. These defects MUST be reported before the warranty coverage period ends. Once the product has been assembled, the company will not be responsible for defective and/or damaged parts.

This warranty is ONLY valid for the ORIGINAL PURCHASER, it doesn't apply if the product has been resold, rented, etc.

No liability for incidental or consequential damages caused to or by the product (This may not apply in your state).

To make this warranty valid you must write to our customer service email describing the product defect, lot number and submitting your sales receipt or proof of purchase, or contact us at our customer service line. Replaced parts will be under the product's original warranty coverage period. Damaged parts will become property of the company.

There are no other warranties applicable to this product.

**IF ANY PARTS ARE BROKEN OR
MISSING PLEASE CONTACT US**