

ASSEMBLY INSTRUCTIONS

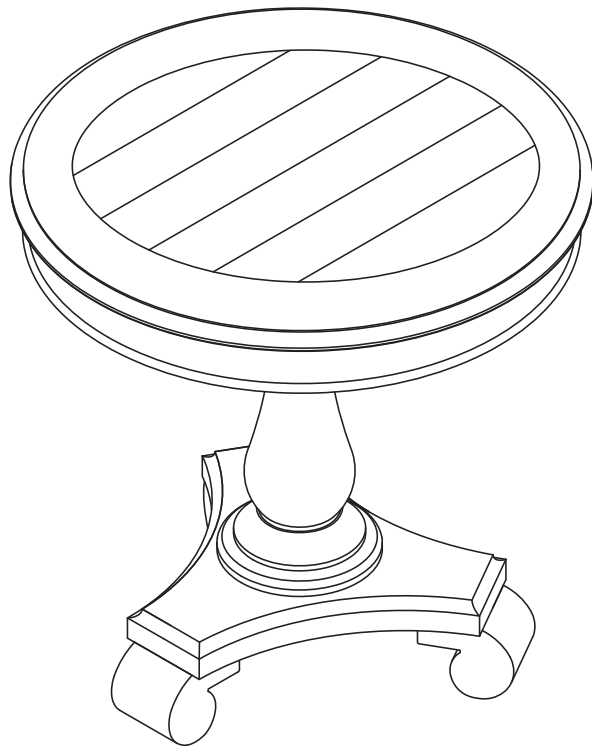

PARTS LIST

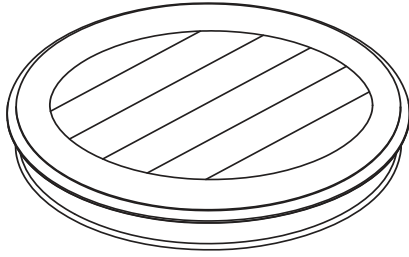

(1) Top Panel (1 PC)

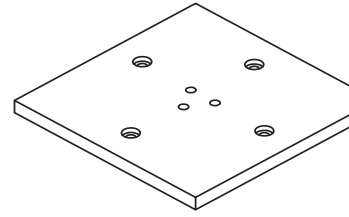

(2) Connection Panel (1 PC)

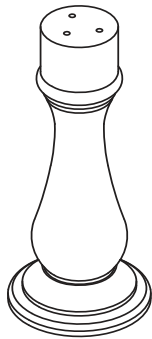

(3) Post (1 PC)

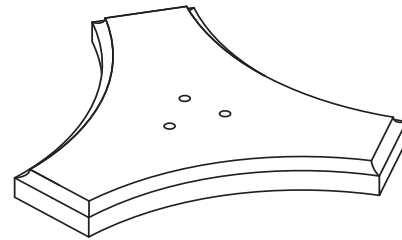



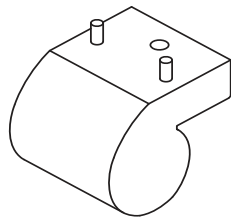

(4) Base Panel (1 PC)



(5) Foot Pad (3 PCS)

HARDWARE LIST

NO	SKETCH	DESCRIPTION	SIZE	QTY
A		BOLT	$\phi 5/16'' * 35\text{mm}$	10PCS
B		FLAT WASHER	$\phi 5/16'' * 35\text{mm}$	13PCS
C		LOCK WASHER	$\phi 5/16'' * 35\text{mm}$	13PCS
D		ALLEN KEY	4mm	1PC
E		BOLT	$\phi 5/16'' * 45\text{mm}$	3PCS

STEP 1:

Attach Connection Panel (2) to Post (3) using three Flat Washers (B), three Spring Washers (C) and three Bolts (A).
TIGHTEN ALL BOLTS USING WRENCH (D).

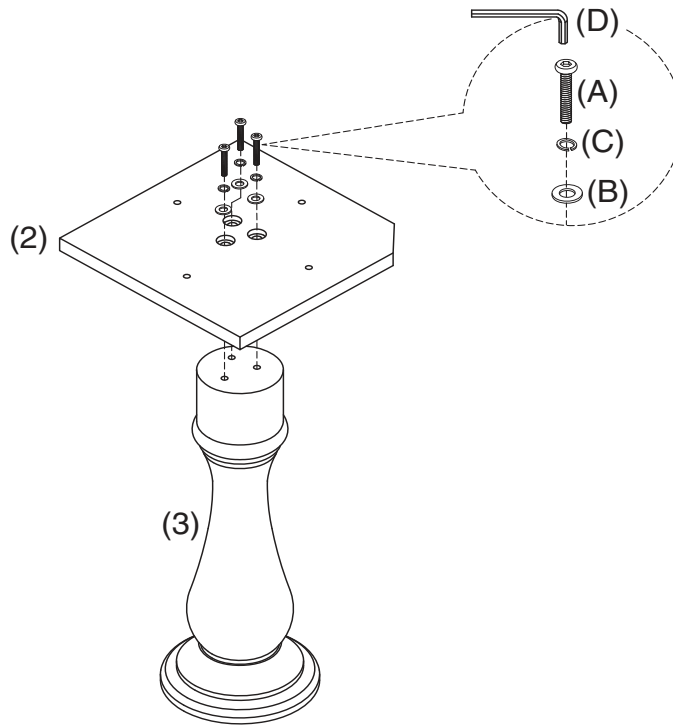

STEP 2:

Attach Connection Panel (2) to Top Panel (1) using four Flat Washers (B), four Spring Washers (C) and four Bolts (A).
TIGHTEN ALL BOLTS USING WRENCH (D).

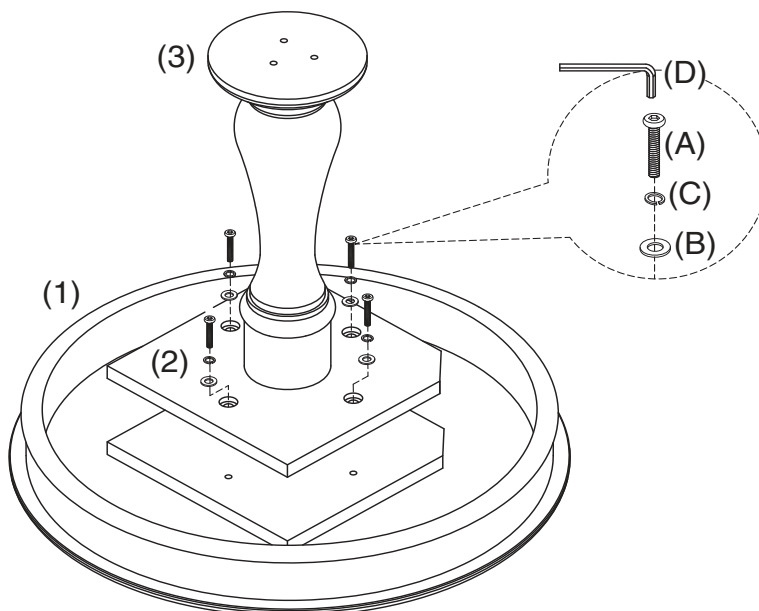

STEP 3:

Attach Base Panel (4) to Post (3) using three Flat Washers (B), three Spring Washers (C) and three Bolts (A) TIGHTEN ALL BOLTS USING WRENCH (D).

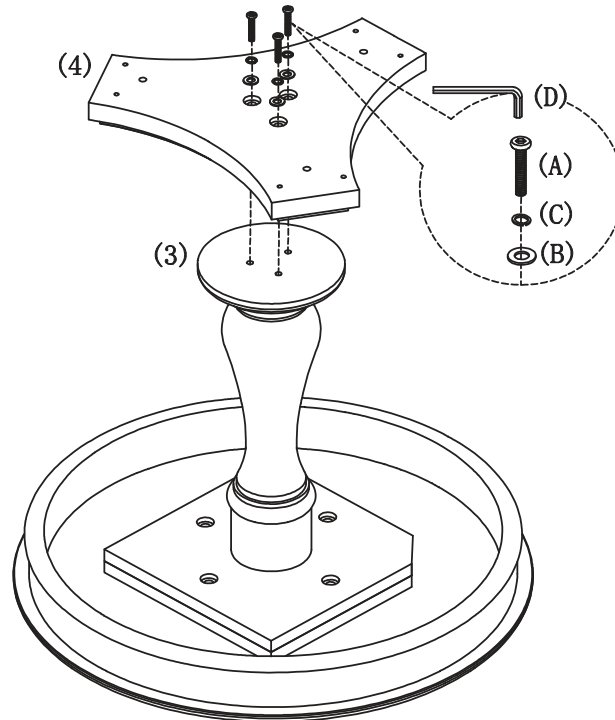

STEP 4:

Attach Foot Pads (5) to Base Panel (4) using one Flat Washer (B), one Spring Washer (C) and one Bolt (E) for each Foot Pad (5) TIGHTEN ALL BOLTS USING WRENCH (D).

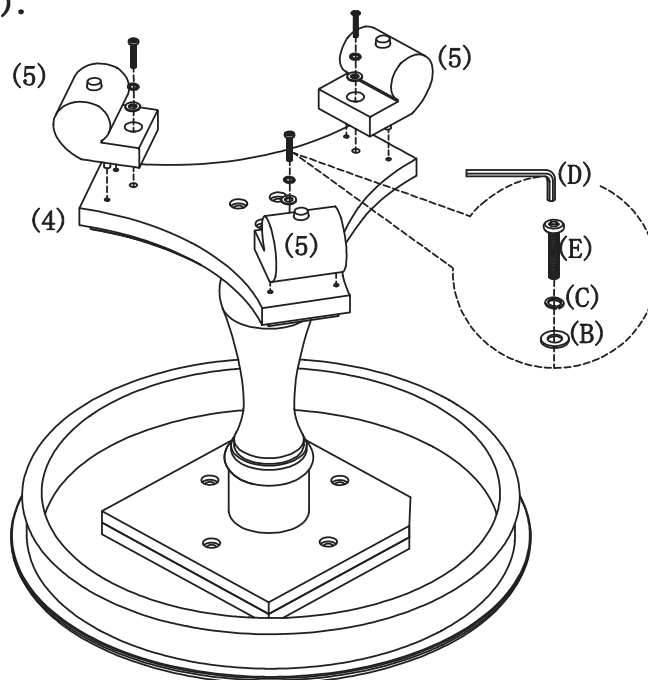

IMPORTANT: MAKE SURE BOLTS ARE SECURELY TIGHTENED BEFORE USING THIS PRODUCT.

STEP 5:

Adjust levelers to level table.

