

Metal Swing Set

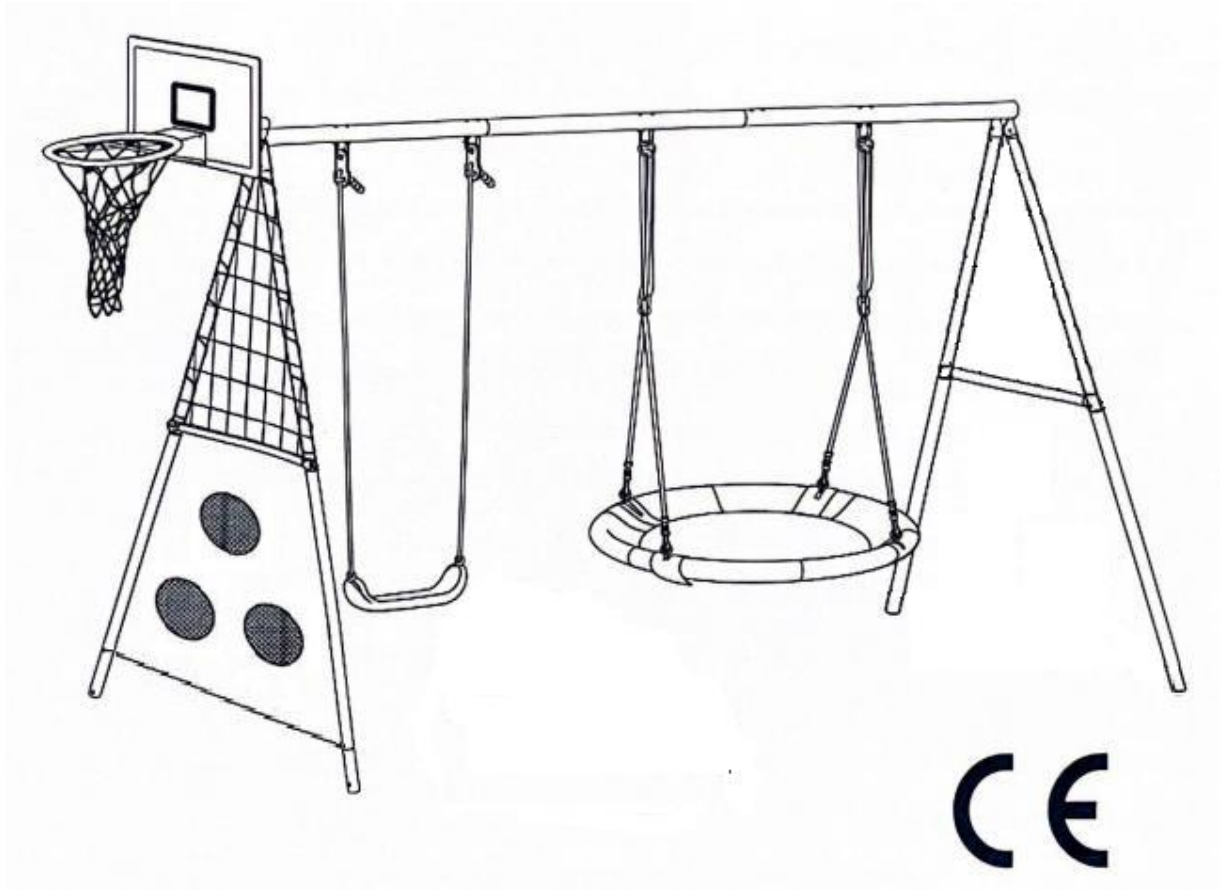

User Manual

Warning

- Please read the user manual and warnings carefully before using the swing set.
- Assembly of the swing set requires two adults.
- The swing set is designed for use by up to 5 children aged 3 to 8 simultaneously.
- Do not use the swing set on hard soil, concrete or other hard surfaces.
- The maximum weight per user is 70kg/154lbs, and total weight of all children must not exceed 140kg/308.64lbs.
- Ensure the swing set is securely fixed to the base.
- Please keep this user manual for future reference.

Dear Customers

Please carefully read and understand these instructions, as they contain detailed guidance and warnings that must be followed to prevent accidents and damage.

1. This swing set is intended for use solely on private property and not for commercial purposes. The warranty does not extend to commercial use of the swing.
2. This product is intended for children aged 3 to 8 years old. The swing set should only be used after it has been assembled and safety-checked by an adult. Children should play under adult supervision at all times. Children under 6 years old should not be near the swing during installation as small parts may be swallowed accidentally and pose a choking hazard.
3. Installation must be carried out on level ground. Any unevenness on the floor should be corrected prior to installation. Installing the swing on sloped or uneven terrain may result in joint stress, potentially leading to serious injury. Ensure that the swing set is positioned at least 2 meters away from other objects such as electrical equipment, buildings, walls, trees, etc.
4. It is recommended to use cushioning material around the swing set to minimize the risk of injuries to children in case of falls. Grass surfaces do not provide sufficient protection against serious physical injuries. Lay down a protective surface within a radius of two meters around the installed swing set.
5. It is prohibited to play in windy or rainy weather. It is recommended to secure the product to the ground. This prevents the unit components from shifting and ensures stability.
6. The swing set should be inspected before each use and undergo regular maintenance. While maintenance can safeguard the swing set, it cannot entirely eliminate the risk of damage. Therefore, it is important to routinely check for signs of damage such as excessive wear or loose parts. If the product is found to be damaged or broken, cease using it immediately, and restrict children's access to the swing set until repairs are completed.

Important Information

Before Use

- Please review the user manual carefully before starting to assemble and use the swing set.
- Assembly of this swing set should be performed by adults ONLY. The use of work gloves during assembly may be necessary to prevent injury.
- Children should be kept away from the installation site.
- Upon receiving the product, carefully unpack all parts and compare them with the attached list to ensure that all components are present. If any parts are missing, do not proceed with assembly.

Please contact the seller for assistance.

- Do not attach longer ropes to the swing. The ropes included in the swing set are of appropriate length to ensure safe use of the swing.

Installation Site

- Clear the ground of any objects that may pose a threat to a child's safety and health in the event of a fall, such as tree roots, tree trunks, stones, sprinklers, etc. Avoid installing the swing set in areas with electrical or water supply lines.
- Do not install the swing set on hard surfaces such as asphalt, concrete, paving slabs, or other brick surfaces.
- Falls on hard surfaces can result in physical injury or even death in children. The following list outlines recommended surfaces for installing swings:
 - A. Double layers of shredded bark mulch (20cm/7.9in thick).
 - B. Uniform wood chips (30cm/11.8in thick).
 - C. Fine gravel (30cm/11.8in thick).
 - D. Fine sand (30cm/11.8in thick).

Weather Conditions

- Do not use the swing set if the seat or any other part is wet. Only use it when clean and dry. Wet surfaces may increase the risk of slipping from the swing set.
- Pay attention to weather conditions when using the swing set. In case of strong winds, the child may lose balance and encounter accidents, especially in particularly hazardous weather conditions such as strong winds, storms, tornadoes, etc. In such situations, it is advisable to disassemble the device and store it in a safe place.

Cautions

- The swing set is designed for children aged 3 to 8 years old.
- Children should ONLY use the swing set under the supervision of an adult who is familiar with the hazards and warnings outlined in this user manual.
- The swing set must be securely fixed to the ground.
- The packaging and aluminum foil are not toys. Please keep them out of reach of children to prevent the risk of swallowing and suffocation.
- Do not allow more than one child to use the swing at a time.
- Do not allow your child to stand on the swing seat.
- Do not allow your child to get too close to the swing when other children are using it. Always maintain a safe distance to avoid collisions with children on the swing.
- Do not allow your child to twist the swing rope as this may weaken the rope, leading to faster wear and potentially causing an accident.
- Do not swing on an empty swing. Swinging swings may pose a threat to nearby children.
- Ensure your child sits in the center of the swing seat to evenly distribute the weight.
- Do not jump off the swing while swinging. Always wait until the swing comes to a complete stop before getting off.
- Always dress children in appropriate clothing for outdoor play and ensure they are not wearing accessories such as jewelry or scarves that could get caught in swing elements and cause an

accident.

- Do not allow your children to climb on the ropes or other parts of the swing set. The frame of the structure is not intended for play.
- Keep pets away from the swing when children are playing.
- Do not use the swing set if screws or nuts are missing or loose. Always check the safety condition of your swing set before use.
- Regularly remove stones, sharp objects, and other debris from around the swing set that may pose a threat to your child's health and safety in the event of a fall.
- Steel and plastic parts are suitable for use in mild weather. The rate of wear for materials depends on exposure to UV rays, air pollution, and other weather conditions such as rain or wind. Structures should be regularly inspected for signs of wear, cracks, loose components, and overall condition. If any of these defects are noticed, cease using the swing set until the issues are addressed and the damage is repaired.

Fixed To The Ground

- There are various methods to secure a swing to the ground, depending on the type of ground it's installed on. Ensure that all nails are driven below the surface to prevent tripping hazards.
- Remember to install the nails on a hard, flat surface before securing the area around the swing set with fall protection material.
- The most effective method to attach a swing is the "corkscrew" method. Ensure that the swing frame is level with the ground. Screw the nails into the ground until only the hook remains above the surface, positioned near the frame leg. Insert the hook into the hole in the frame leg and screw it securely into the ground.

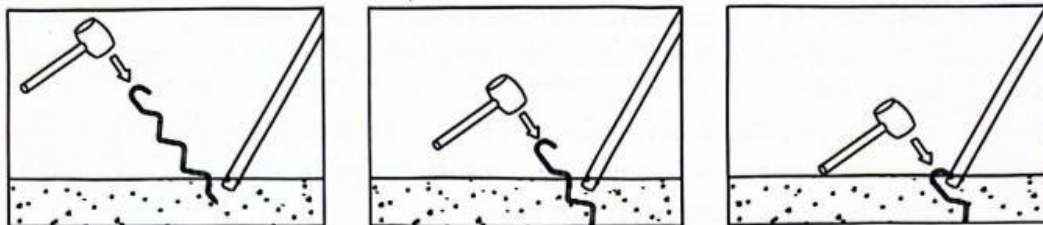

Routine Maintenance

Before Playing:

- Tighten all screws.
- Lubricate all moving metal parts.
- Check all moving parts (including the swing seat) for rust and replace them if corrosion is found.
- Reinstall all plastic parts that were removed during the winter, such as seats and other elements.

Twice a Month:

- Tighten the screws,
- Check all other installation parts (pipes, nails, netting, swing hooks).

Once a Month:

- Lubricate all metal moving parts.
- Check all moving parts (including the swing seat) for rust and replace them if corrosion is found.

After Playing:

- When the temperature is below 0°C, it's advisable to disassemble the swing and store it in a dry indoor location to protect it from adverse weather conditions.











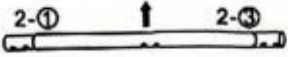

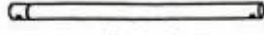

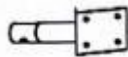



Tighten the Screws and Nuts





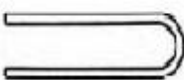

















- Tighten the screws until you feel the "first resistance." Over-tightening the screws may cause the structure to loosen, leading to potential accidents.
- After assembly is complete, double-check that all screws, nuts, and other parts are securely installed and tightened. Do not allow children to begin playing until the assembly has been inspected. However, refrain from climbing on the frame structure.

Disposal Instructions

- When you no longer require the swing set or if it no longer serves its purpose due to technical reasons, it's essential to carefully dismantle the structure. Consider wearing protective work gloves to prevent injury.
- Before starting to dismantle structural parts, ensure that disassembled components are kept away from children.
- Recycle disassembled parts by taking them to appropriate metal and plastic waste collection points.
- Any rusted items should be disposed of and not reused.

Swing Set Parts

<p>1 - x1</p> 	<p>2-x1 (hole)</p> 	<p>3 - x1</p> 
<p>4 - x4 yellow</p> 	<p>5 - x3 blue</p>  <p>5a - x1 blue (hole)</p> 	<p>6 - x2</p> 
<p>7 - x1</p> 	<p>8 - x1</p> 	<p>9 - x1</p> 
<p>10 - x4</p> 	<p>11 - x2</p> 	<p>12 - x1</p> 
<p>13 - i x1</p> 	<p>14 - x1</p> 	<p>15 - x3</p> 
<p>16 - x1</p> 	<p>17 - x1</p> 	<p>18 - x4</p> 
<p>19 - x1</p> 	<p>20 - x1</p> 	<p>21 - x1</p> 

<p>A -</p>  <p>x4 (M8 x 67)</p>	<p>B -</p>  <p>x4 (M8 x 70)</p>	<p>C -</p>  <p>x4 (M8 x 25)</p>
<p>D -</p>  <p>x1 (M8 x 20)</p>	<p>E -</p>  <p>x5 (M8 x 114)</p>	<p>F -</p>  <p>x15 (Φ8.5 x Φ19mm)</p>
<p>G -</p>  <p>x23 (Φ8.5 x Φ13mm)</p>	<p>H -</p>  <p>x12 (Φ8.5 x Φ19mm)</p>	<p>I -</p>  <p>x22 (M8)</p>
<p>J -</p>  <p>x18 (M8)</p>	<p>N -</p>  <p>x2 (M6x115)</p>	<p>L1 -</p>  <p>x1 (M8)</p>
<p>L1 -</p>  <p>x1 (13mm)</p>	<p>L2 -</p>  <p>x4 (M6x60)</p>	<p>K -</p>  <p>x28 (Φ6.5 x Φ13mm)</p>
<p>M -</p>  <p>x1 (M6)</p>	<p>M -</p>  <p>x1 (10mm)</p>	<p>W -</p>  <p>x12 (M6)</p>
<p>S -</p>  <p>x2 (M6x50)</p>	<p>X -</p>  <p>x6 (M6x40)</p>	<p>Y -</p>  <p>x2 (M6x15)</p>
<p>Z -</p>  <p>x2</p>		

Assembly and Installation Instructions

Carefully tighten the screws and plastic cover. Avoid over-tightening the screws, as this may cause the plastic to crack or become damaged. Tighten the screw until you see two protruding threads.

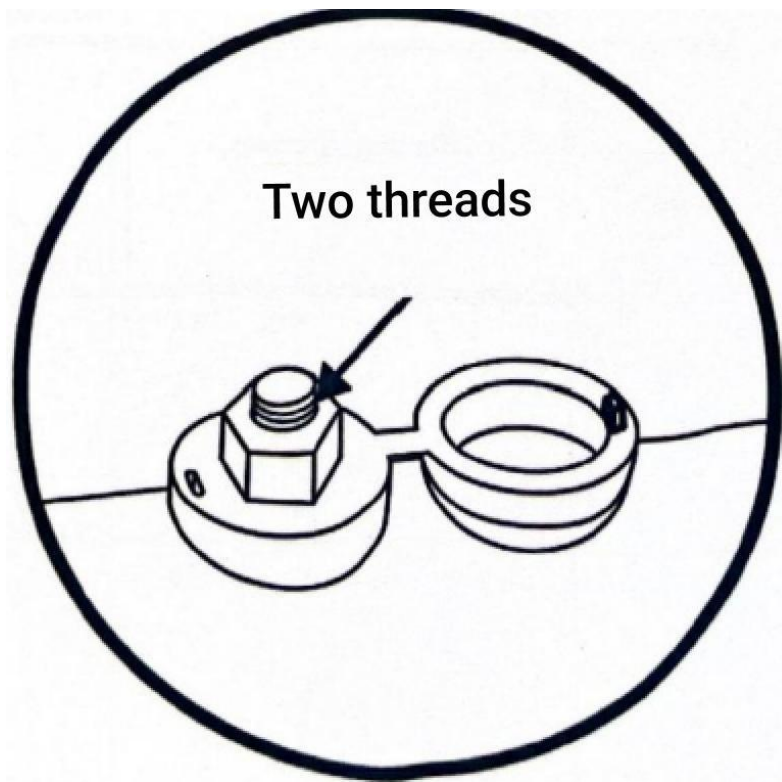

Step 1

Install parts #1, #2 and #3, and make sure to install the component on the correct side as shown in the picture. Part #2 should have the convex side facing up; attach the parts #4 to the holes on either side of the crossbar and secure them using A, F, J, G and I.

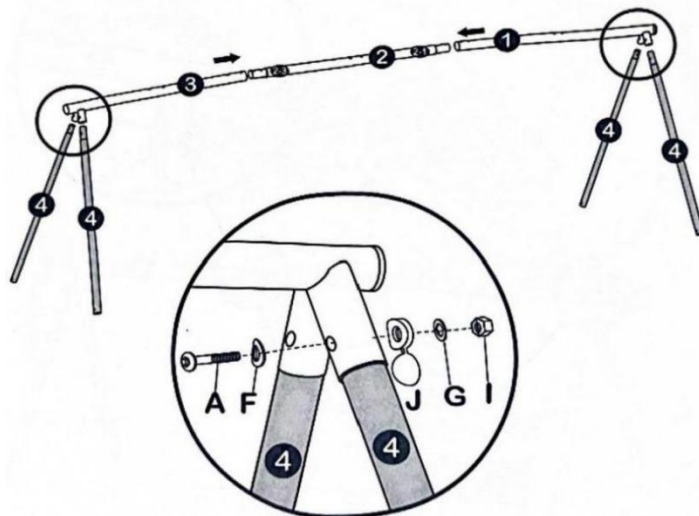

Step 2

Firmly secure the parts #1 and #2 using I, G, J, F and E. But do not secure the parts #2 and #3 at this time. Secure the part #7 to part #3.

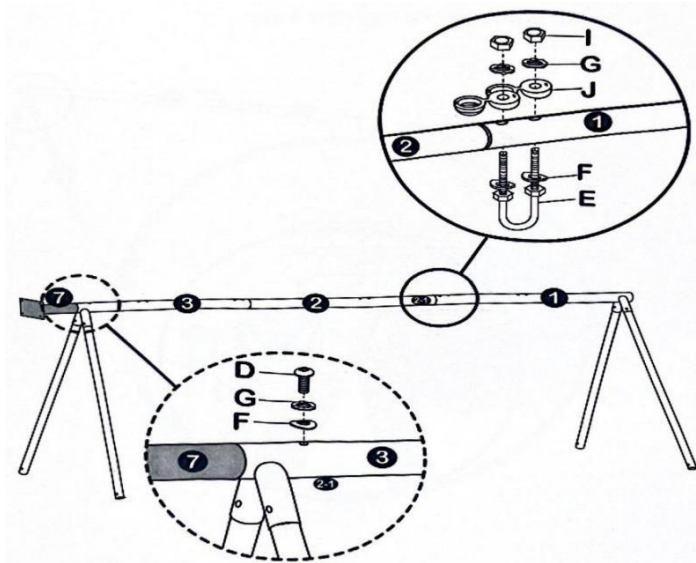

Step 3

Place the tube parts #10 inside the seat #9 edge.

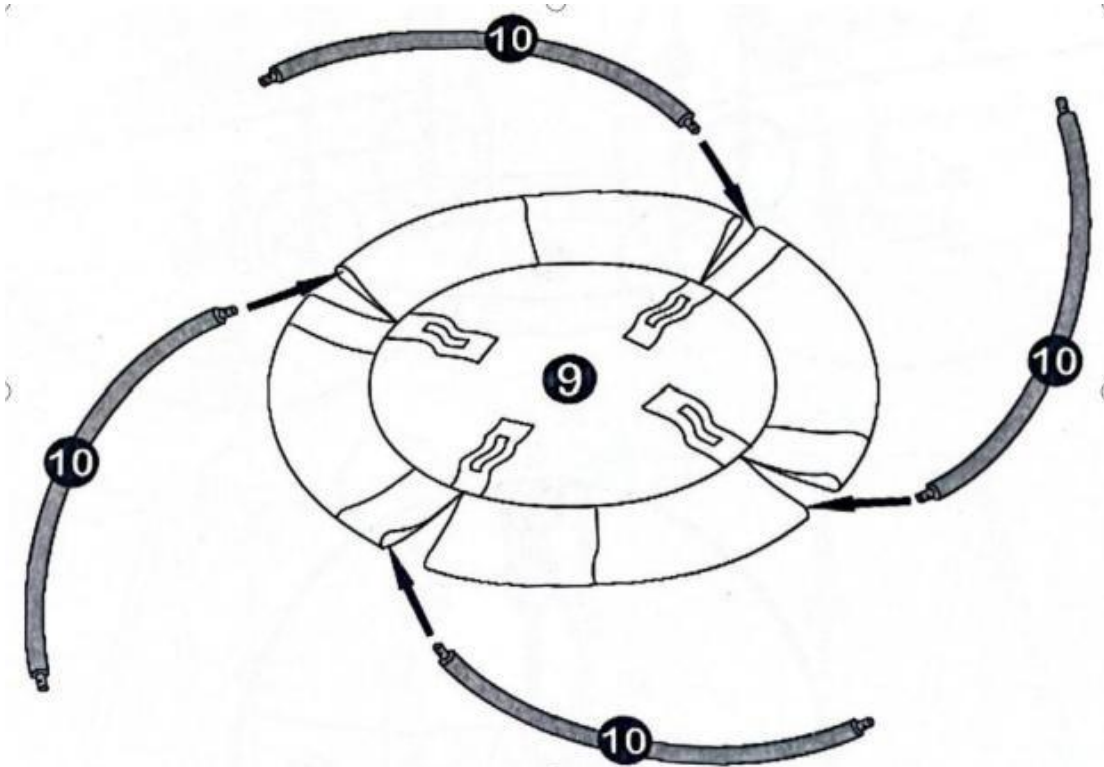

Step 4

Connects the tube parts #10 with fasteners; insert the eyebolts of parts #11 into the holes in the fasteners to connect parts #11 and parts #10.

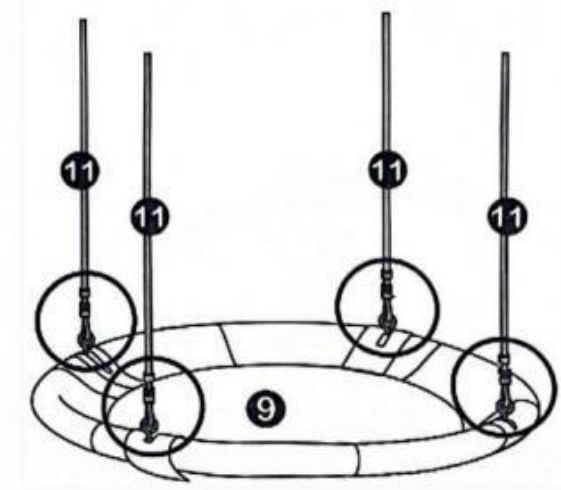

Step 5

Attach the parts #11 and parts #8 to the parts #1, #2 and #3 using I, G, J, F and E. There is no specified requirement for the order of parts #11 and parts #8

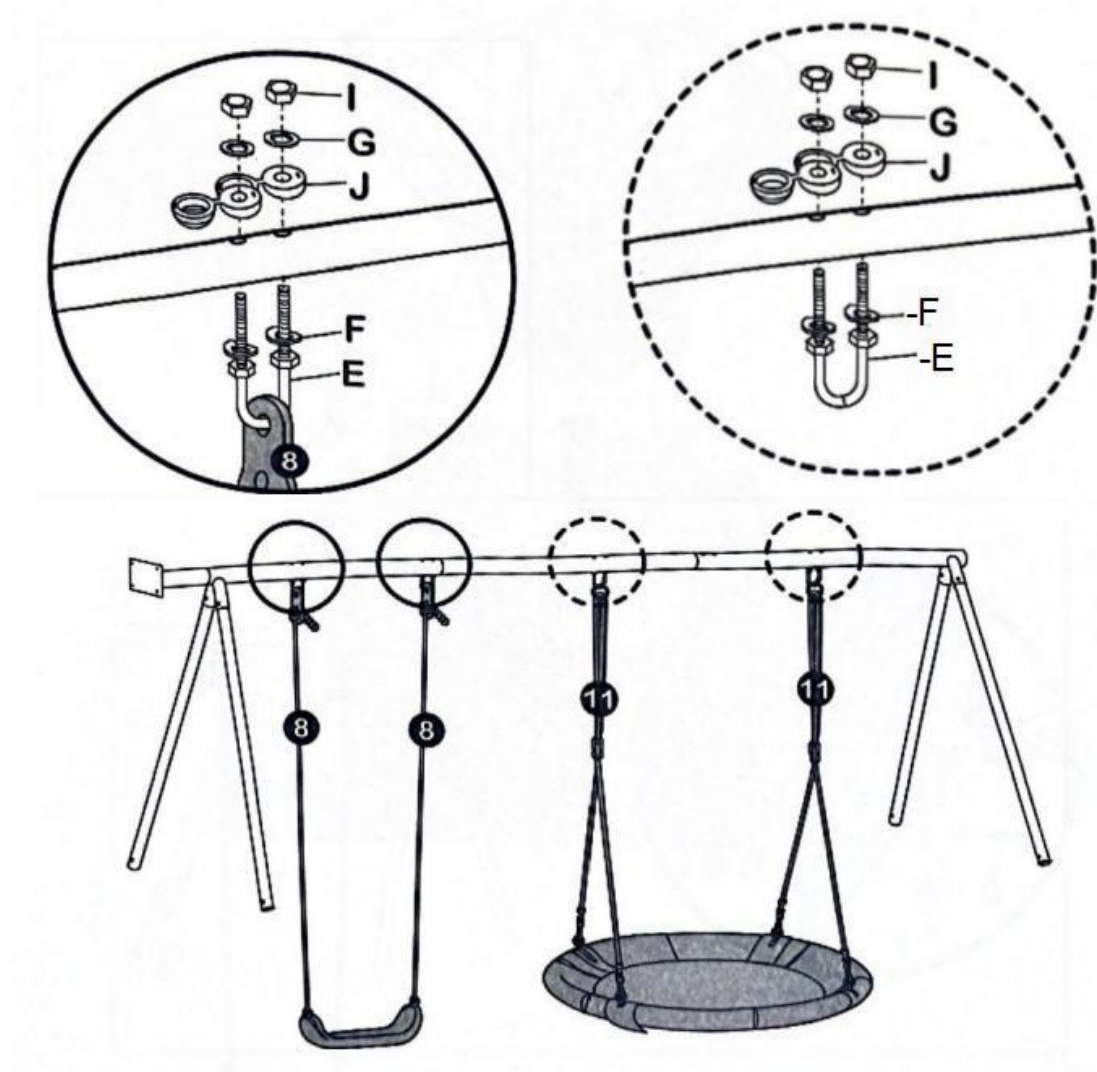

Step 6

Attach the #14 net to the #13 basket first, then connect the part #13 and part #12 using part #7 and C, H, G, I.

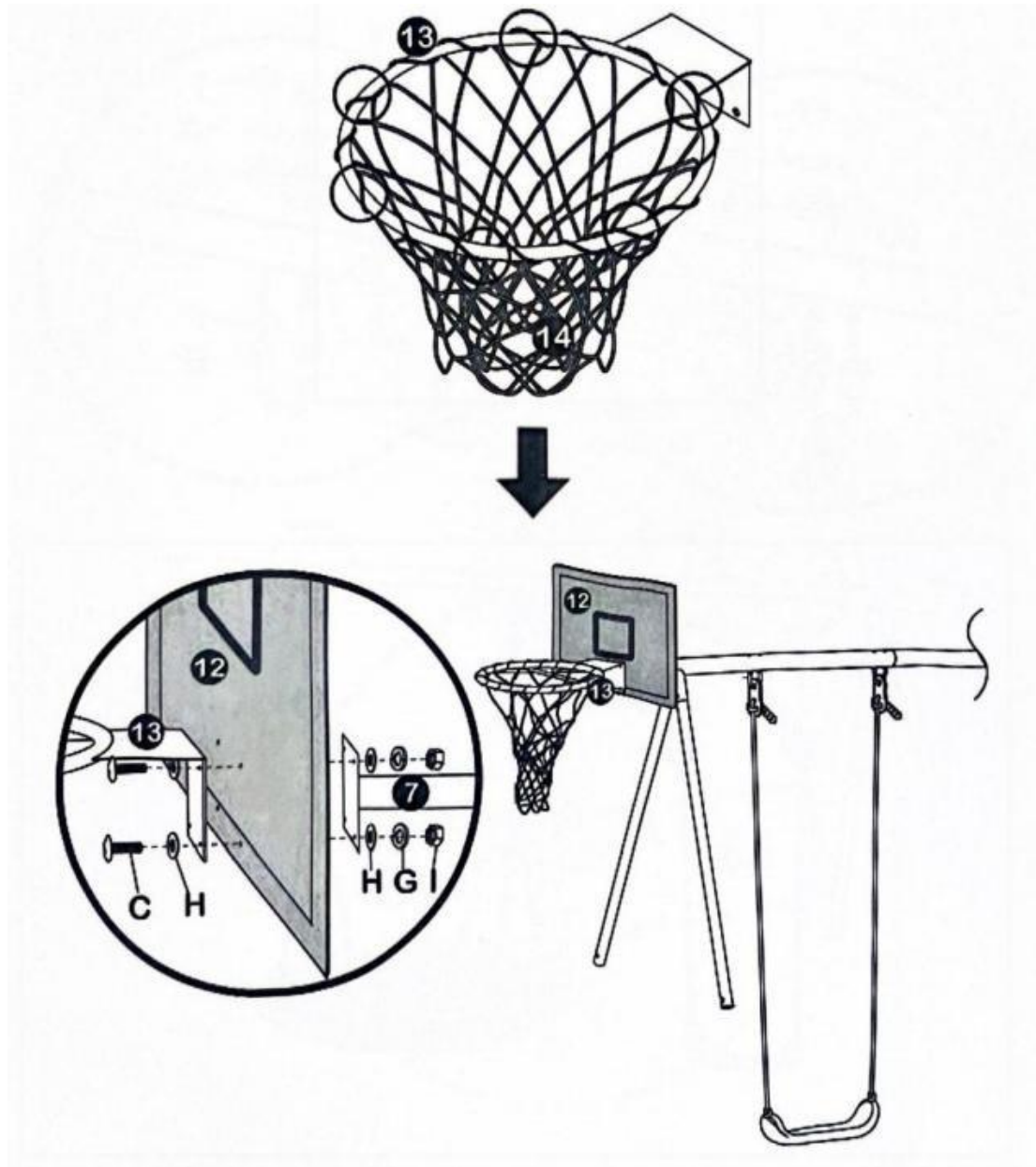

Step 7

Insert 2 #5 tubes into the part #16, and insert part #6 into the corresponding sleeve as shown in the picture.

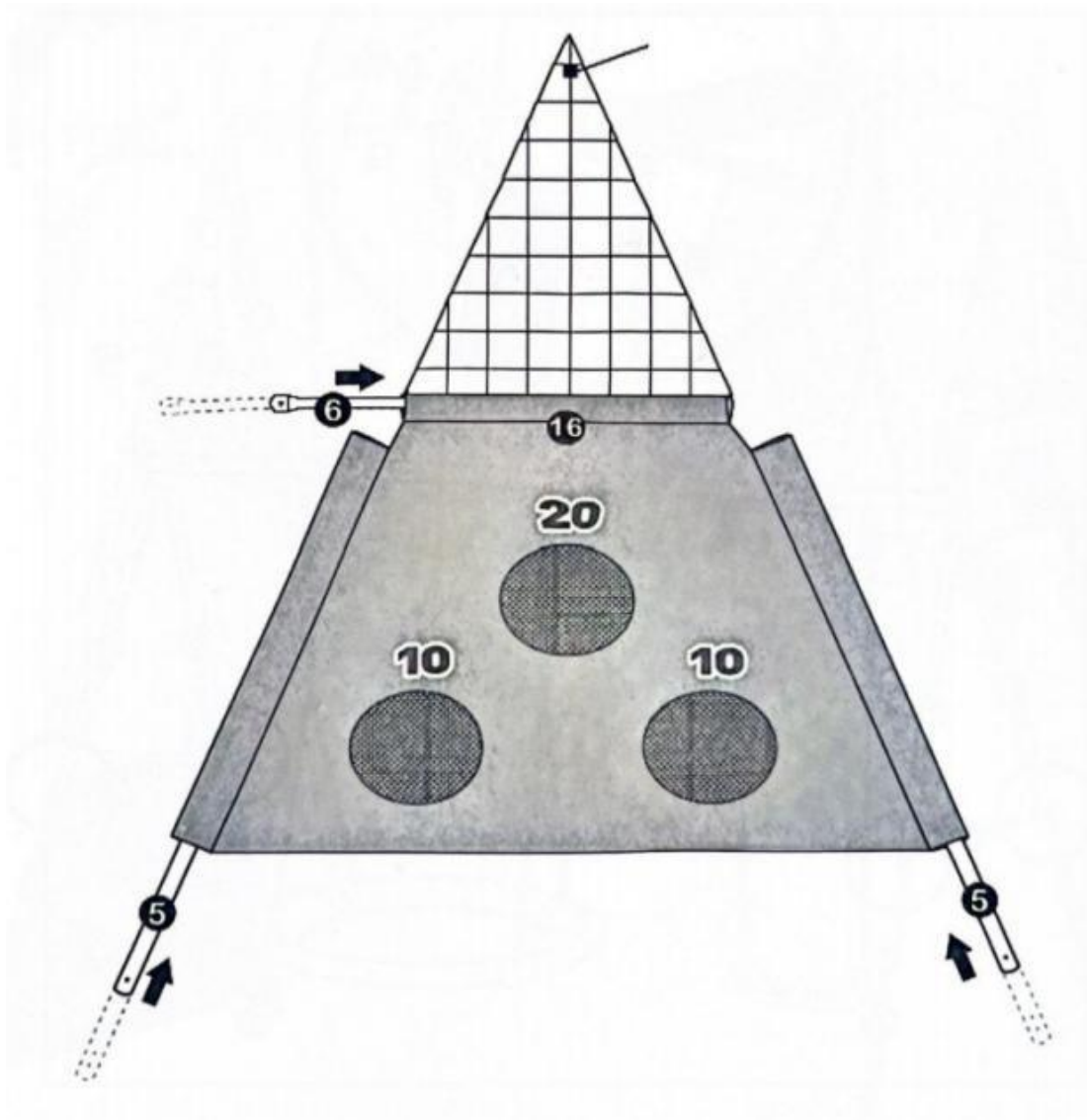

Step 8

Connect and secure parts #4, parts #5, and part #6 using B, H, J, G, and I.

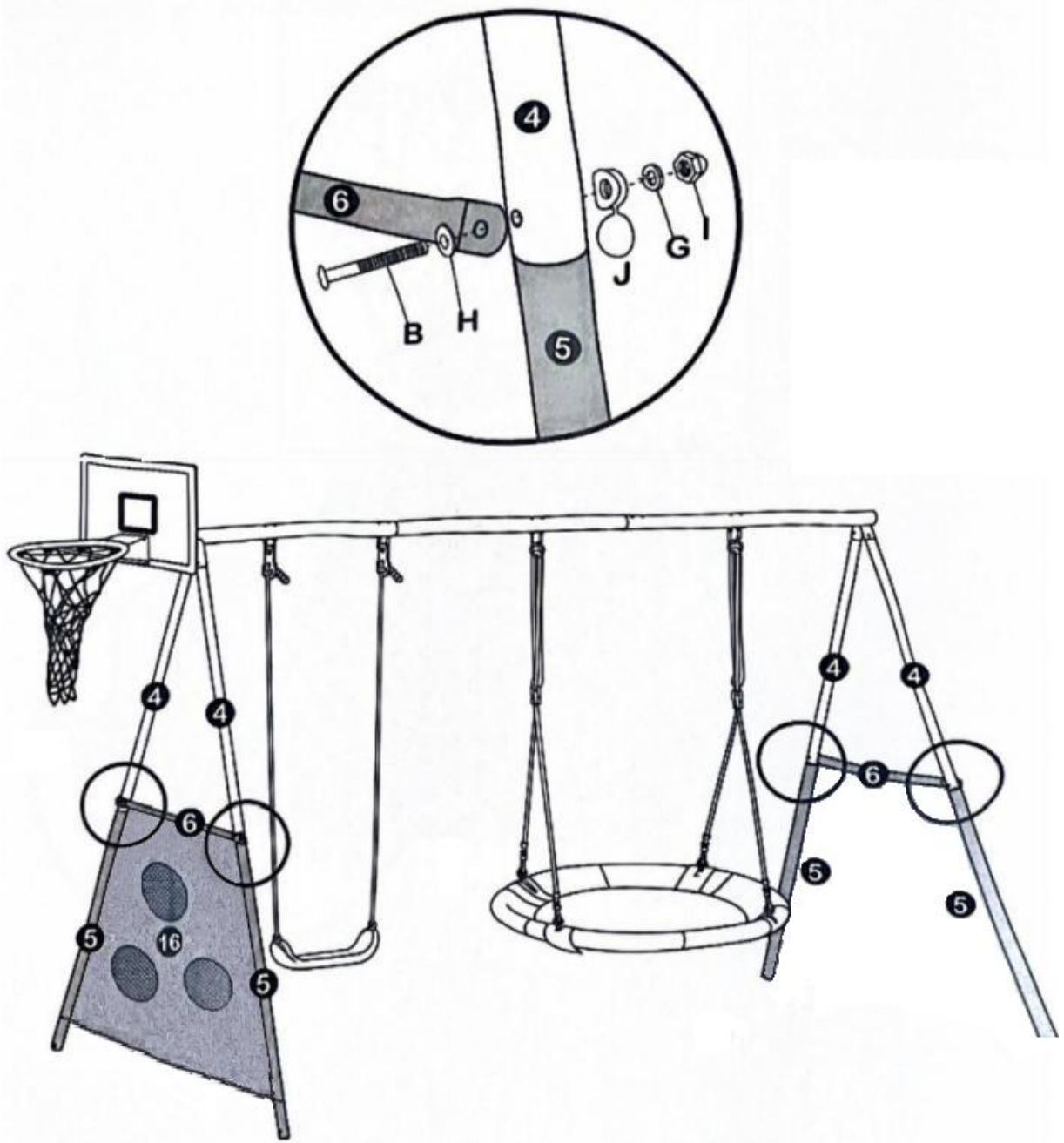

Step 9

On one side of the frame, tie and secure the part #16 using the part #15. Note that the red mark should be at the top of the frame.

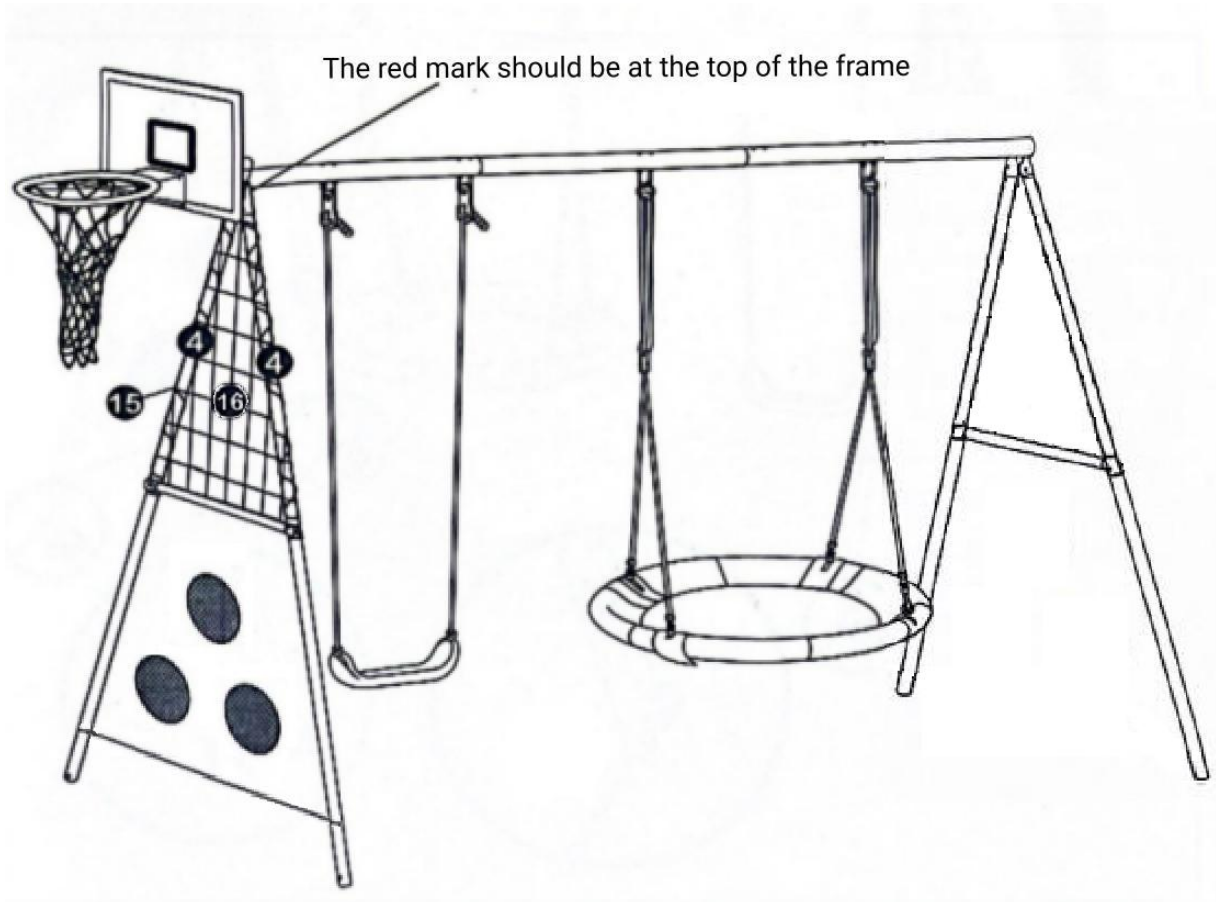

Step 10

Fix the swing set to the ground using parts #18 and N as shown in the pictures below.

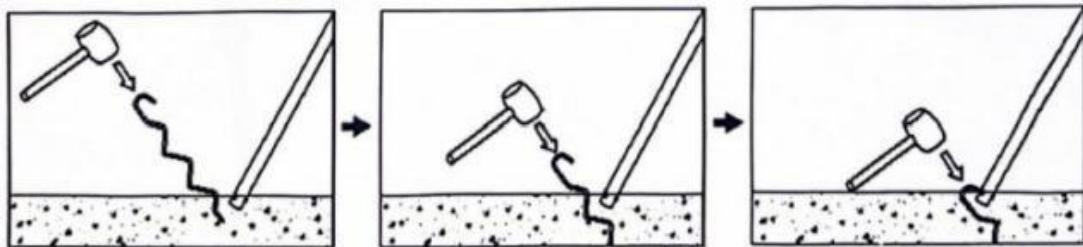
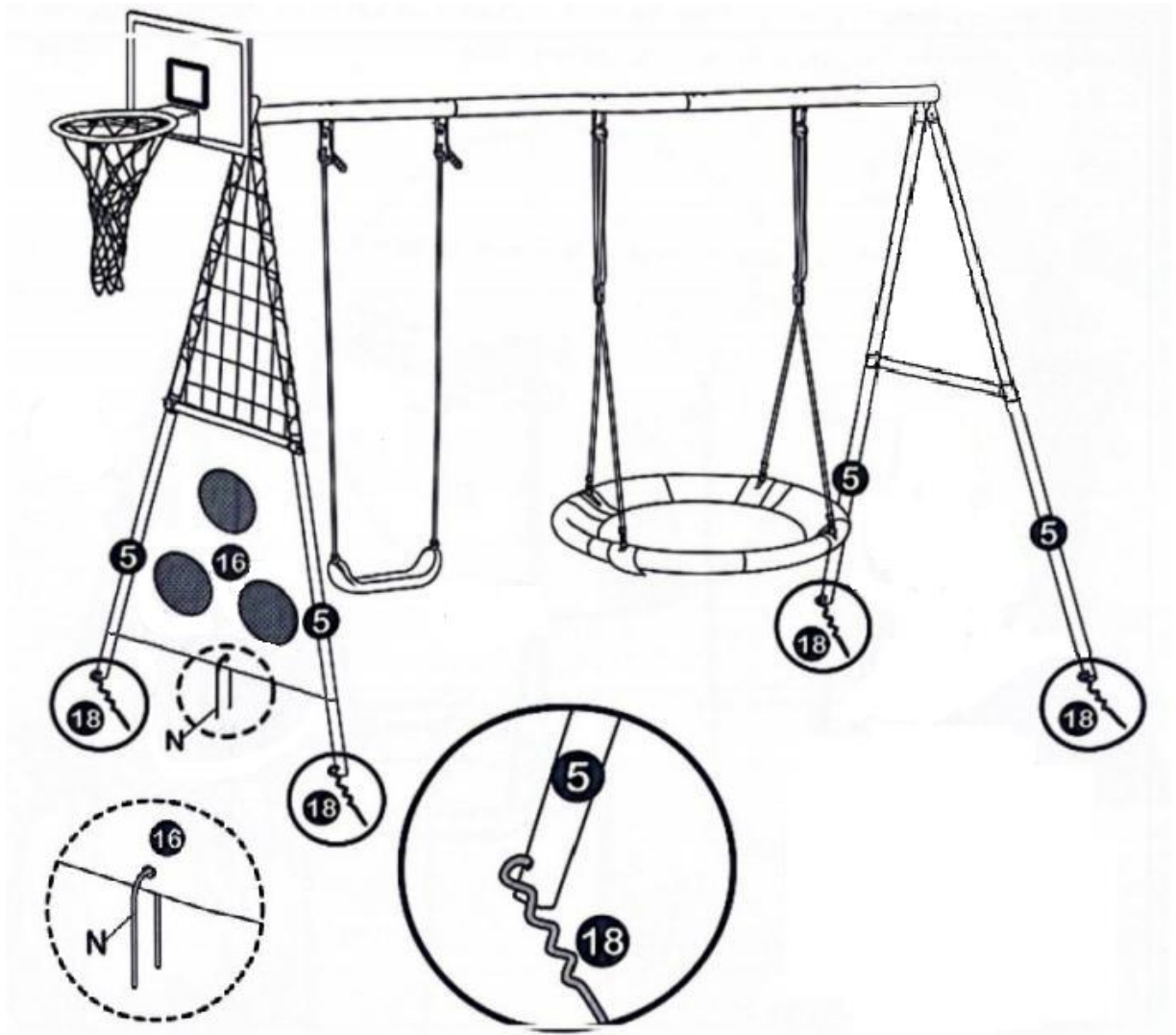

Slide Assembling (Tips: The specific coding for each part is shown in the figure.)

Step 1

Connect the parts #8 and #9 using part #12, and secure using #X, #W, and #K, and tighten with #M (#X x 2, #W x 2, #K x 2); install the 2 parts #13 using #X, #W and #K, and tighten with #M (#X x 4, #W x 4, #K x 8); install the part #11 using #S, #W and #K, and tighten with #M (#S x 2, #W x 2, #K x 4).

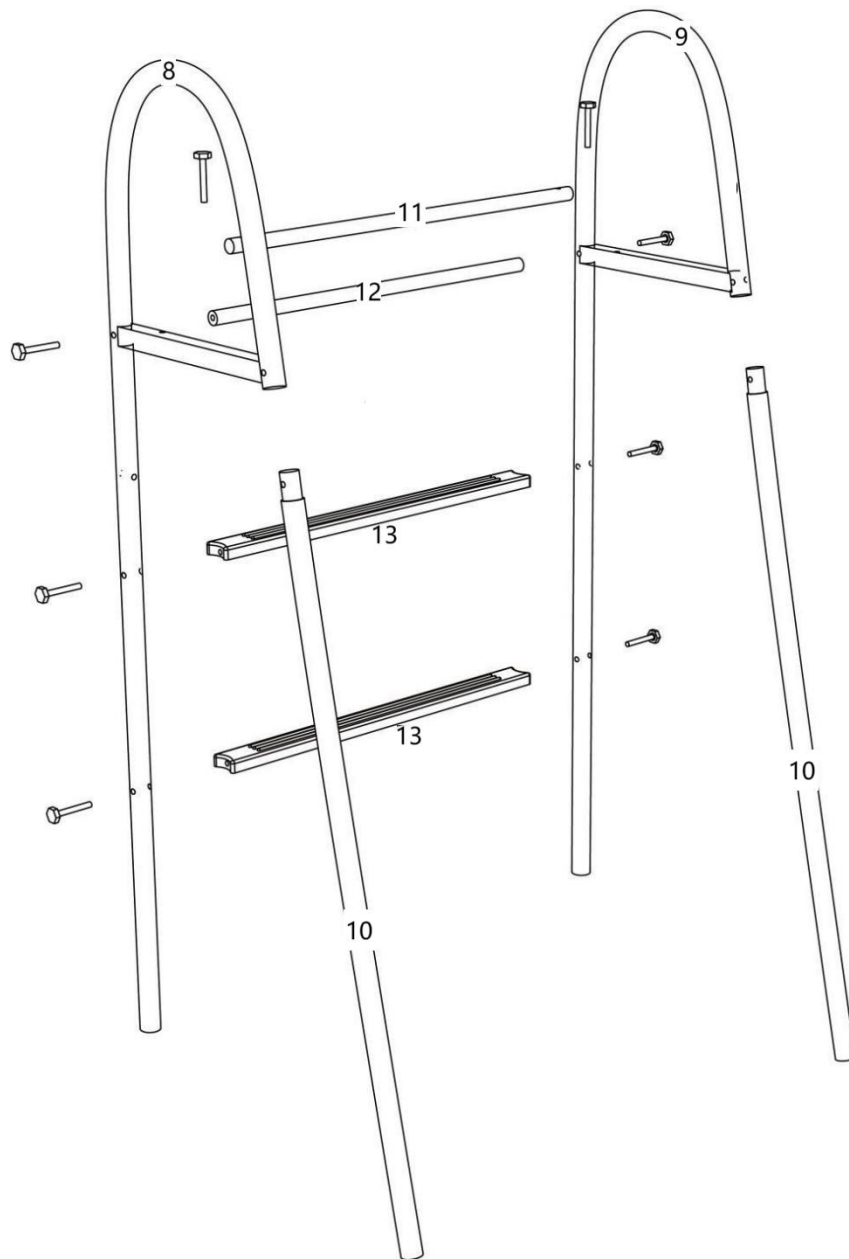

Step 2

Snap the part #14 onto the slide, secure using #L2, #W and #K, and tighten with #M (#L2 x 4, #W x 4, #K x 8)

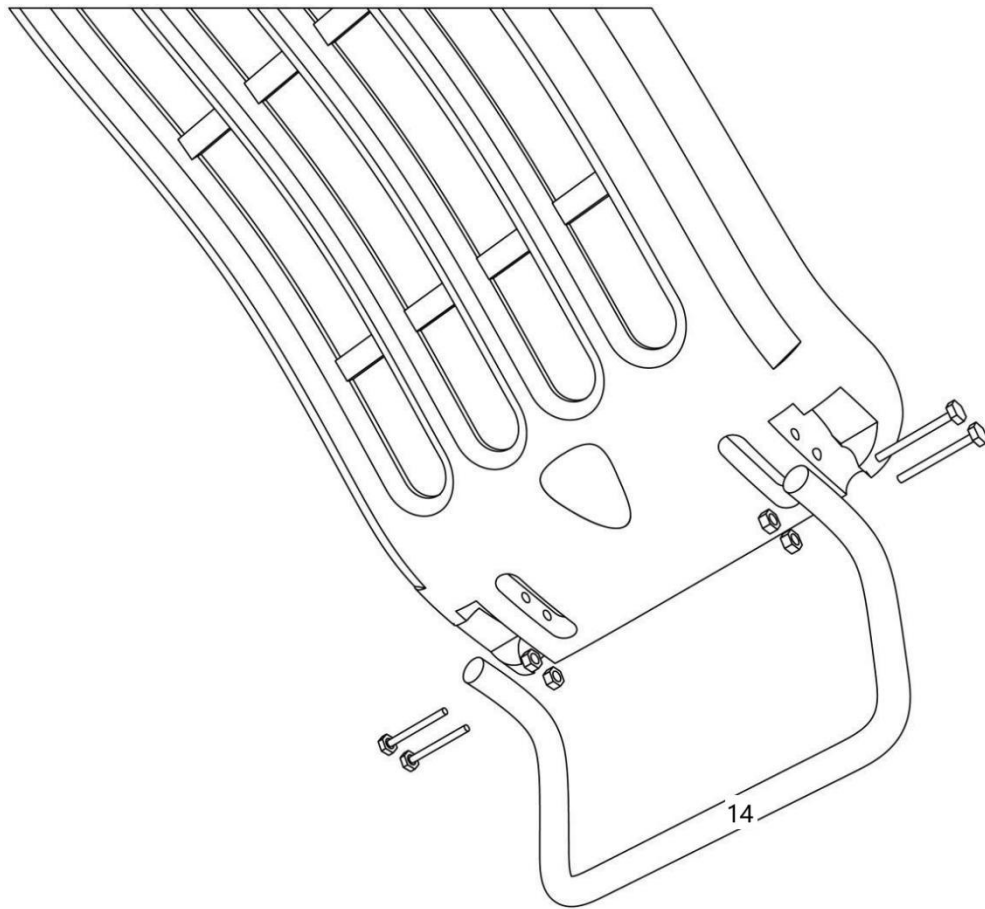

Step 3

Insert the 2 parts #10 into the stair, assemble the slide with the stair using #N2, #W and #K, and tighten with #M. (#N x 2, #W x 2, #K x 2)

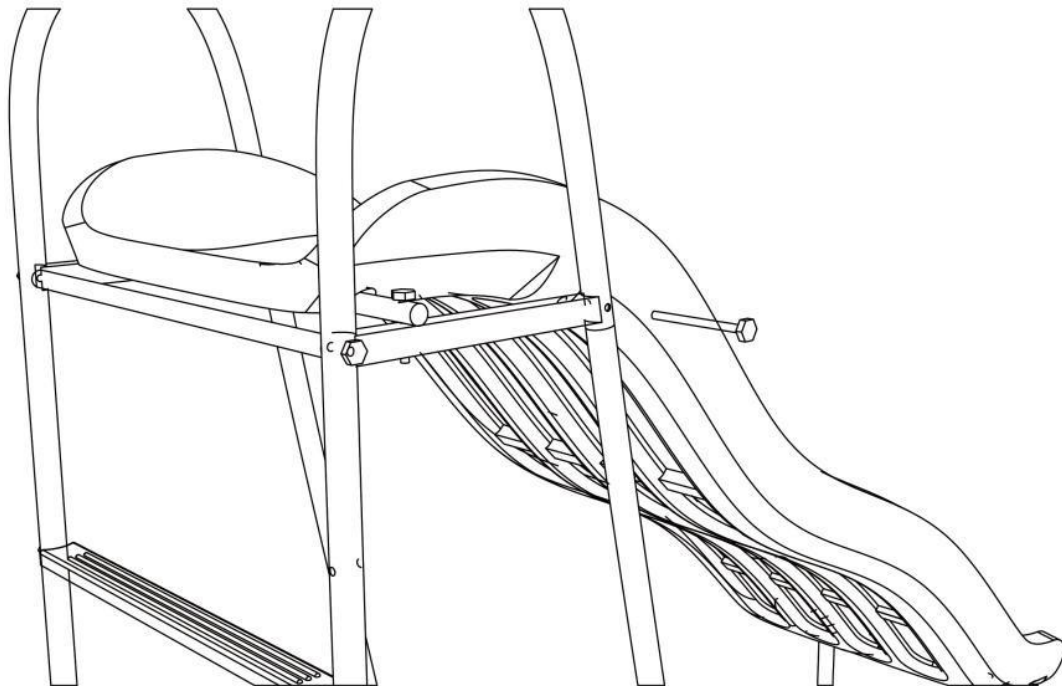
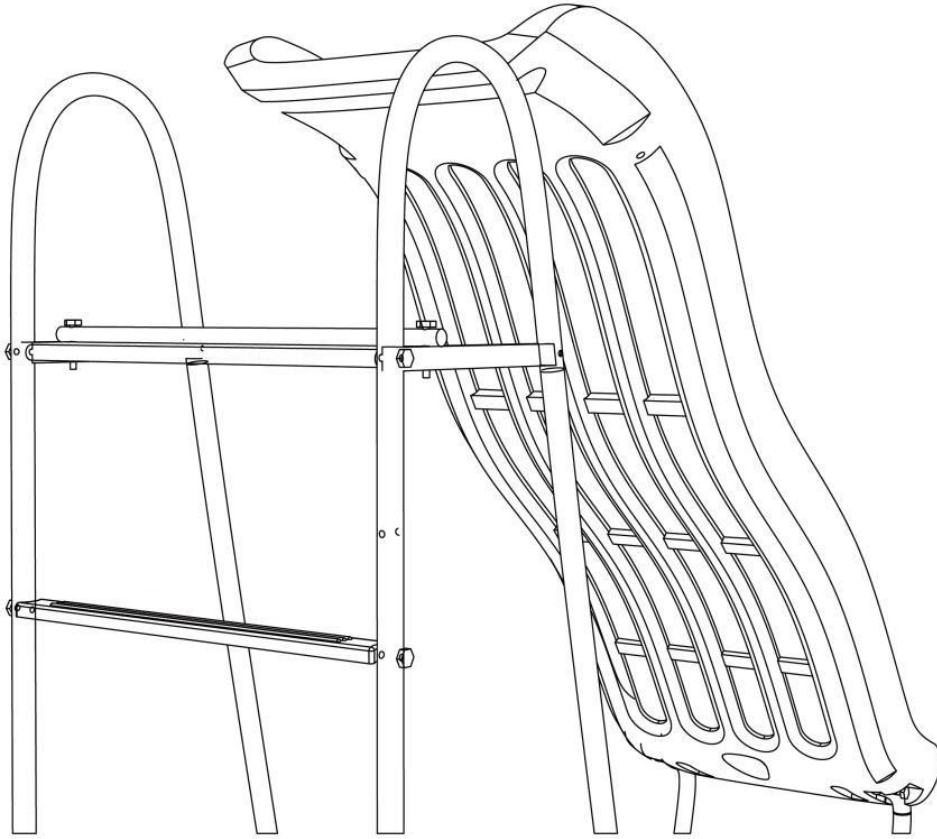

Step 4

Connect the slide and the swing using part #15, secure using #Y and #K, and tighten with #M.
Fix with Z. (#Y x 2, #K x 2,#Z x 2)

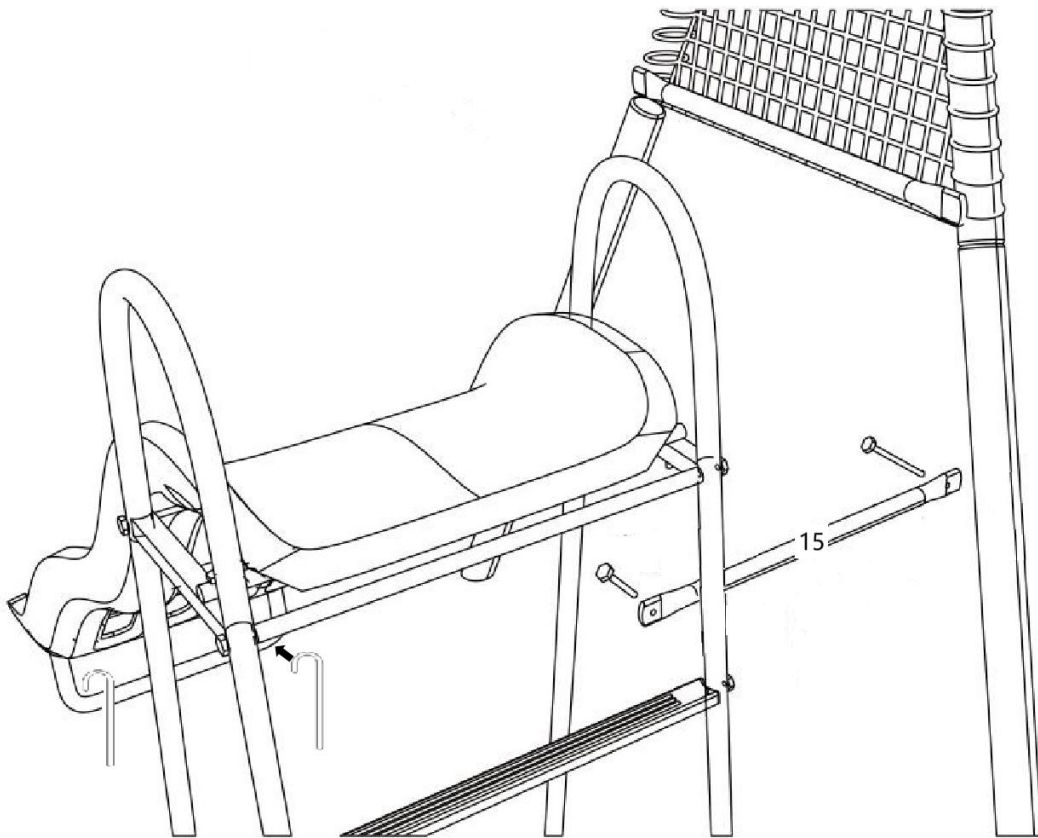

Congratulations! The assembly of your swing set has been completed!

Prior to permitting children to use the swing set, verify its stability and thoroughly inspect all screws and fasteners. Remember, children should ONLY use the swing set under adult supervision. Each swing may ONLY be used by one child at a time.

Please read the warnings in this manual and refrain from allowing children to play with the swing if it shows signs of damage or is missing parts. When assembling, only use parts from the kit or spare parts provided by the manufacturer.