

Assembly Manual

Office Chair

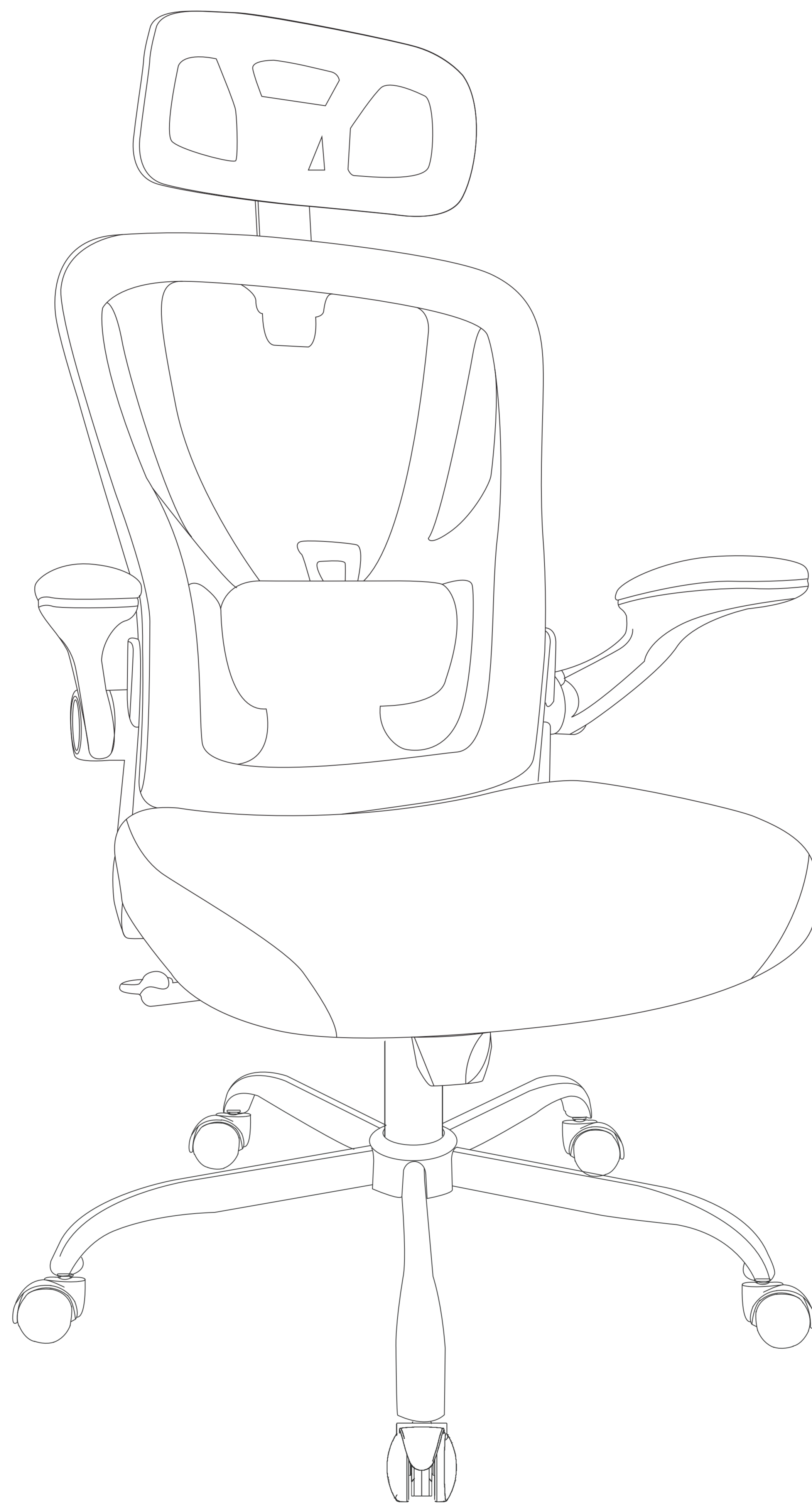

Please read this manual carefully before any operation and keep it properly for future use.

Exploded View

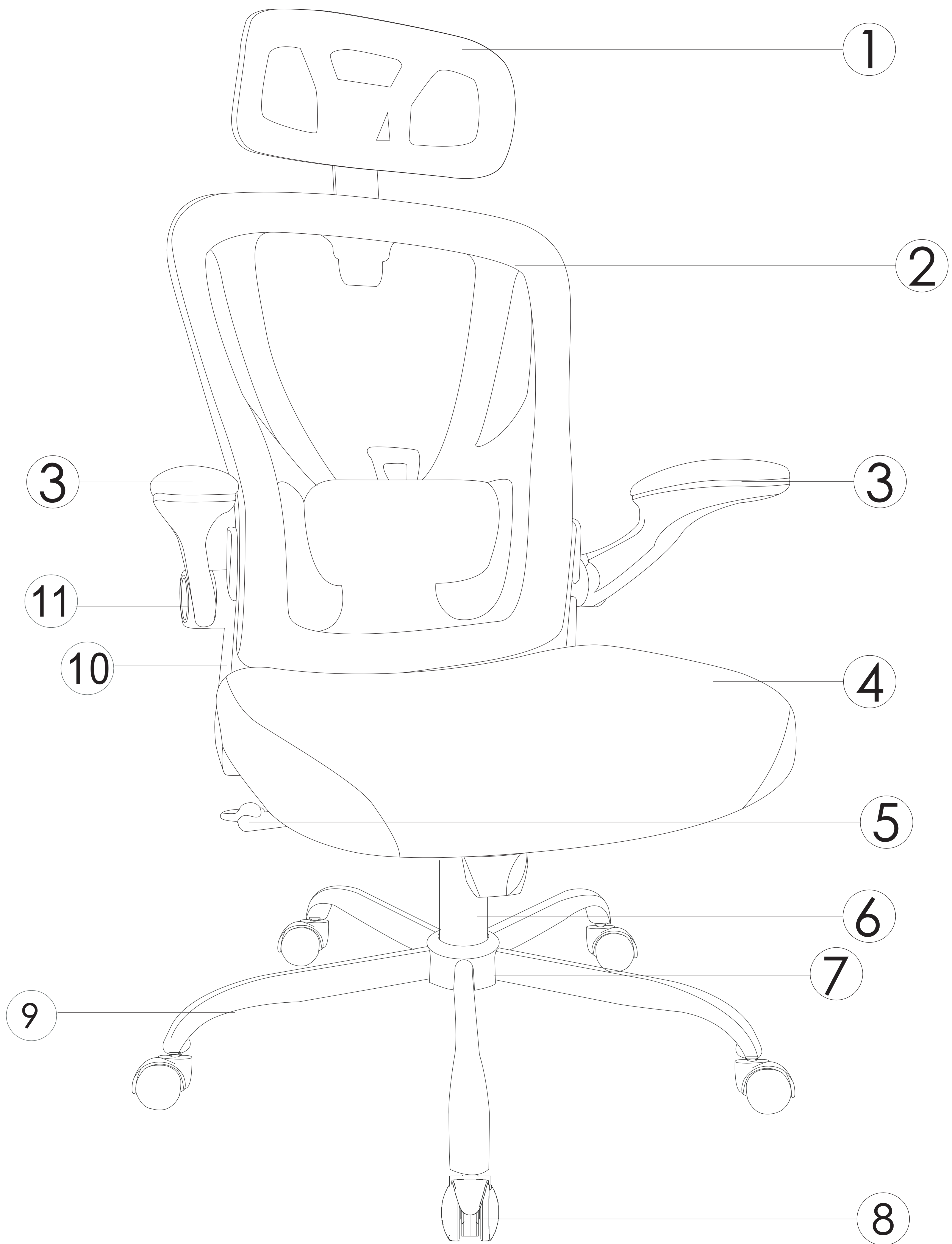

Components List

10 min

Assemble Time

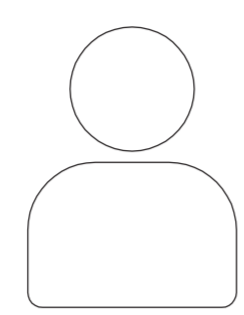

One People

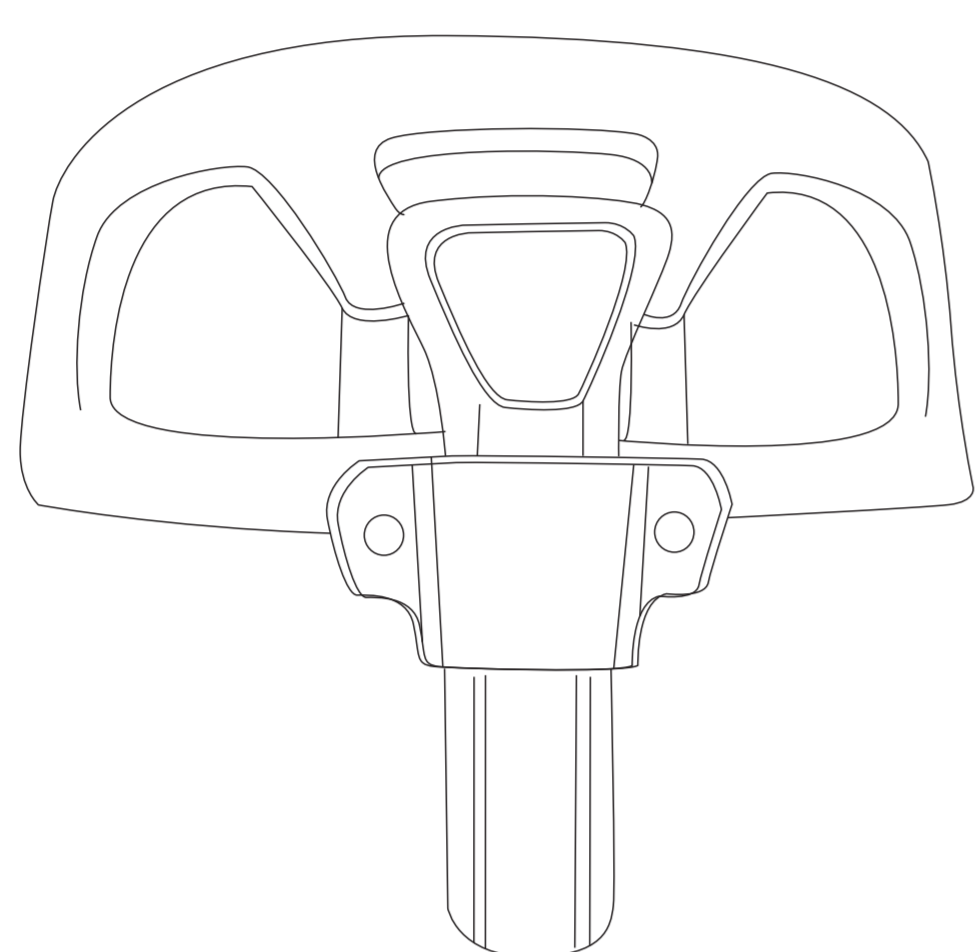

1

Headrest (X1)

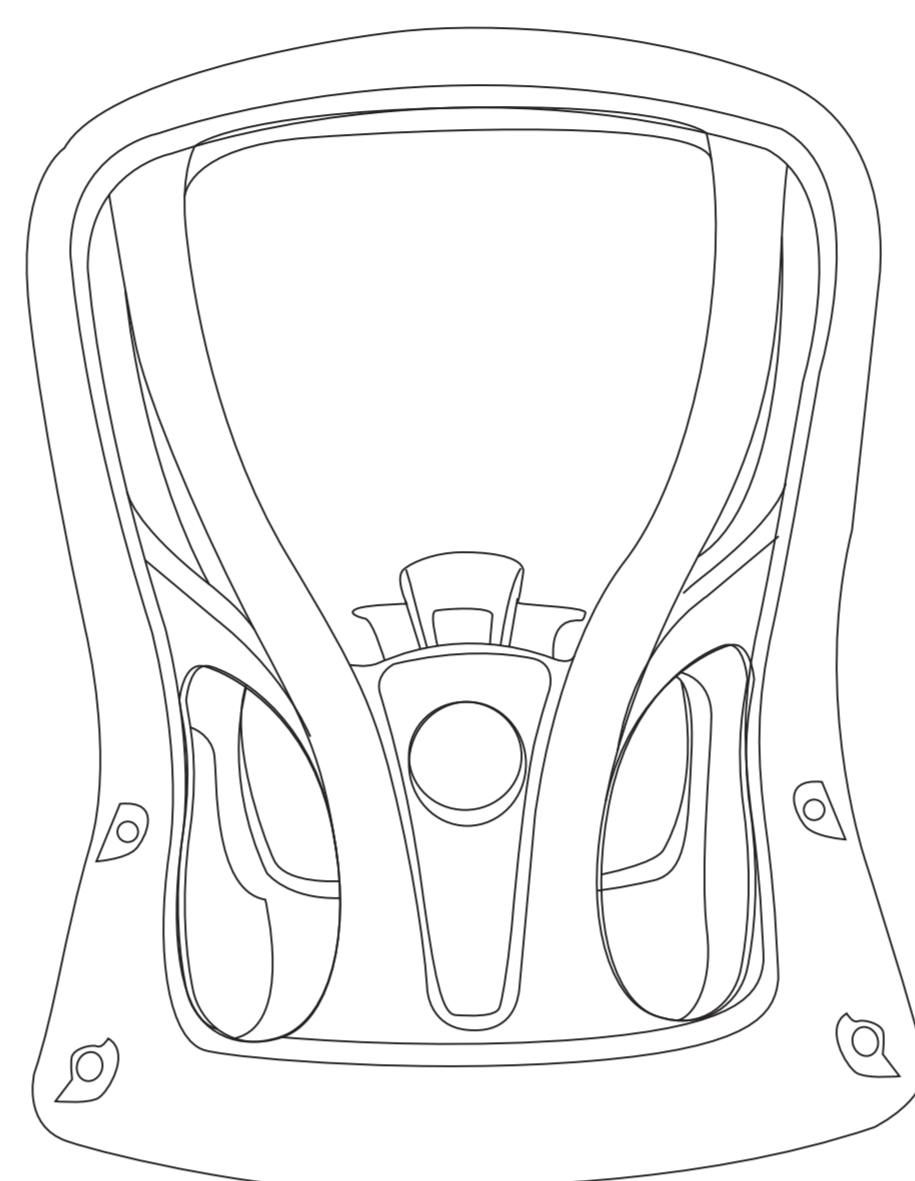

2

Backrest (X1)

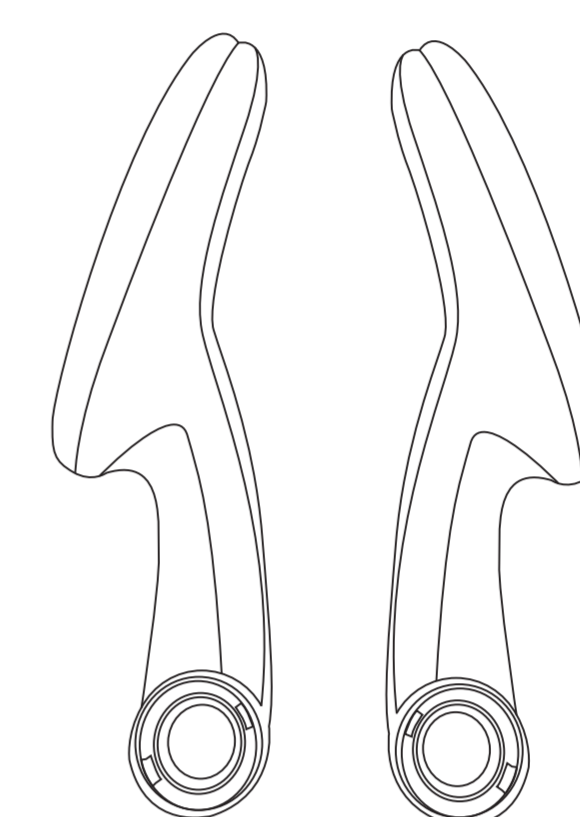

3

Armrest (X2)

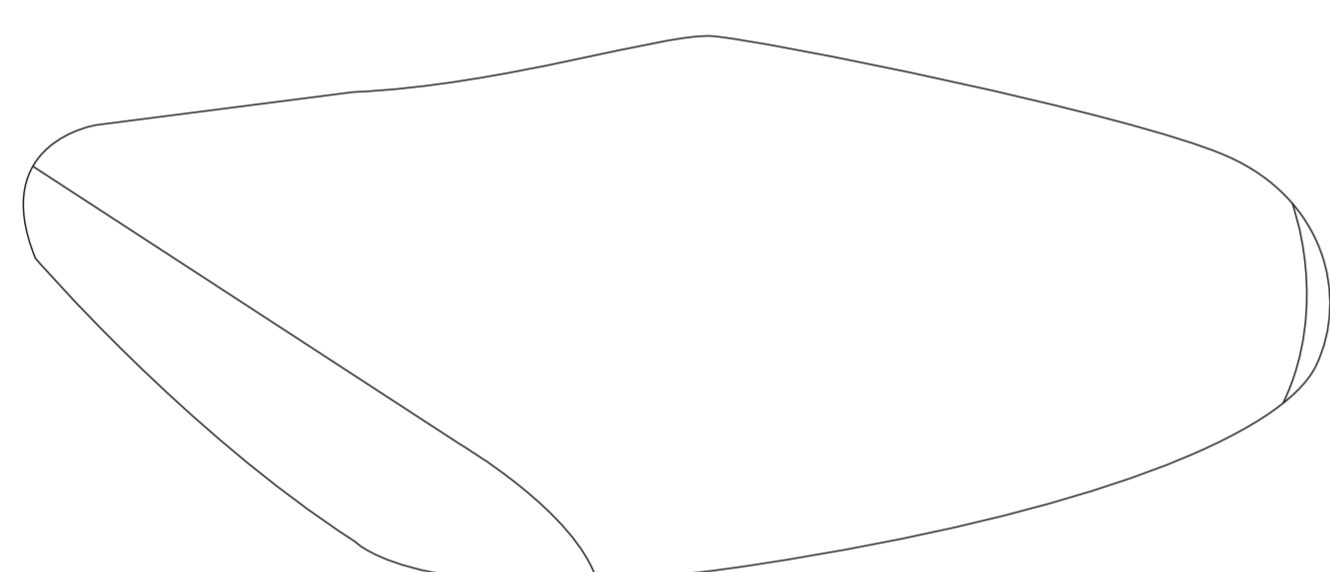

4

Seat pan (X1)

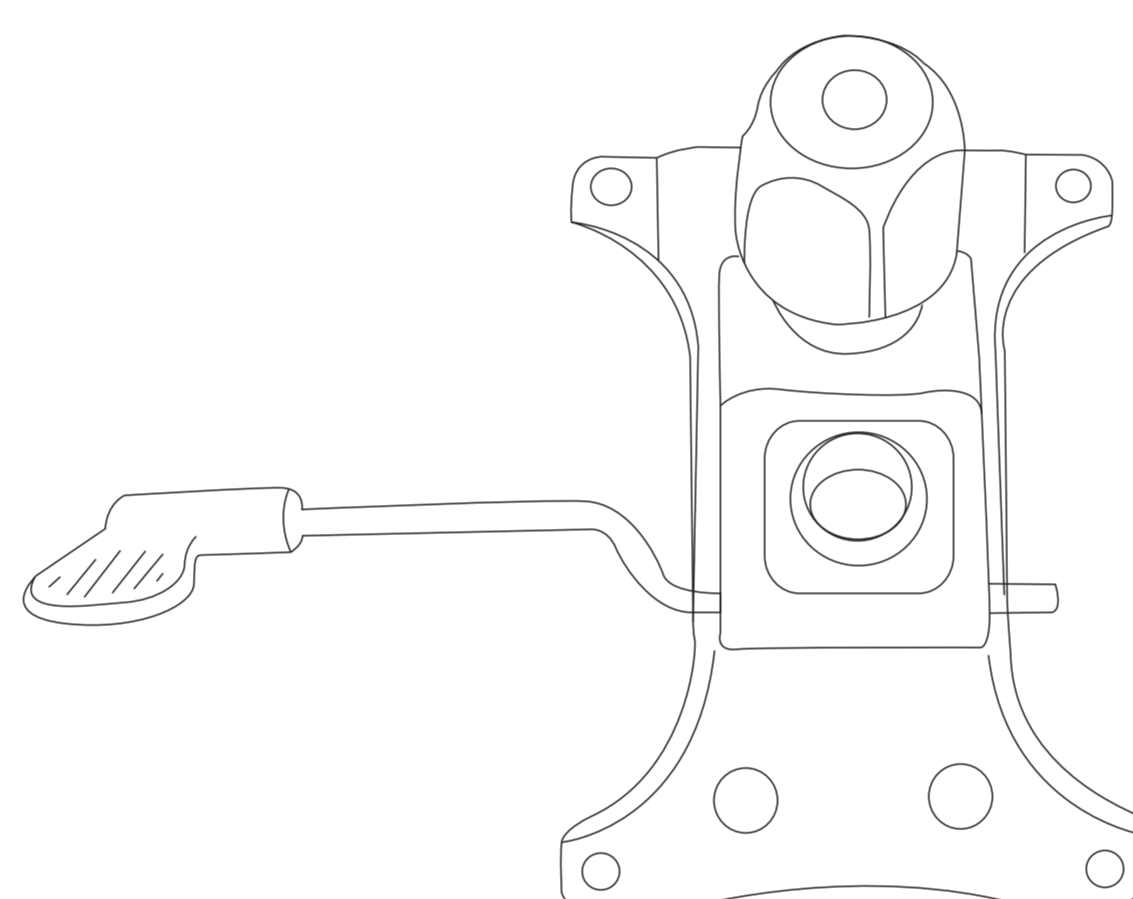

5

Mechanism (X1)

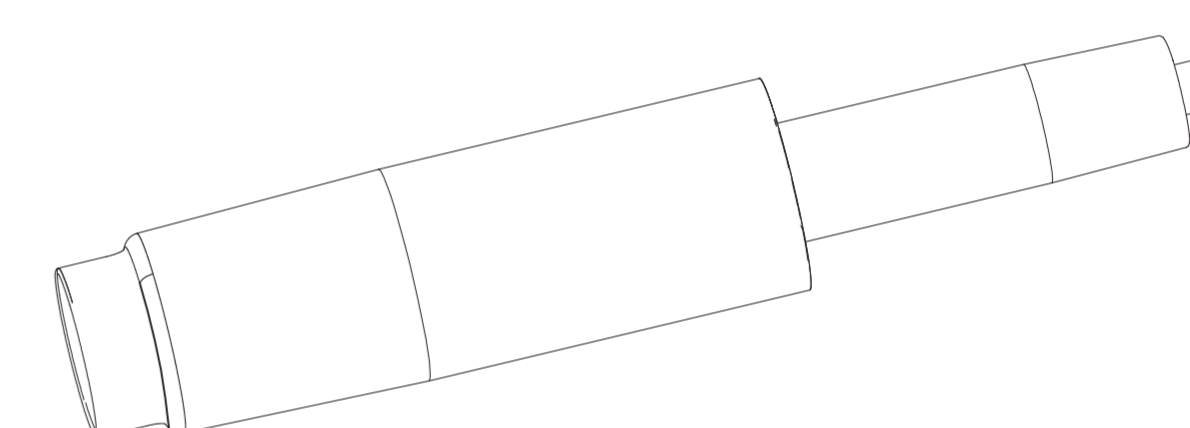

6

Gas lift (X1)

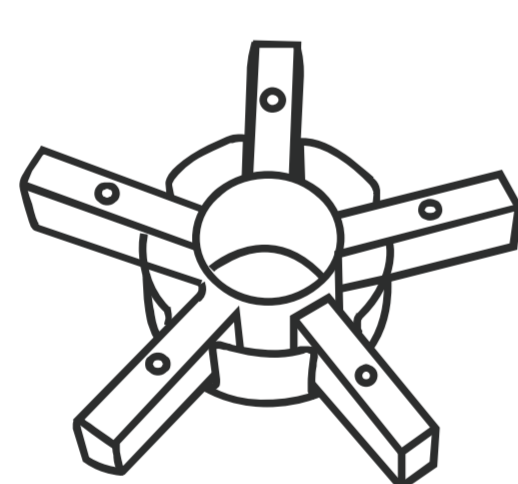

7

5-Star base's tube (X1)

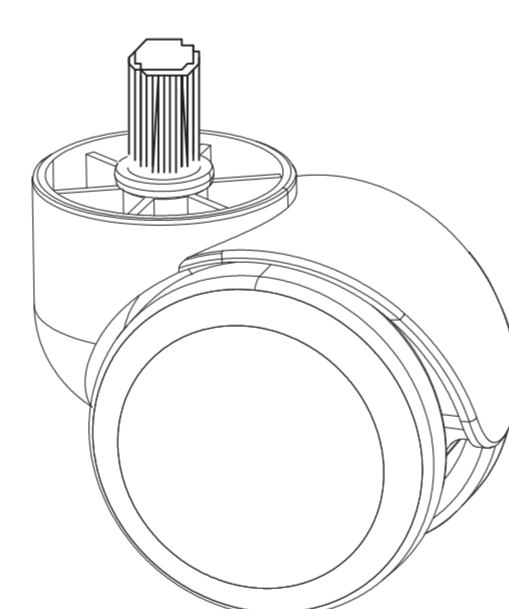

8

Casters (X5)

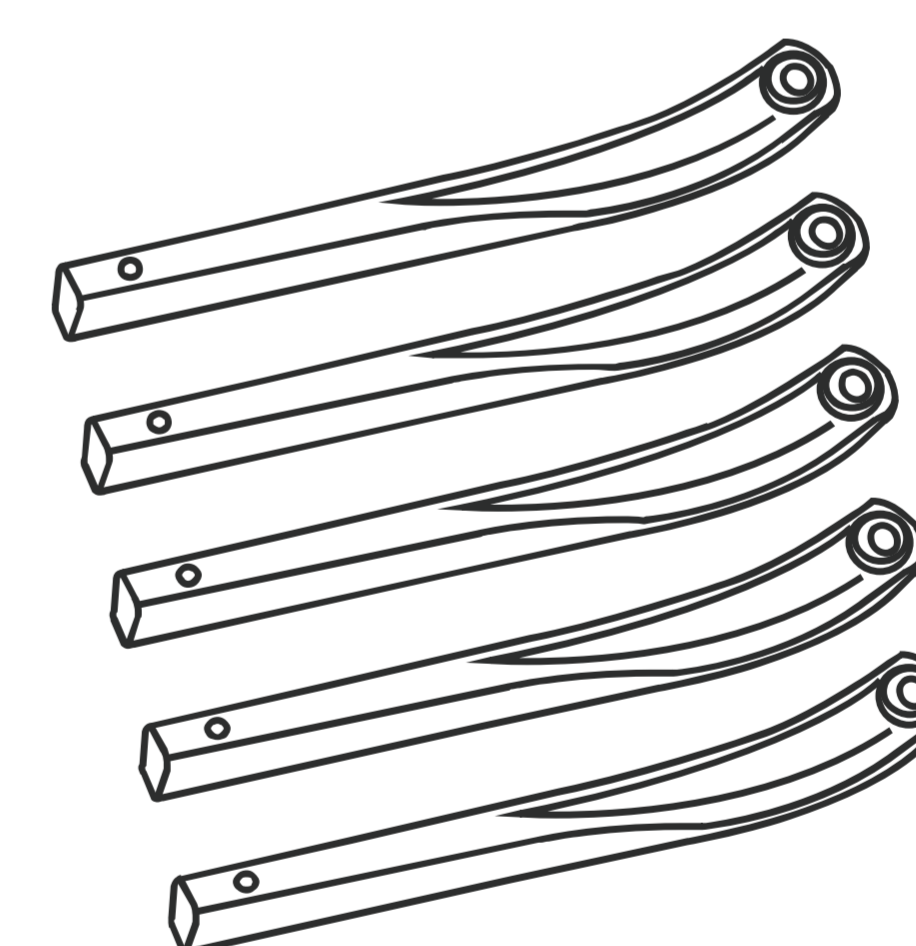

9

Leg (X5)

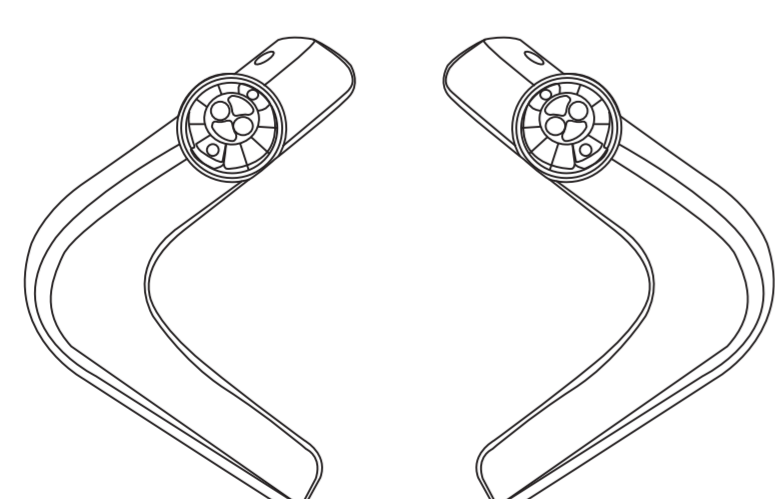

10

Armrest base (X2)

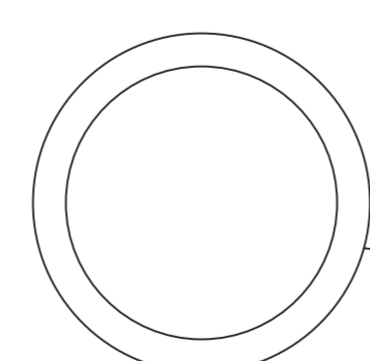

11

Cover (X2)

Components list

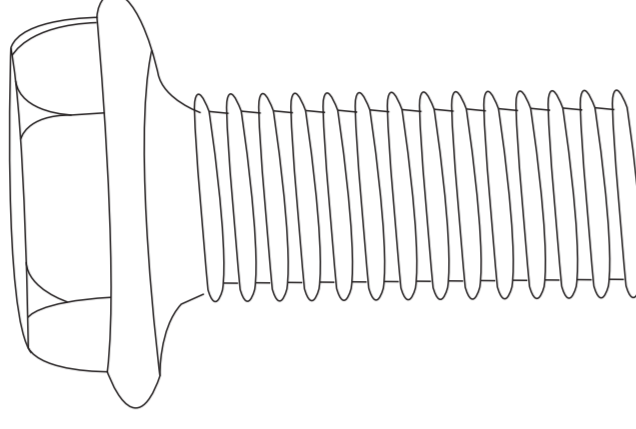
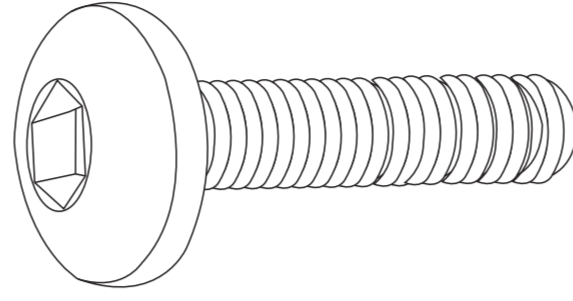
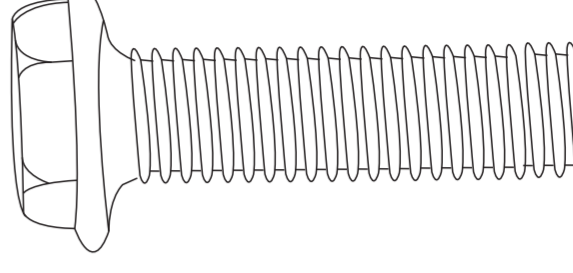
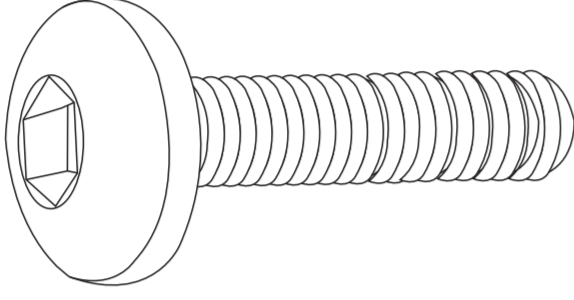
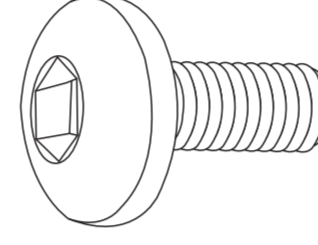
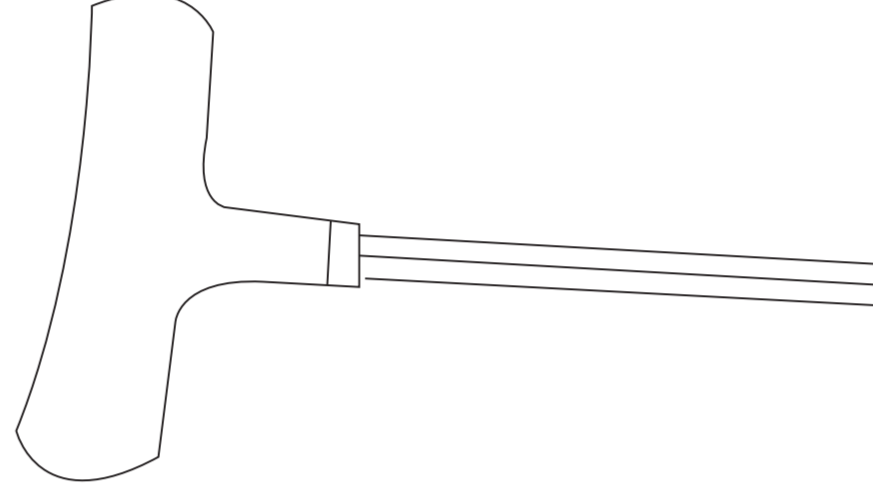
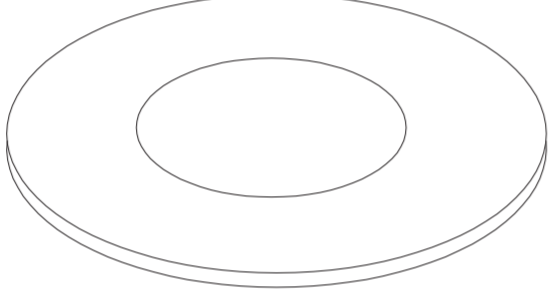
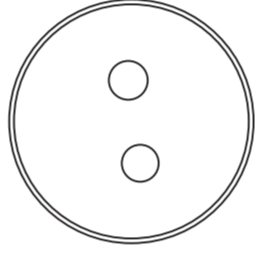
A			B			C		
								
Bolt	M6x20	4+1	Bolt	M6x25	6+1	Bolt	M6x35	4+1
D			E			F		
								
Bolt	M6x20	4+1	Washers	M6x14	5+1	Allen wrench		1
G			H					
								
Washers	M6x16	8+1	Iron sheet		2			

Assembly Instruction

STEP 1

Insert the leg(9) into 5-star base's tube(7). Use the bolts(E) to fix. Do NOT fully tighten the bolts until all of them are in the correct holes. This will allow you slight adjustments during the assembly.

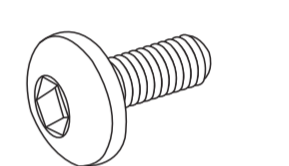
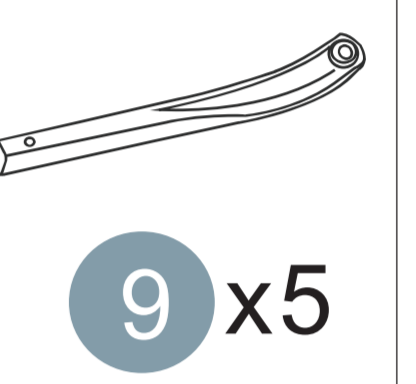
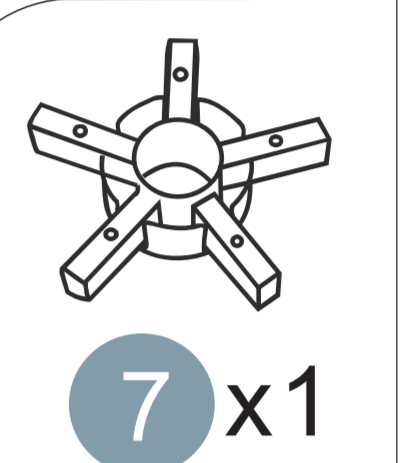
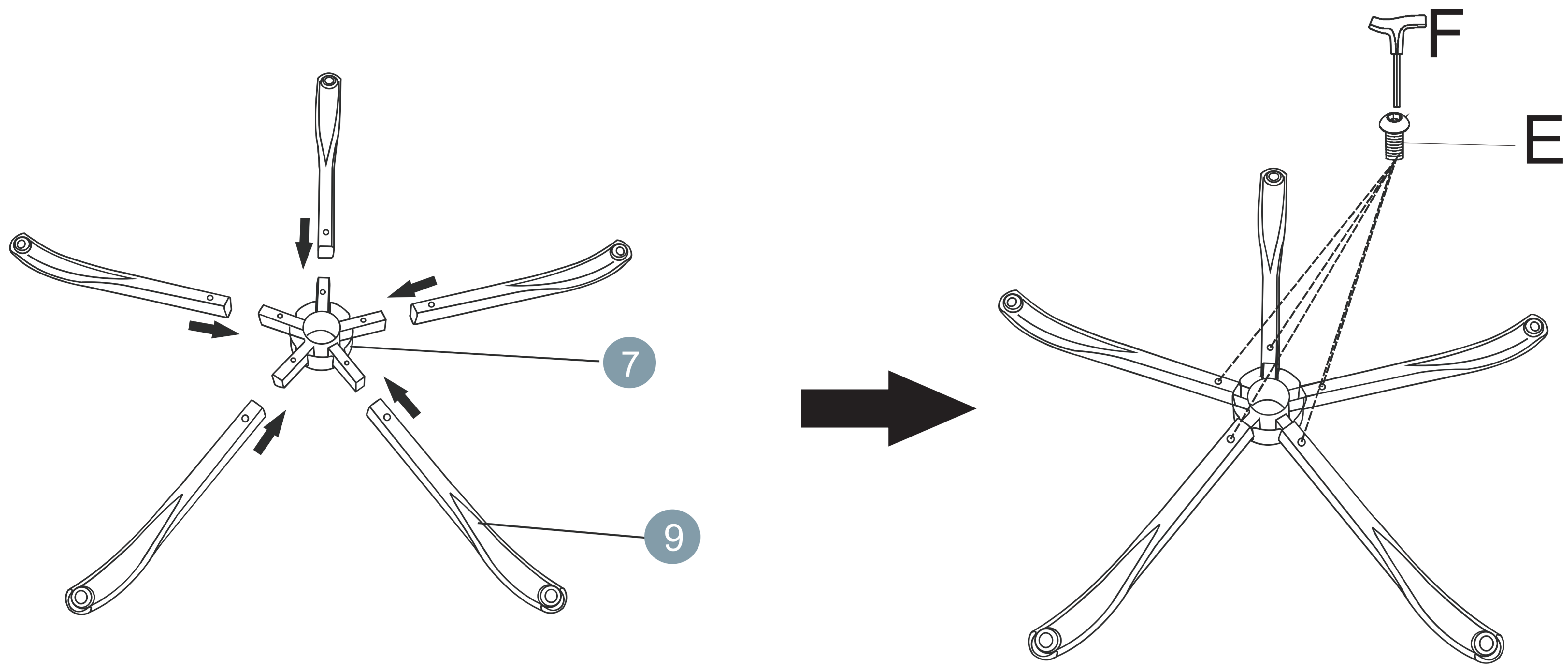

E x 5

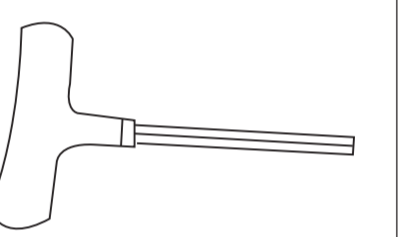

F x 1

STEP 2

Insert the casters(8) into leg(9) and connect gas lift(6) with 5-star base's tube(7)

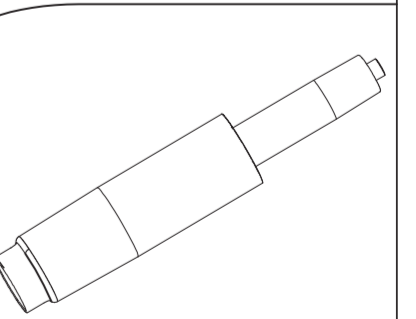
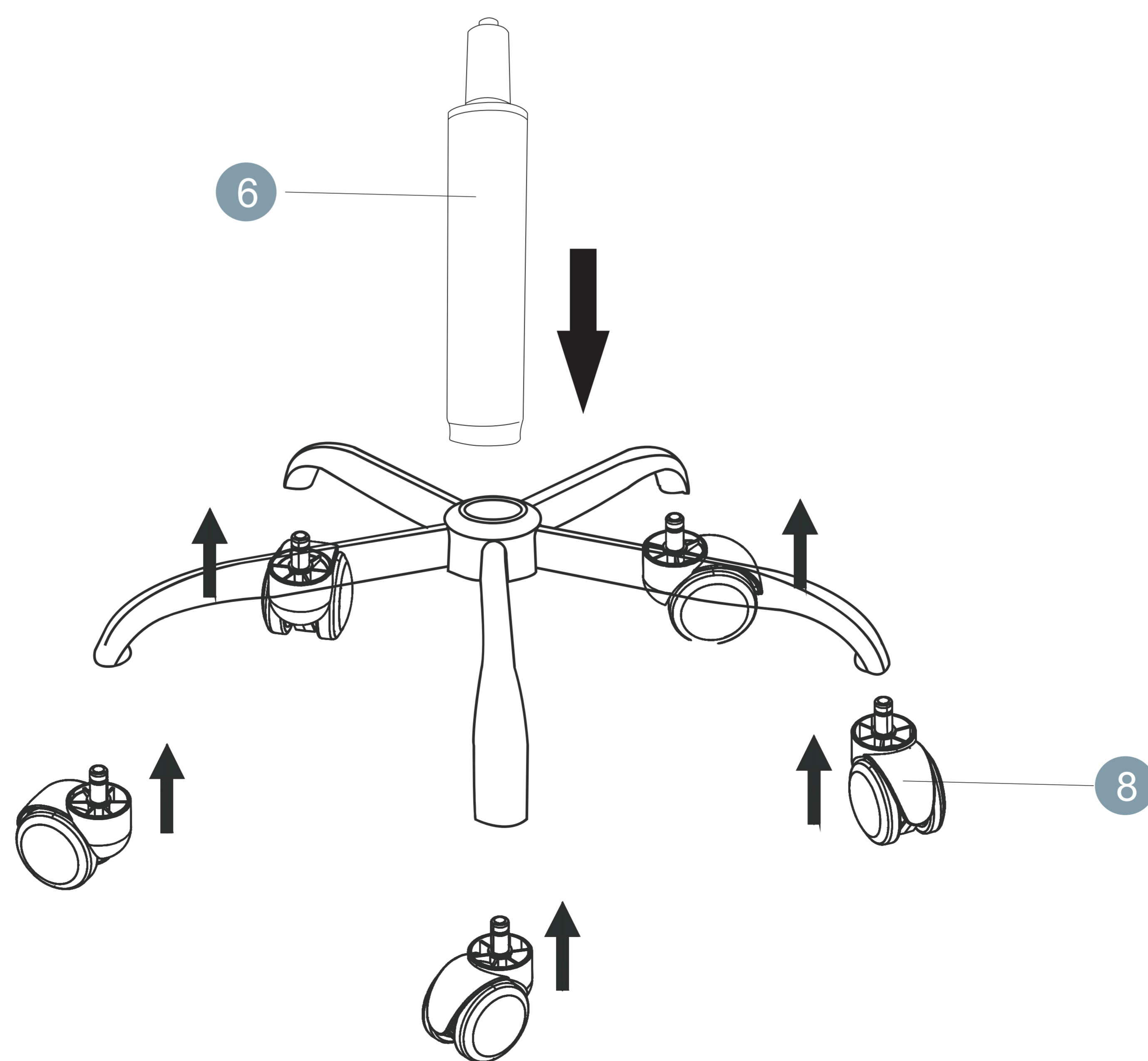

6 x 1

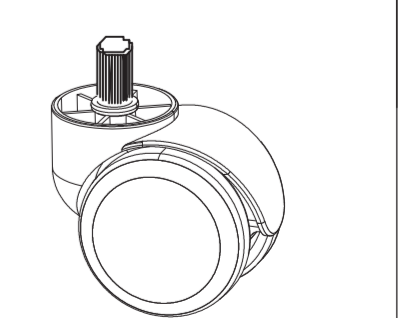

8 x 5

Assembly Instruction

STEP 3

Connect the armrest(3) with armrest base(10). Use the iron sheet(H) and bolts(D) to fix. Finally, snap the decorative cover(11) into the armrest.

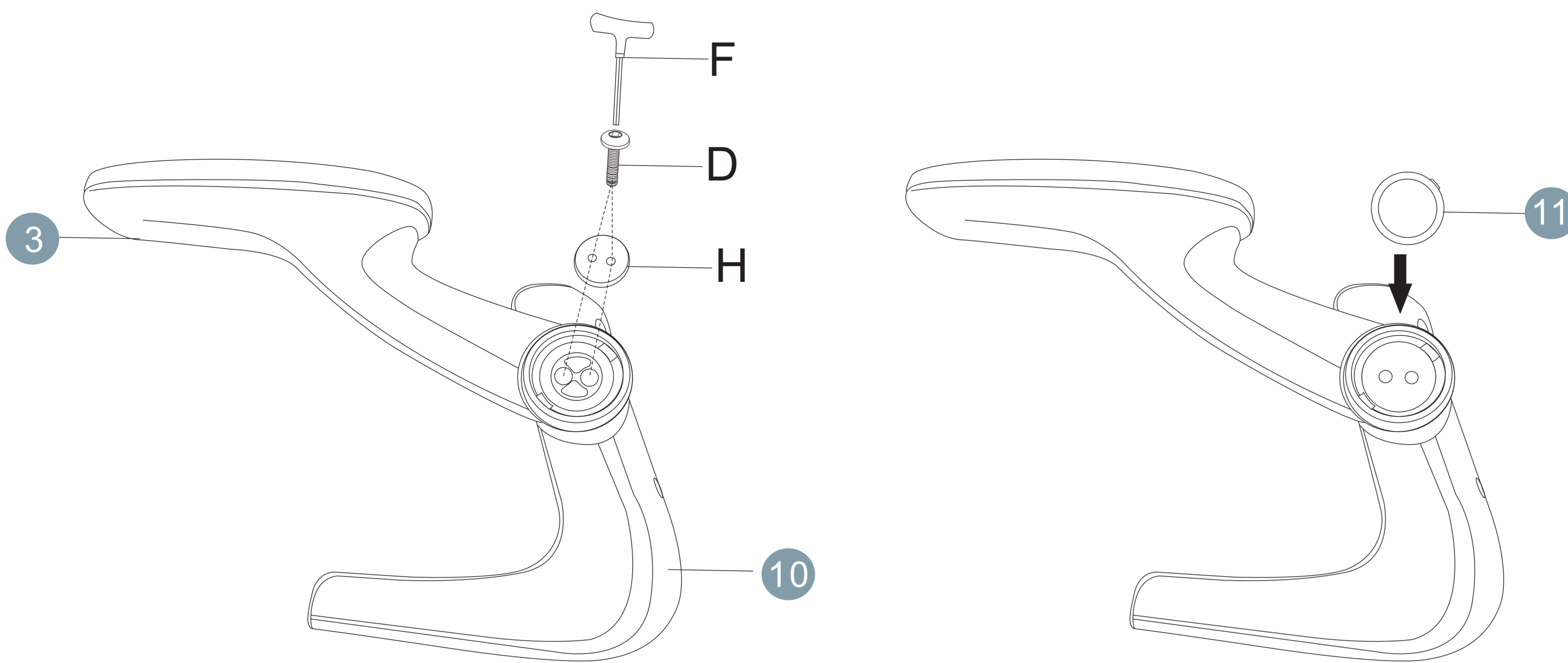

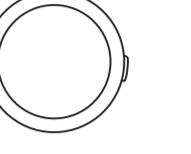
11 x2

3 x2

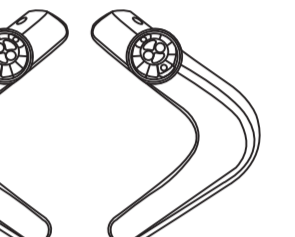
10 x2

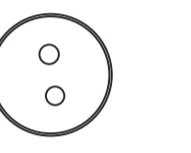

H x2



D x4

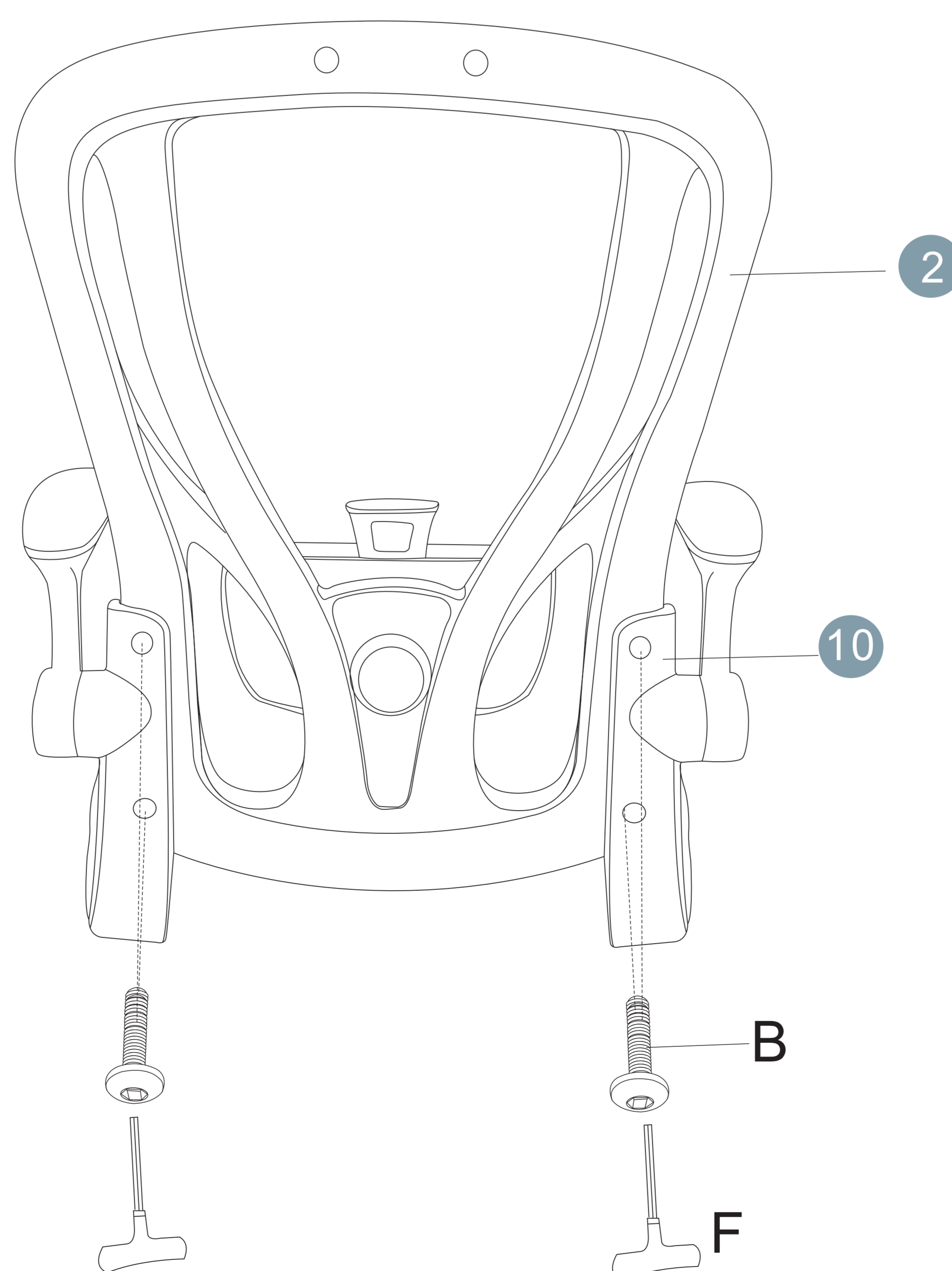

F x1

STEP 4

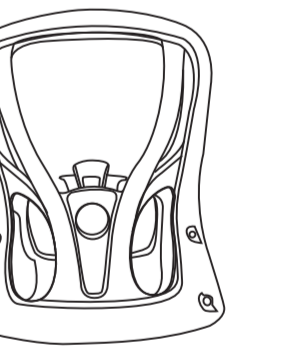
Connect armrest(3) with backrest(2) using the bolts(B). Do NOT fully tighten the bolts until all of them are in the correct holes. This will allow you slight adjustments during the assembly.

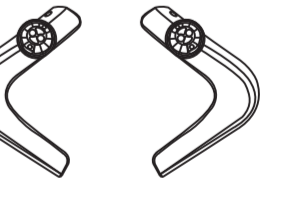

2 x1

10 x2



B x4

F x1

Assembly Instruction

STEP 5

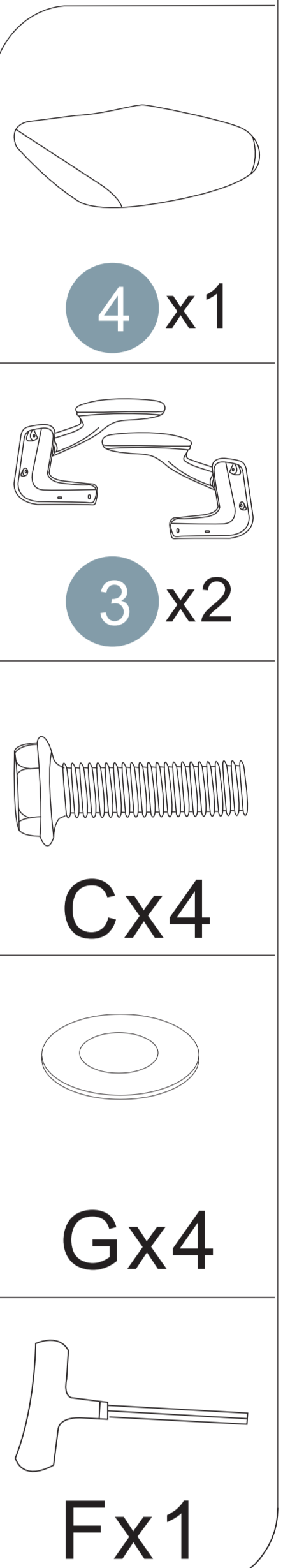
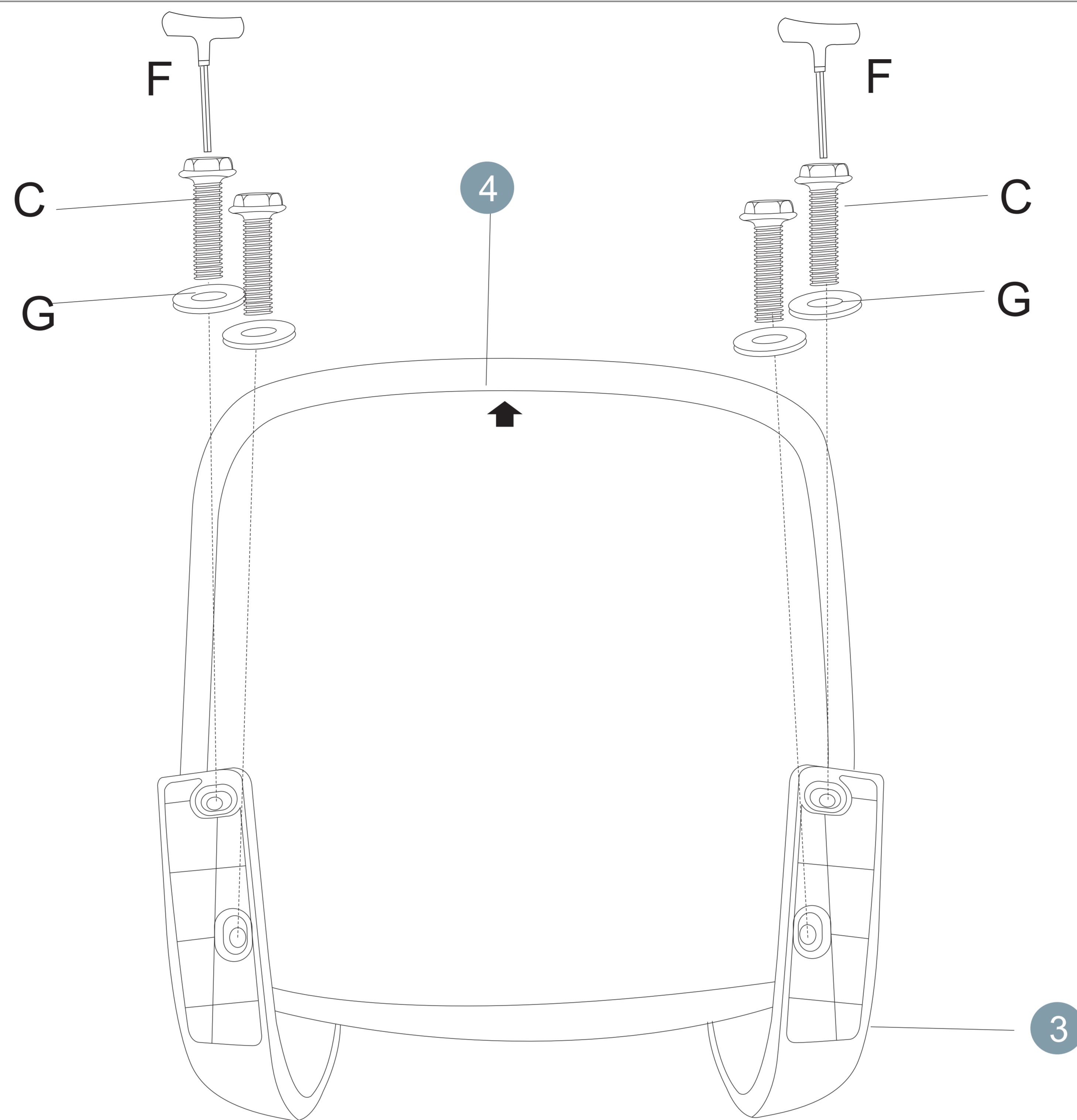
Connect armrest(3) with seat pan(4) using the bolts(C) and washers(G). Do NOT fully tighten the bolts until all of them are in the correct holes. This will allow you slight adjustments during the assembly.



STEP 6

Connect mechanism(5) with seat pan(4) using the bolts(A) and washers(G). Do NOT fully tighten the bolts until all of them are in the correct holes. This will allow you slight adjustments during the assembly.

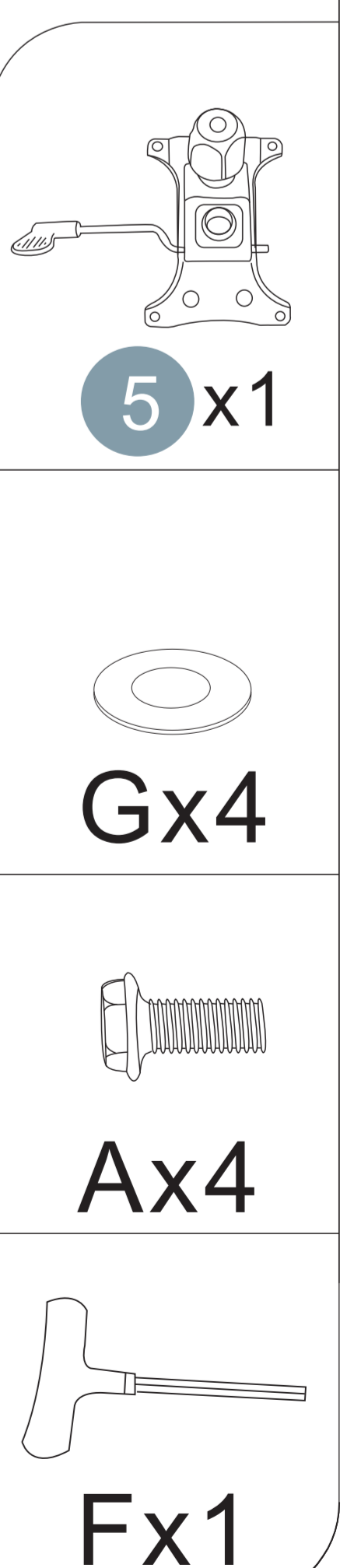
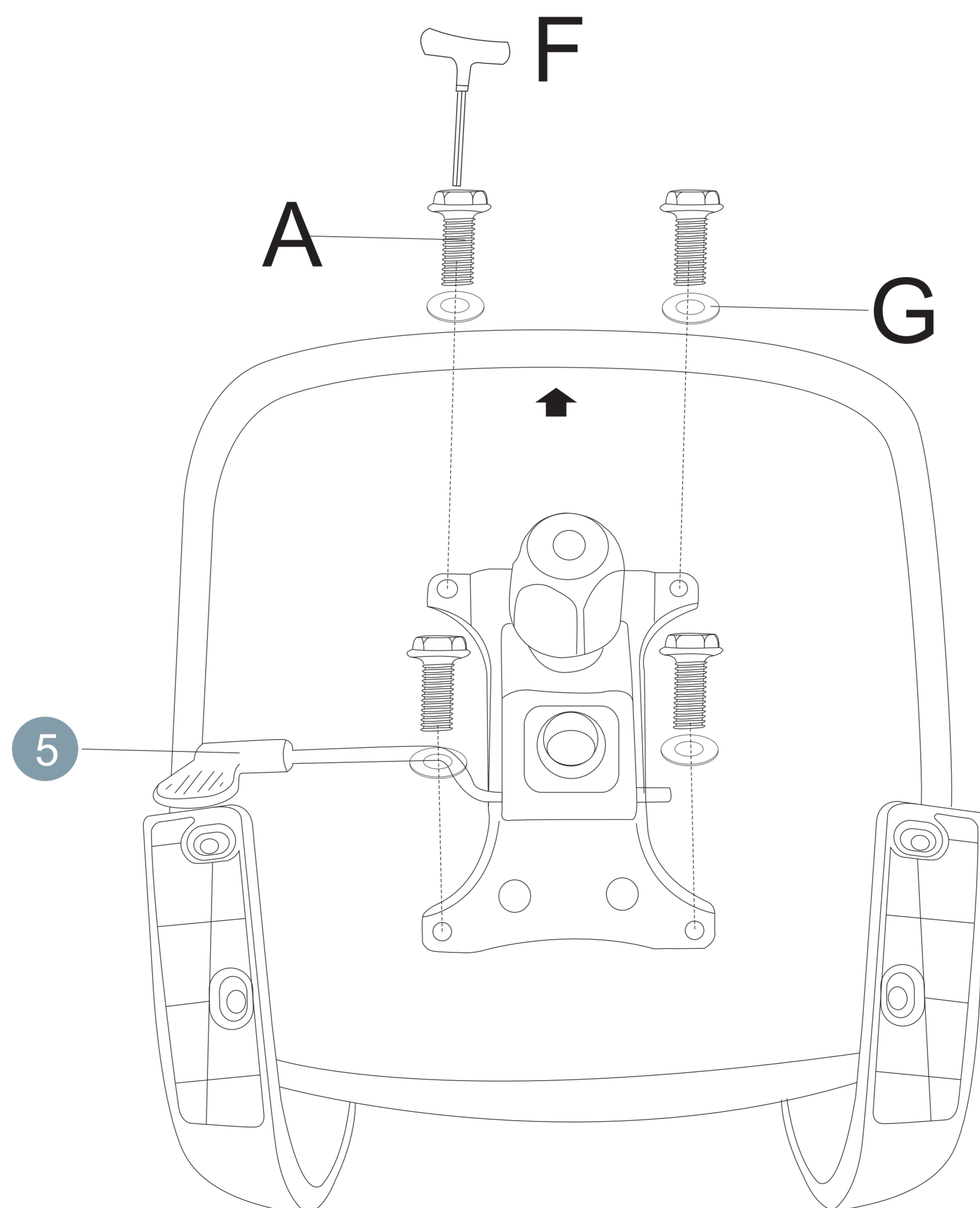

Assembly Instruction

STEP 7

Now, connect the assembled seat cushion with gas lift(6) and press firmly until it is securely attached.

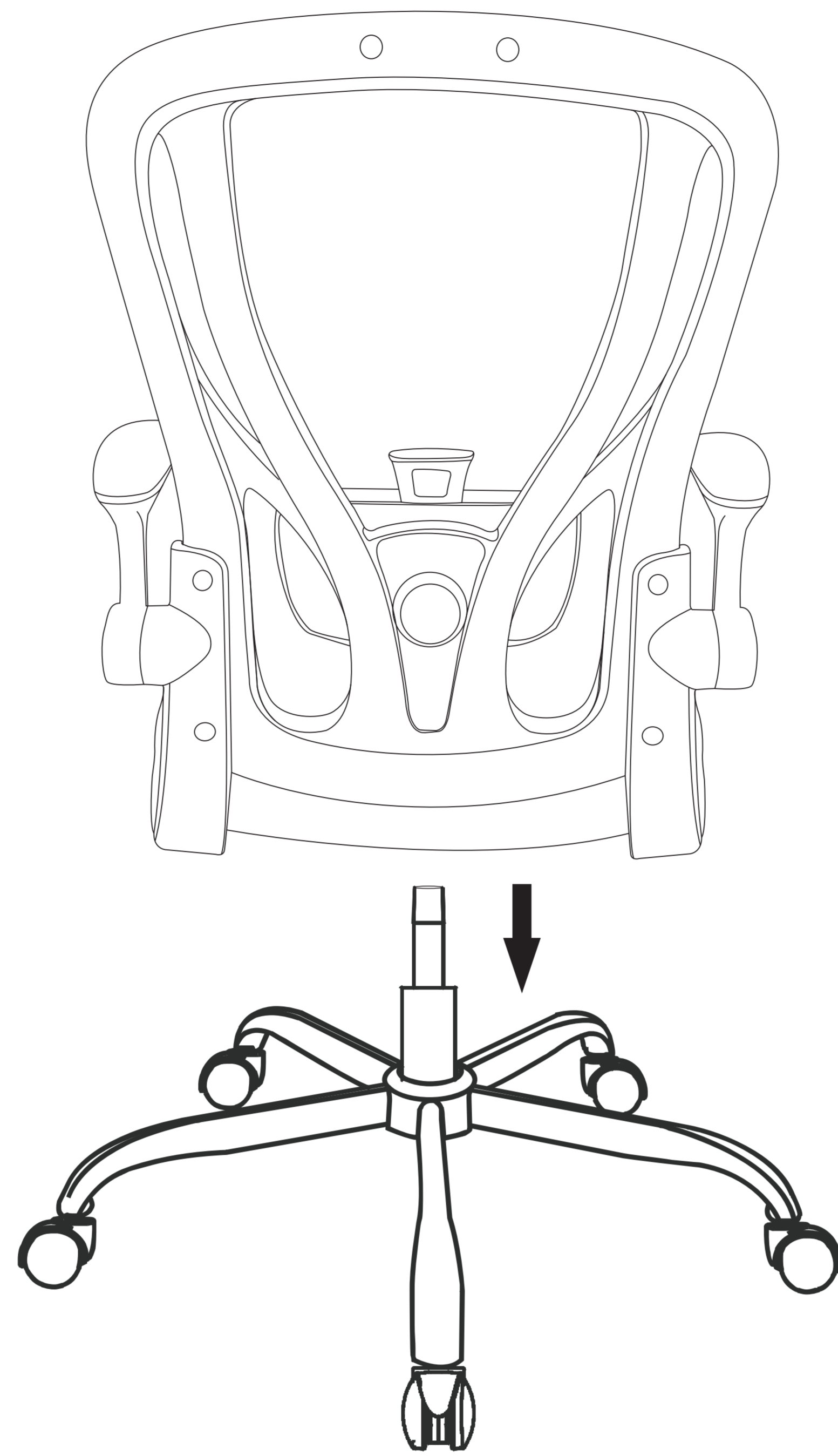

STEP 8

Connect headrest(1) with backrest(2) using the bolts(B). Do NOT fully tighten the bolts until all of them are in the correct holes. This will allow you slight adjustments during the assembly.

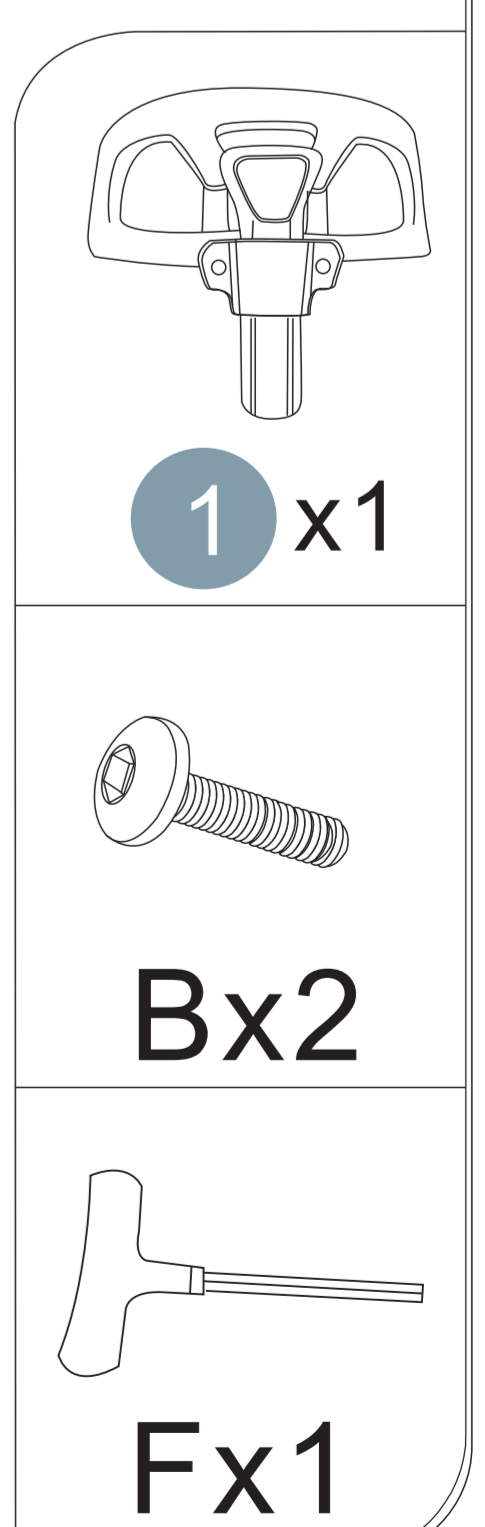
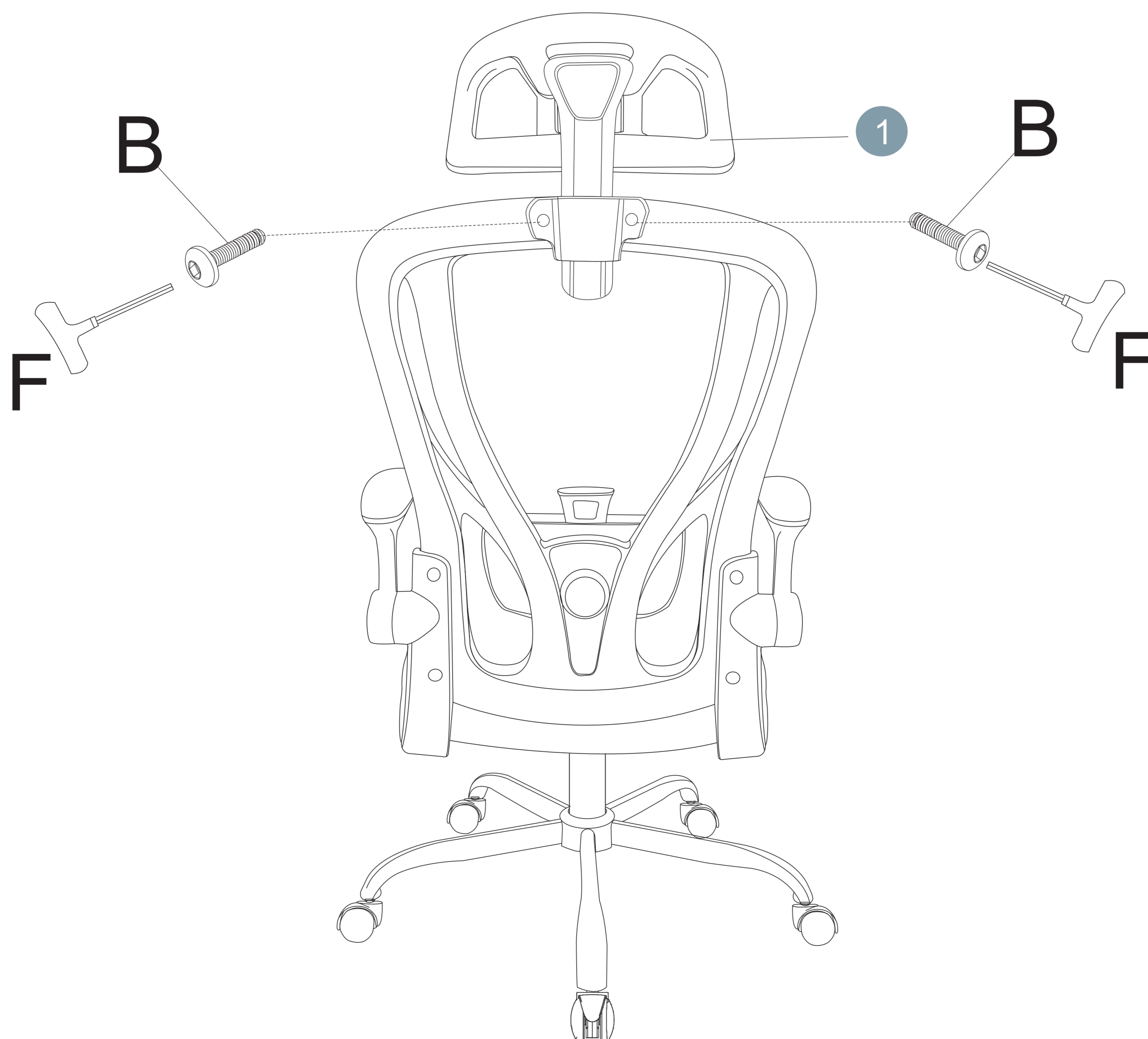

Assembly Instruction

STEP 9

The assembly is done.

Done!

