

Installation & Assembly

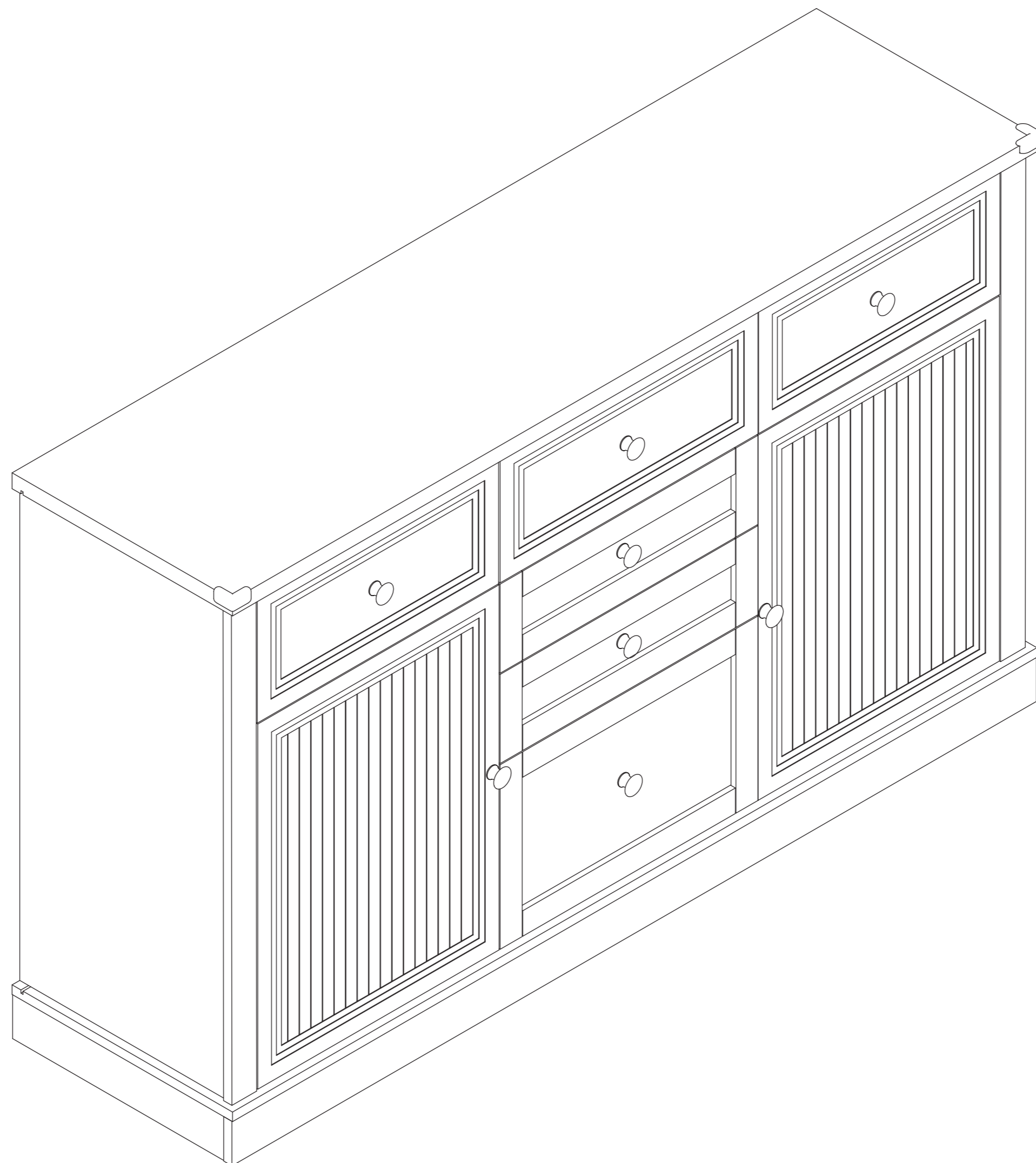

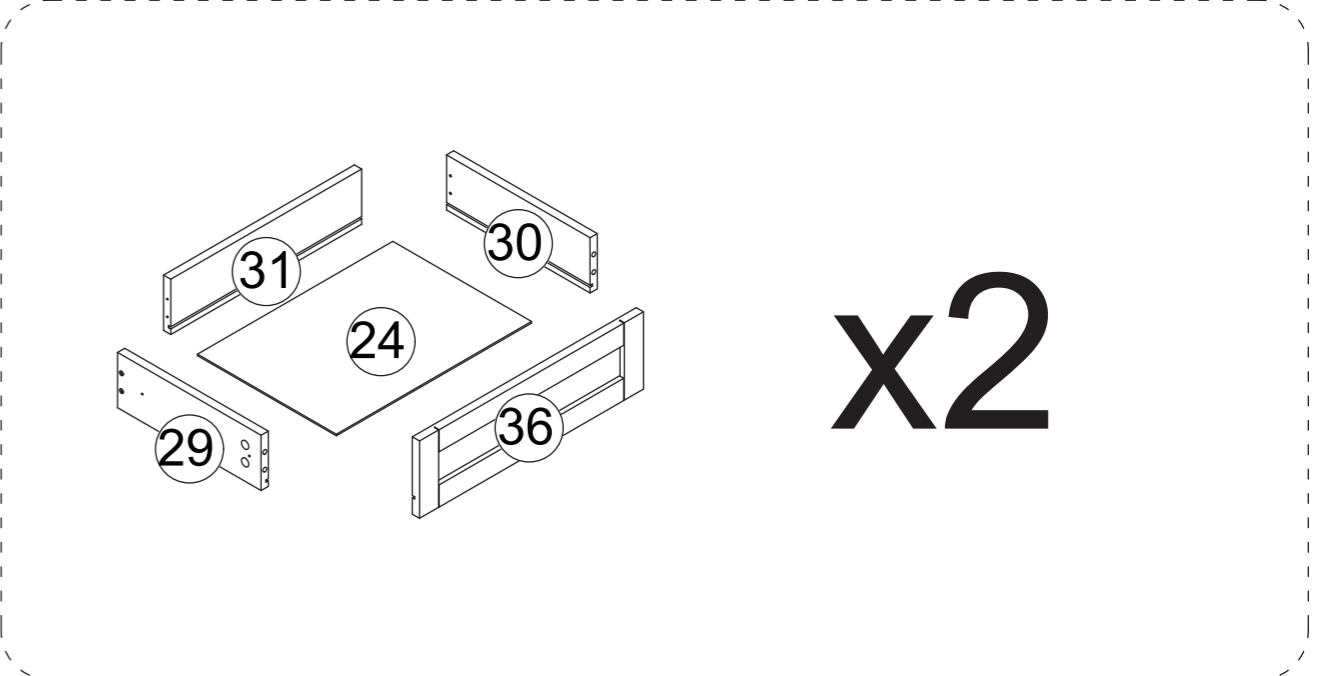

EXPLODED DRAWING:

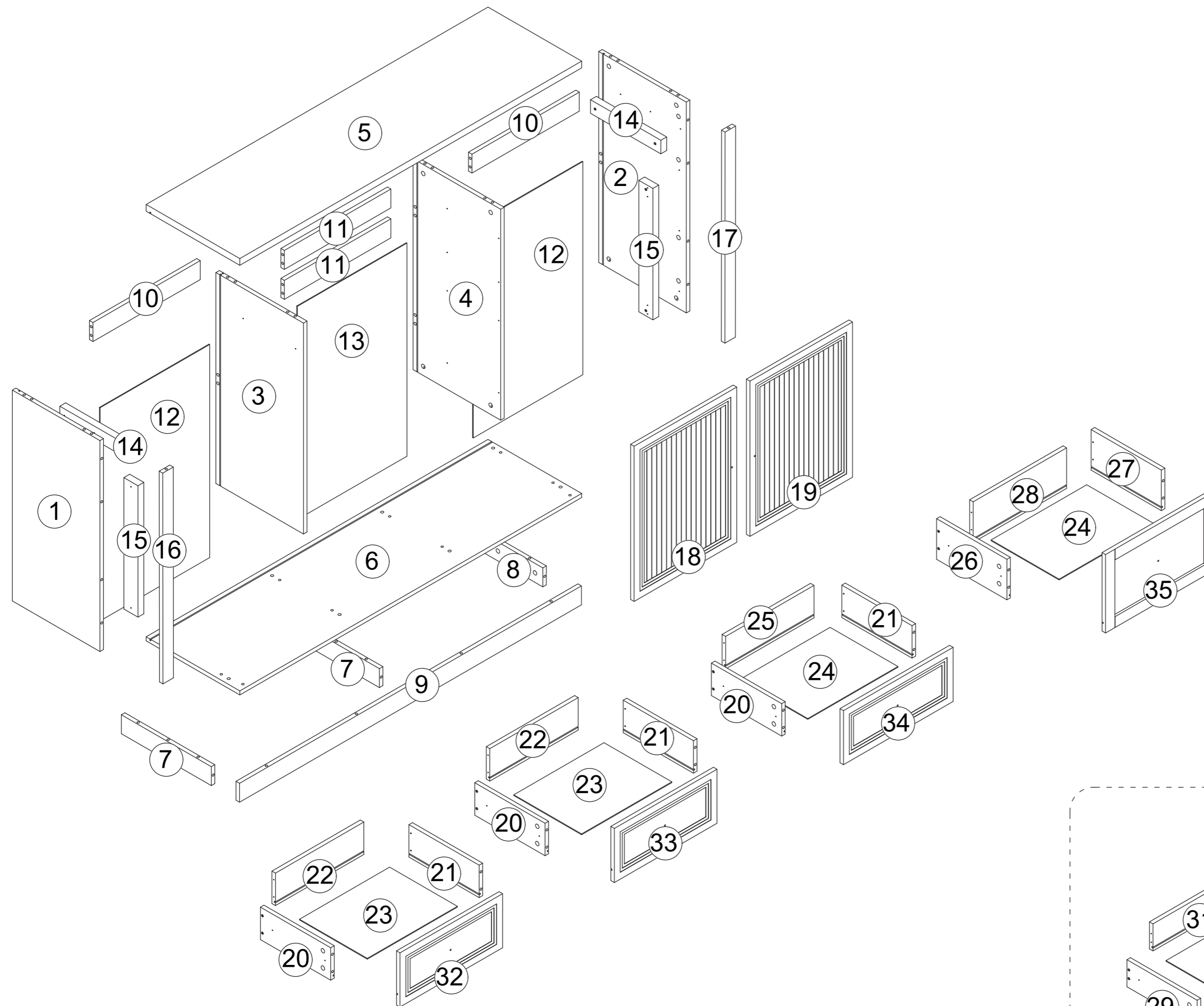

x2

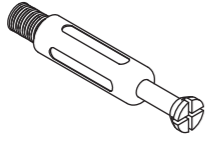
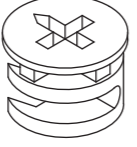
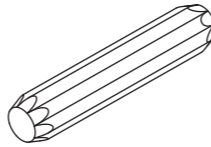
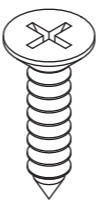
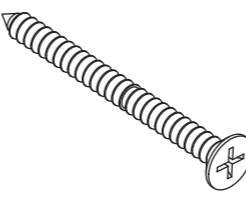
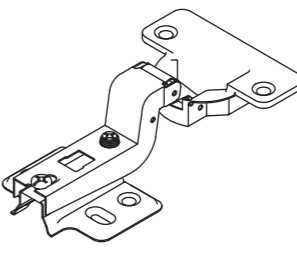
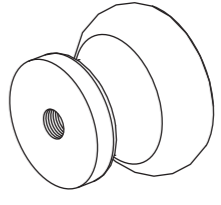
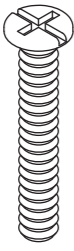
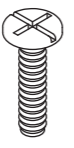
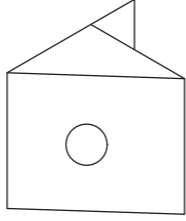
PARTS:

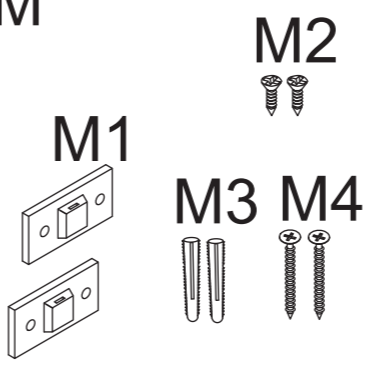
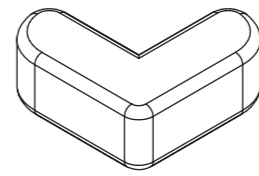
<p>A 40MM</p>  <p>x80</p>	<p>B 15*12</p>  <p>x80</p>	<p>C Ø8*40</p>  <p>x20</p>	<p>D Ø3.5*14</p>  <p>x64</p>	<p>E Ø3.5*35</p>  <p>x36</p>	<p>F</p>  <p>x4</p>	<p>G</p>  <p>x8</p>
<p>H Ø4*18</p>  <p>x2</p>	<p>I Ø4*15</p>  <p>x6</p>	<p>K</p>  <p>x28</p>	<p>L Ø3.5*12</p>  <p>x28</p>	<p>M</p>  <p>x2</p>	<p>N</p>  <p>x2</p>	

J = **J1** + **J2**

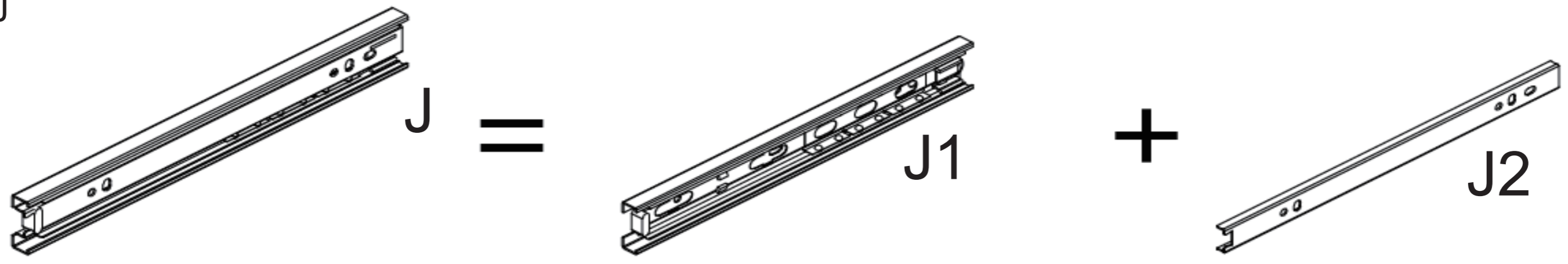

X6

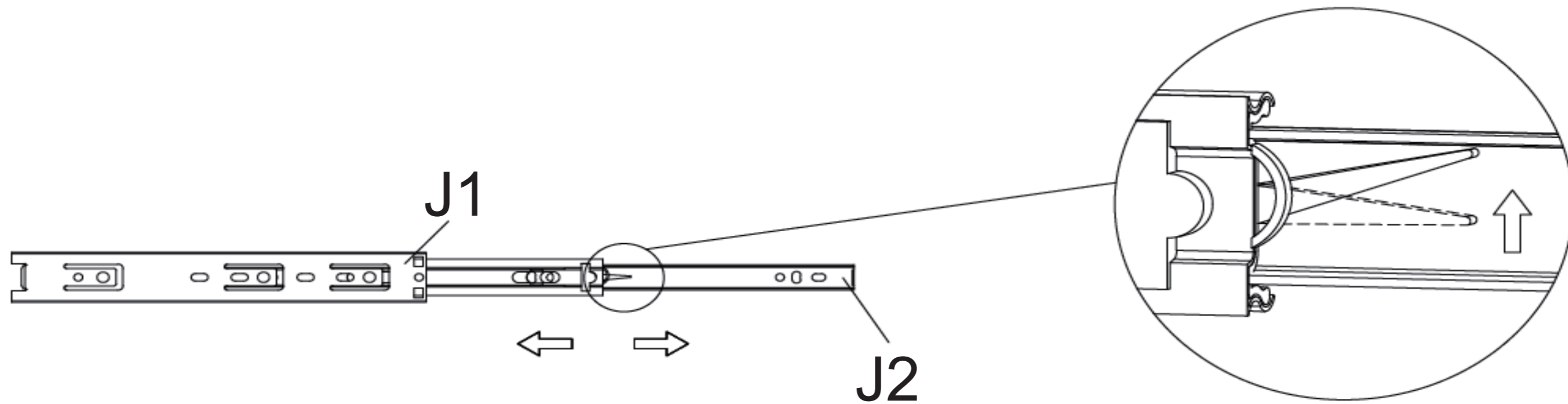

1

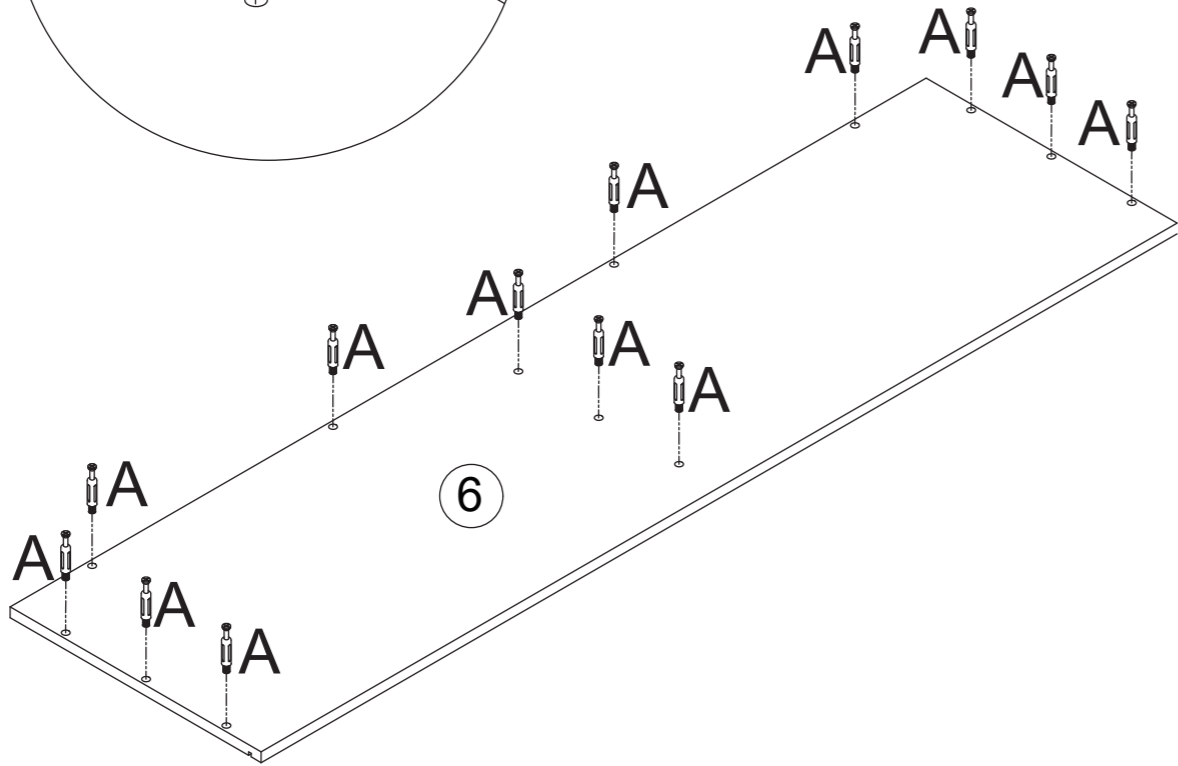
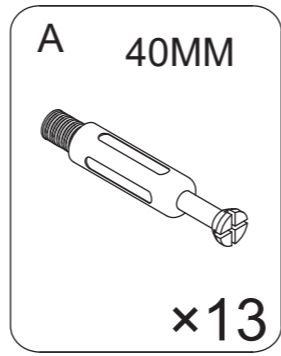
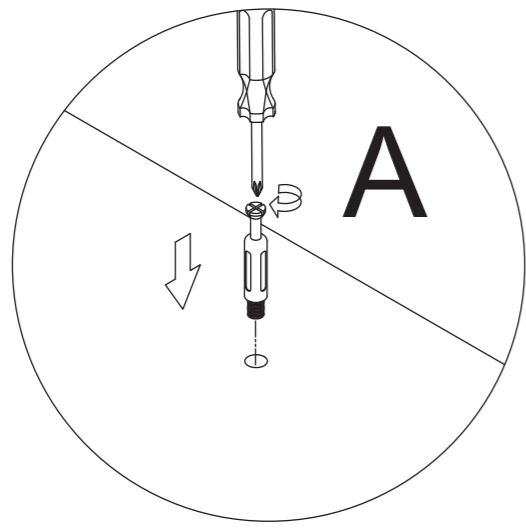

2

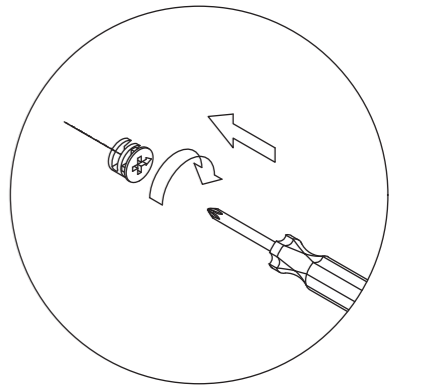
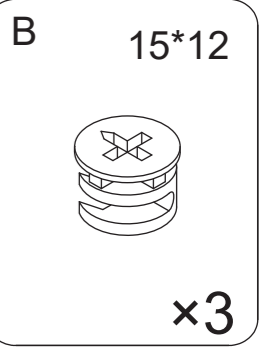
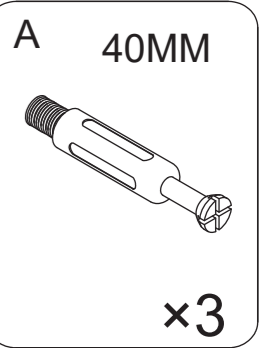
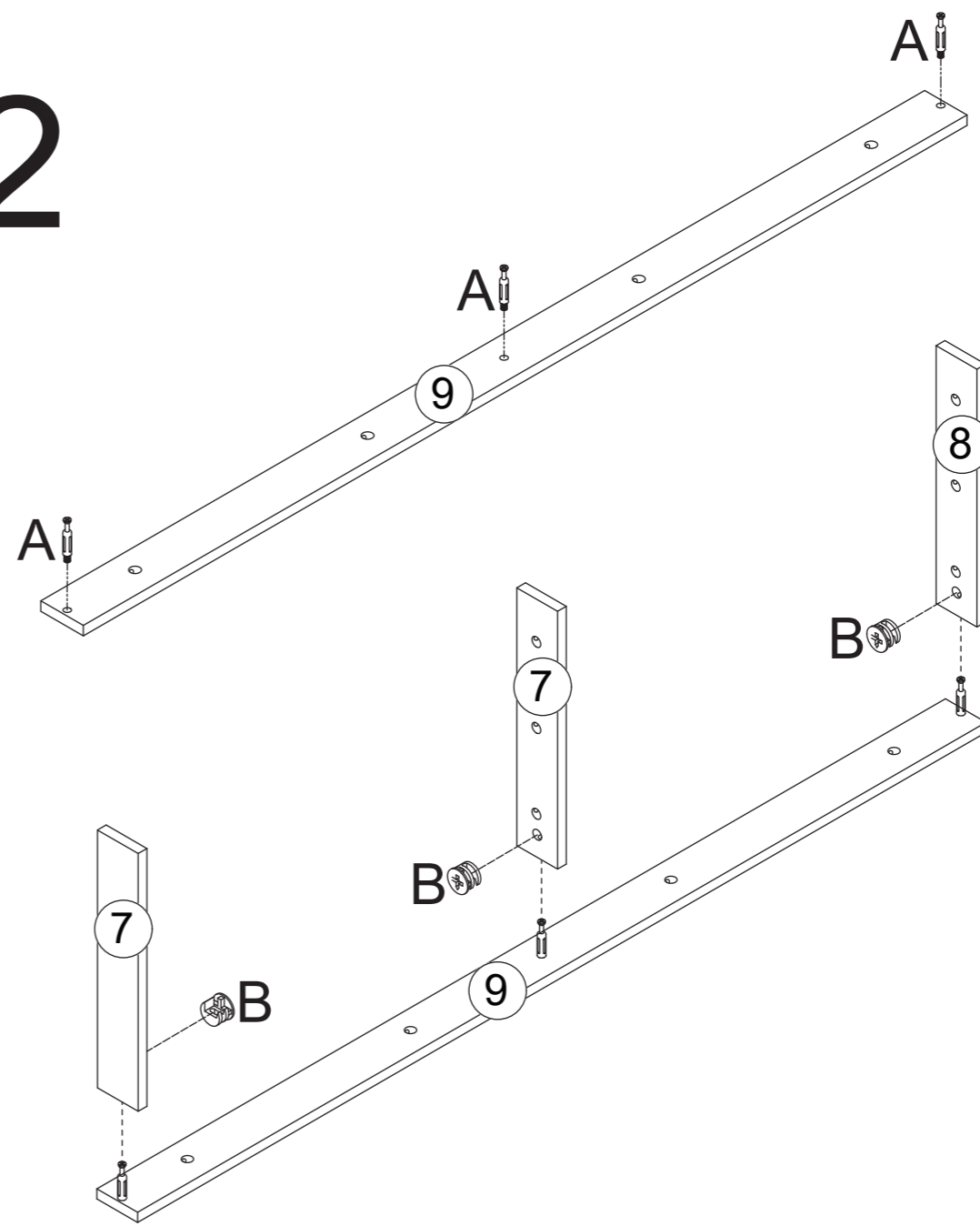

3

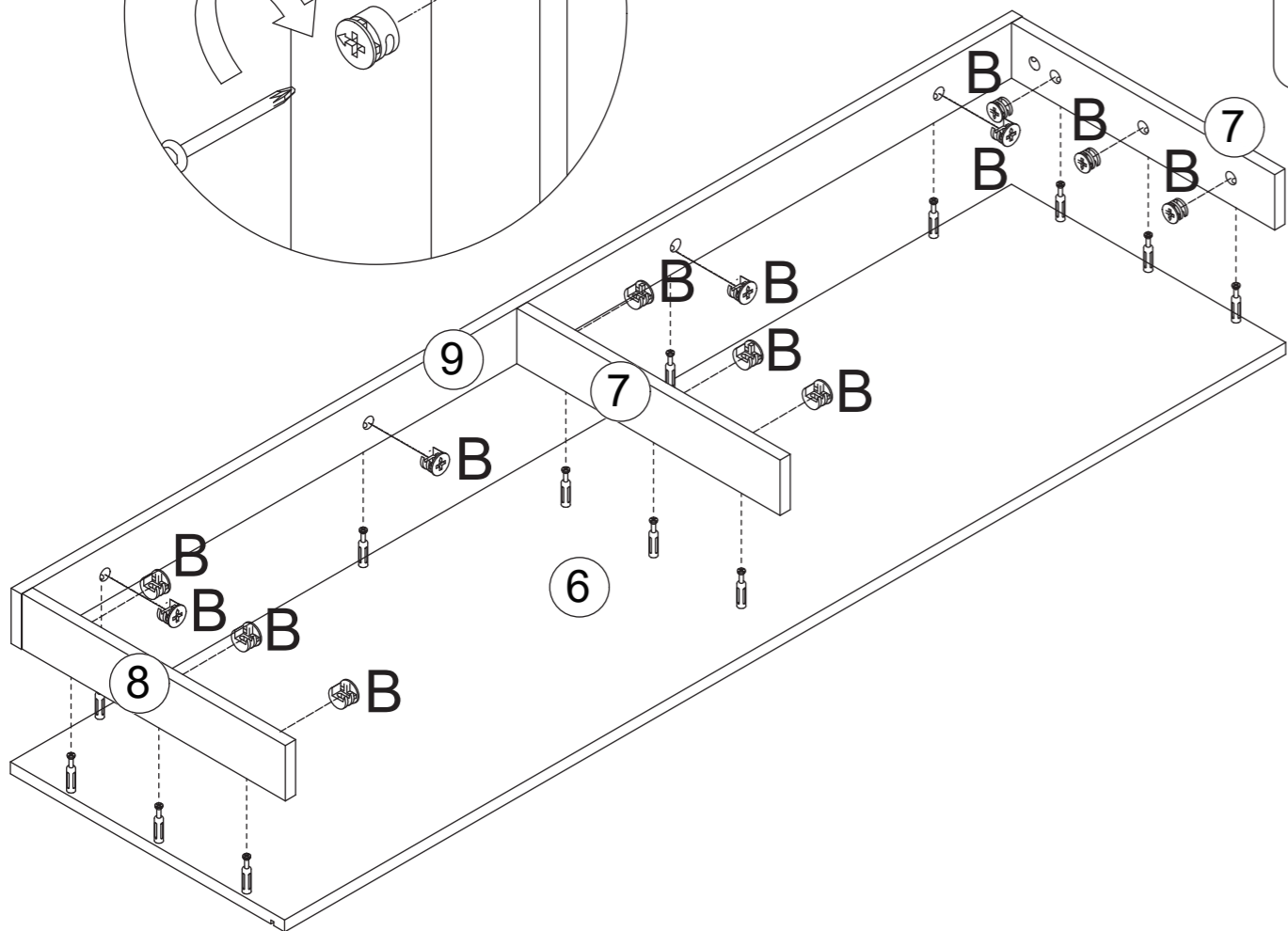
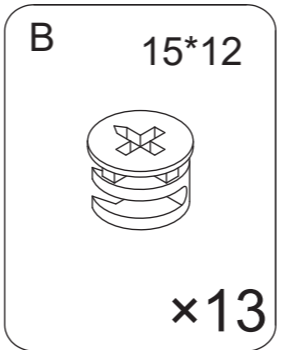
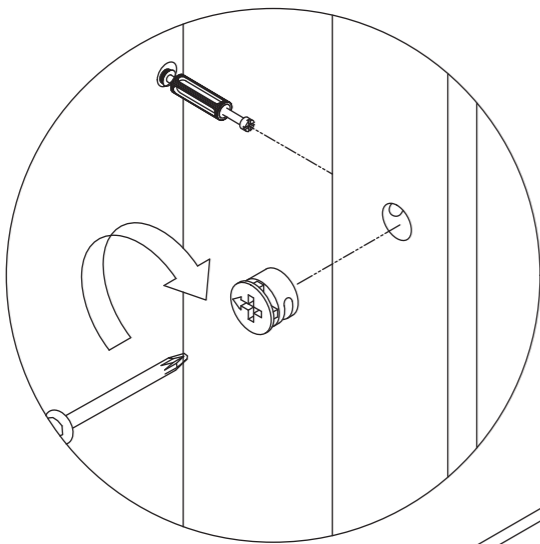

4

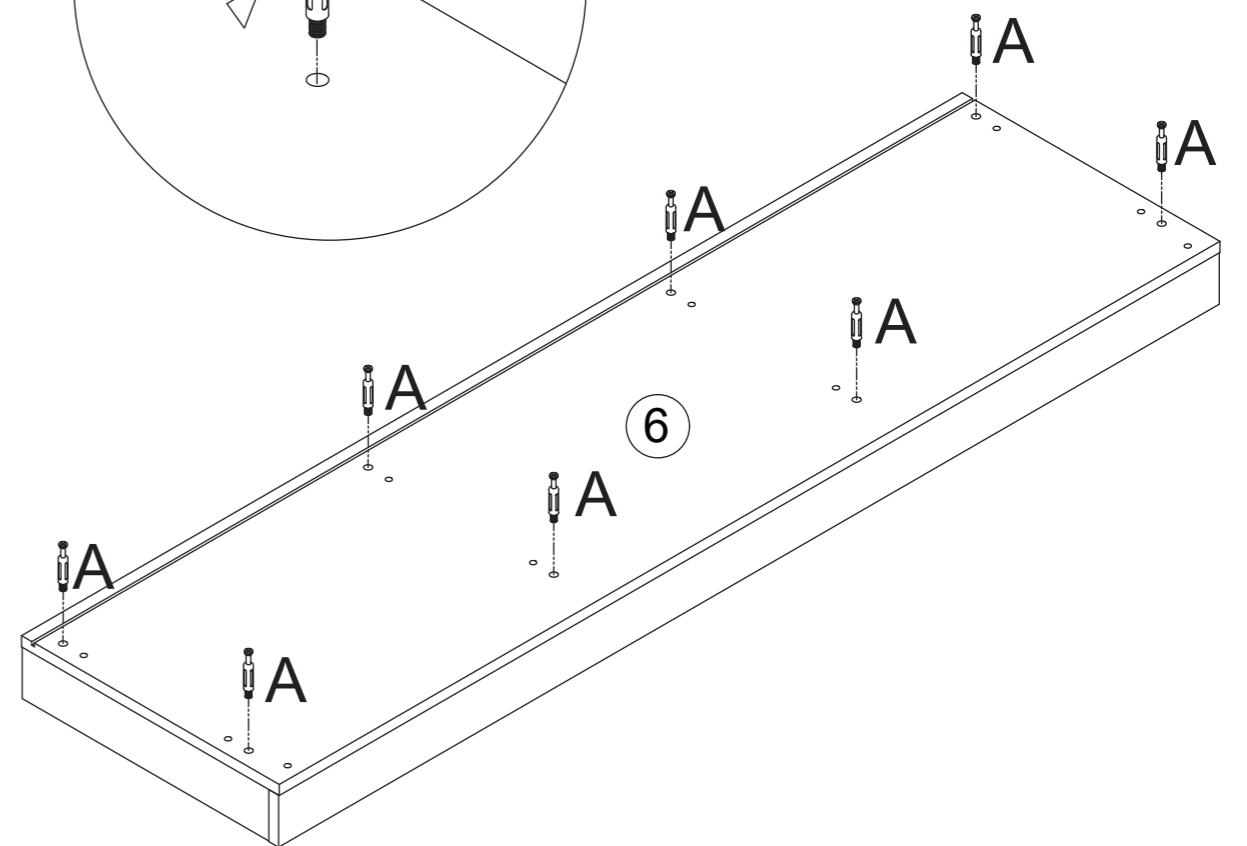
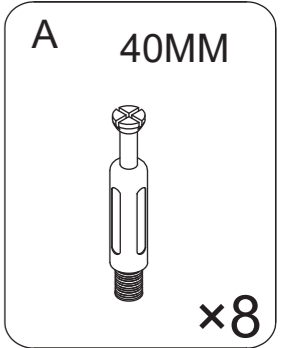
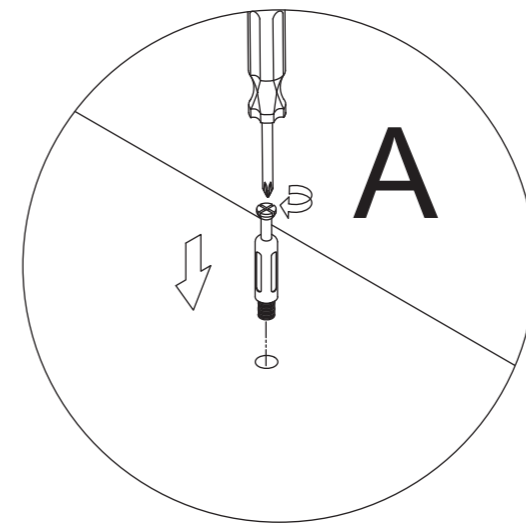

5

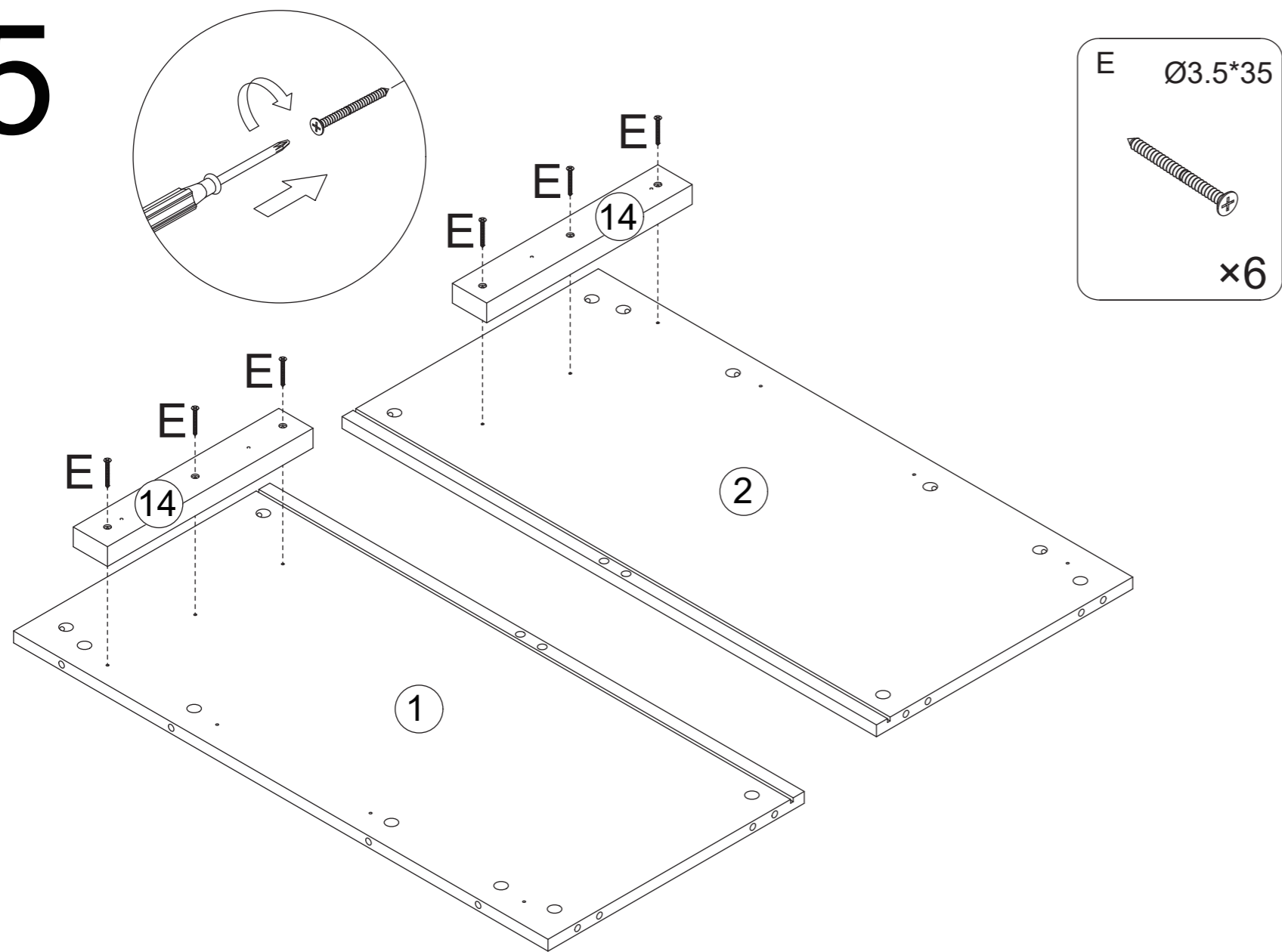

6

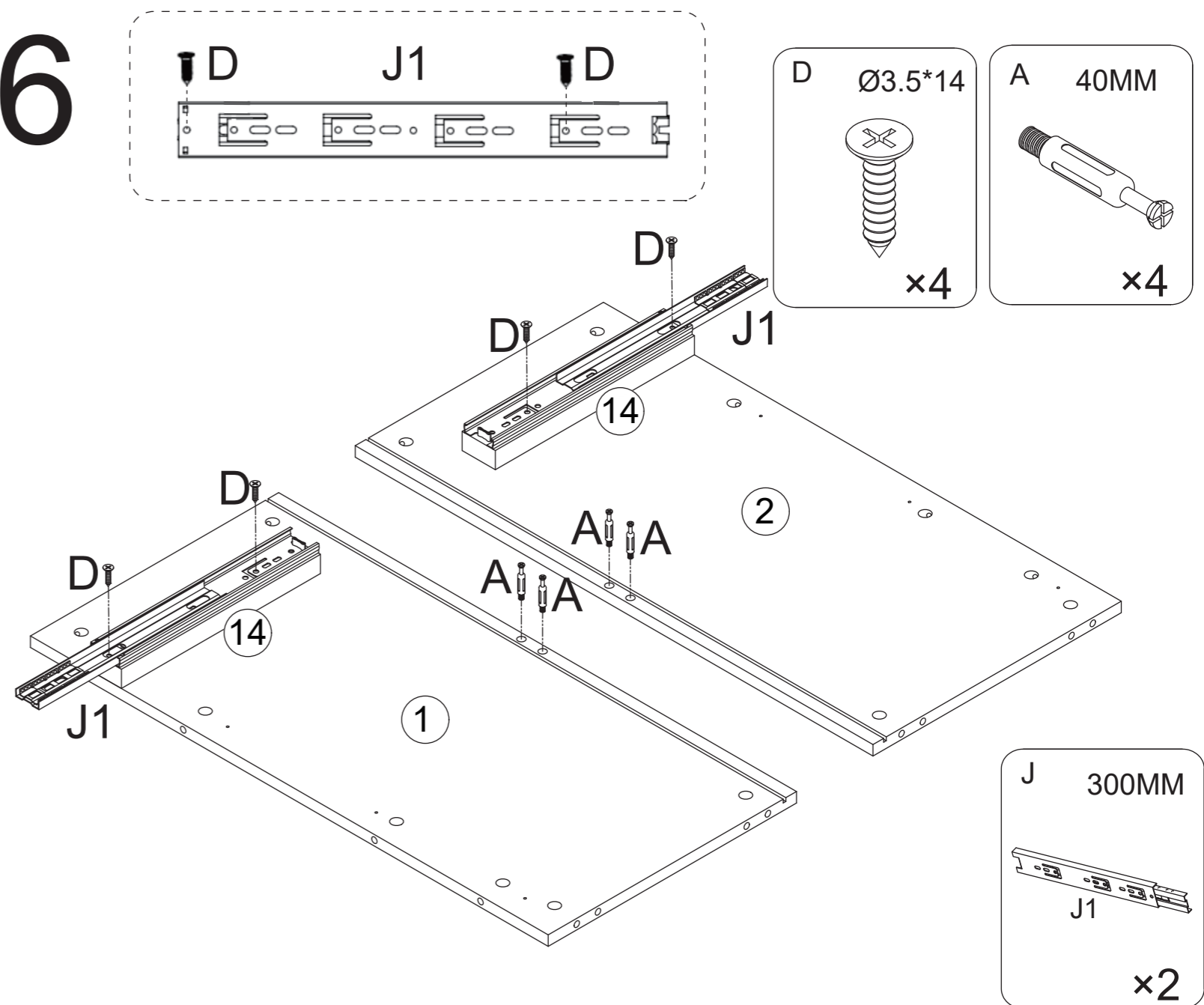

7

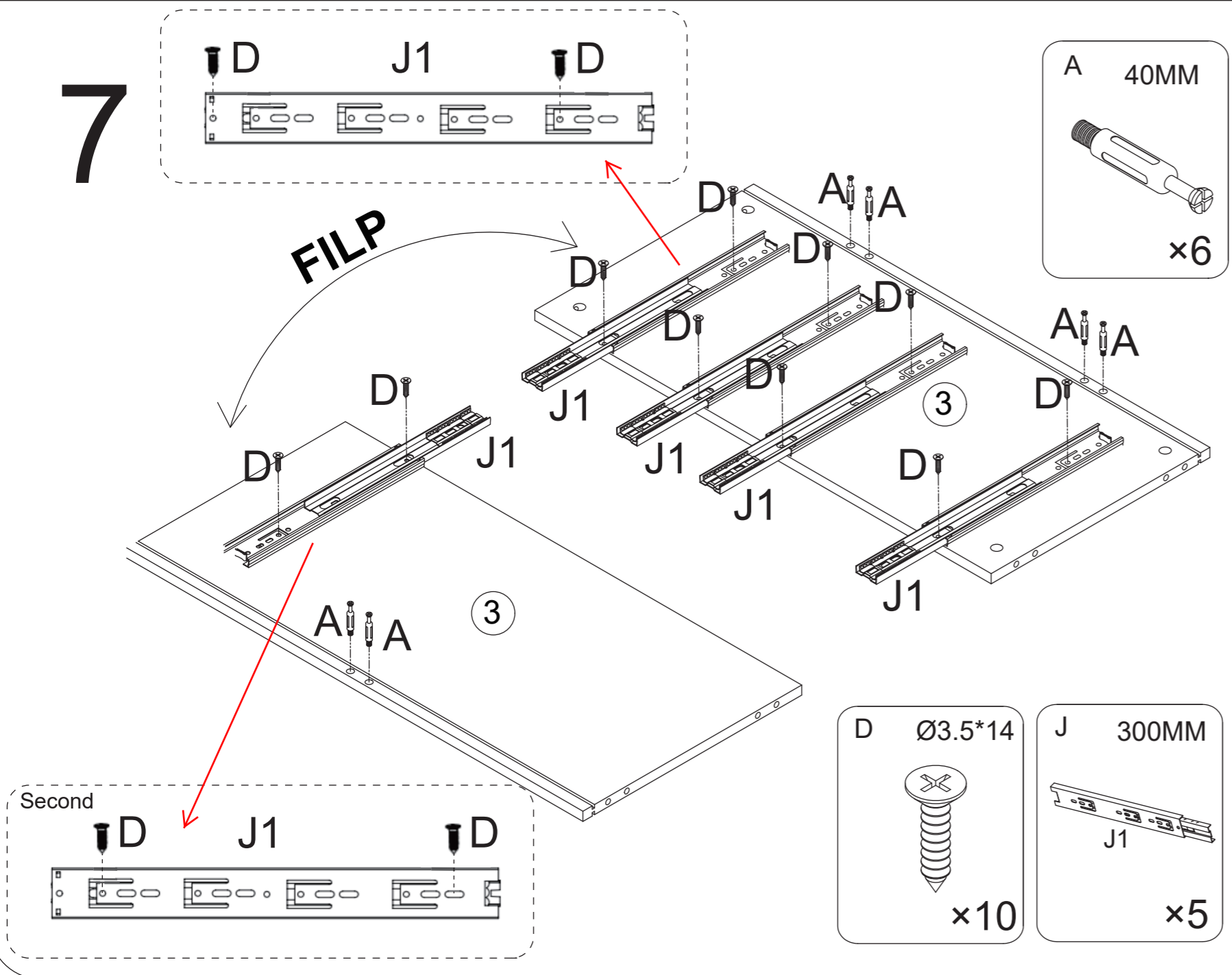

8

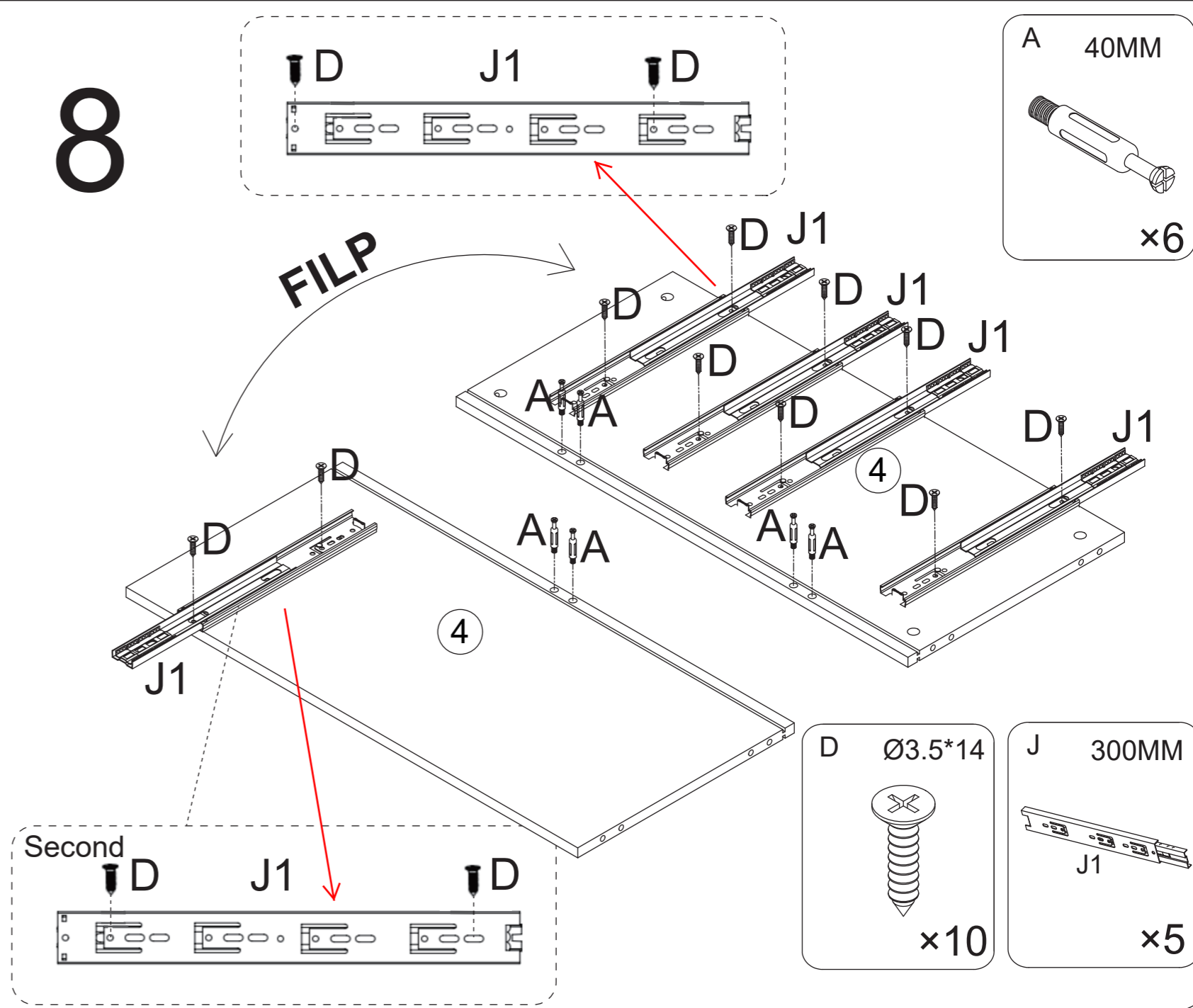

9

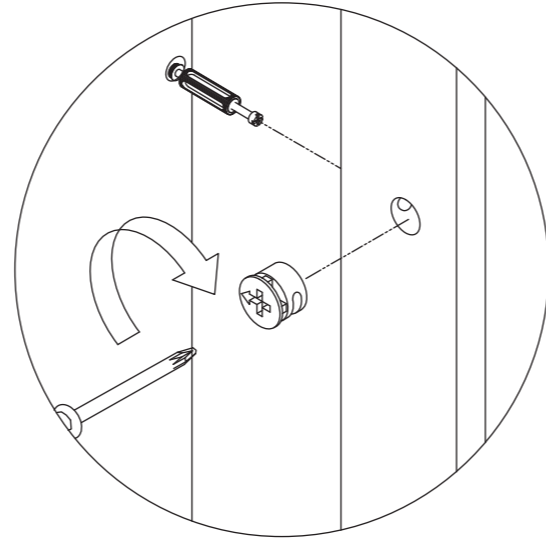
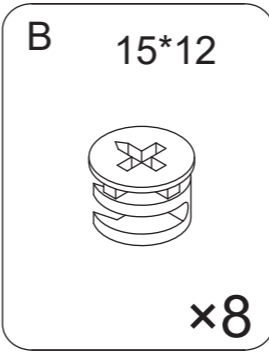
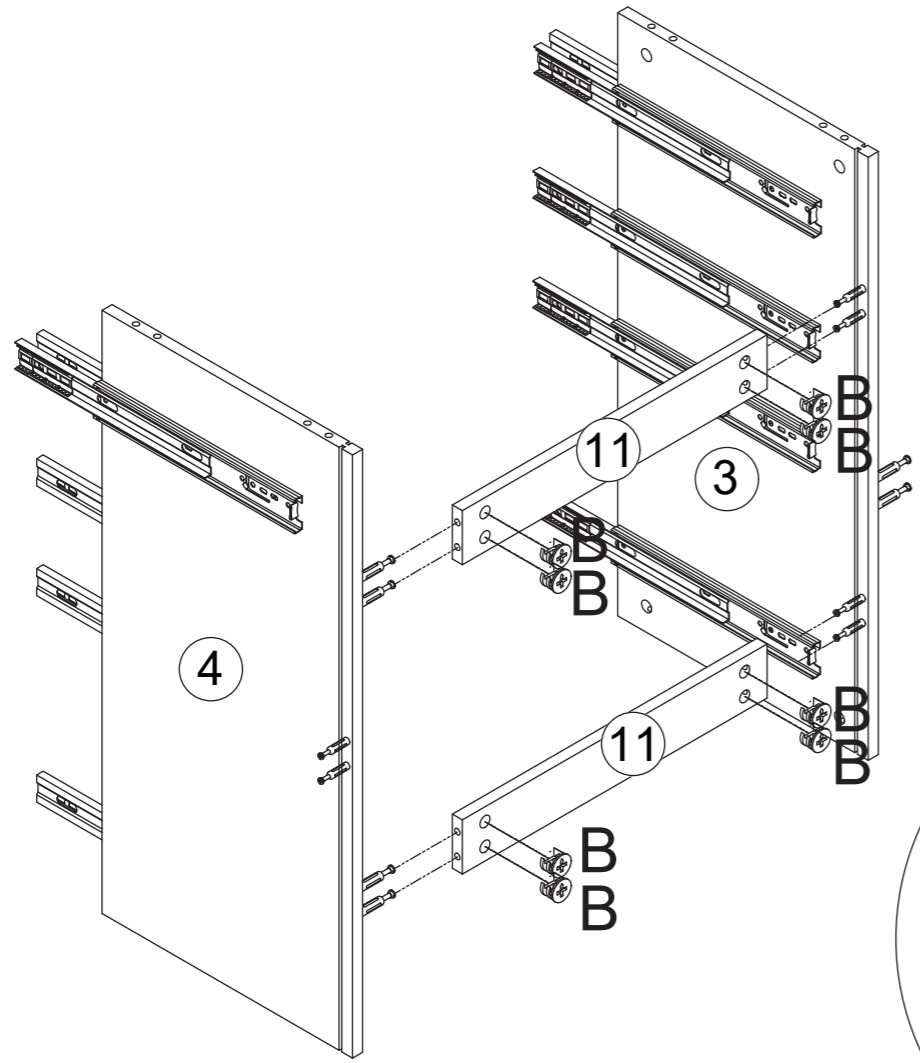

10

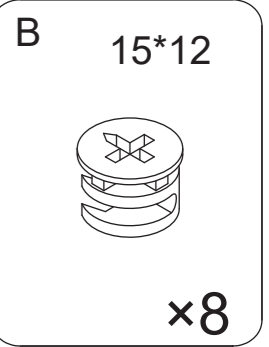
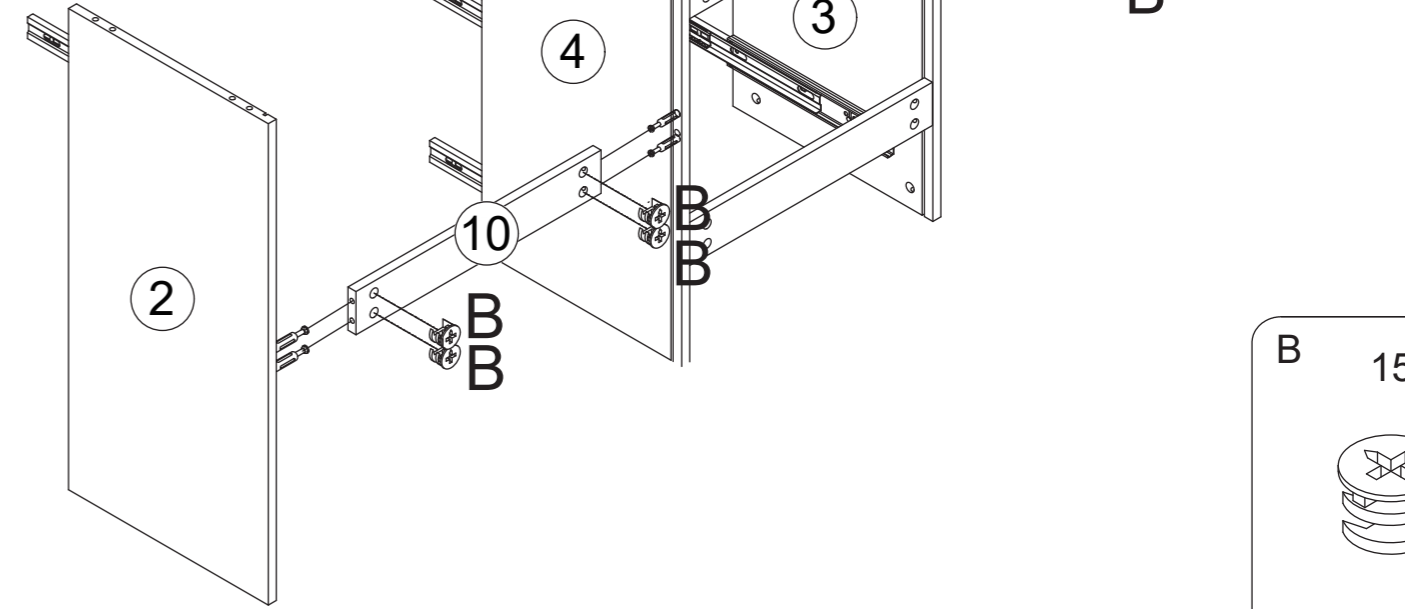

11

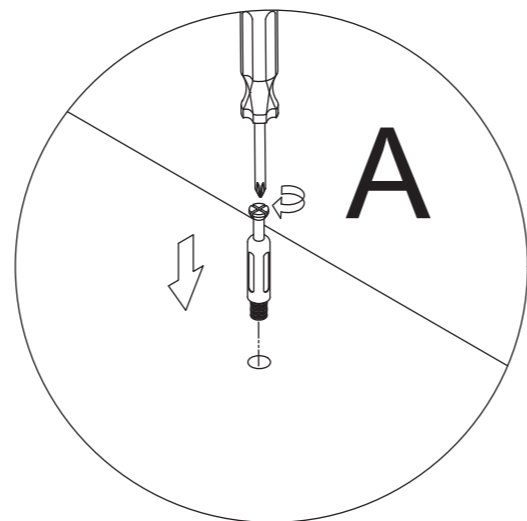
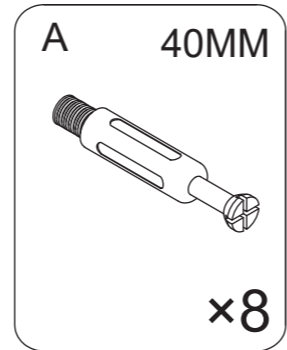
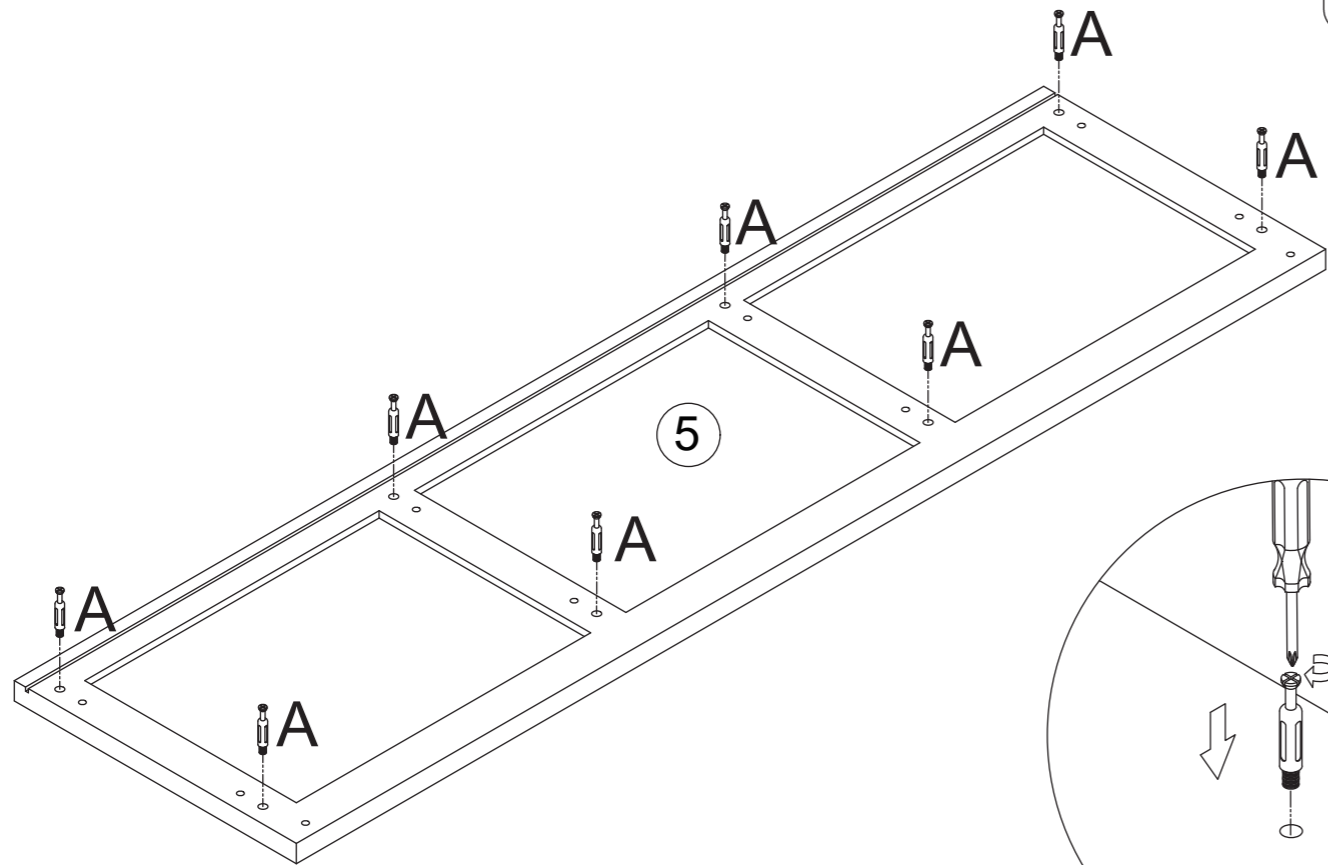

12

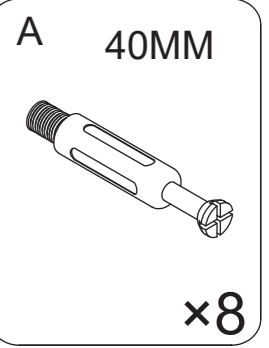
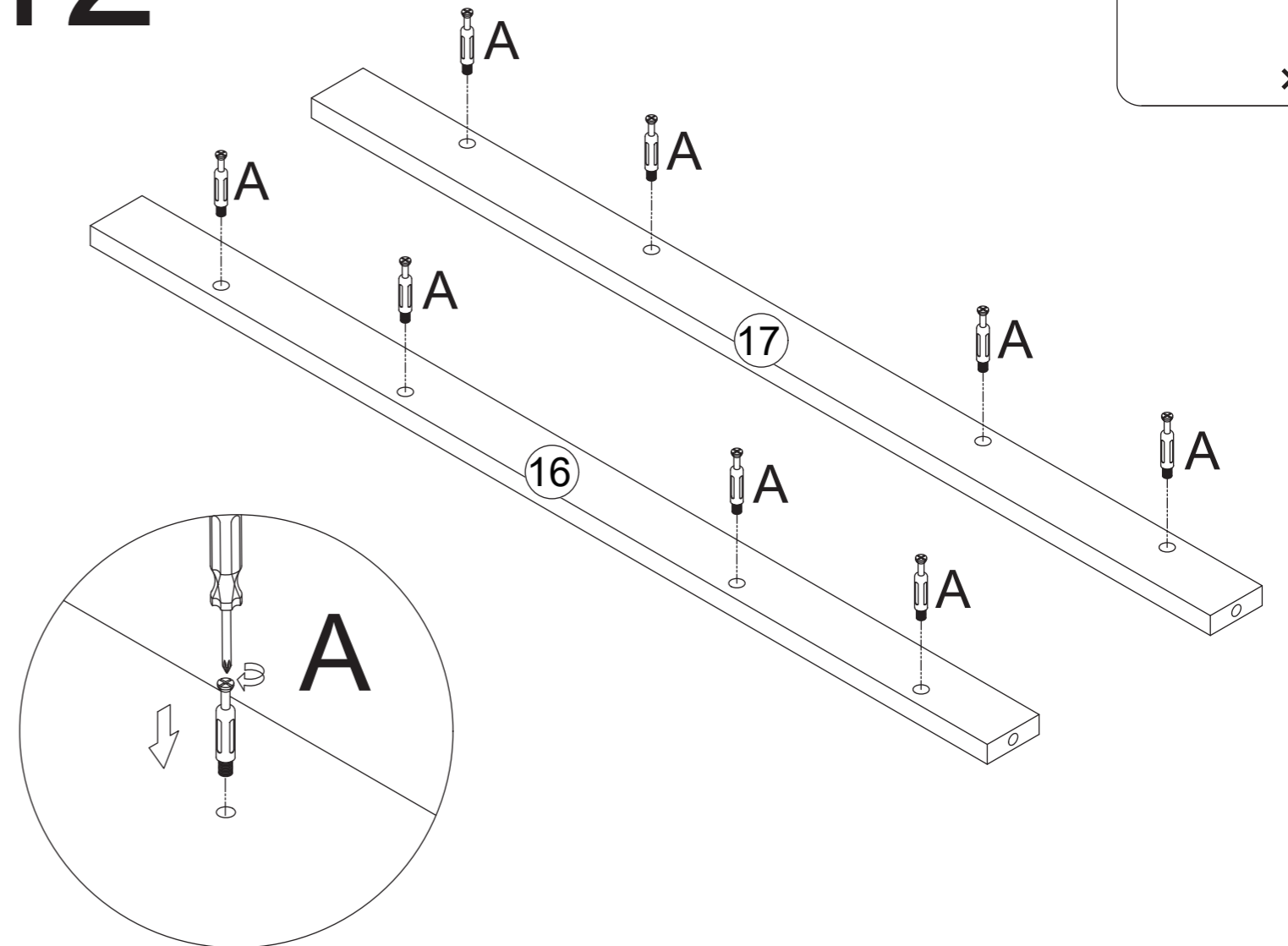

13

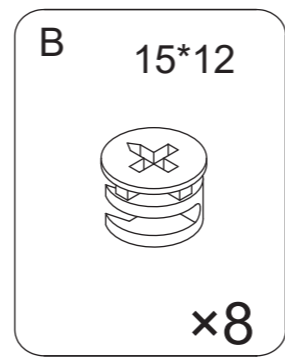
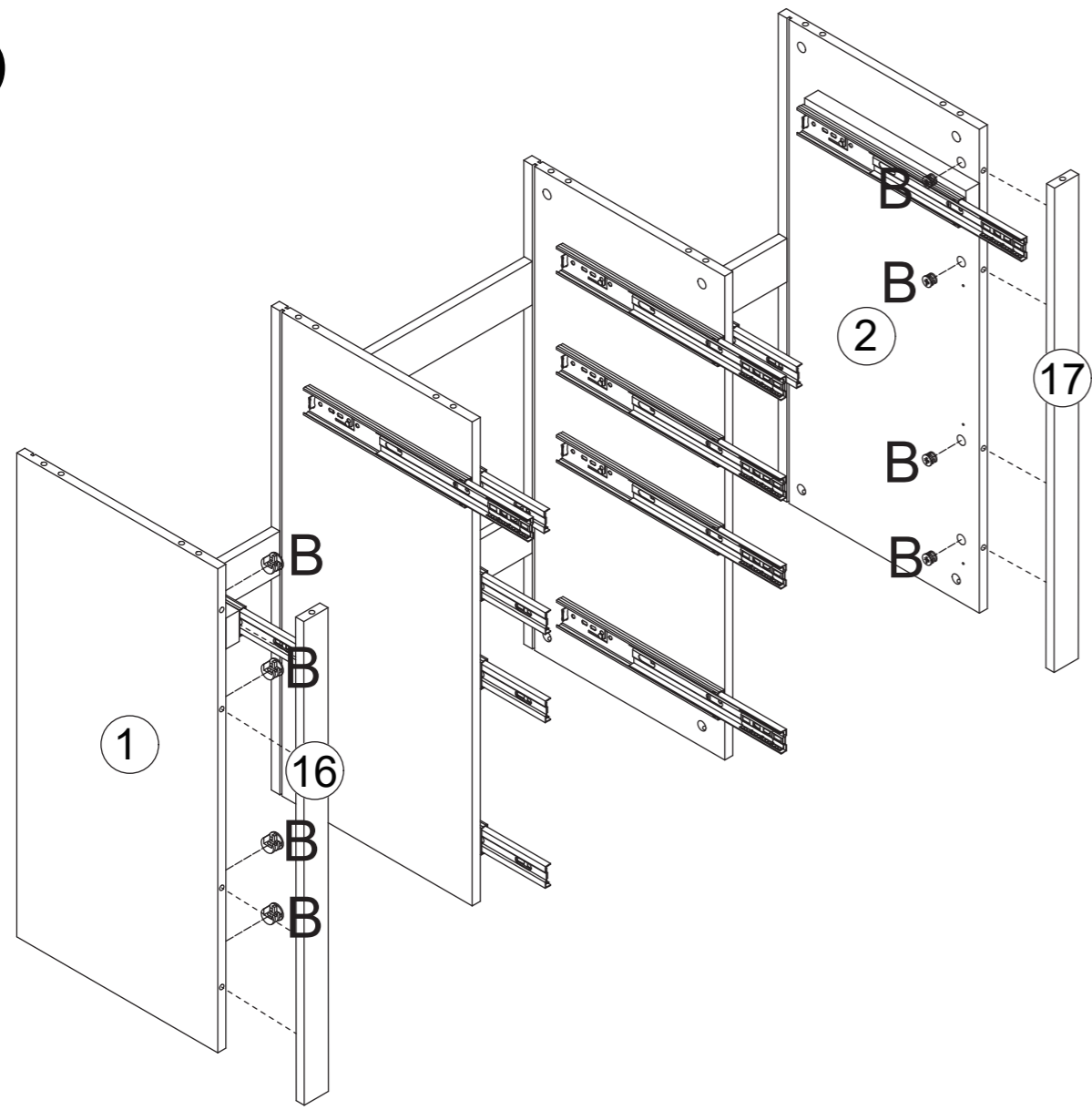

14

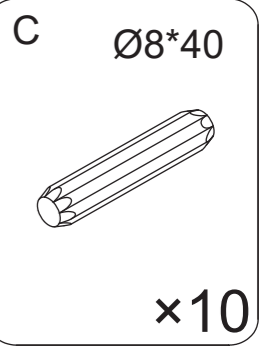
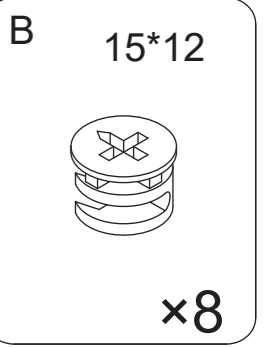
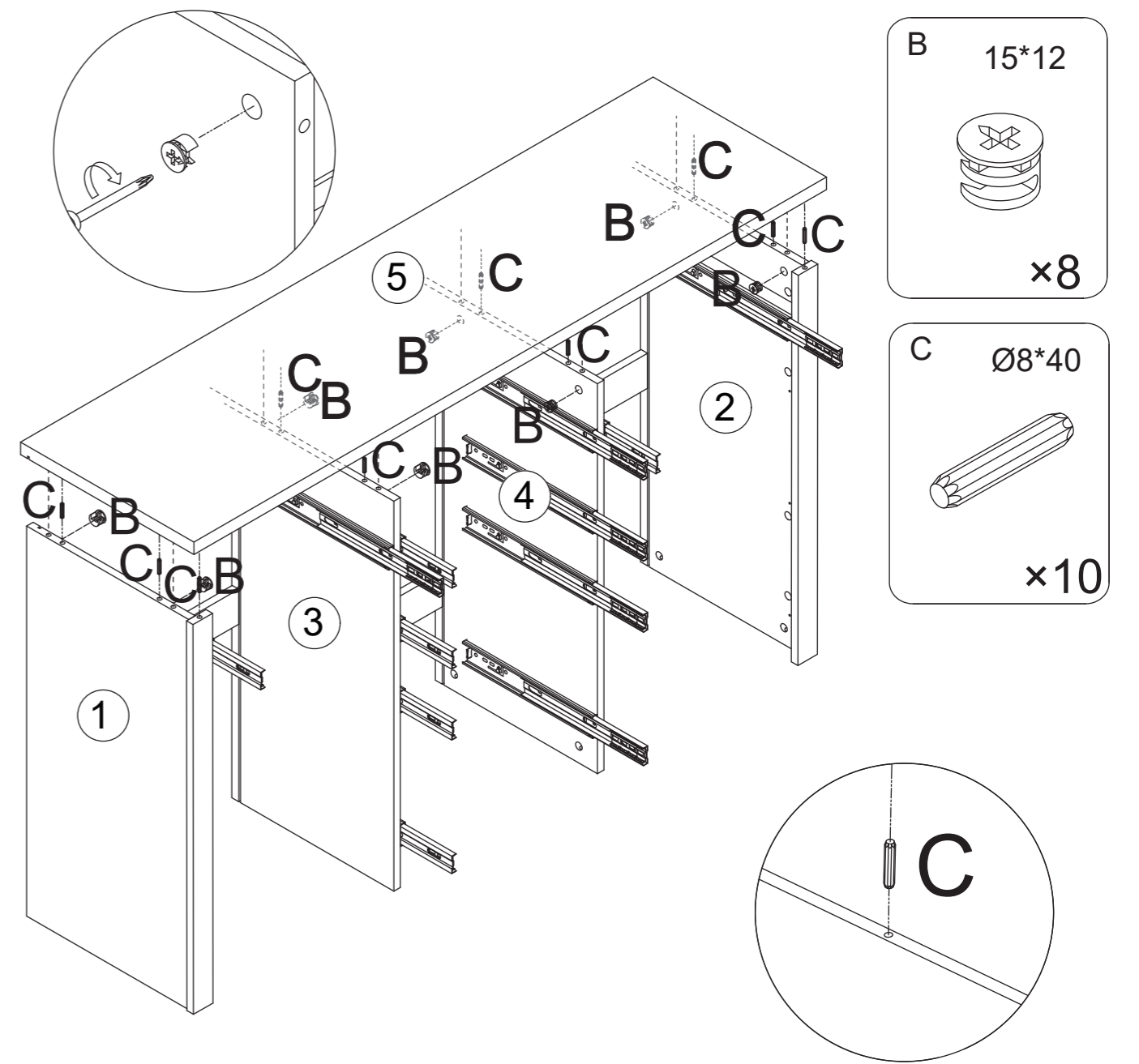

15

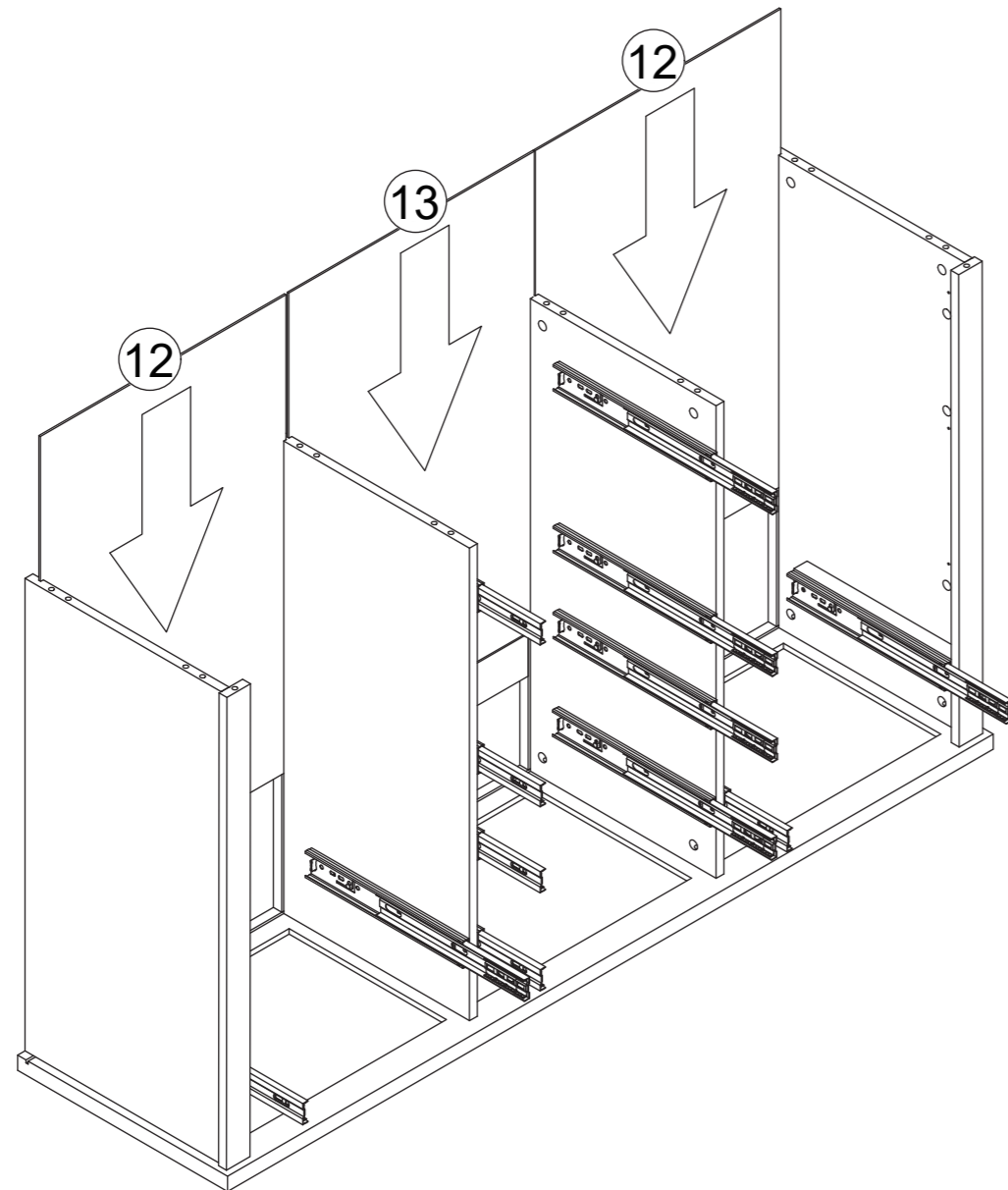

16

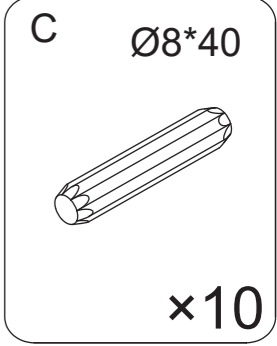
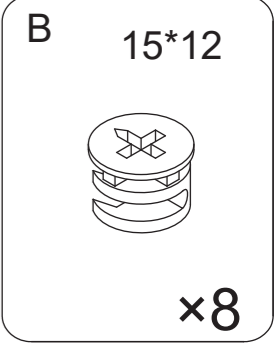
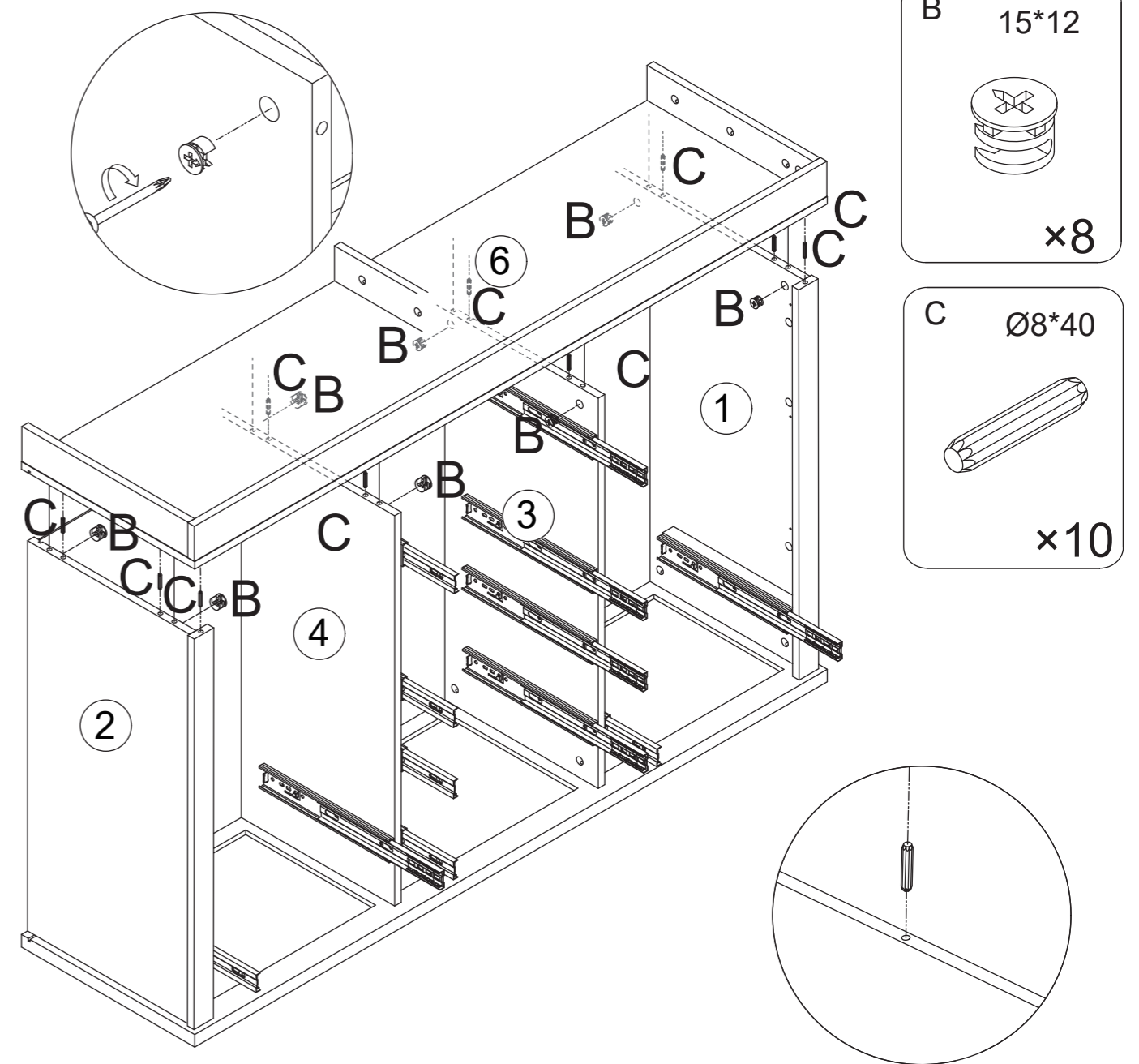

17

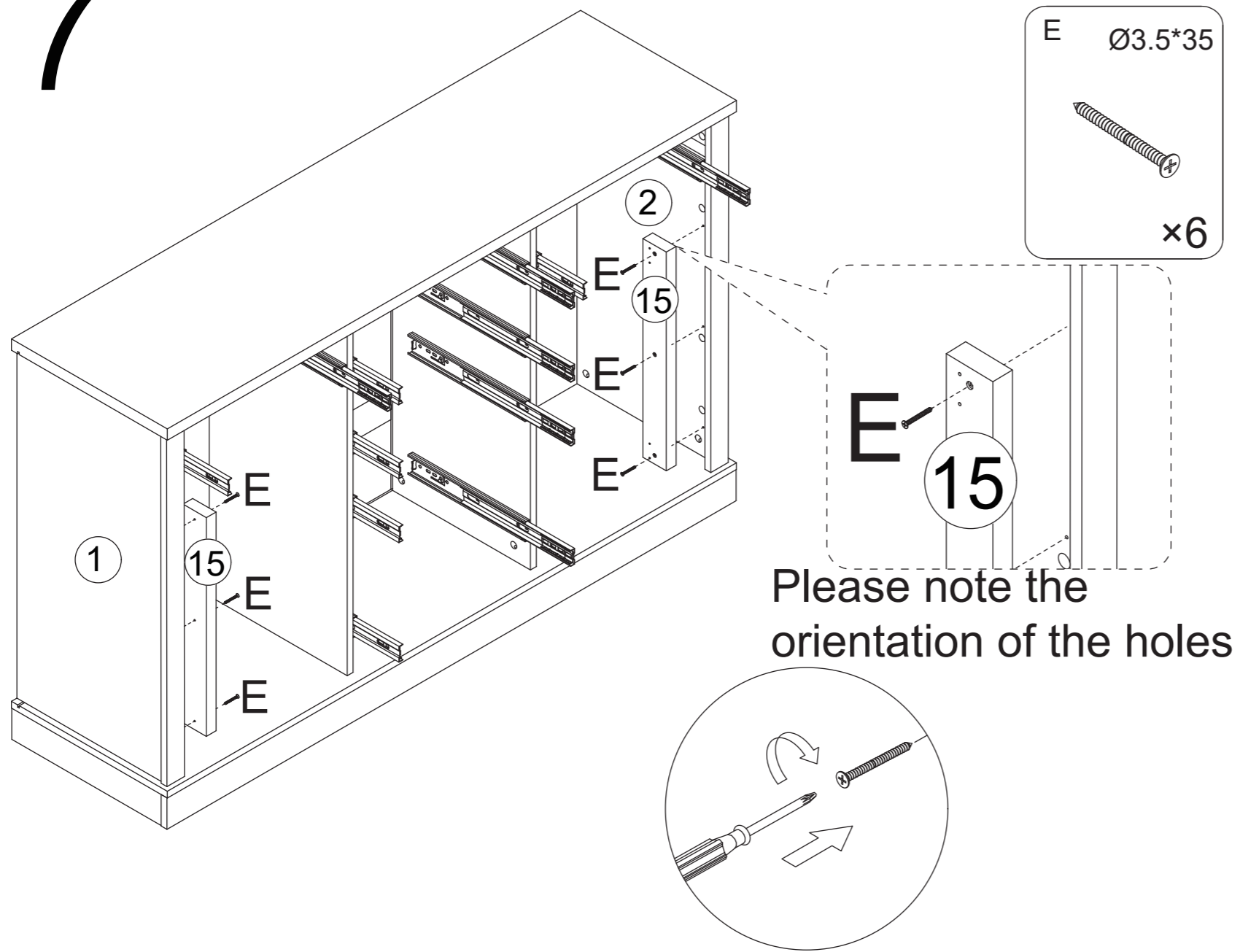

18

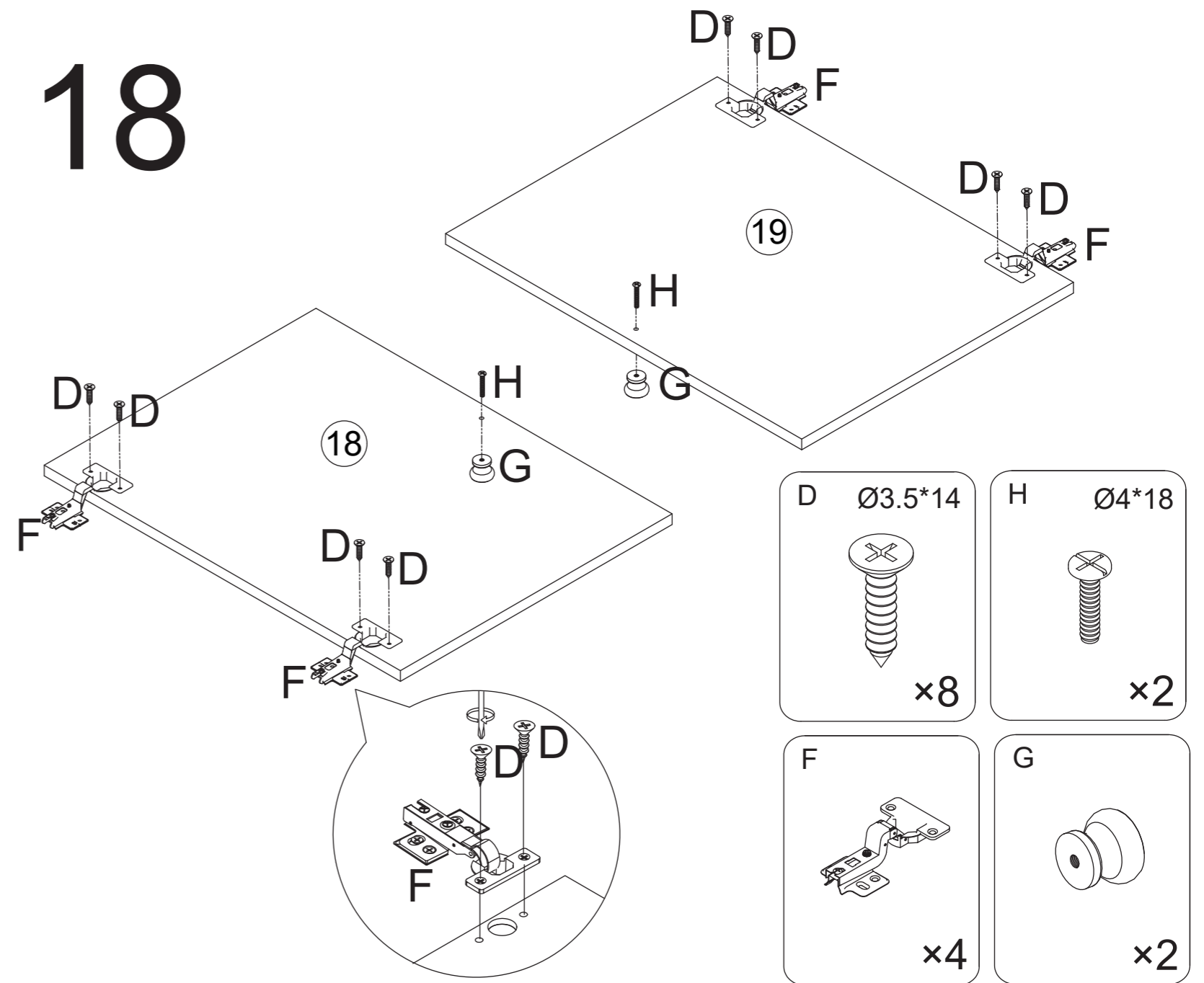

19

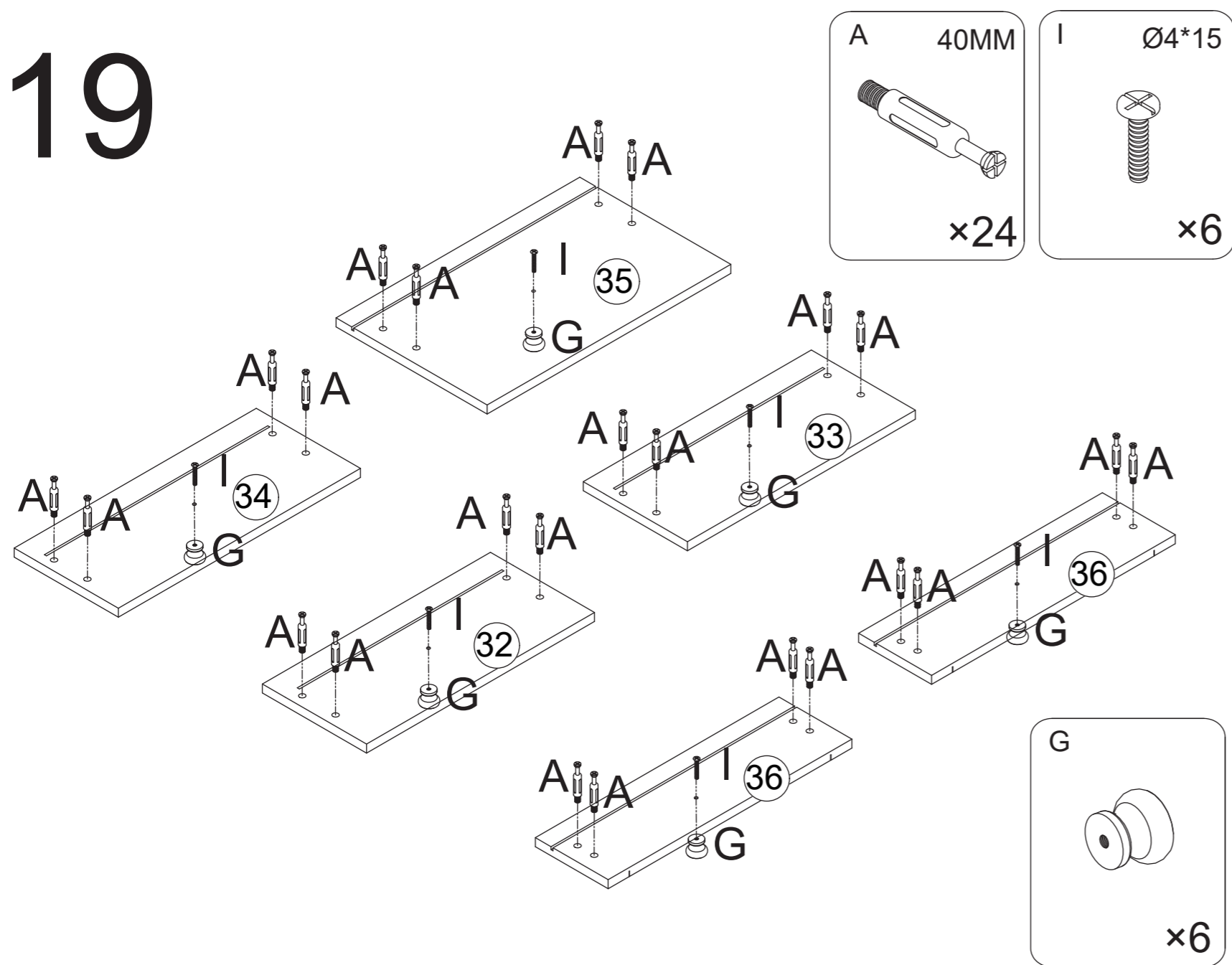

20

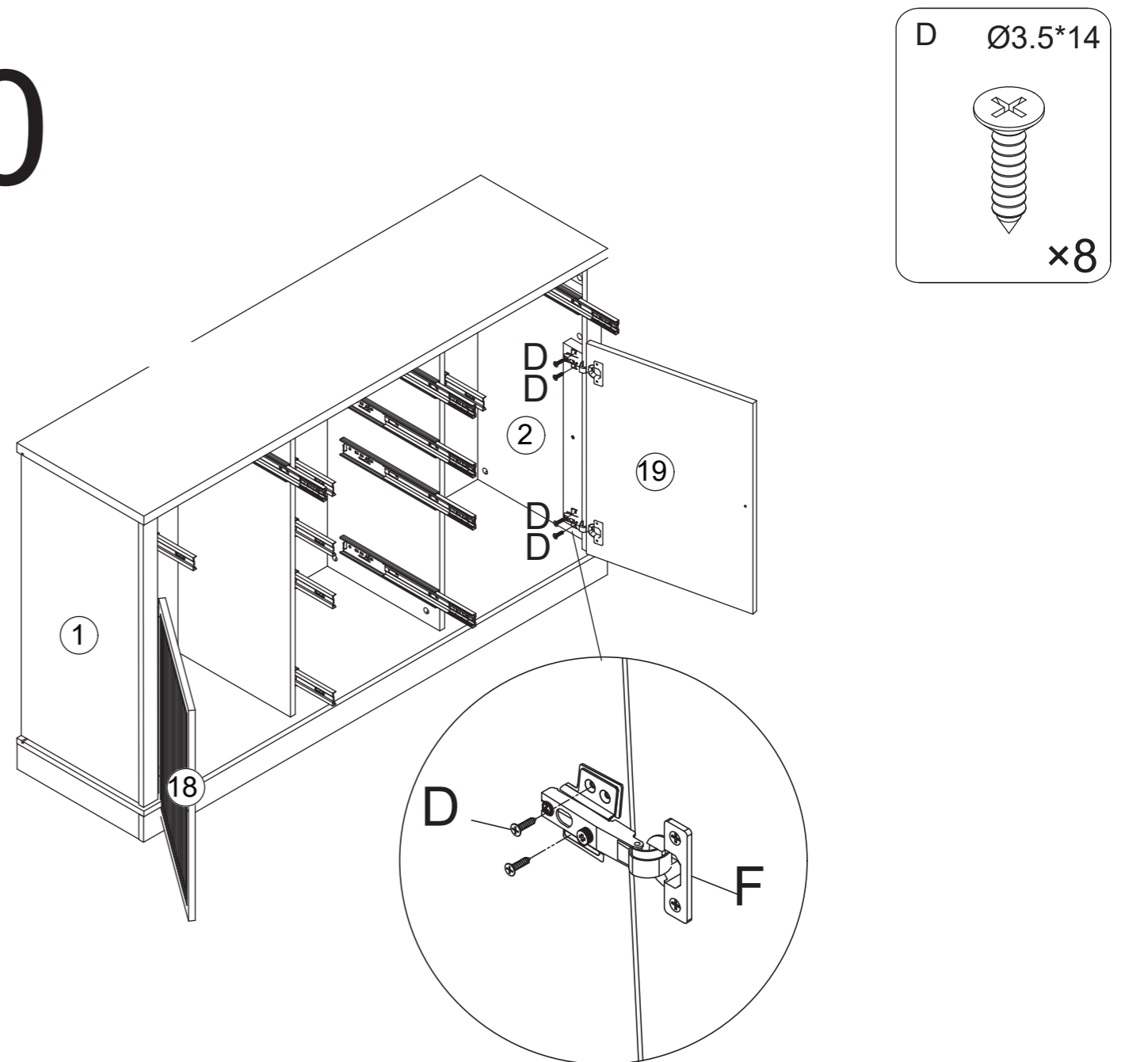

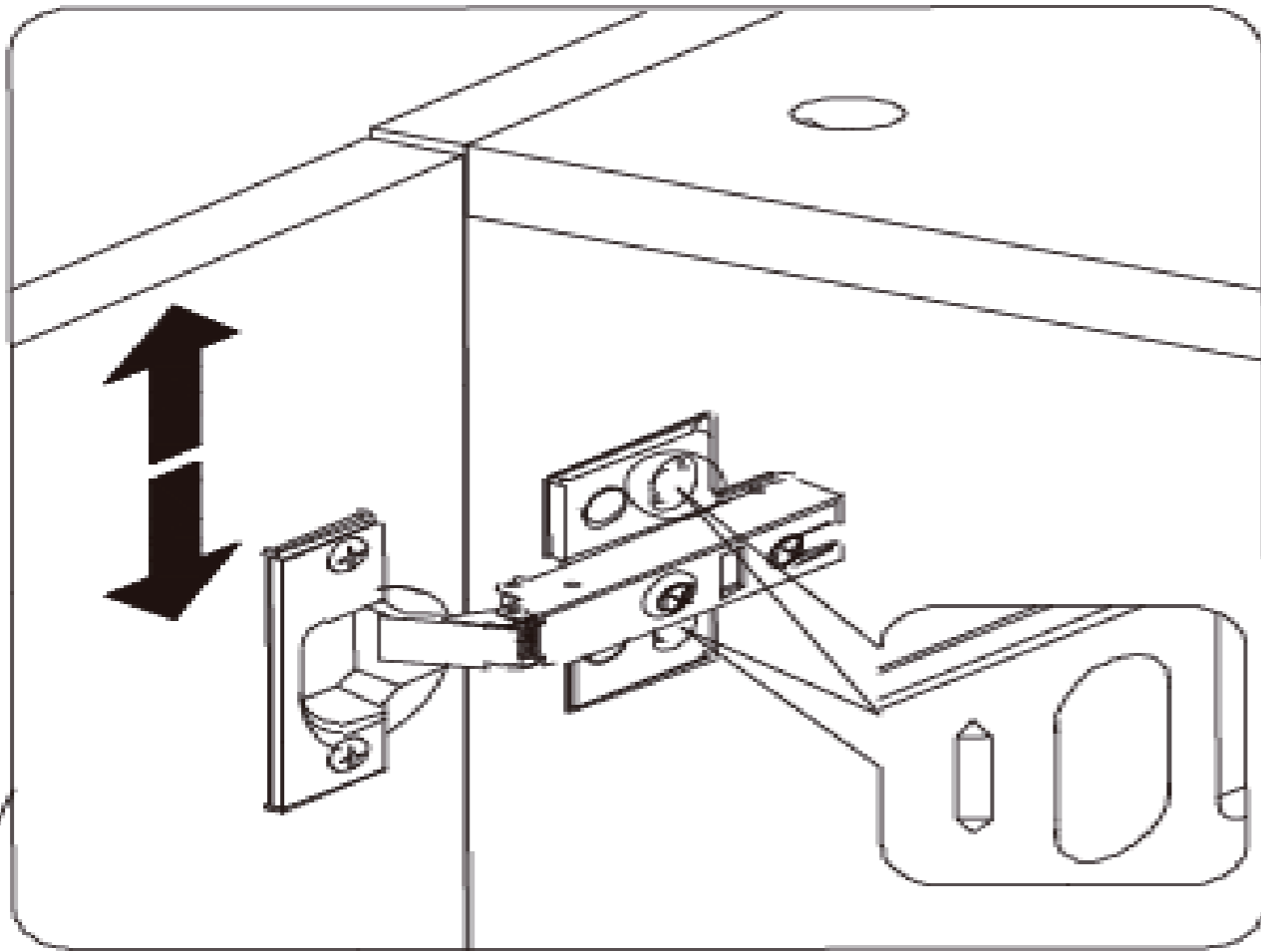

Up and down adjustment position

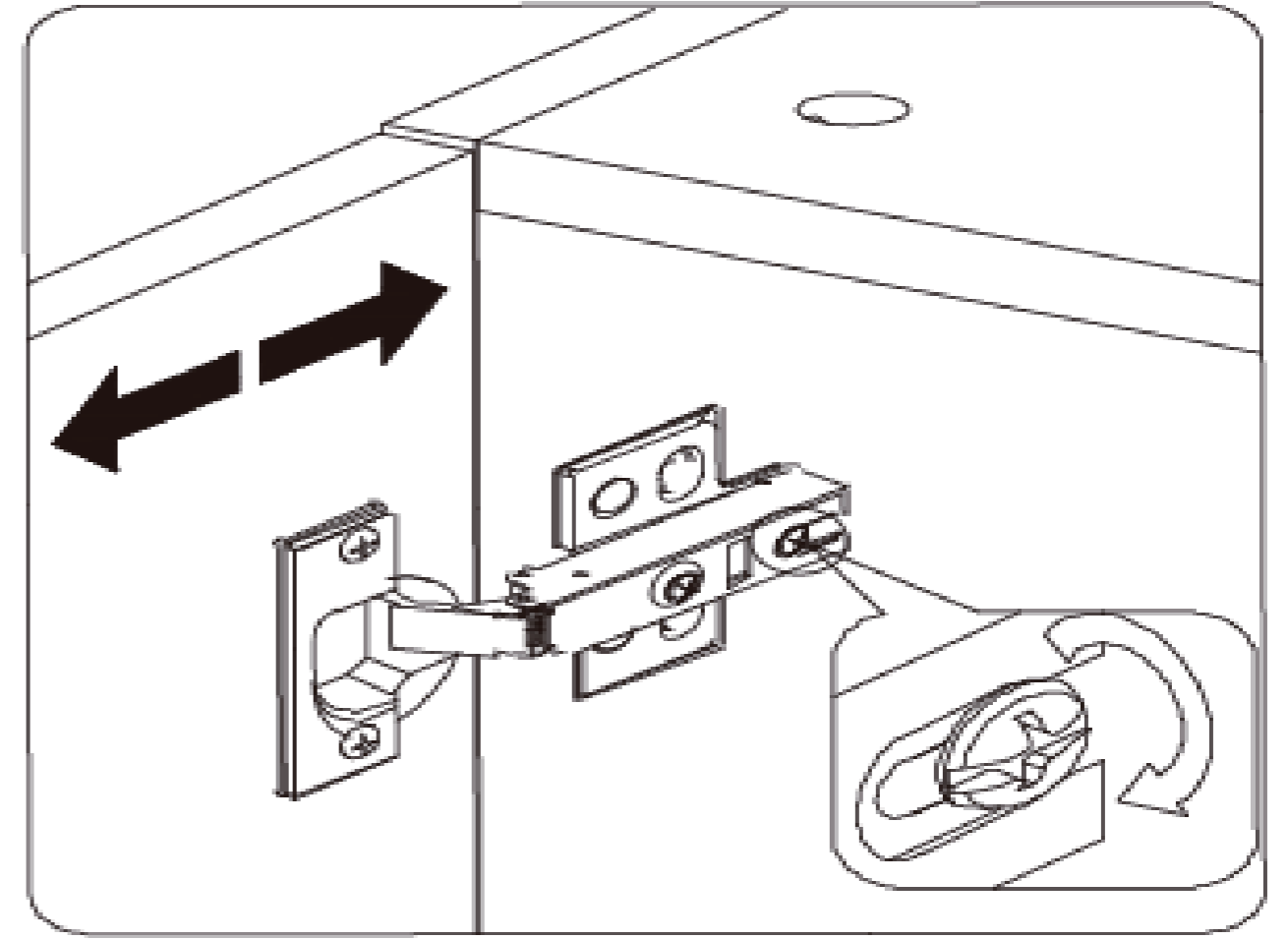

Front and rear adjustment position

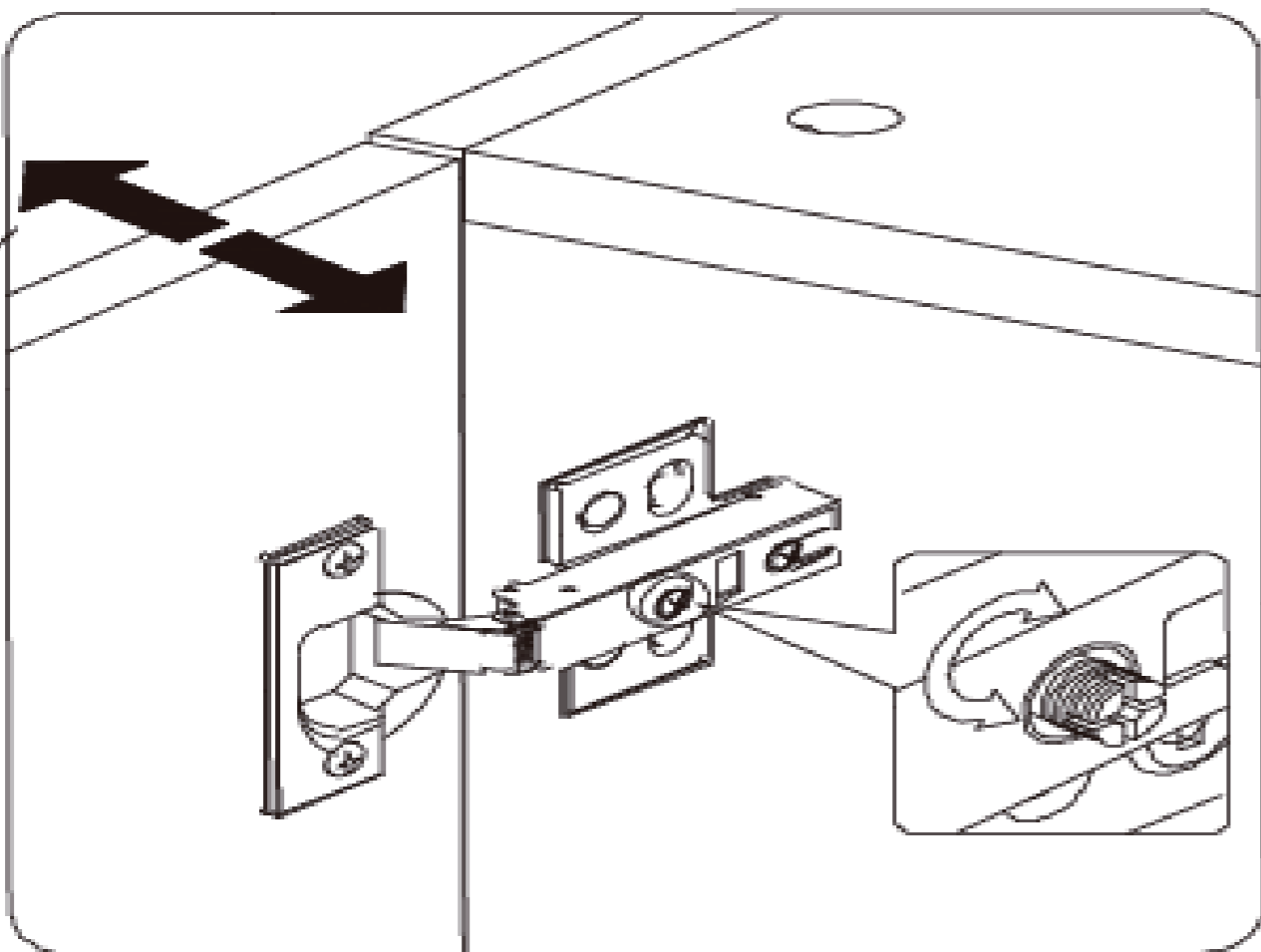

Left and right adjustable position

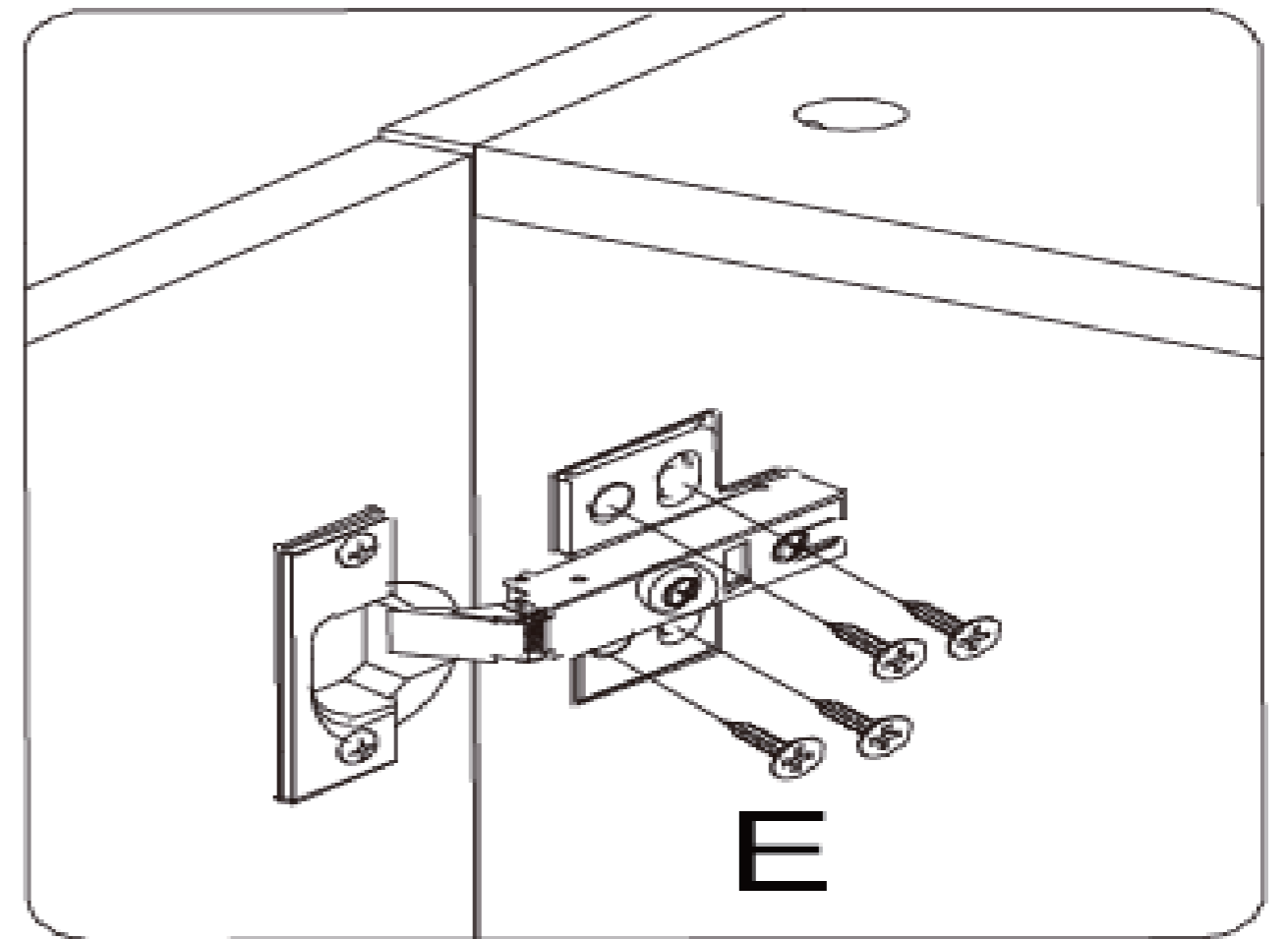

E

21

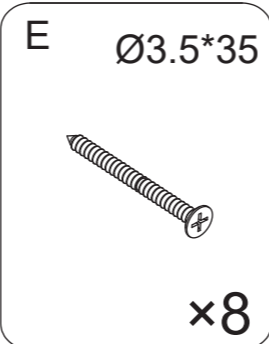
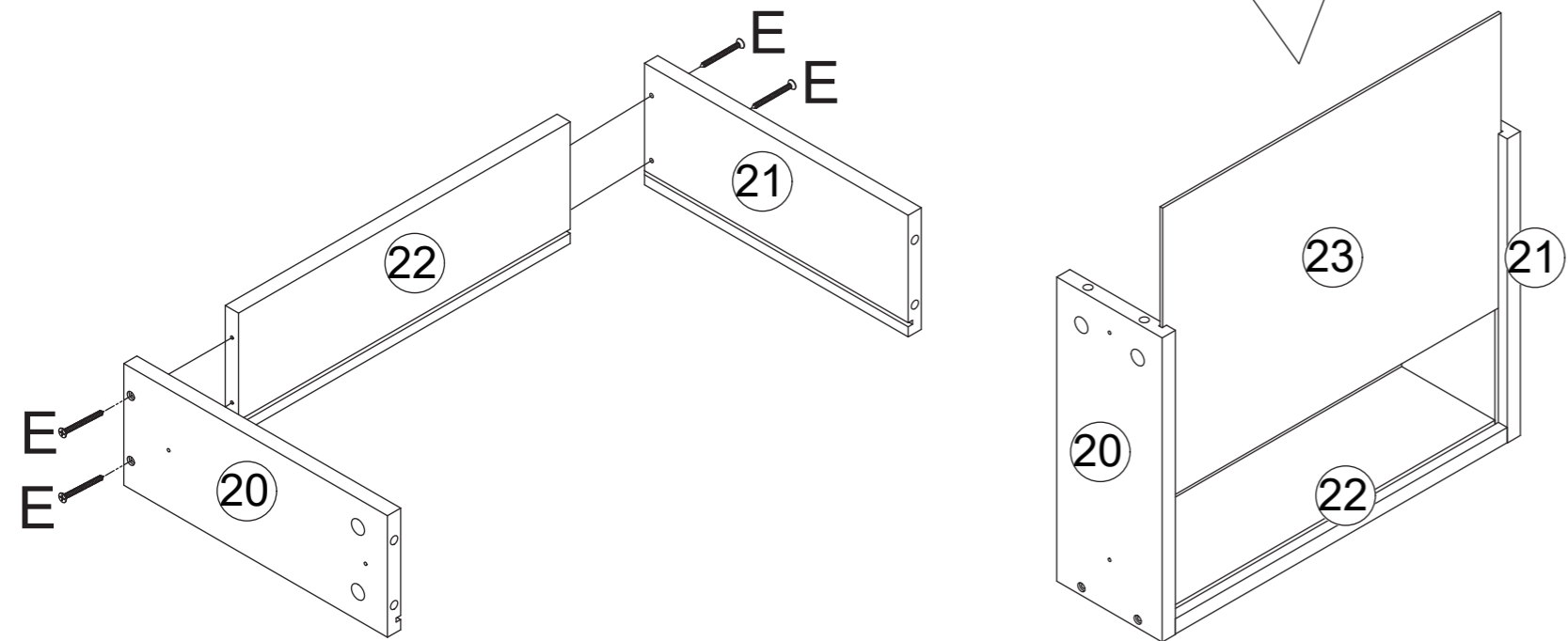

x2

22

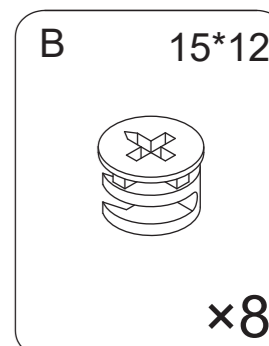
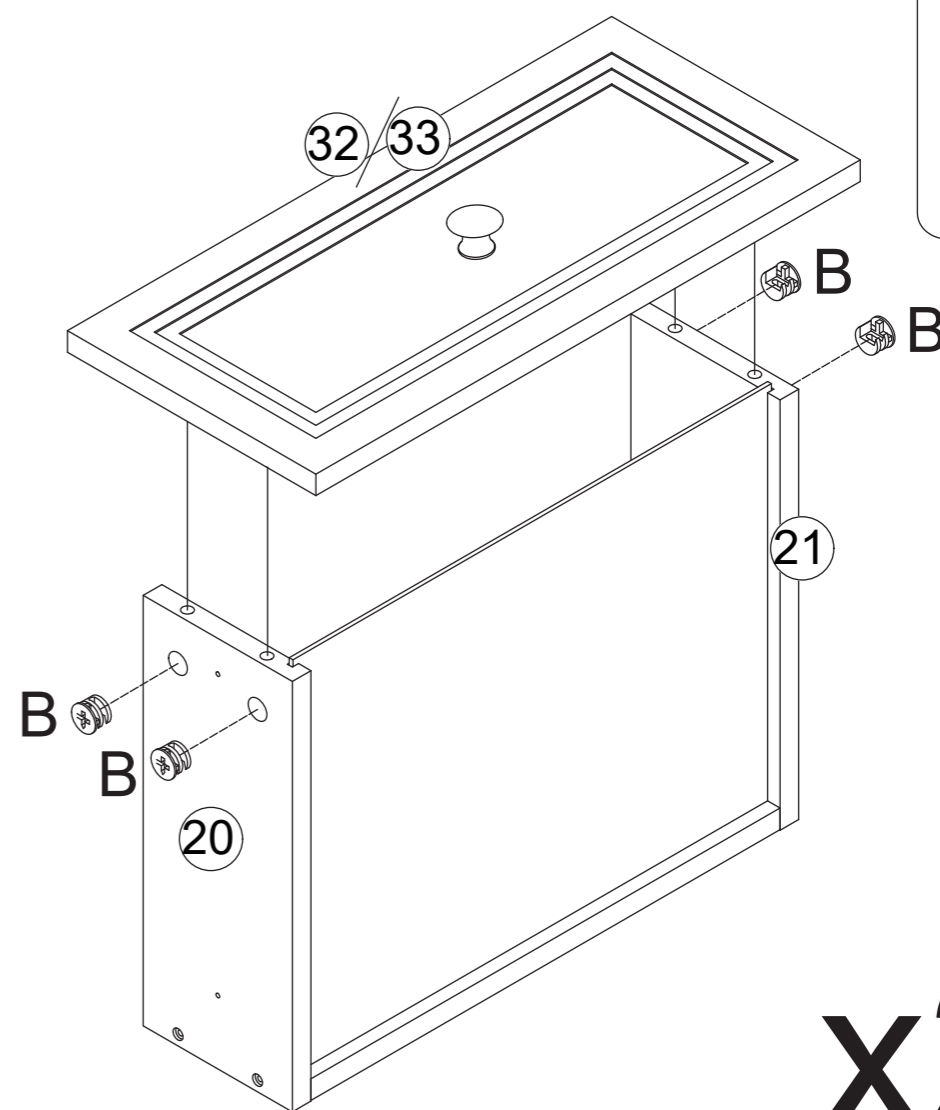

x2

23

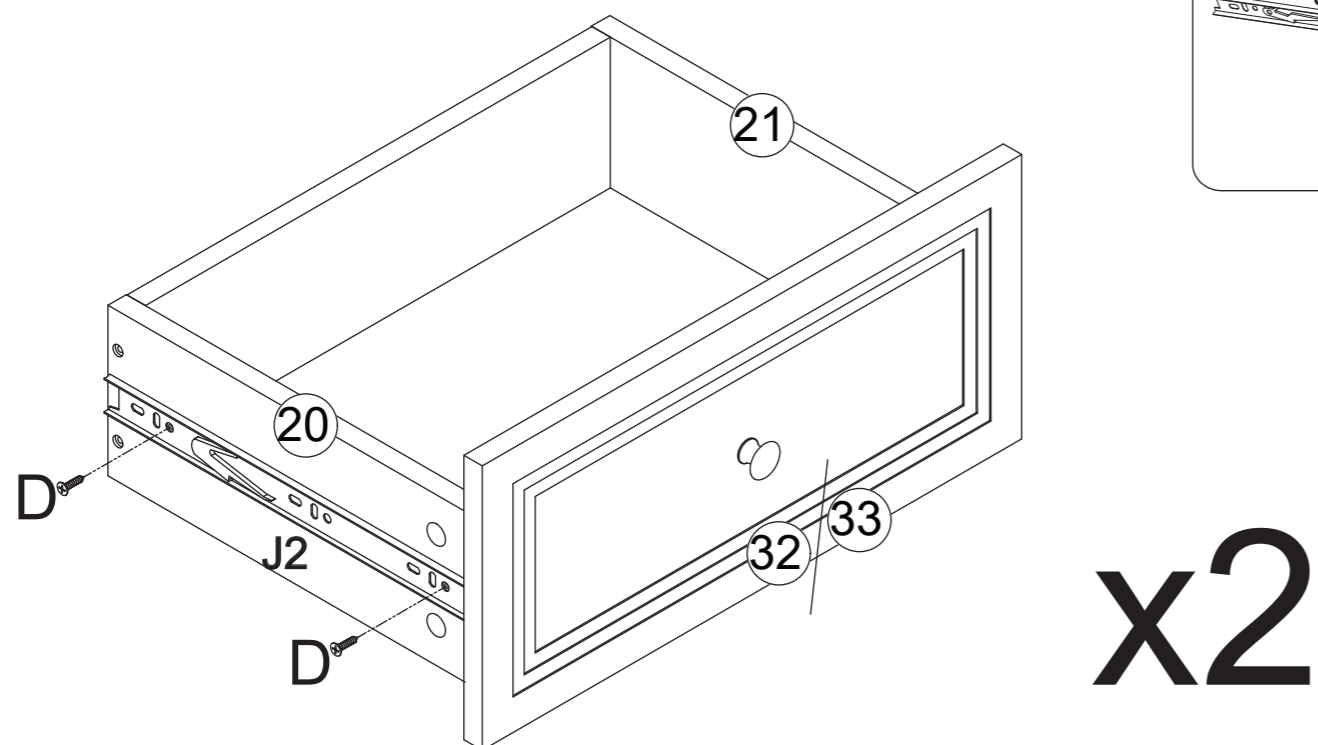
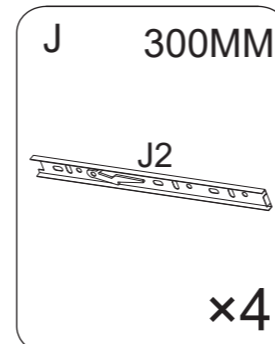
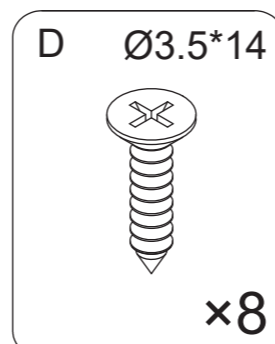
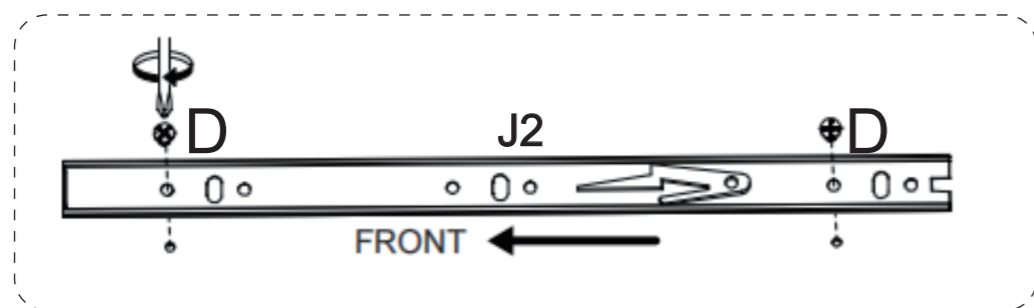

x2

24

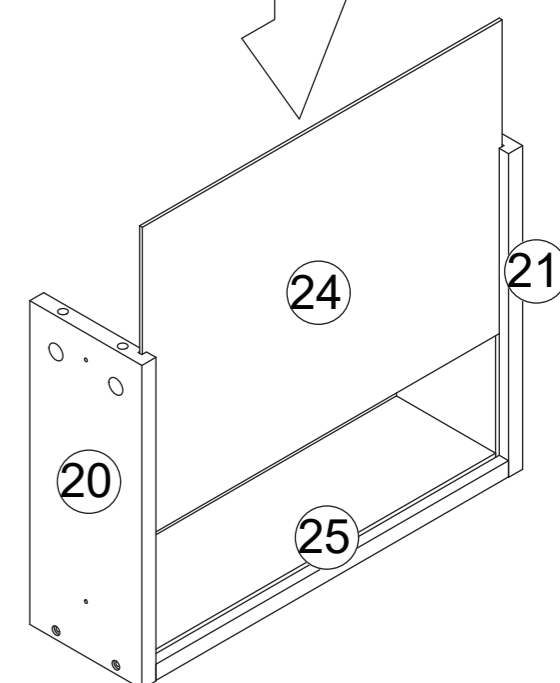
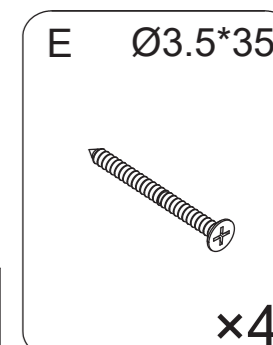
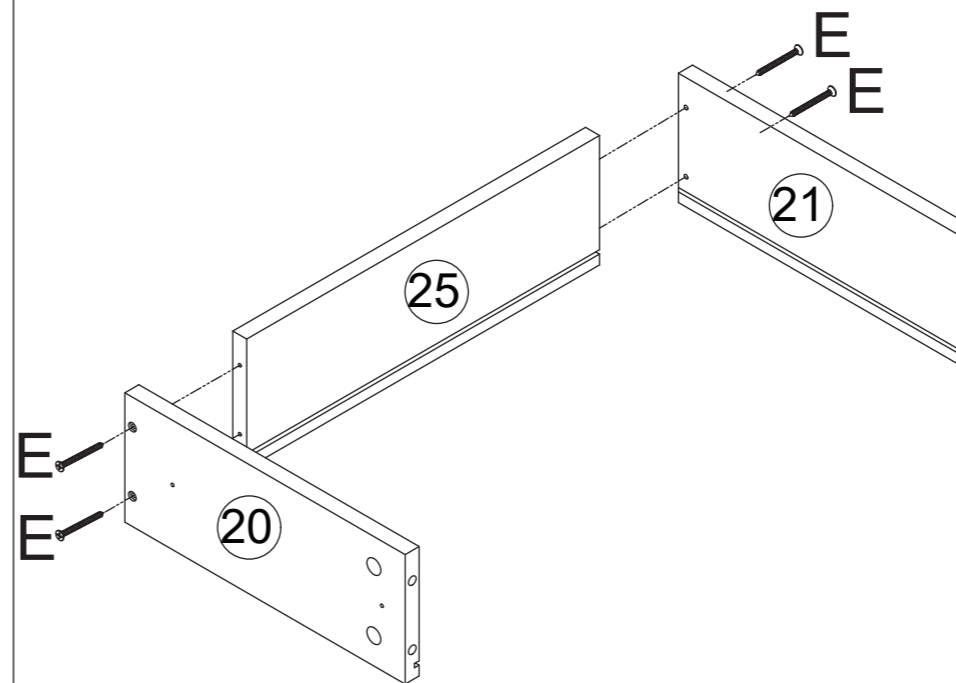

25

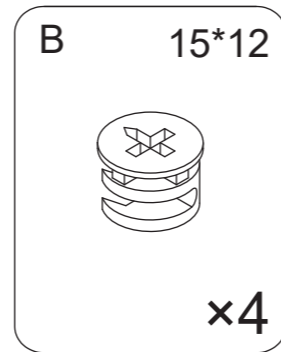
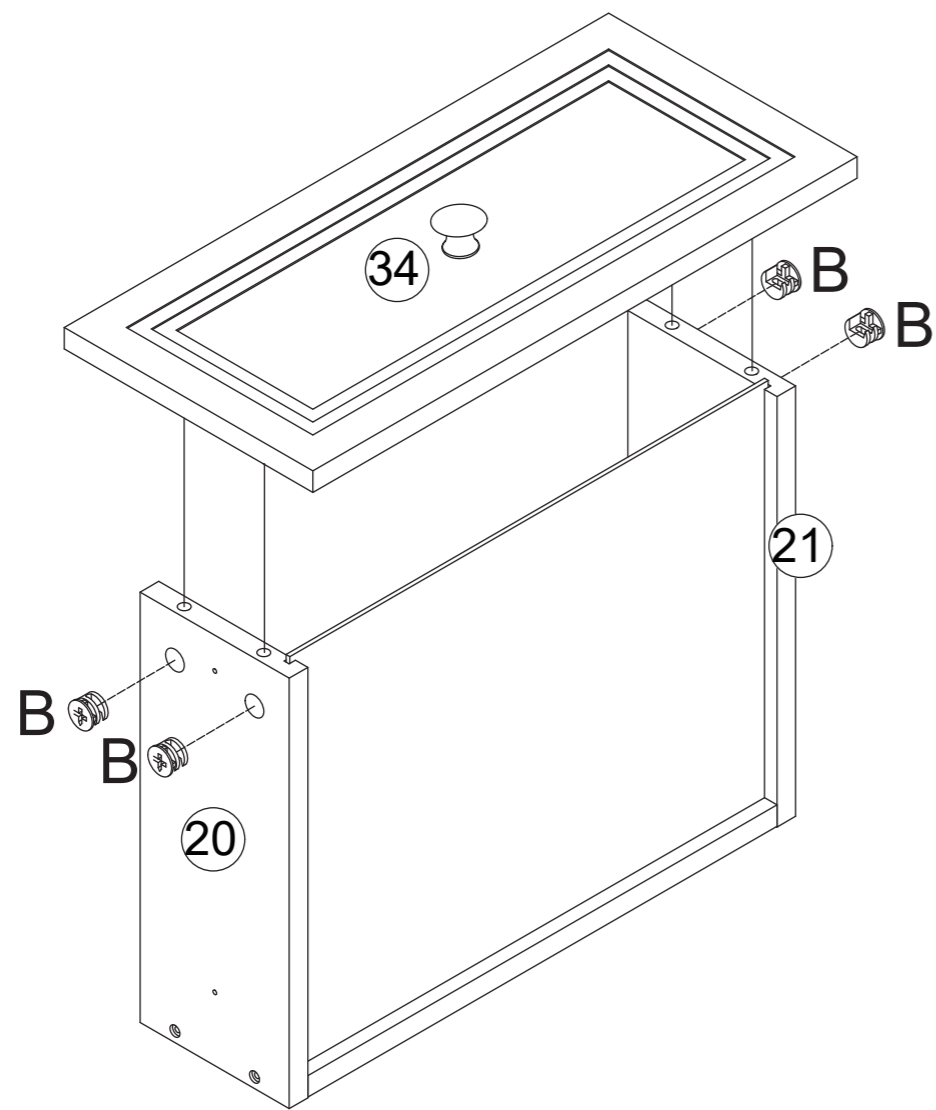

26

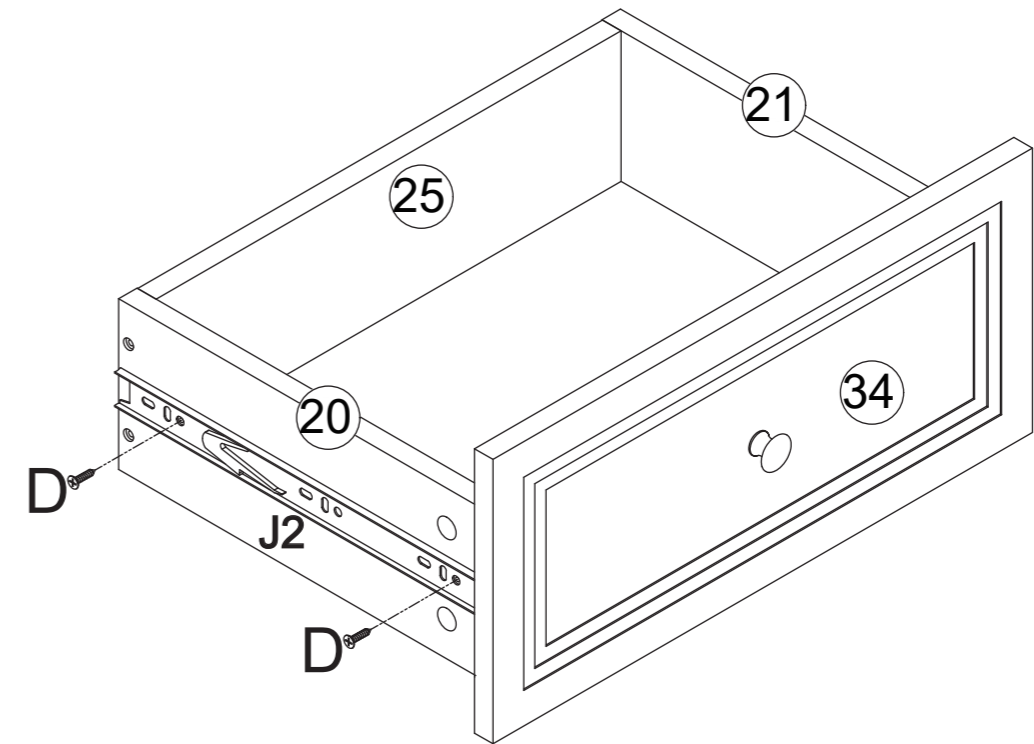
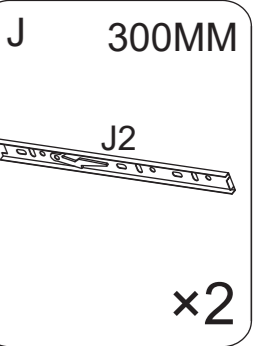
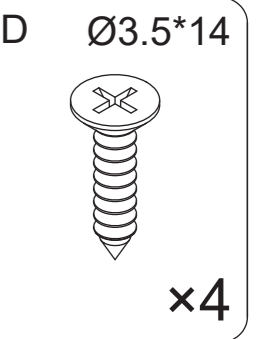
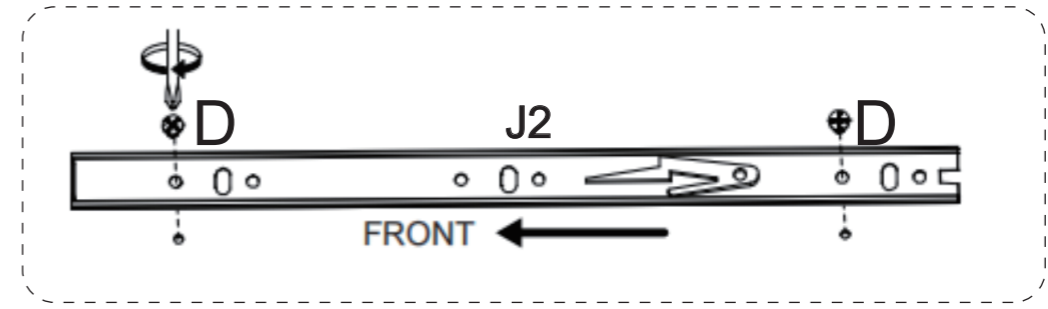

27

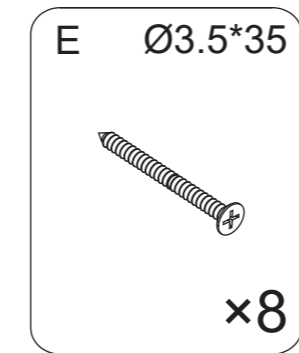
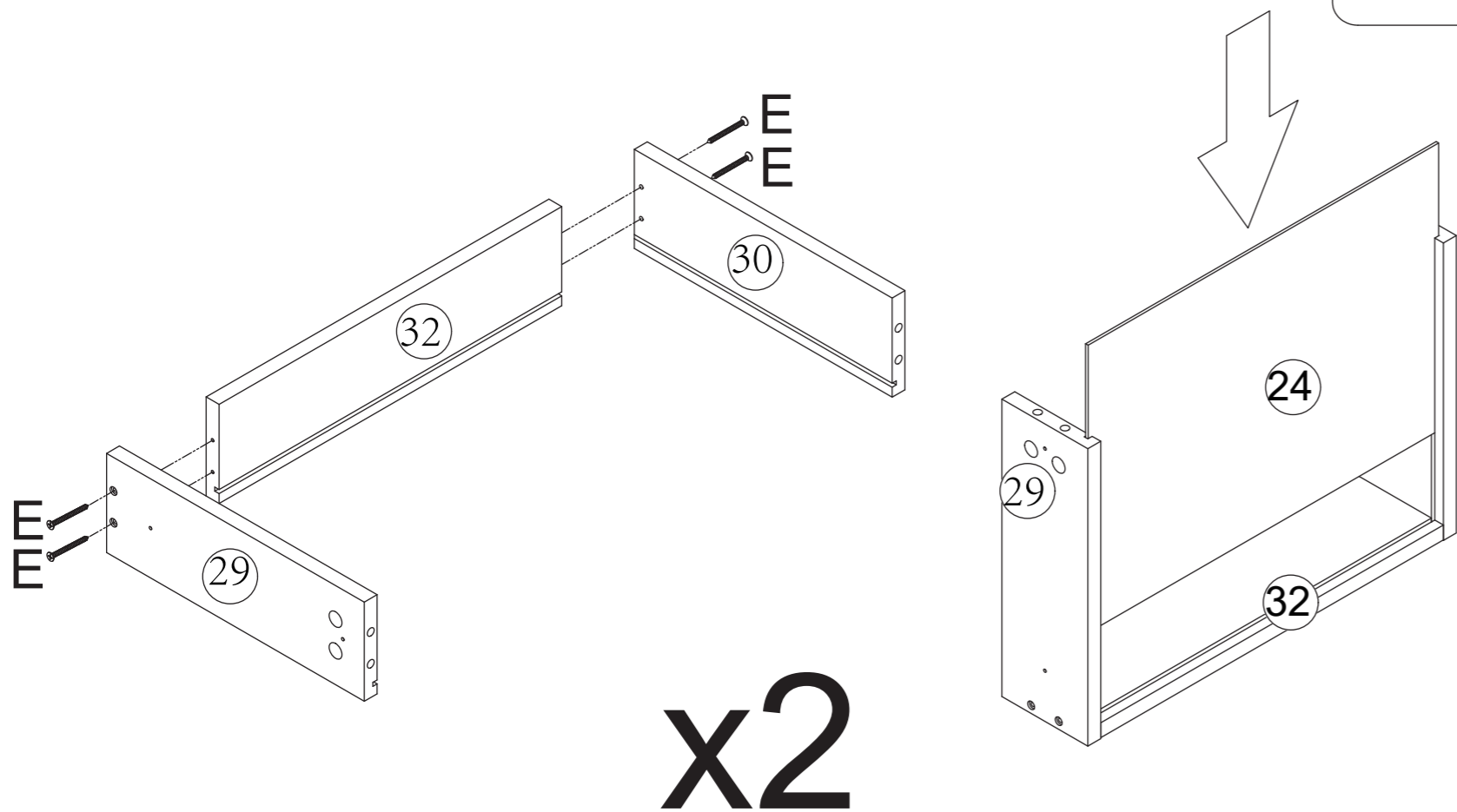

x2

28

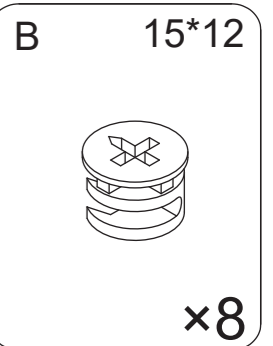
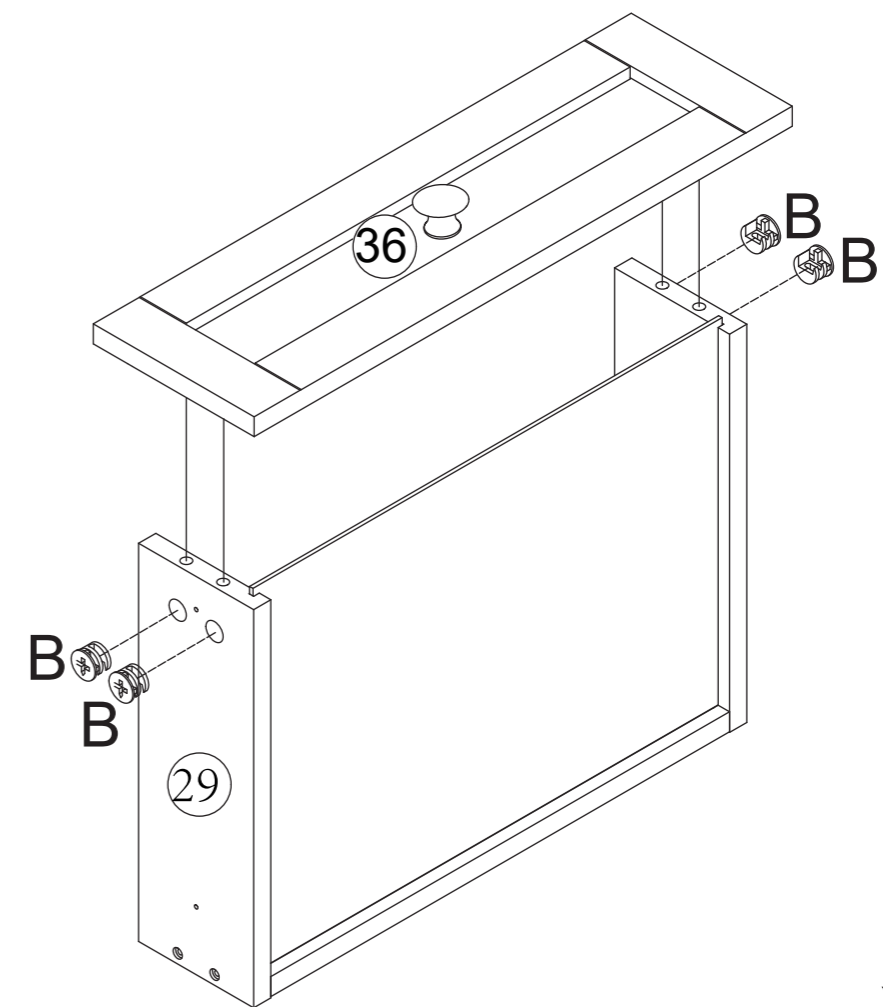

x2

29

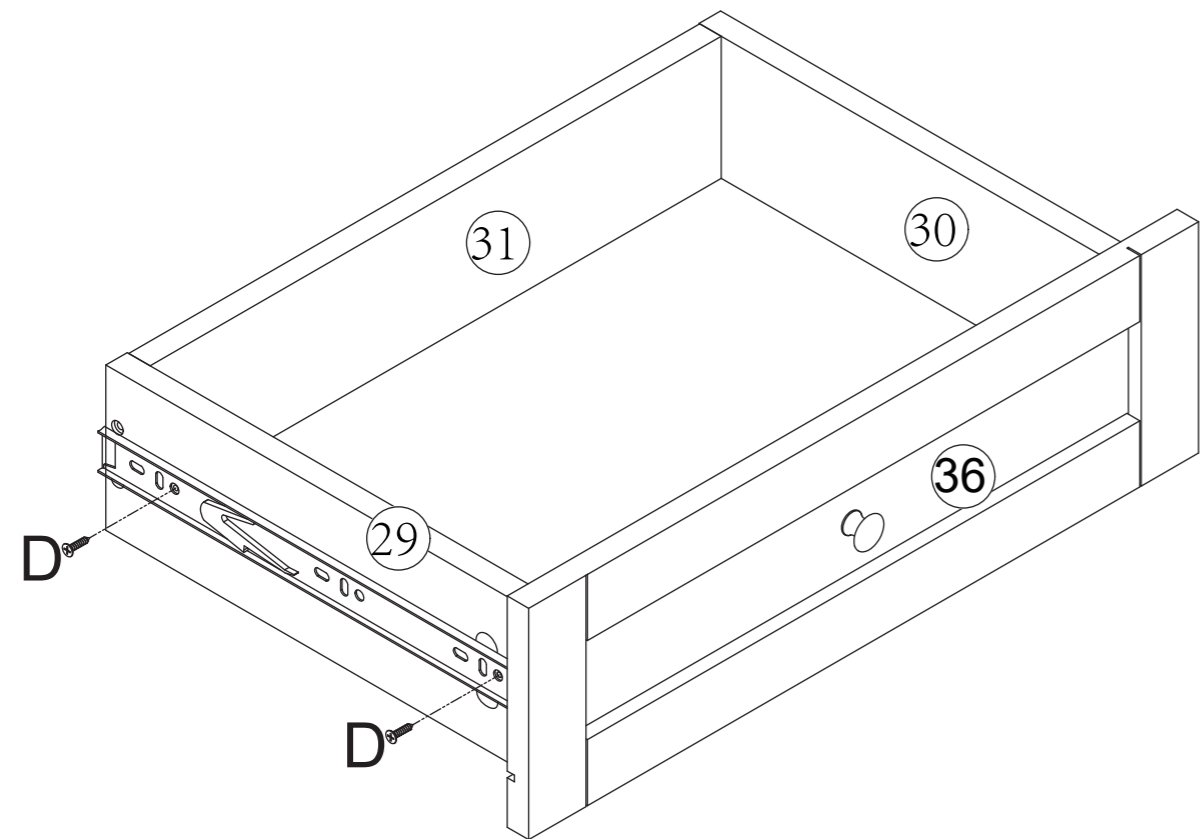
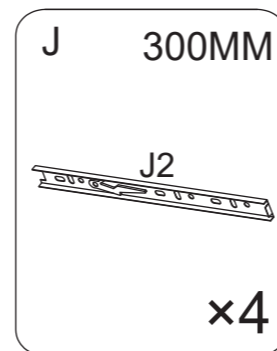
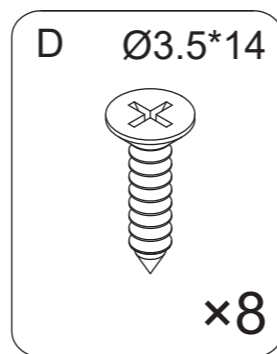
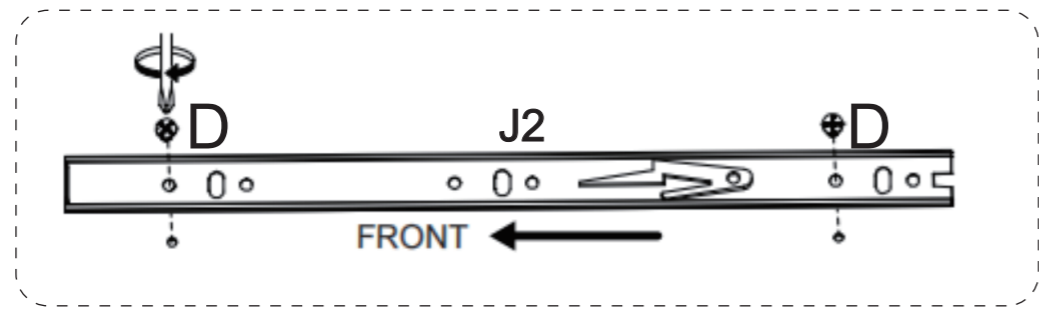

x2

30

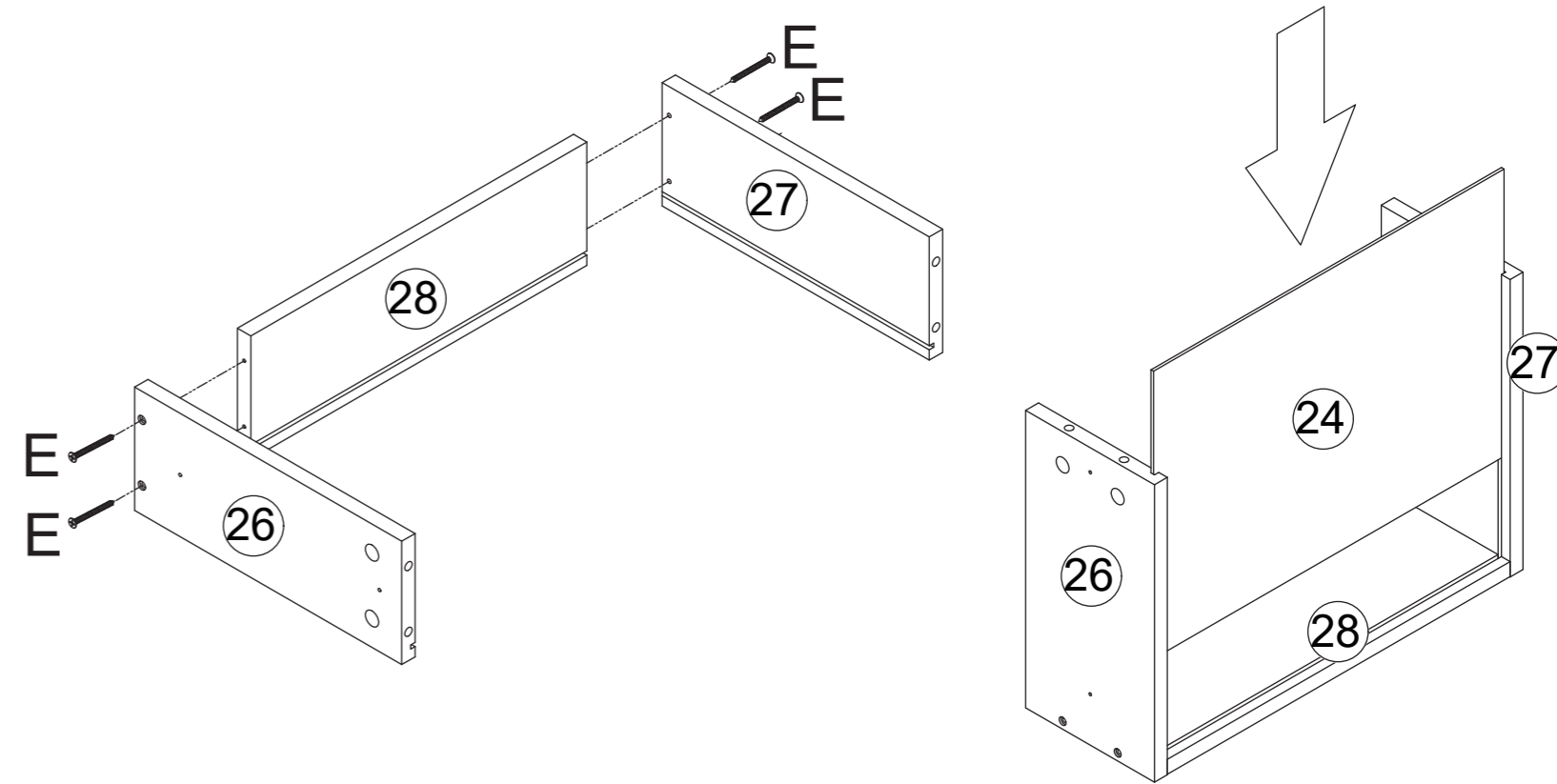
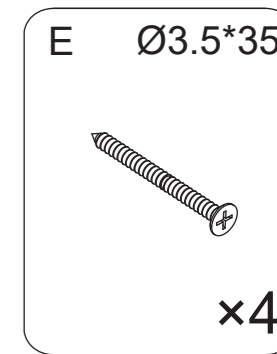

31

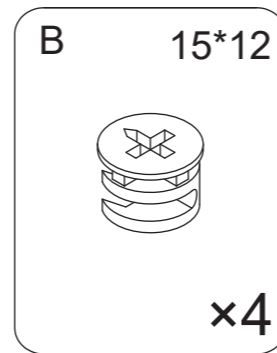
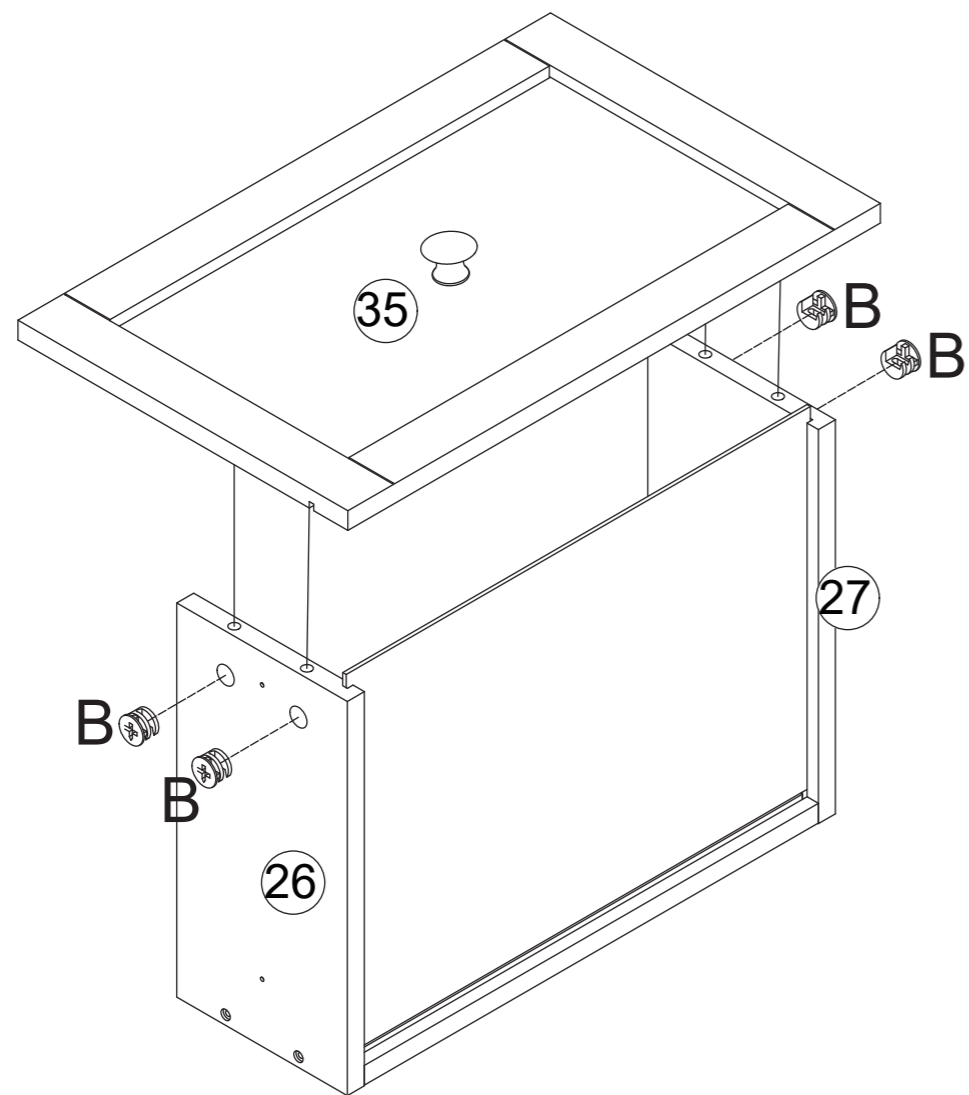

32

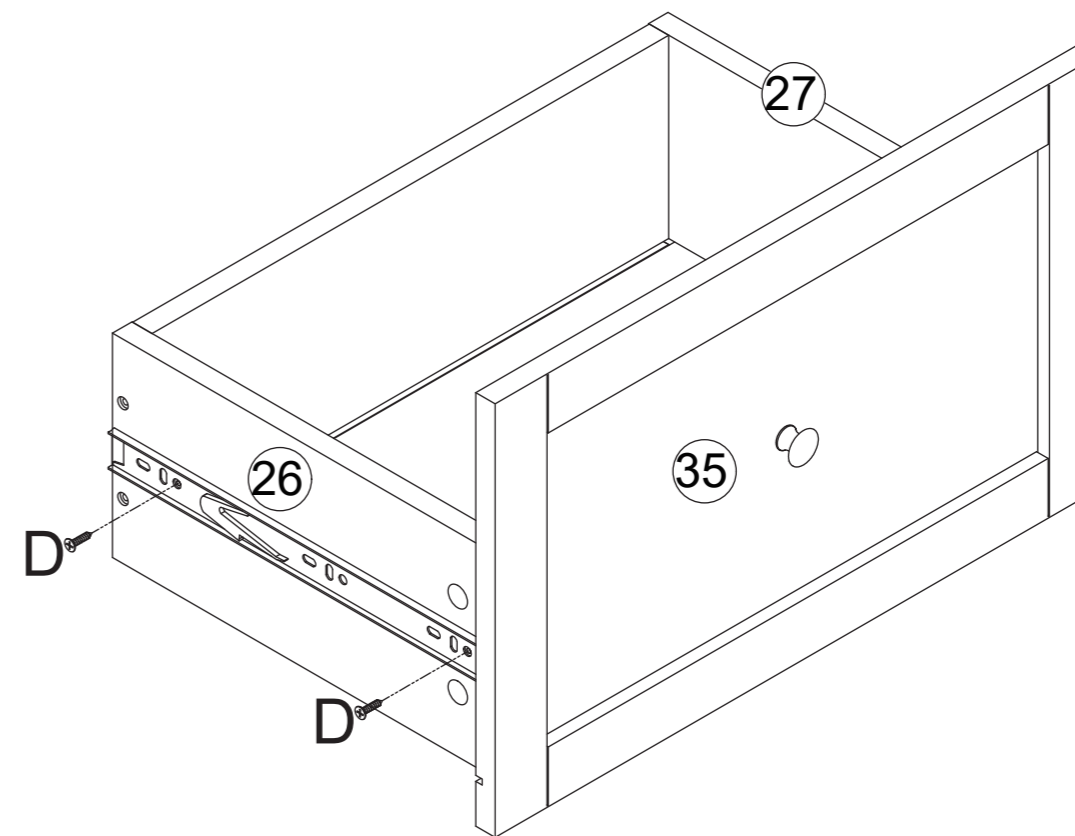
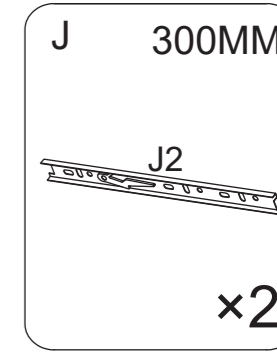
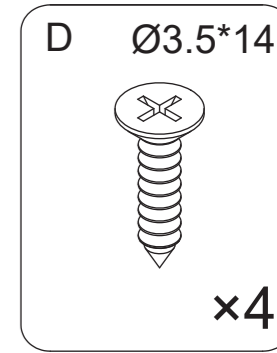
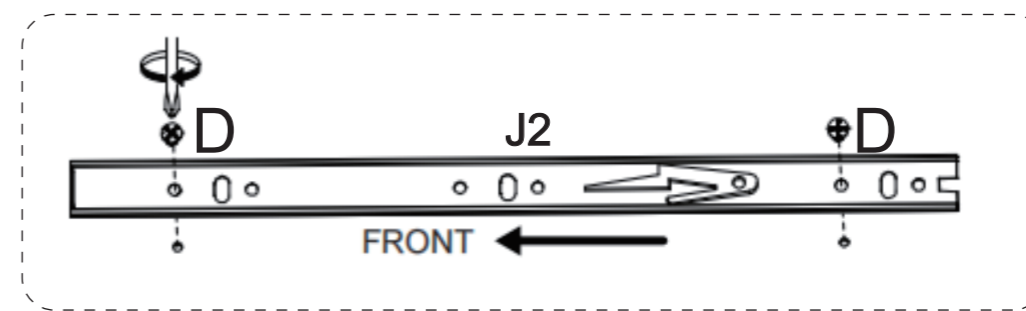

33



REMARK:
Simply push the ball bearing cart all the way to the end of the slide(in both sides), and align the slide runners on the drawer with the unit and push it carefully inside until it stops.

NOTE:
If the drawer does not go in smoothly, please take it out and repeat the step.

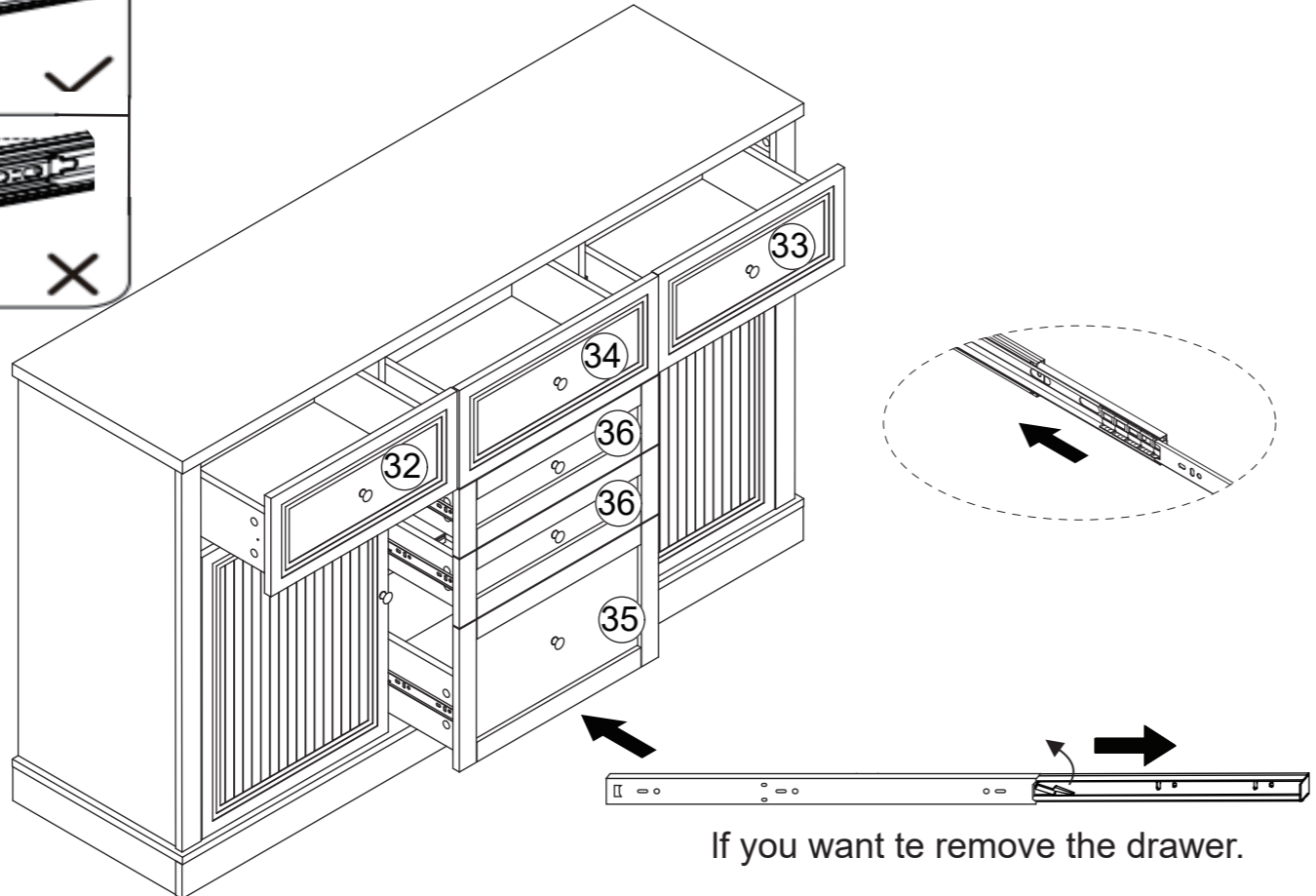
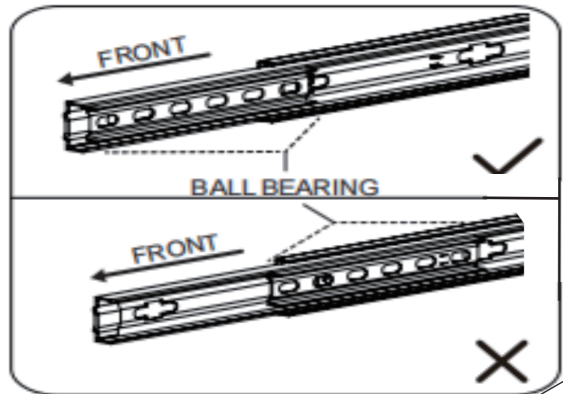

If you want to remove the drawer.

Please put the corresponding numbered drawer into the corresponding position.

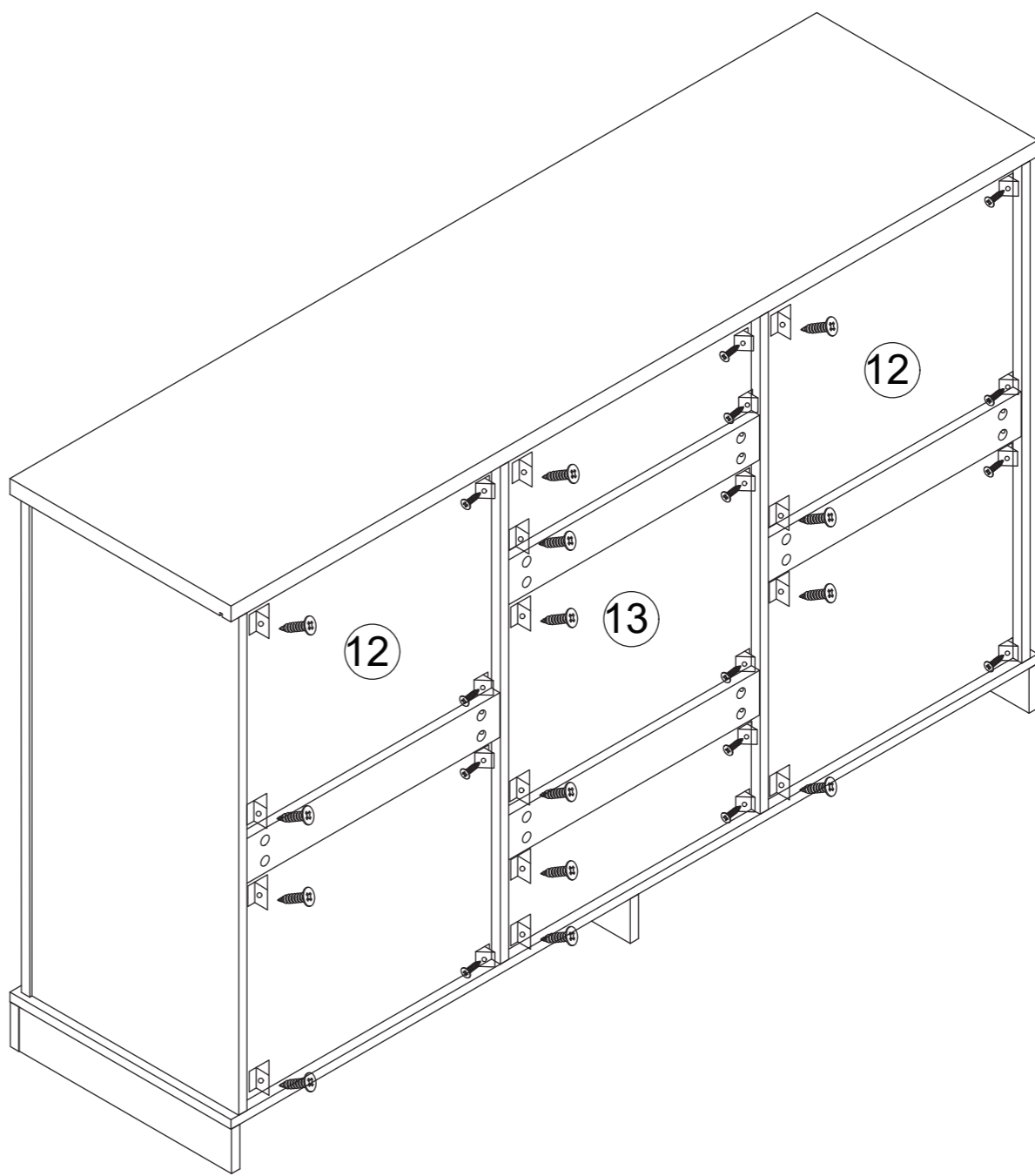

Kx28
Lx28

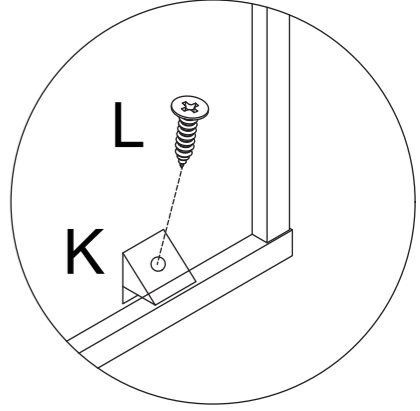
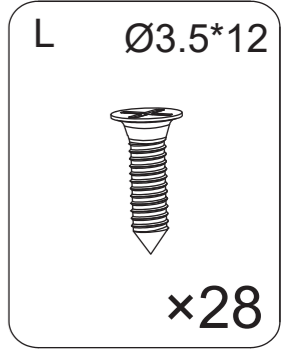
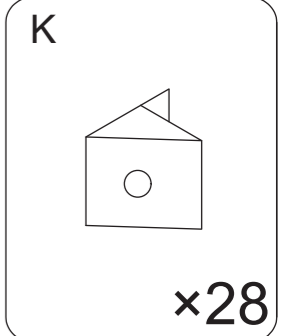

34

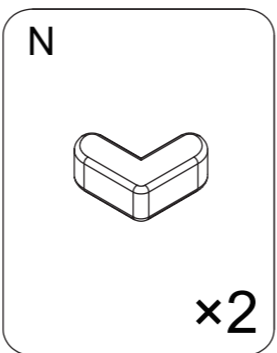
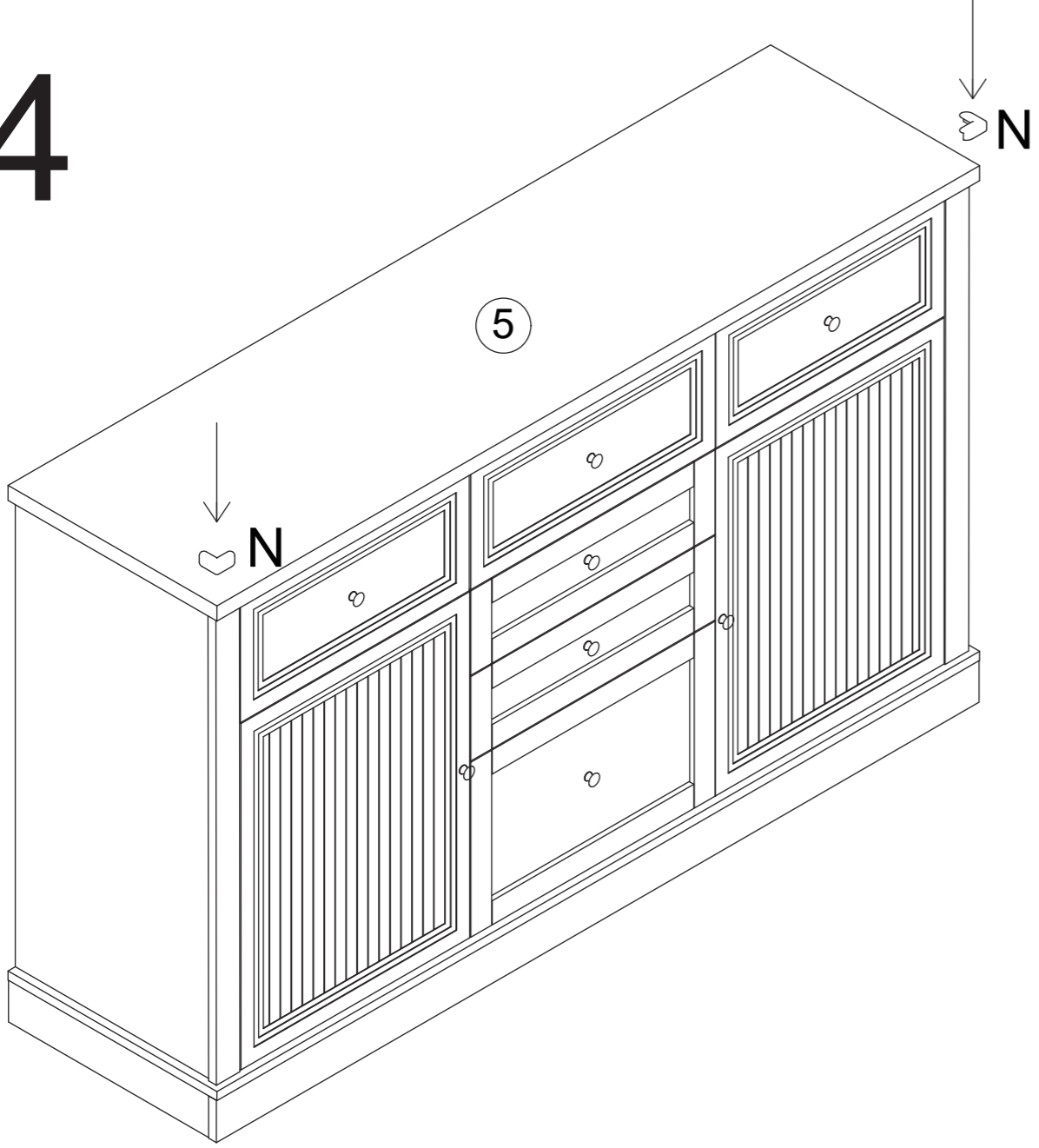

35

