

# INSTALLATION AND CARE GUIDE

## BEFORE YOU BEGIN



Prior to installation, thoroughly read and comprehend this manual.



We recommend professional installation for optimal results.



Shield surfaces from sharp objects, high heat, and chemicals.



Verify all components against the **PART LIST**. Promptly inform your retailer of any missing items.

# TABLE OF CONTENTS

|                                      |       |
|--------------------------------------|-------|
| Specifications .....                 | 4     |
| What's included in the package ..... | 5     |
| Installation Instruction .....       | 6-9   |
| Care and Maintenance .....           | 10-11 |
| Warranty .....                       | 12-13 |
| Replacement Part List .....          | 14-15 |

# SPECIFICATIONS

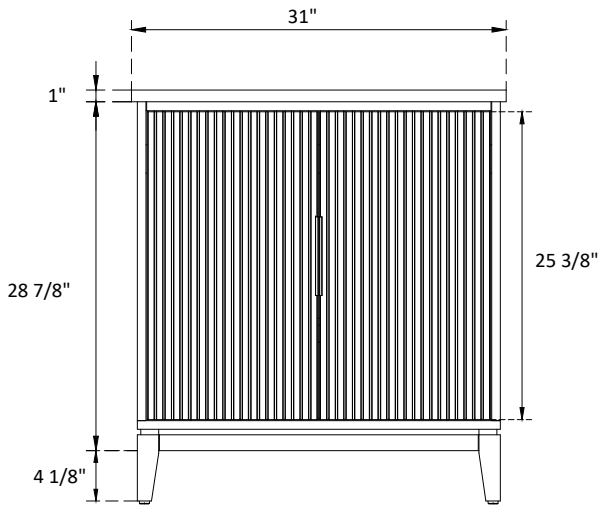
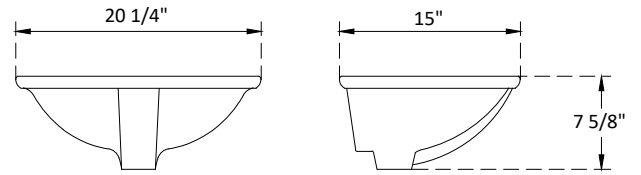
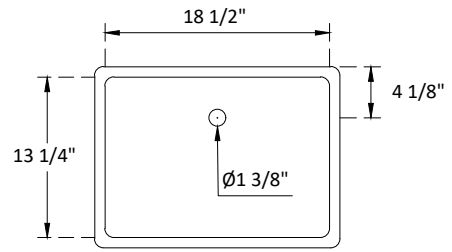
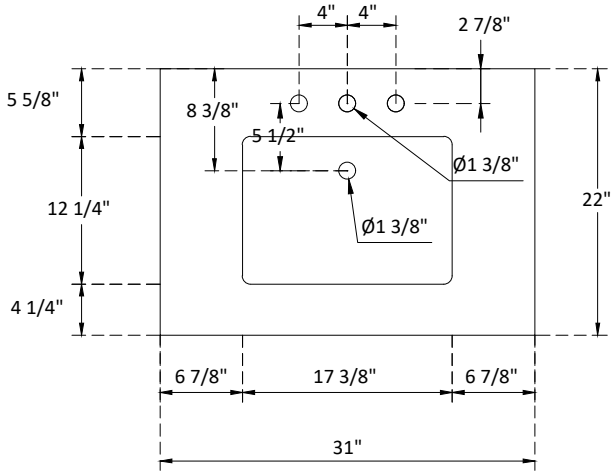

Handle:  
Overall length : 6 1/2"(165mm)  
center to center : 2 7/8"(72.5mm)

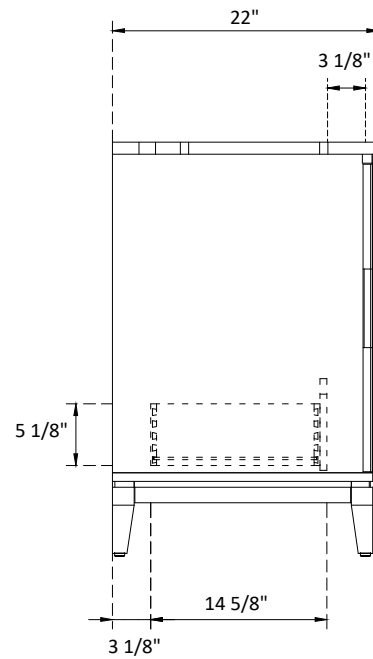
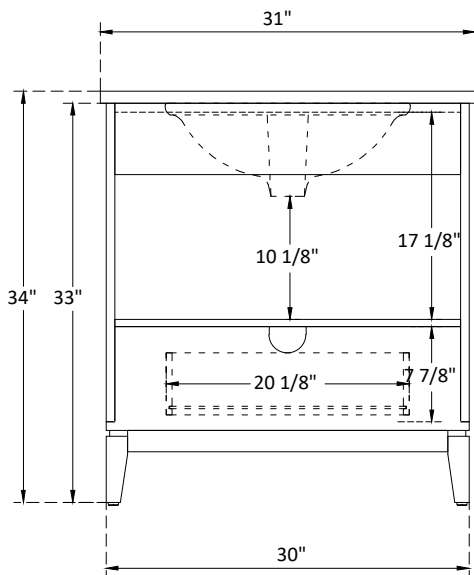
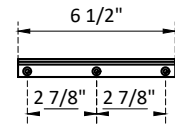

# WHAT'S INCLUDED IN THE PACKAGE

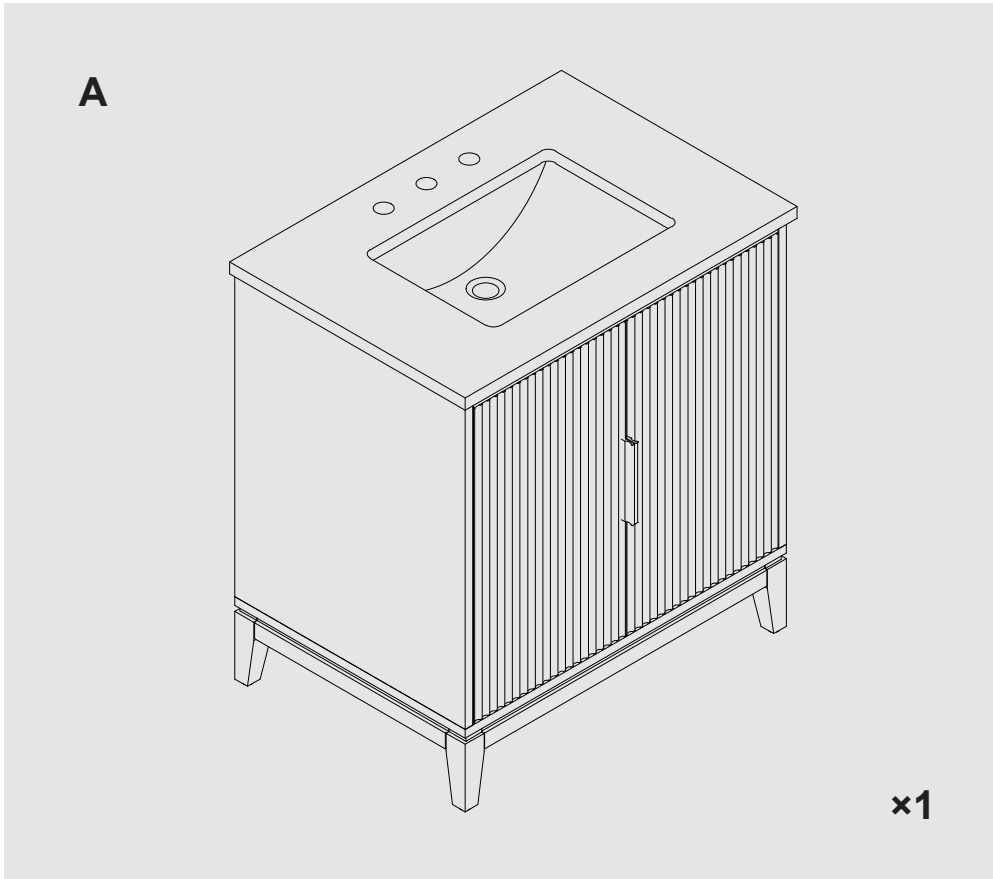

A. VANITY

# INSTALLATION INSTRUCTION

**STEP1.** Adjust the vanity's height at its final location.

**Note:**

Rotate the adjustable leveler foot pins, located on the bottom of each leg, to adjust the vanity's height.

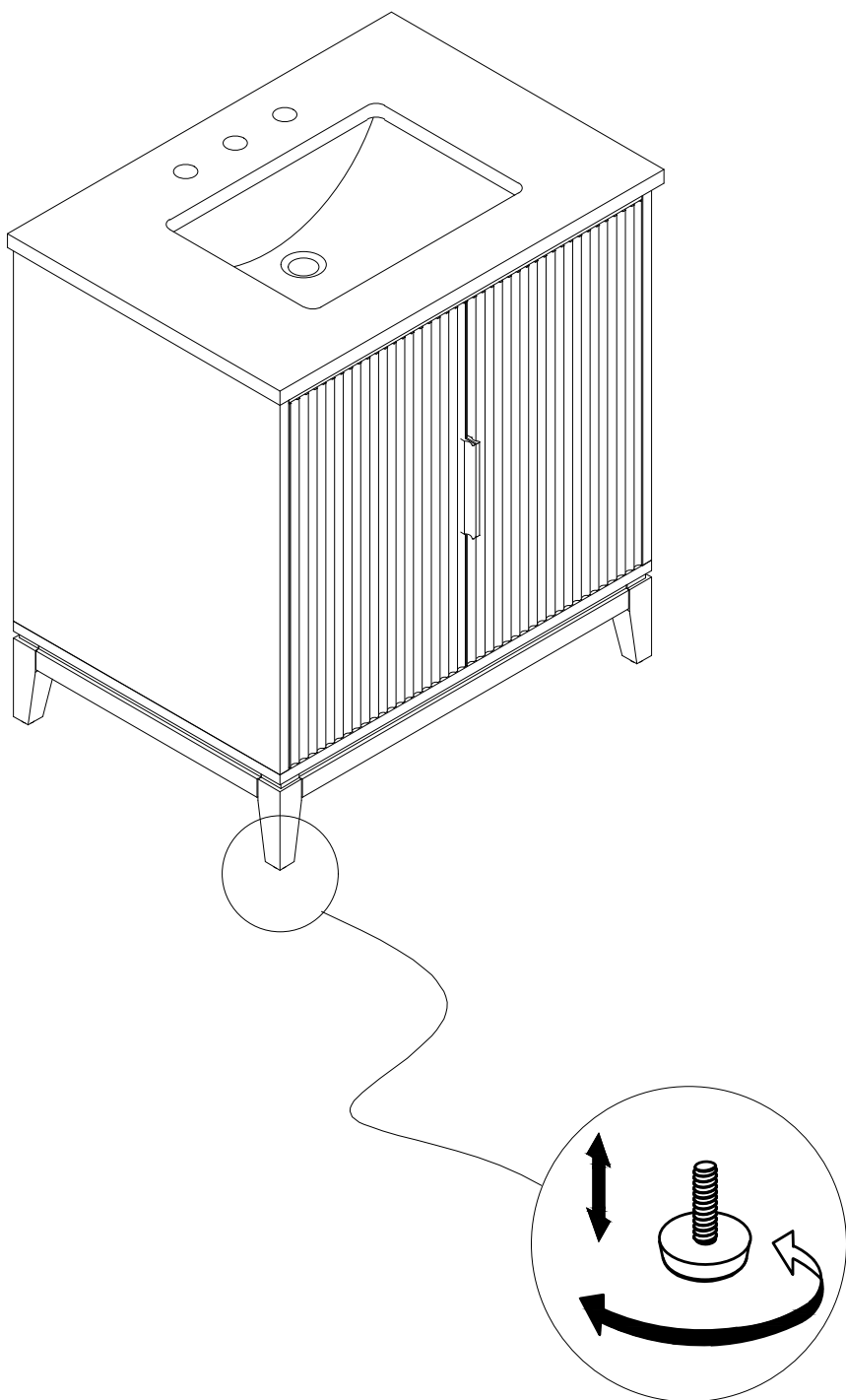

# INSTALLATION INSTRUCTION

**STEP2.** Mount the vanity to the wall (mounting hardware not included). Ensure the vanity is securely fastened using suitable hardware based on your wall type. Exercise caution to avoid disrupting any hidden electrical or water lines present within the wall.

**Note:**

It is crucial to securely fasten the vanity to the wall.

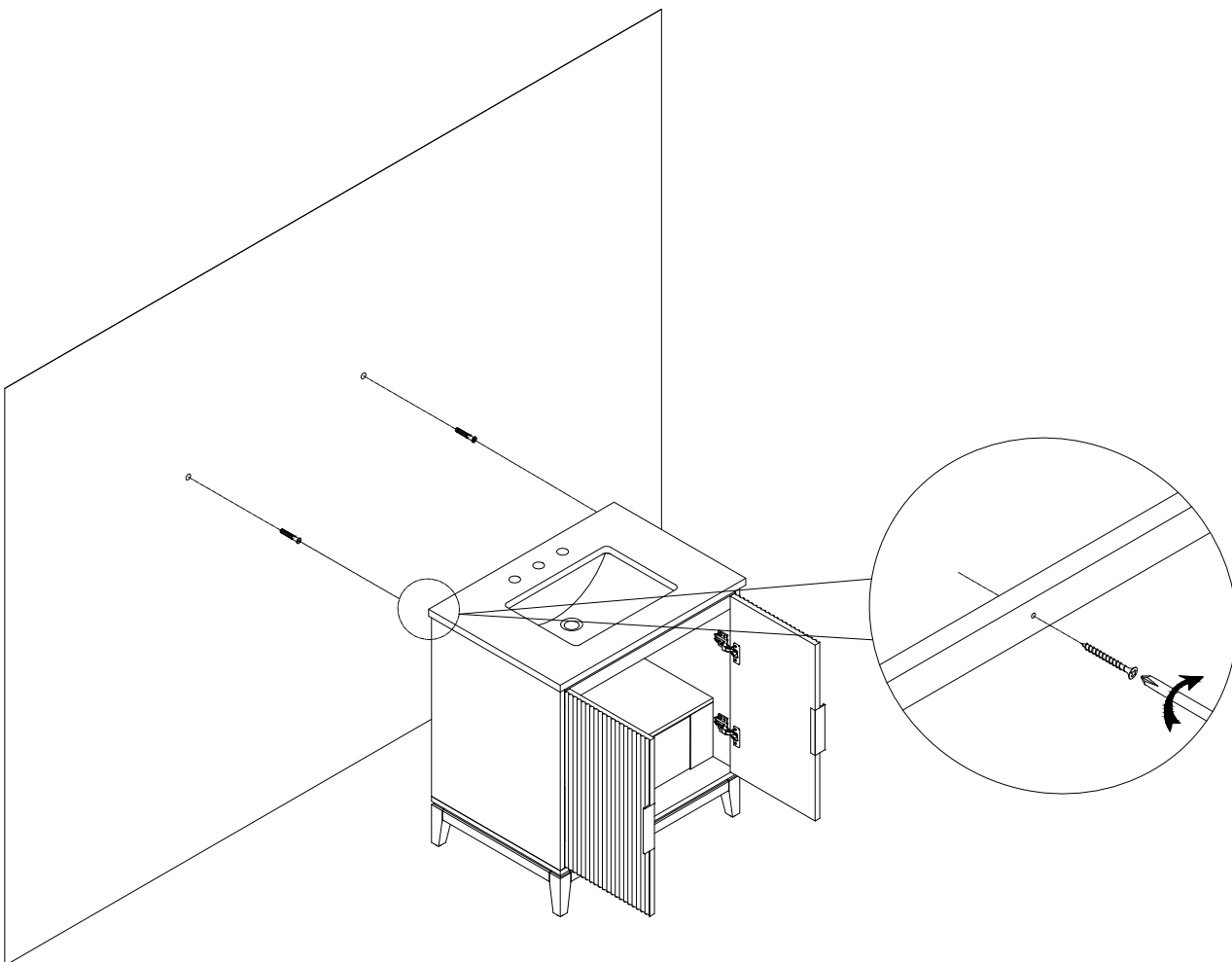

# INSTALLATION INSTRUCTION

**Fine-tune the Door Fit by Adjusting the Hinges, if Necessary.**

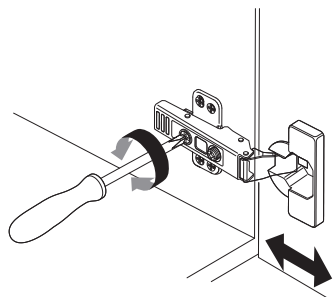

Screw A for door in & out adjustment.

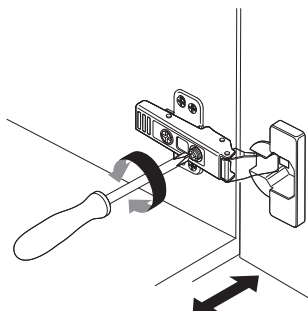

Screw B for door left & right adjustment.

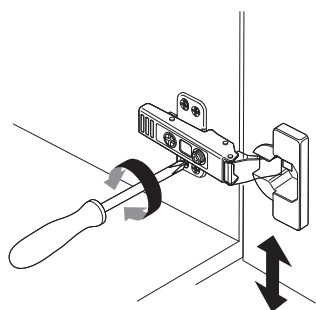

Screw C for door up & down adjustment.

**To remove or install the hinges:**

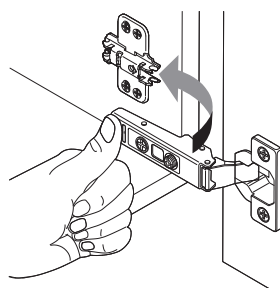

install

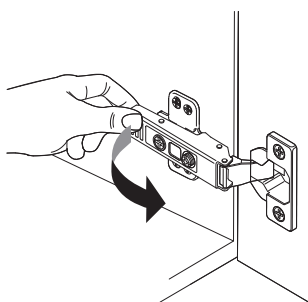

remove

# INSTALLATION INSTRUCTION

## To Remove or Reinstall the Drawers (If needed)

### To Remove the drawer, follow these steps:

- a. Fully extend the drawer and locate the colored plastic clip underneath the drawer box.
- b. Simultaneously push both levers to disengage the drawer box.
- c. Gently lift the drawer to remove it from the glide tracks. Set the drawer aside for re-installation later.

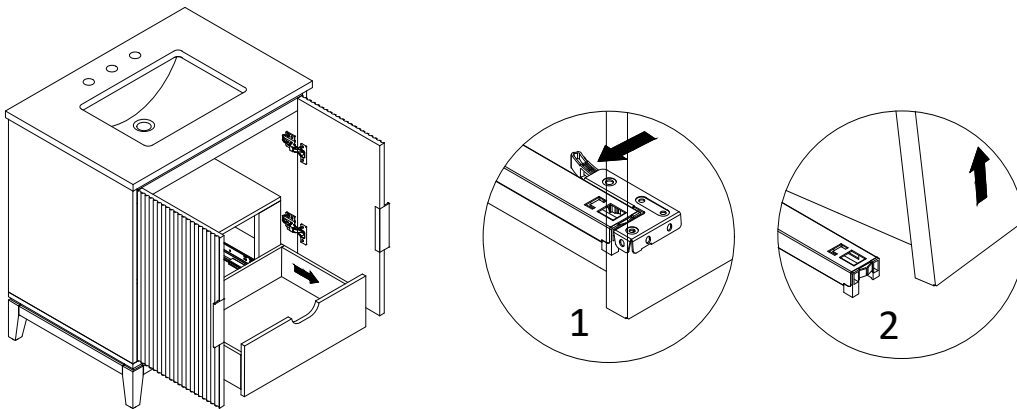

### To Reinstall the drawer, follow these steps:

- a. Fully extend the drawer glide tracks.
- b. Carefully place the back of the drawer box into the metal hook located on the back of the drawer track.
- c. Once the glide hook is inserted into the hole in the back of the drawer box, gently lower the drawer box onto the extended glide tracks.
- d. Test to ensure that the drawer box is fully engaged. If the drawer box can still be lifted off the glide track, repeat the steps from the beginning. Never force anything as it may damage the drawer or glide hardware.

### Note:

The drawer's position can be slightly adjusted up or down by twisting the adjuster knob next to the glide handles.

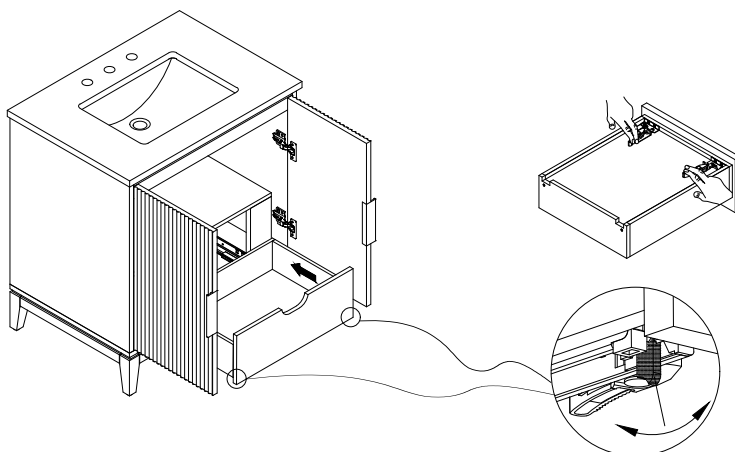

# CARE AND MAINTENANCE

By following these care guidelines, you can help preserve the appearance and longevity of your bathroom vanity.

## **For the Stone,**

It is recommended to seal your stone at least twice a year with a high-quality stone sealer. This helps prevent staining and discoloration. The need for resealing can be determined when water no longer beads on the surface. For best results, apply the sealer before using your vanity.

Keep the stone top dry and clean at all times. Immediately blot up any liquid spills gently to prevent them from penetrating the surface.

When cleaning the stone top, use a soft cloth and neutral soapy water or a cleaning product specifically designed for stones. Avoid using chemical or abrasive cleaners, as well as products containing lemon, vinegar, or other acidic substances.

Place mats or coasters under any items placed on the countertop to prevent scratching the surface.

Avoid attempting to repair larger scratches, chips, or resilient stains by yourself, as this may cause irreversible damage to the stone. Professional treatment is recommended for such issues. Contact your local stone shop for assistance.

# CARE AND MAINTENANCE

## For the Cabinet,

### 1. Regular Cleaning:

Dust the cabinet regularly with a soft, non-lint producing cloth or a household dusting product to prevent the buildup of dust and debris.

Clean the cabinet surface with a gentle, non-abrasive household cleaner suitable for painted wood surfaces.

Avoid excessive moisture and wipe the cabinet dry immediately after cleaning to prevent damage to the paint.

### 2. Avoid Harsh Chemicals:

Avoid using harsh chemicals, solvents or abrasive cleaners that can damage the painted surface. Do not use products containing acetone, bleach, ammonia, or vinegar, as they can cause discoloration or strip the paint.

### 3. Protection from Sunlight:

Avoid placing the cabinet in direct sunlight, as prolonged exposure to sunlight can cause fading and discoloration of the paint.

Use curtains or blinds to protect the cabinet from direct sunlight or consider repositioning the cabinet if necessary.

### 4. Handling Spills and Moisture

Clean up spills immediately to prevent moisture from seeping into the wood or causing damage to the paint.

Wipe off any spills with a soft cloth or paper towel and dry the surface thoroughly.

### 5. Avoid Excessive Moisture

Prevent excessive exposure to moisture, such as standing water or high humidity, as it can warp the wood or affect the integrity of the paint finish.

Ensure proper ventilation in the bathroom to minimize moisture levels.

# WARRANTY

## What does the warranty cover?

FreshSa provides one-year limited warranty on each of its vanity products, subject to normal use and proper installation by licensed professionals.

The warranty covers any defects that may arise in the materials and workmanship in products from the original date of purchase under normal home use.

This warranty is not transferrable. It extends only to the original owner and installation site for personal household use only. For commercial uses, additional limitations may apply.

## What doesn't this warranty cover?

Characteristic differences in pattern, color, mineral streaks are naturally occurring variations and are not considered defects under this warranty. Each product may vary slightly in size and finish within an acceptable industry tolerance.

This warranty does not apply where products have been improperly stored or improperly installed, misused, abused, everyday wear and tear, lack of maintenance, or modified in any way, as well as damage due to use of cleaners containing alcohol, organic solvents, or abrasives, whether performed by a service company, contractor, or yourself.

This warranty is expressly limited to the repair or replacement of the defective product(s) and does not cover installation or removal and any other incidental costs that may be incurred.

These warranties are the sole warranties of FreshSa and in lieu of all other warranties, express or implied, including any implied warranties of merchantability and fitness for a particular use.

For Item was clearly marked as a closeout, scratch and dents, liquidation, floor models or clearance items, warranty not valid.

# WARRANTY

## What will FreshSa do under the warranty?

During the warranty period, FreshSa, at its option, will

- (1) Provide free-of-charge parts necessary to resolve the issue, or
- (2) Repair or replace the product that proves to have substantial defects in materials or workmanship at the manufacturer's discretion, or
- (3) Provide an equivalent replacement product. (In keeping with our policy of continuous product improvement, FreshSa reserves the right to change specifications in design and materials and with no obligation to retrofit products we previously manufactured.)

## How do I obtain Warranty Service?

To accurately assess the damaged/defective part, FreshSa may require:

Proof of purchase, such as a receipt from the original retailer, to verify the eligibility of the warranty.

Relevant photos that clearly depict the issues. (If photos cannot be provided for any reason, the damaged/defective part must be shipped to our designated warehouse for inspection, at the customer's expense.)

## Our Guarantee

We proudly stand behind our products and are committed to doing things the right way. Should you have any questions,

# REPLACEMENT PART LIST

| Part | Description             |
|------|-------------------------|
| B    | Inside Drawer Panel *** |
| C    | Inside Drawer Box ***   |
| D    | Left Door ***           |
| E    | Right Door ***          |
| F    | Shelf ***               |
| G    | Hinge                   |
| H    | Drawer Slide (left)     |
| I    | Drawer Slide (right)    |
| J    | Handle                  |
| K    | Foot Leveler            |

**Note:**

\*\*\* Parts are made-to-order and may not have readily available in our current stock. Please contact us for the most up-to-date lead time regarding these parts.

# REPLACEMENT PART LIST

