

16 Inch Chrome Pedestal Fan



DFI660

Batch code:

Please read these instructions carefully before use and retain for future reference

**Before switching on your appliance,
always check for any damage which may have been caused in transit**

CONTENTS

Important Safety Instructions.....	3-4
Specification	5
Appliance Overview	6
Assembly Instructions.....	7
Operating Instructions.....	8
Cleaning and Maintenance	8
Fuse Replacement.....	8
Trouble Shooting Guide.....	9
Disposal Information.....	9
Igenix Warranty Terms and Conditions.....	10-11

IMPORTANT SAFETY INSTRUCTIONS

Read and follow all of the instructions even if you feel you are familiar with the product, and find a place to keep this manual handy for future reference.

Important: This appliance is intended for use in a domestic environment only. Any other use is not recommended by the manufacturer and may cause fire, electrical shocks or other injury to user or property. When using electrical appliances, basic safety precautions should always be followed:

- Before plugging in the appliance, check that the voltage indicated on the rating label corresponds with the main voltage in your home.
- Do not operate the unit with a damaged cord or plug, after it malfunctions or has been dropped or damaged in any way. Return to an authorised service facility for examination and repair.
- Ensure that the air inlets and outlets are not blocked or covered.
- Do not place the unit too close to curtains or other objects - min 30cm.
- Make sure there are no objects near the unit which can prevent it from oscillating.
- Never insert fingers, pencils or other objects into the unit if the power cord is plugged in, and especially not during the operation. Warn your children against these dangers.
- This appliance should only be used by adults.
- This appliance is not intended for use by persons (including children) with reduced physical, sensory or mental capabilities, or lack of experience and knowledge.
- Keep the appliance and its cord out of reach of children.
- Children shall not play with the appliance.
- Cleaning and user maintenance shall not be made by children.
- Unplug the unit from the socket when not in use. Do not pull on the cord.

- Do not use the unit near bath, shower, swimming pool or anywhere it could be splashed with water.
- Do not expose the unit to direct sunlight.
- Do not immerse the appliance or the electrical cord or plug in any type of liquid.
- Do not use the appliance near a source of heat.
- Do not use the unit near flammable or explosive gases.
- Before cleaning the unit, switch it off and unplug the power cord.
- Do not leave the unit unattended during operation. Always unplug the power cord when not in use.
- To repair the unit, take it to a qualified service engineer. Repairs carried out by unqualified people may cause damage to the unit or injury to persons or property and void the warranty.

SPECIFICATION

Model No:	DFI 660
Brand	Igenix
Colour	Chrome
Wattage (W)	45 W
Frequency (Hz)	50 Hz
Voltage (V)	220-240 V
Product Dimensions (mm)	H 1300 x W 400 x D 400 mm
Net Weight (kg)	5.4 kg
Oscillation Function	Yes
Overheat Protection	Yes
Speeds	Low, Medium, High

APPLIANCE OVERVIEW

Fig 1:

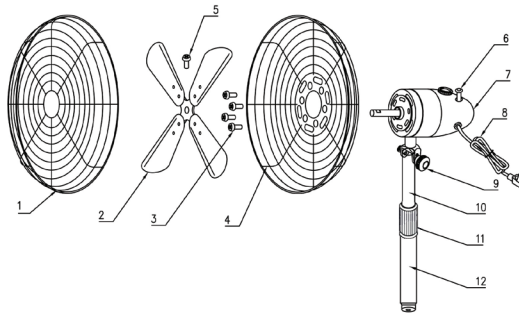

- 1. Front Guard
- 2. Blade
- 3. Screws
- 4. Rear Guard
- 5. Fan Blade Screw
- 6. Oscillation Knob
- 7. Fan Head (Motor)
- 8. Power Cord
- 9. Adjusting Knob
- 10. Inner Tube
- 11. Height Adjustment Lock
- 12. Outer Tube

Fig 2:

Fan Head (Motor)

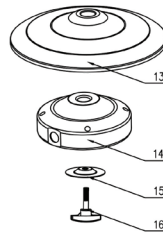
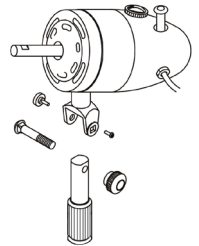

ASSEMBLY INSTRUCTIONS

Fan Assembly

- Position the rear guard over the motor shaft, ensuring that the notches are correctly aligned and then secure in place with the four screws.
- Align the fan blade with the flat part on the motor shaft and slot into place and secure by tightening the fan blade screw fully.
- Position the front guard against the rear guard and hold together, close each clip and then tighten the screw and the nut at the bottom of the guard.

Stand Assembly

- Insert the pole (inner and outer tube) into the base.
- Carefully tilt, so that the pole and the base are lying horizontally on the floor.
- Slot the base weight onto the bottom of the base
- Place the nut slice onto the bolt and then screw into the bottom of the base weight, tighten securely.
- Return the stand to an upright position.
- Unscrew the height adjustment lock and pull up the inner tube to adjust the height, ensuring that the lock is fully tightened before proceeding.
- Position the fan head motor either side of the pole as shown in fig 2 and insert the tilt control bolt through the square hole of the bracket and the lower holes of the inner tube.
- Fully tighten the small screw that is already located in the bracket and then fit the knob onto the tilt control bolt and lightly tighten.
- Insert the position knob through the top hole of the bracket, adjust the fan head to the desired position and firmly tighten both position and tilt control knobs.

OPERATING INSTRUCTIONS

1. Ensure the control knob is in the off position (0) and then plug in.
2. Adjust the fan speed by twisting the control knob
0 = Off
I = Low
II = Medium
III = High
3. To oscillate fan, push the oscillate knob down, which is located at the top of the fan head (motor). To stop oscillation, pull up the same knob.
4. To change the angle of the fan, loosen large tilt control knob and the smaller locking screw, adjust fan head to the desired position and re-tighten.
5. Use the height adjustment lock to raise or lower the fan. Ensure the lock is fully tightened.

CLEANING AND MAINTENANCE

1. Switch off and remove plug from the socket.
2. Remove the front guard.
3. Wipe blades with a soft damp cloth, taking care not to alter the angle of the blades. Allow to dry or wipe with a soft dry cloth.
4. Replace the front guard.
5. If necessary, you can use a soft brush or vacuum cleaner to remove dust from the guards.
6. Ensure that the fan has been reassembled fully before use.

MAINS PLUG FUSE REPLACEMENT

Fuse Replacement (Class I)

This appliance must be earthed. Remove the fuse cover with a small flat head screw driver. Take out the fuse and replace with a new fuse of the same Amp. Replace the fuse cover and push back into place.



TROUBLE SHOOTING GUIDE

If you experience difficulties with the appliance, please check the suggestions below before contacting customer services on 01473 271272:

Problem	Possible Cause	Possible Solution
The appliance does not work.	The appliance is not properly plugged into the wall socket.	Plug the appliance in firmly.
	The appliance is not switched on.	Make sure the appliance is switched on.
	There is no electricity running through the mains wall socket.	Check the fuse or breaker.

DISPOSAL INFORMATION

The European Directive 2012/19/EU on Waste Electrical and Electronic Equipment (WEEE), requires that old household electrical appliances must not be disposed of in normal unsorted municipal waste.

Old appliances must be collected separately in order to optimise the recovery and recycling of the materials they contain and reduce the impact on human health and the environment.

The crossed out “wheeled bin” symbol on the product reminds you of your obligation, that when you dispose of the appliance it must be separately collected. Consumers should contact their local authority or retailer for information concerning the correct disposal of their old appliance.





Igenix Warranty Terms & Conditions

This product is guaranteed for a period of 12 months as standard from the date of purchase against mechanical and electrical defects. You can extend your warranty for a further 12 months by registering your product.

Upon registration we will cover your product for a period of 24 months from the original purchase date against any mechanical or electrical defects.

To qualify for the guarantee, the product must be used for domestic household use only and in accordance with the instructions in the user manual. Any misuse of the product will result in the warranty being void.

The guarantee does not cover accidental damage, misuse, neglect, tampering or incorrect adjustment or installation.

The guarantee will be rendered invalid if the product is resold, has had its serial number removed (or has an invalid serial number), or if an unauthorised person has carried out any repairs or alterations.

The warranty does not cover accessories or consumable parts that require replacement under normal use. This includes shelving, dials, filters, belts and trays etc.

In the unlikely event of a breakdown please refer to the Troubleshooting guide in your user manual and check all plugs, fuses and the electricity supply.

If you still require assistance please contact our Customer Service department on **01473 271 272** or write to us at the following address:

**Customer Service Department
38 Bluestem Road, Ransomes Europark
Ipswich, IP3 9RR**

Please quote the Product Code which begins 'IG' or 'DF' and the Batch Code beginning '5' and give details of the exact fault. We will then decide whether to repair or replace the item.

Before we arrange the repair or replacement you will be required to return a copy of your proof of purchase. Please retain your original.

If an item is replaced within the agreed guarantee period, the guarantee for the replacement item will be calculated from the purchase date of the original.

In the event that the product is inspected and no fault is found or the product is not within the guarantee period you will be charged for the repair and any carriage costs.

igenix

Thank you for choosing Igenix

As a valued customer we would like to offer you a FREE 2 year warranty to cover your product against any electrical or mechanical defects.

This means that in the unlikely event you develop a fault or problem with your product we will happily repair or replace the item free of charge.

To qualify for the 2 year warranty you must register your product within 30 days of purchase. The full Terms & Conditions of our warranty policy are shown on the opposite page. They are also available on our website. **www.igenix.co.uk**

To register your product, please complete all sections of the form below and return to us at the following address: Igenix, 38 Bluestem Road, Ransomes Europark, Ipswich, IP3 9RR.

Alternatively you can visit the Igenix website and complete the form online.

Customer Details:

Title: _____ First Name _____ Surname: _____

Address: _____

Post Code: _____

Email: _____

Telephone: _____

Product Information:

Product Code (Beginning IG or DF): _____ Product Description: _____

Batch Number (Beginning 5): _____ Serial Number (if applicable): _____

Date of Purchase: _____

Retailer Name: _____

Retailer Location: _____

Please tick here to confirm you have read and accept our Terms & Conditions

Please tick here if you DO NOT wish to receive marketing information from us

Customer Signature: _____ Date: _____

igenix

38 Bluestem Road, Ransomes Europark, Ipswich, IP3 9RR

Tel. 01473 271 272

Disclaimer: Igenix operate a policy of continual improvement and development.
We therefore reserve the right to change/alter the specification and appearance of our appliances without prior notice.
All diagrams and images shown in this manual are for illustration purposes only.