

Easy Assembly

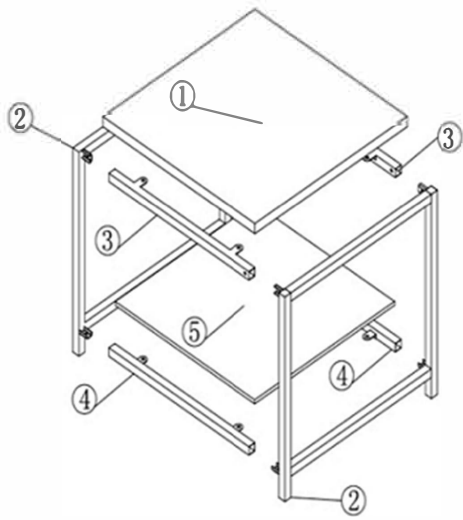

Parts List:

- 1 (x1) Bamboo table top
- 2 (x2) Frame
- 3 (x2) Top cross bar
- 4 (x2) Bottom cross bar
- 5 (x1) Lower bamboo shelf

Parts List:

- A (x8) Screws for crossbar to frame
- B (x4) Long screws
- C (x4) Short screws
- D (x1) Allen wrench

Note: Phillips screwdriver will be necessary to complete assembly and is not included

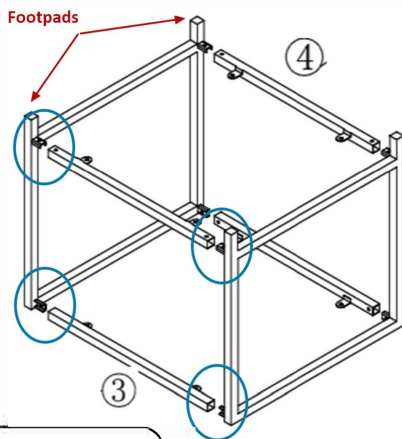

Step 1

Table is shown upside down, footpads with red arrows above, will be in the air. Part 3 top cross bar (two pieces) aligns with top, now on floor, while Part 4 cross bar (two pieces) aligns near footpads.

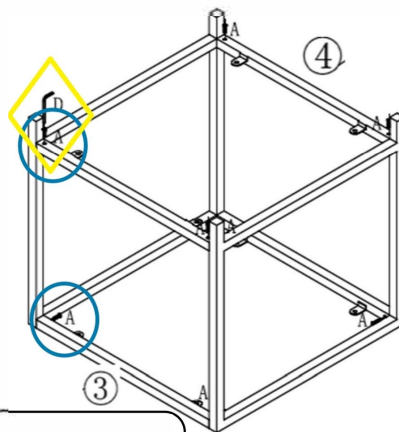

Step 2

Using the allen wrench (D, highlighted in yellow diamond above), tighten crossbars to frame with screws A (blue circle above) on all four sides, top and bottom. All four parts, 2 of Part 3 and 2 of Part 4 are now tightened to frame.

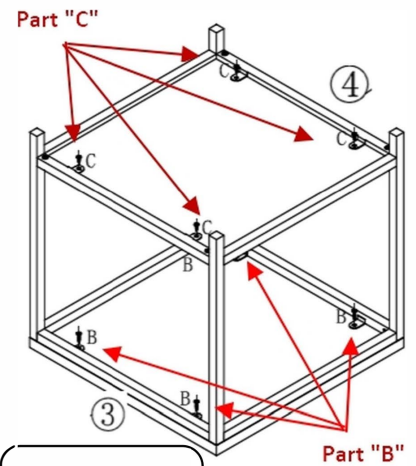

Step 3

With the table still upside down, use a phillips screwdriver to attach top bamboo piece using Part B long screws, and lower bamboo shelf piece using part C short screws. Flip rightside up and ready for use.