

ASSEMBLY INSTRUCTIONS

X - BACK SIDE CHAIR

Reading struction carefully priorto assembly





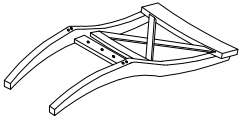
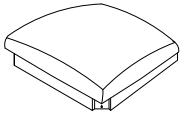
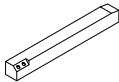

Thank you for purchasing this quality product. Check carefully for small parts which may have come loose during shipment.

Remove all components from pack and place table top upside down on softsurface such as carpet or clothto prevent scratching the finish. Identify and count all parts as specified below. Do not tighten bolts until assembly is complete.

"PART LISTS"

STT	DESC	OUTLOOK	Q'TY
1	CHAIR BACK		1pc
2	SEAT FRAME		1pc
3	CHAIR LEGS		2pc

"HARDWARE LISTS"

STT	OUTLOOK	SIZE	Q'TY
A		5/16" x 3" BOLT	4pcs
B		5/16"x2 " BOLT	4pcs
C		5/16"x1 1/2" BOLT	2pcs
D		5/16" SPRING WASHER	10pcs
E		5/16"x19mm LOCK WASHER	10pcs
F		4mm ALLEN WRENCH	1pc

STEP 1

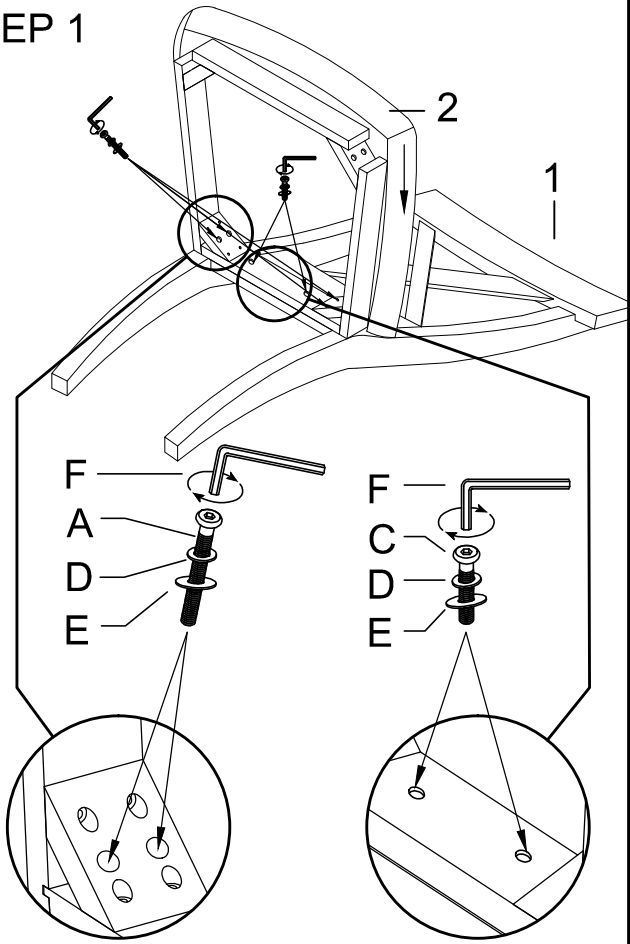

STEP 2

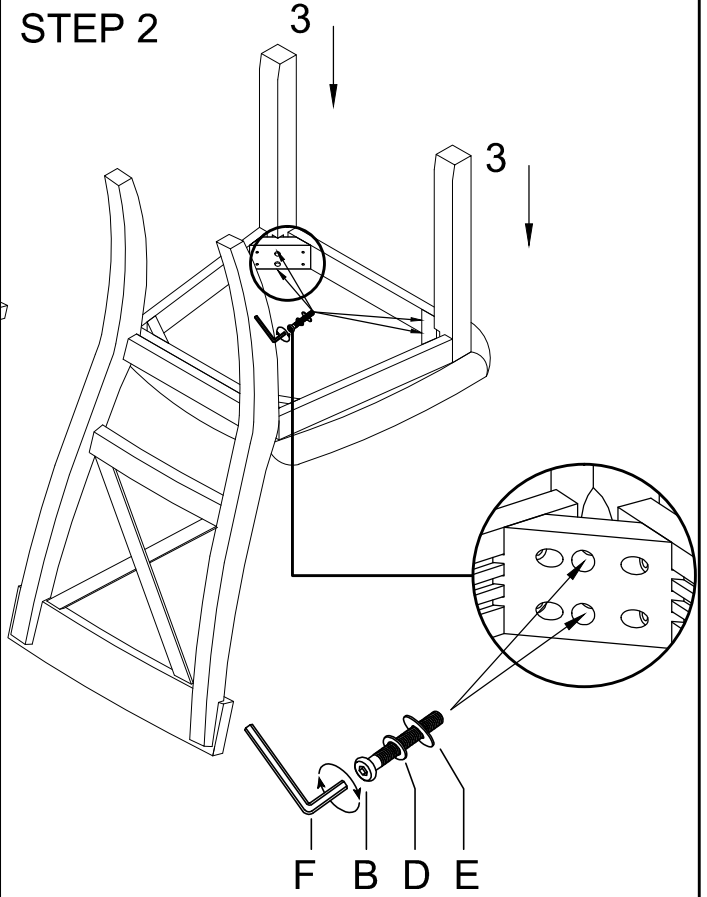

FINAL

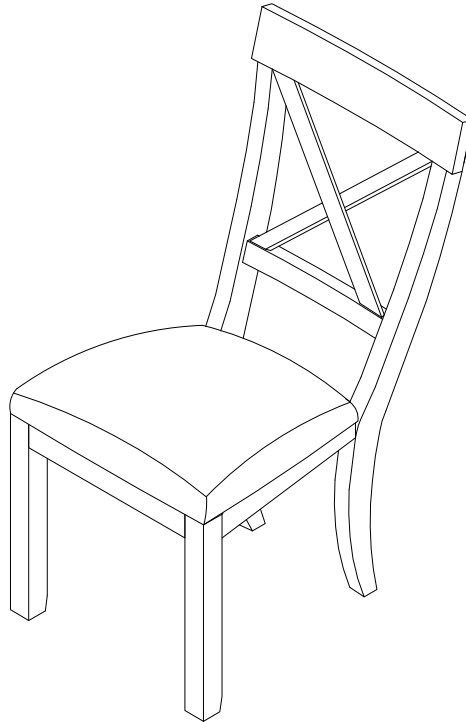

ASSEMBLY INSTRUCTIONS

BENCH

Reading struction carefully priorto assembly



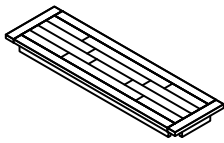
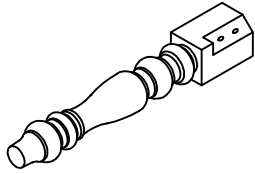

Thank you for purchasing this quality product. Check carefully for small parts which may have come loose during shipment.

Remove all components from pack and place table top upside down on softsurface such as carpet or clothto prevent scratching the finish. Identify and count all parts as specified below. Do not tighten bolts until assembly is complete.

"PART LISTS"

STT	DESC	OUTLOOK	Q'TY
1	TABLE TOP		1pc
2	TABLE LEGS		4pcs

"HARDWARE LISTS"

STT	OUTLOOK	SIZE	Q'TY
A		5/16"x 1 3/4" BOLT	8pcs
B		5/16" SPRING WASHER	8pcs
C		5/16"x19mm LOCK WASHER	8pcs
D		4mm ALLEN WRENCH	1pc

STEP 1

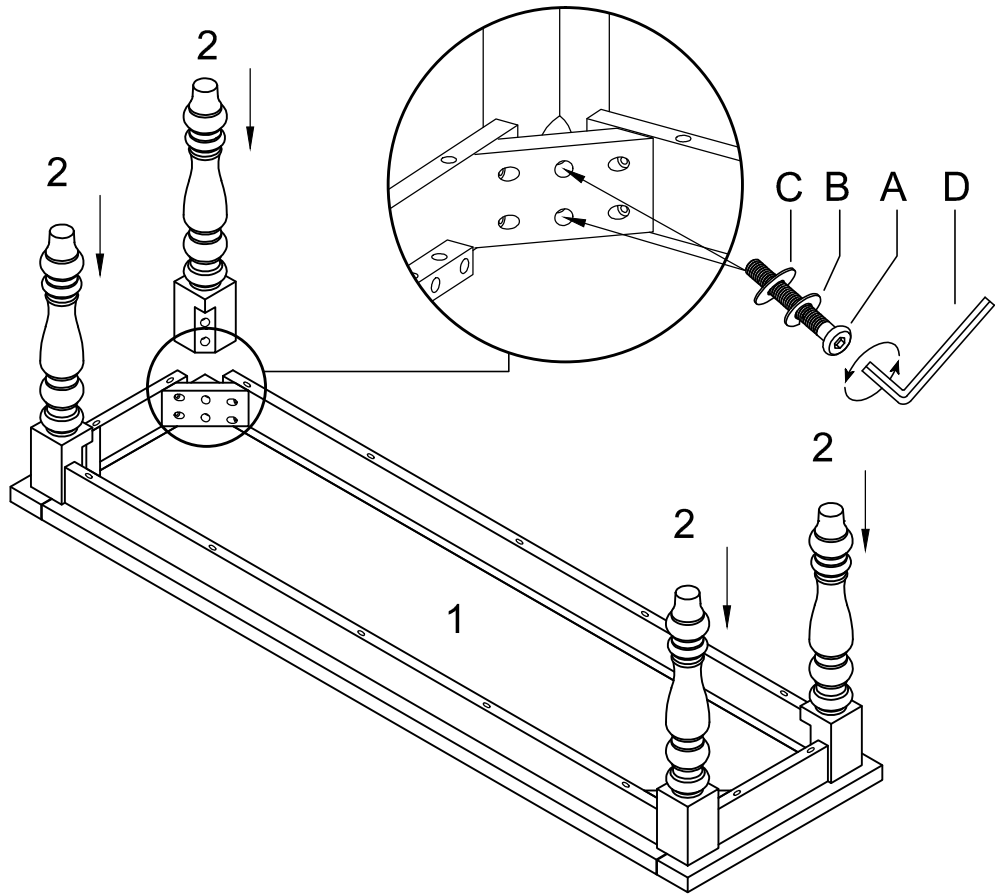

FINAL

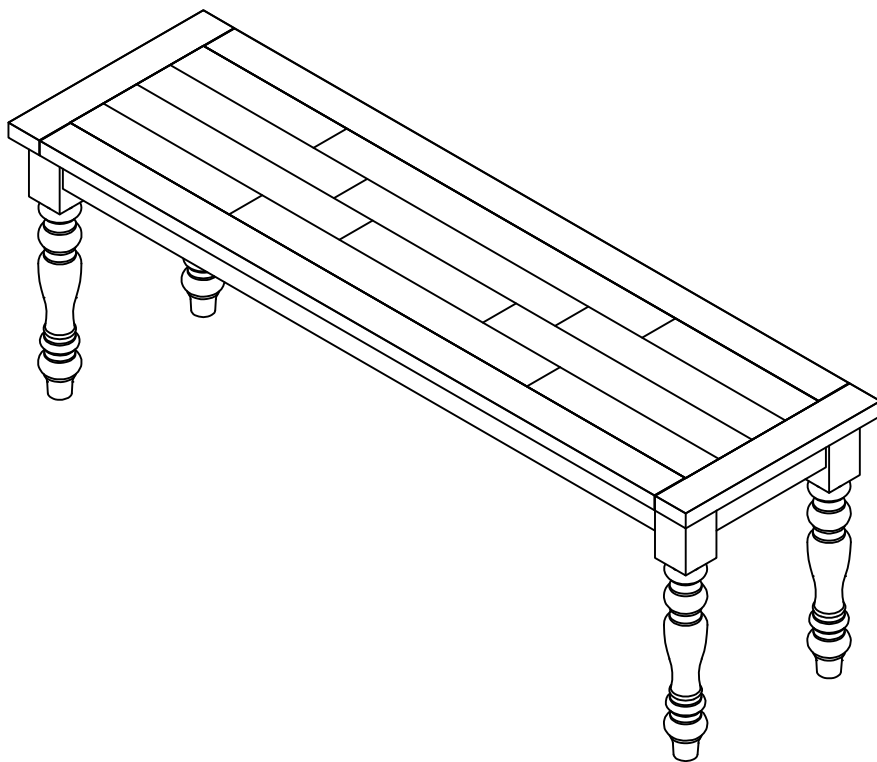

ASSEMBLY INSTRUCTIONS

RECTANGLE DINING TABLE

Reading struction carefully priorto assembly



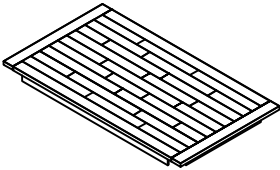
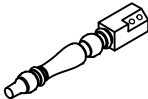

Thank you for purchasing this quality product. Check carefully for small parts which may have come loose during shipment.

Remove all components from pack and place table top upside down on softsurface such as carpet or clothto prevent scratching the finish. Identify and count all parts as specified below. Do not tighten bolts until assembly is complete.

"PART LISTS"

STT	DESC	OUTLOOK	Q'TY
1	TABLE TOP		1pc
2	TABLE LEGS		4pcs

"HARDWARE LISTS"

STT	OUTLOOK	SIZE	Q'TY
A		5/16"x 2 1/4" BOLT	8pcs
B		5/16" SPRING WASHER	8pcs
C		5/16"x19mm LOCK WASHER	8pcs
D		4mm ALLEN WRENCH	1pc

STEP 1

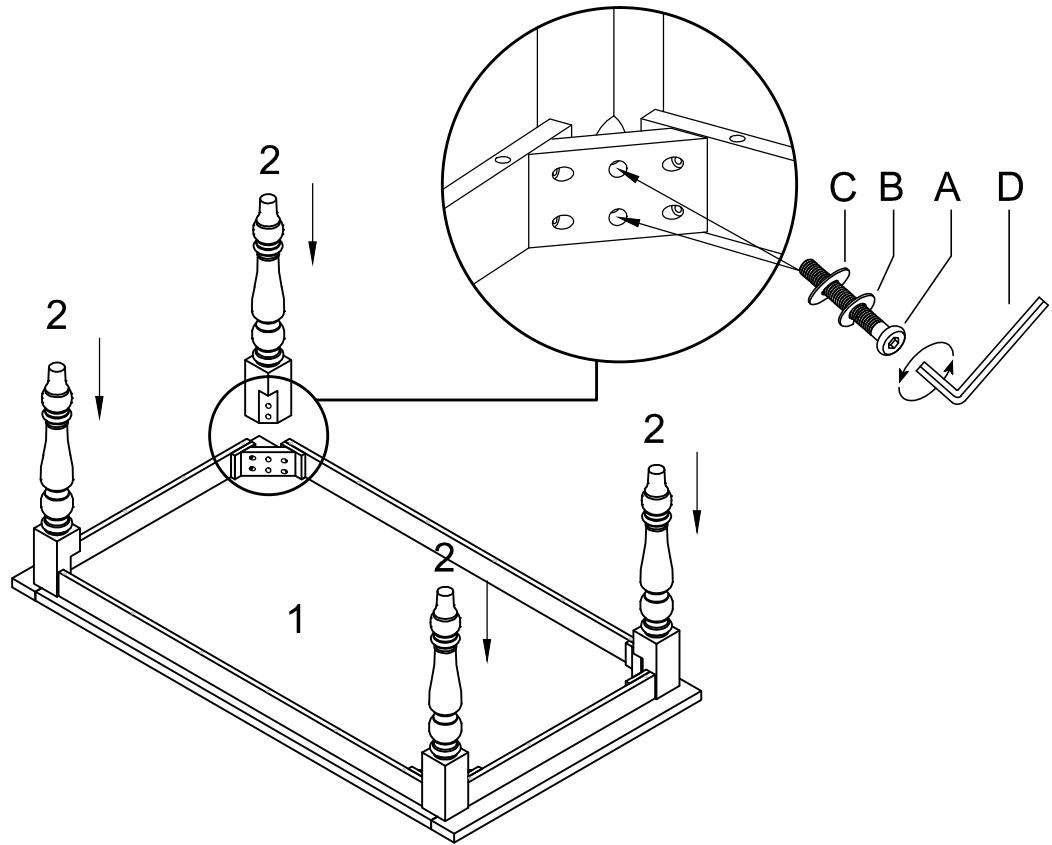

FINAL

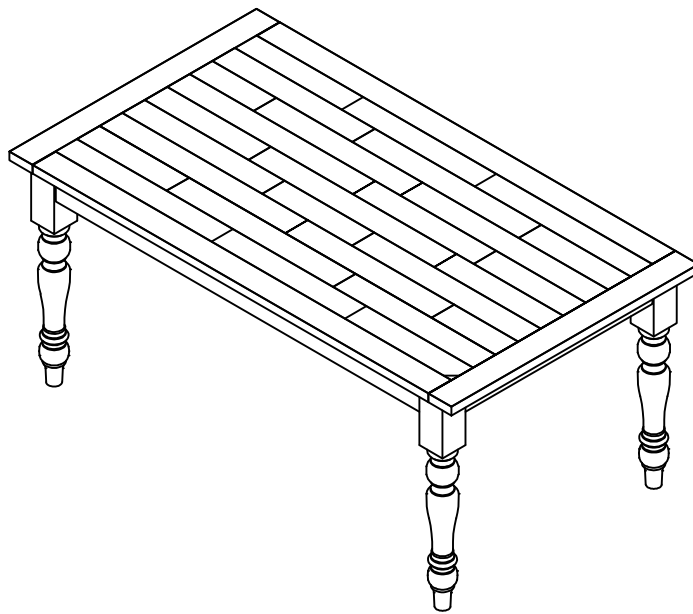

ASSEMBLY INSTRUCTIONS





ROUND DINING TABLE TOP/BASE

Reading struction carefully prioerto assembly



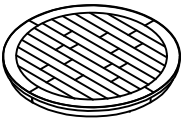

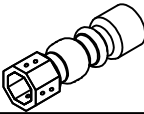

Thank you for purchasing this quality product. Check carefully for small parts which may have come loose during shipment.

Remove all components from pack and place table top upside down on softsurface such as carpet or clothto prevent scratching the finish. Identify and count all parts as specified below. Do not tighten bolts until assembly is complete.

"PART LISTS"

STT	DESC	OUTLOOK	Q'TY
1	TABLE TOP		1pc
2	PANEL		1pc
3	TABLE POST		1pc
4	TABLE LEGS		4pcs

"HARDWARE LISTS"

STT	OUTLOOK	SIZE	Q'TY
A		5/16"x1/2" BOLT	4pcs
B		5/16"x1/4" BOLT	2pcs
C		5/16" SPRING WASHER	14pcs
D		5/16"x19mm LOCK WASHER	14pcs
E		4mm ALLEN WRENCH	1pc
F		12mm NUT	8pcs
G		12mm ALLEN KEY	1pc

Remove Panel from Top Table.

Note : Hardware removed step 1 using assembly for next step .

STEP 1

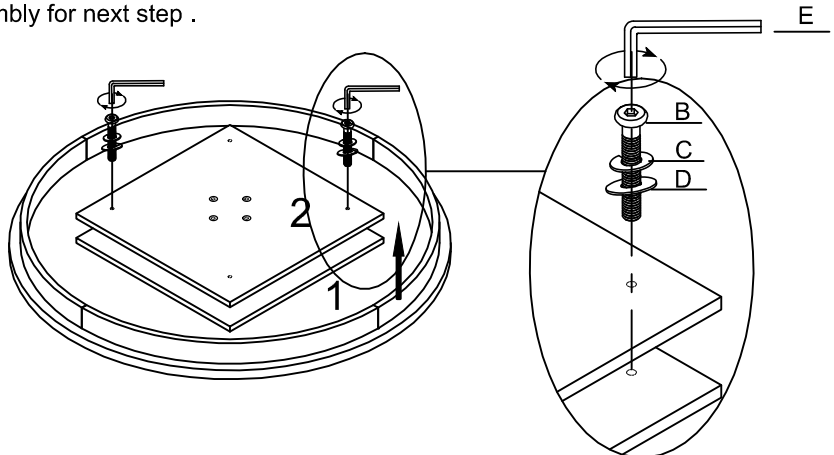

STEP 2

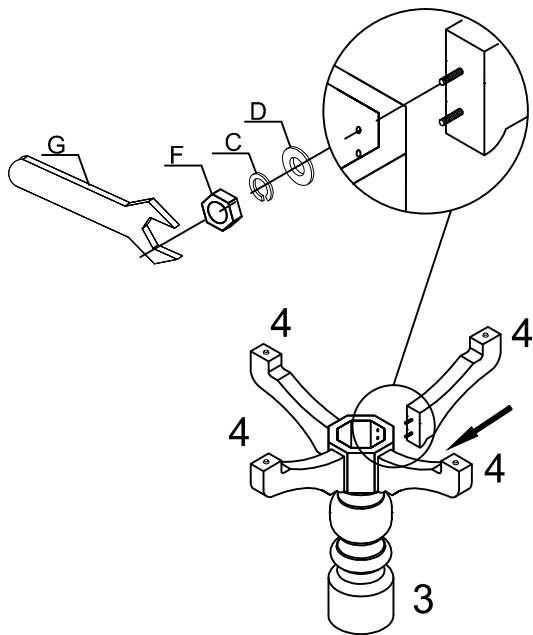

STEP 3

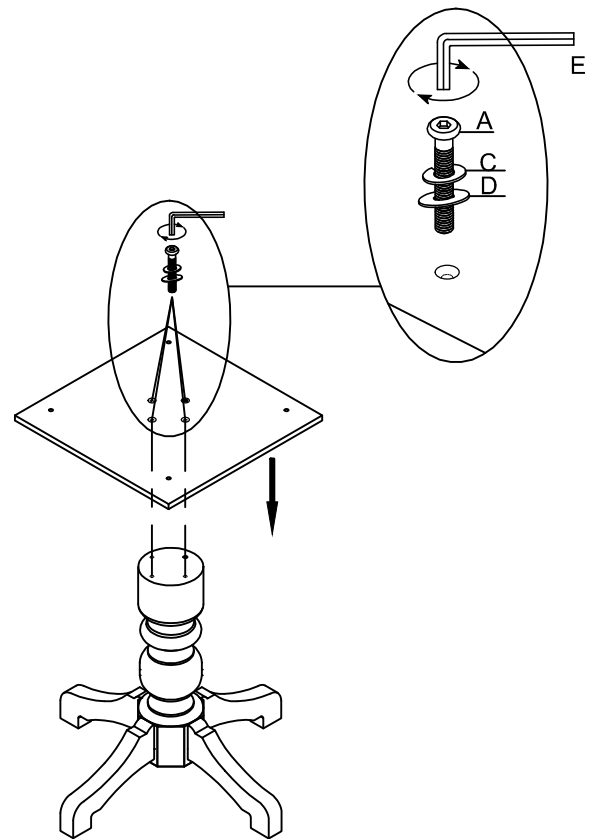

STEP 4

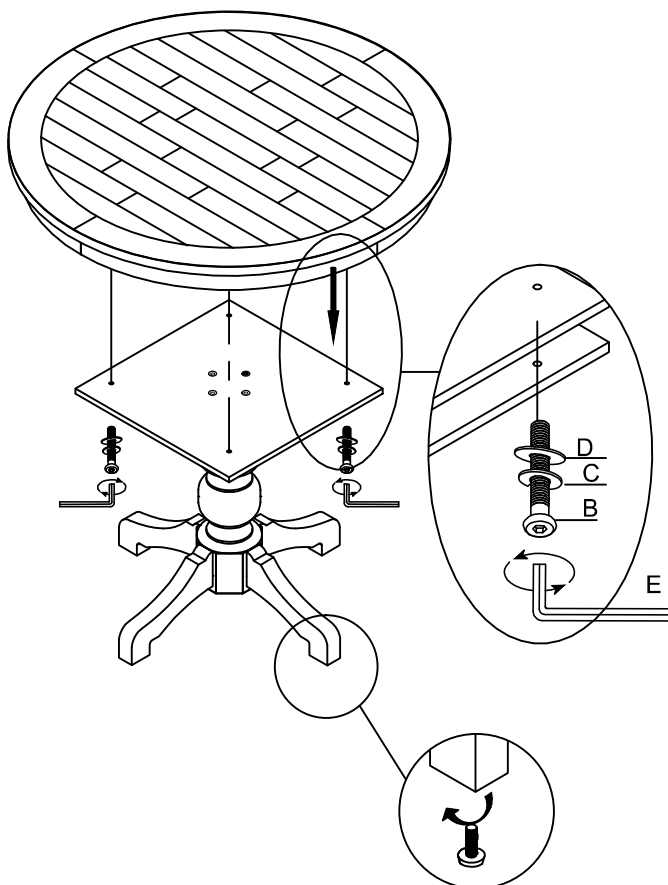

FINAL

