

ASSEMBLY INSTRUCTIONS

WHITE

HARDWARE LIST

NO.	Sketch	Description	Qty
1		Bolt(1/4"*7/8")	10 PCS
2		Bolt(1/4"*1-1/4")	8 PCS
3		Spring Washer(1/4")	18PCS
4		Washer(1/4")	18 PCS
5		Allen wrench(4mm)	1 PC

PARTS LIST

NO.	Sketch	Description	Qty
A		Table top	1 PC
B		Wing Panel	2 PCS
C		Pedestal	2 PCS
D		Base Ring	1 PC

Step 1

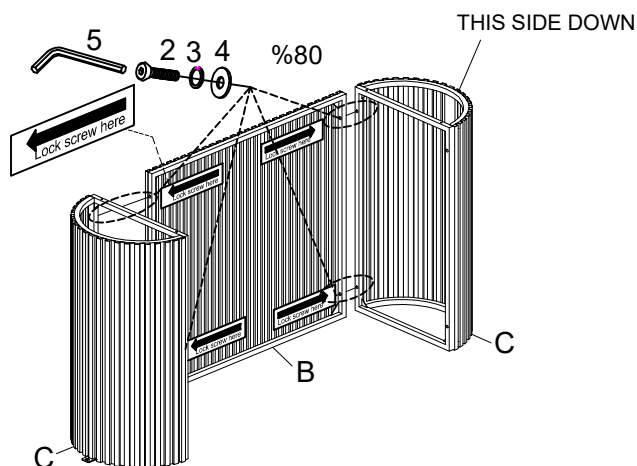

In this step, tighten the screws to 80%.
Note: Do not lock the screws.

Step 2

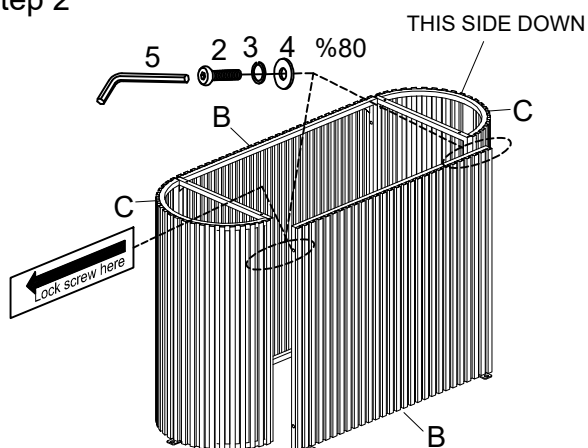

In this step, tighten the screws to 80%.
Note: Do not lock the screws.

Step 3

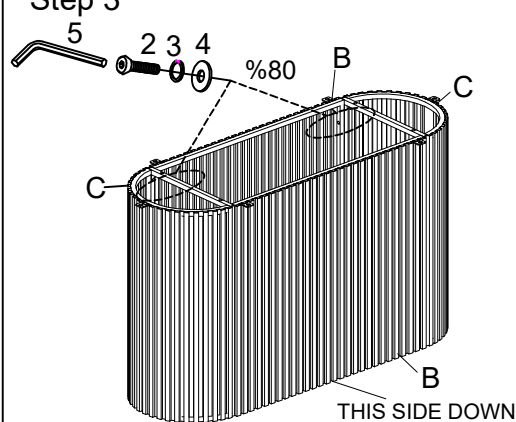

With the assistance of an adult partner, place the base upside down. Then, lock the Wing Panel (B) and Pedestal (C).
In this step, tighten the screws to 80%.
Note: Do not lock the screws.

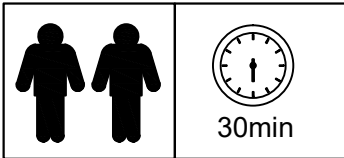

ASSEMBLY INSTRUCTIONS

WHITE

Step 4

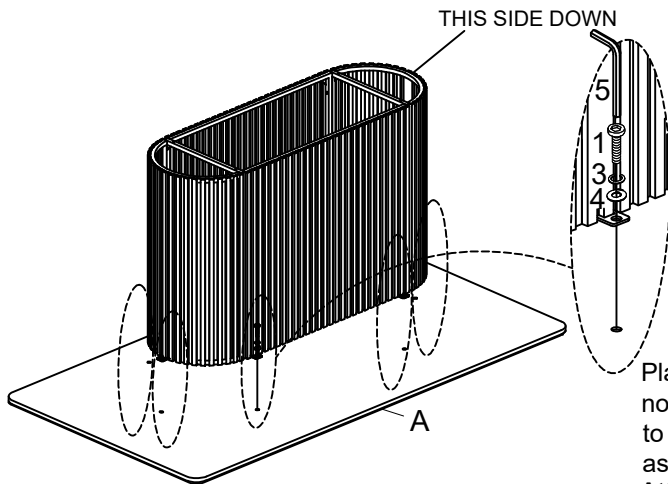

Place the tabletop facedown on a clean, non-marring surface. Attach the table base to the bottom of the tabletop using screws, as shown in the pictures.
Attention: When locking the tabletop, please use Short Bolt(1).

Step 5

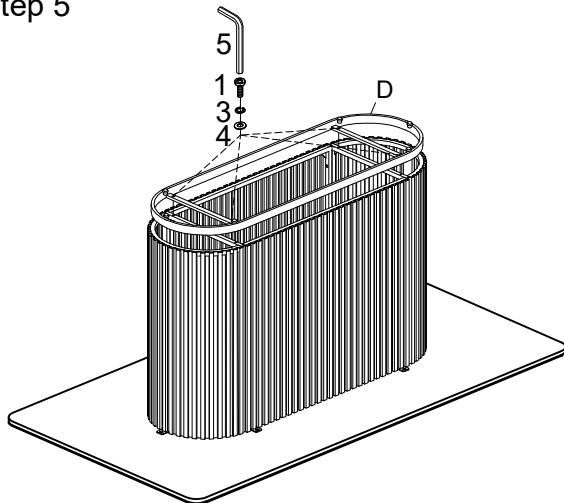

Step 6

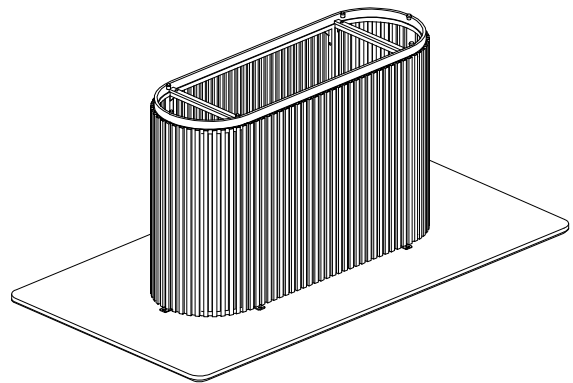





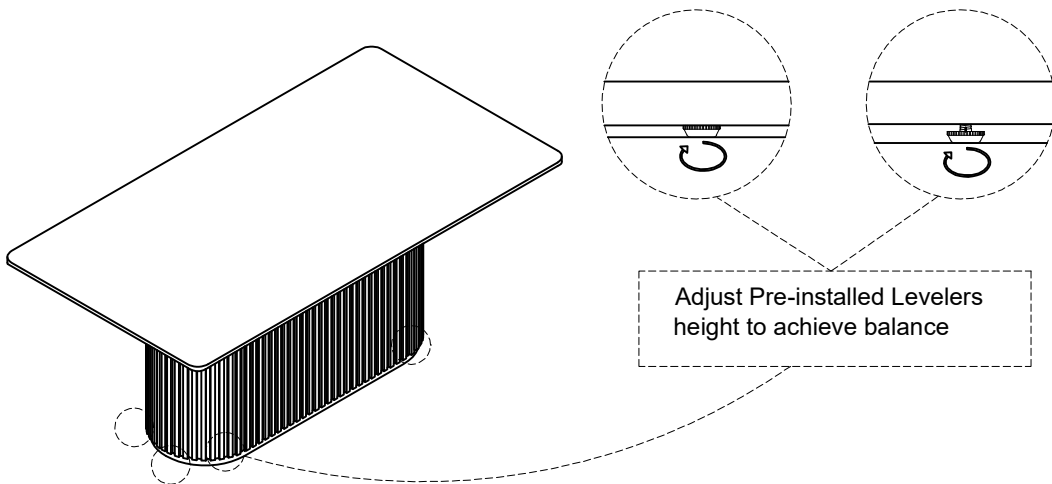

Note: Fully tighten all bolts at this step.

Step 7





ASSEMBLY INSTRUCTIONS

HARDWARE LIST

NO.	SKETCH	DESCRIPTION	QTY
A		Bolt(5/32"x5/32")	4 PCS
B		Bolt(1/4"x2-1/8")	4 PCS
C		Spring Washer(1/4")	4 PCS
D		Washer(1/4")	4 PCS
E		Allen wrench(4mm)	1 PC
F		Allen wrench(2mm)	1 PC

PARTS LIST

NO.	SKETCH	DESCRIPTION	QTY
1		Seat	1 PC
2		Backrest	1 PC
3		Metal frame	1 PC

Step 1

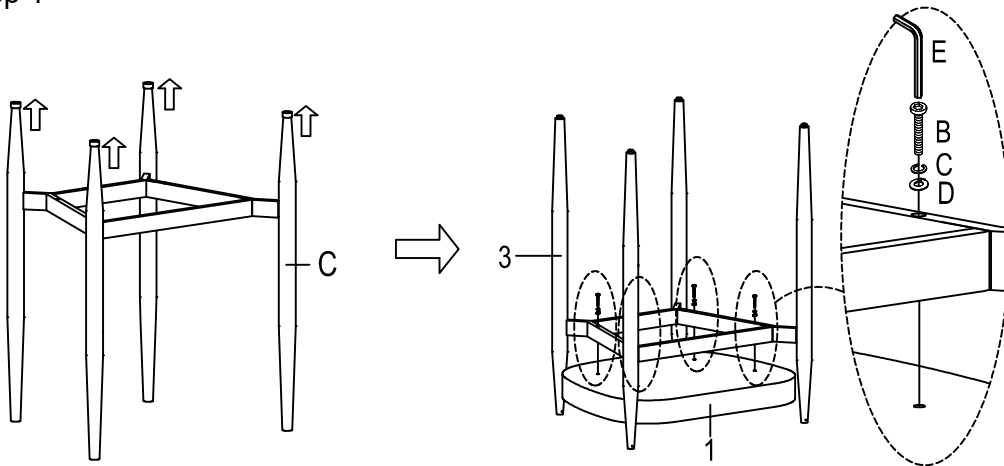

Step 2

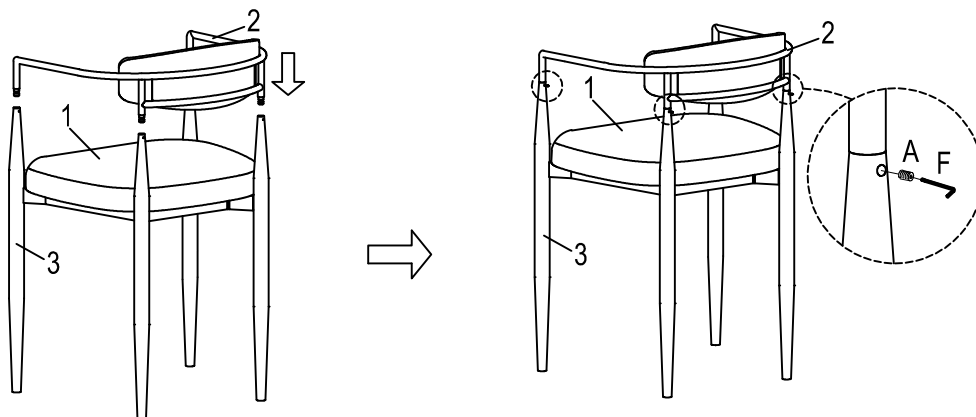

ASSEMBLY INSTRUCTIONS

Step 3

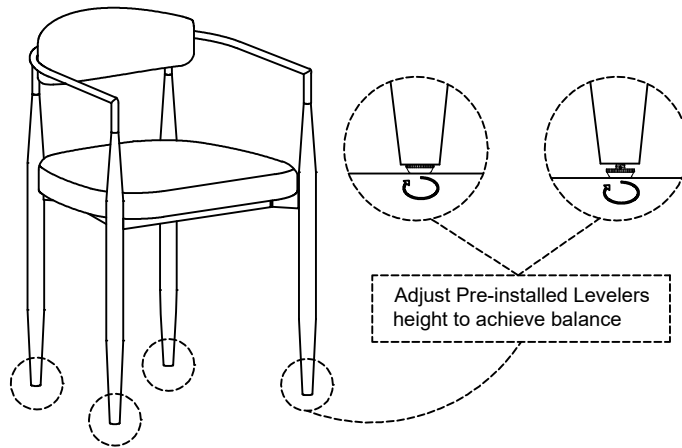

Step 4

