

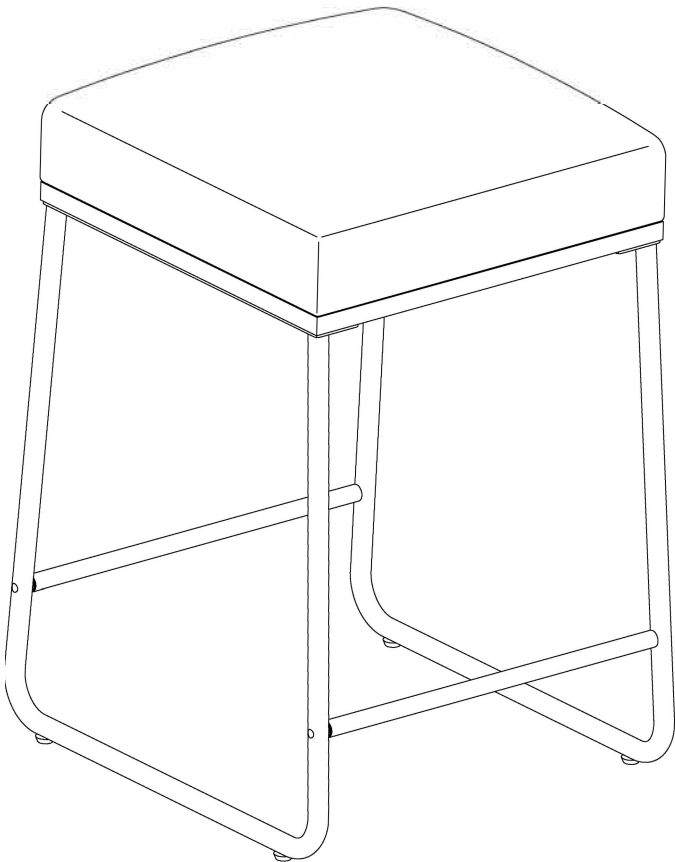

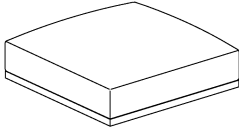

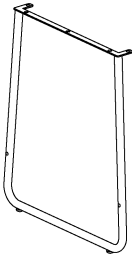

**Counter Stool
Bar Stool**

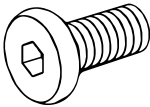
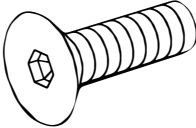

PART LIST

<p>A</p> 	<p>B</p> 	<p>C</p> 
<p>Seat 2 PCS</p>	<p>Leg 4 PCS</p>	<p>Stretcher 4 PCS</p>

HARDWARE LIST

<p>#1</p>  <p>1/4"x3/4"L</p>	<p>#2</p>  <p>1/4"x1-1/4"L</p>	<p>#3</p> 	<p>#4</p> 	<p>#5</p> 
<p>Bolt 20 PCS (Extra 2)</p>	<p>Long Bolt 8 PCS (Extra 2)</p>	<p>Spring Washer 20 PCS (Extra 2)</p>	<p>Flat Washer 20 PCS (Extra 2)</p>	<p>Allen Wrench 1 PC</p>

Step 1. Lay seat (part A) upside down on a soft flat surface, such as carpet. Attach leg (part B) to seat (part A) using bolts (part #1), spring washers (part #3), flat washers (part #4) and allen wrench (part #5).

NOTE: Please do not fully tighten bolts until unit is fully assembled.

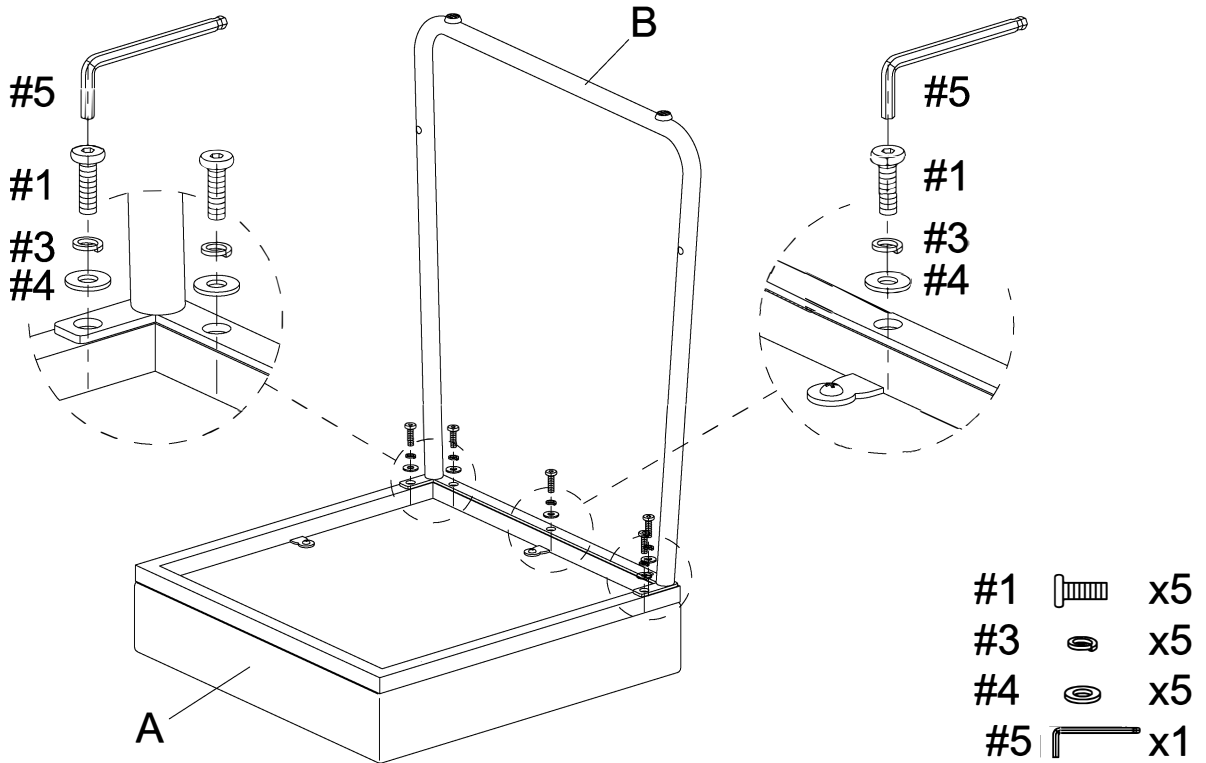

Step 2. Attach stretchers (part C) to leg (part B) using long bolts (part #2) and allen wrench (part #5).

NOTE: Please do not fully tighten bolts until unit is fully assembled.

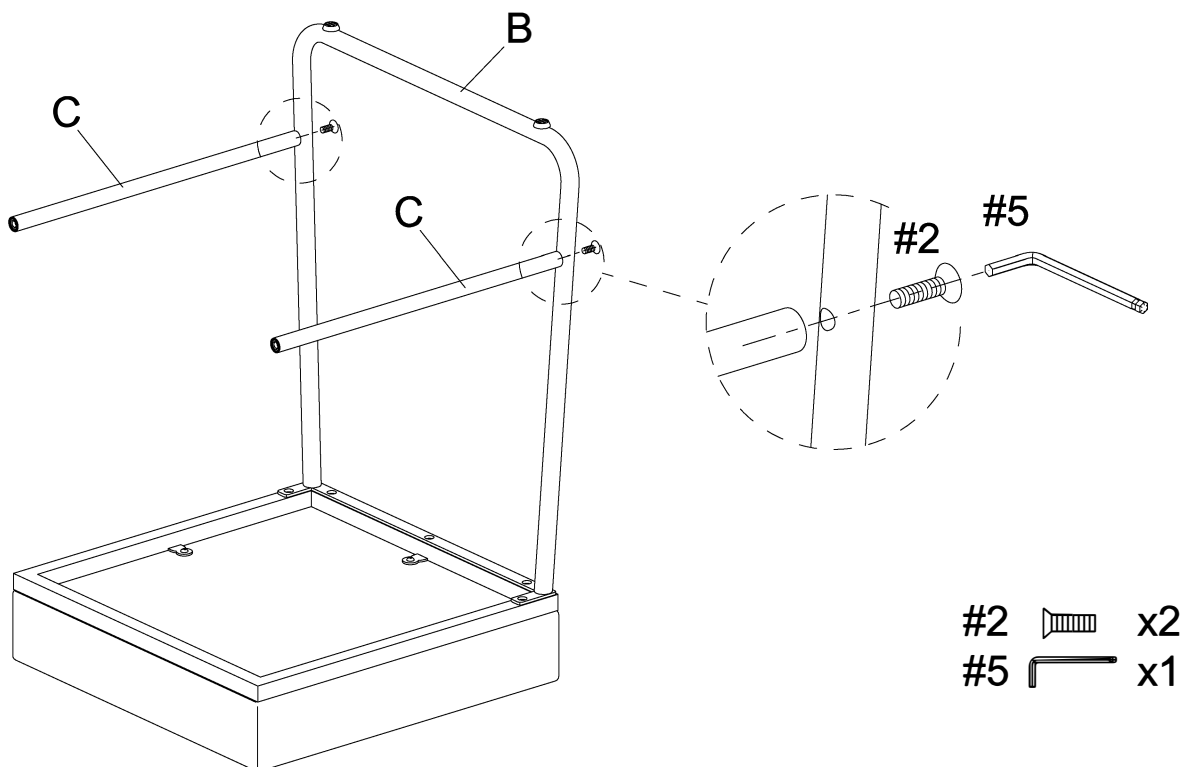

Step 3. Attach leg (part B) to seat (part A) using bolts (part #1), spring washers (part #3), flat washers (part #4) and allen wrench (part #5).

NOTE: Please do not fully tighten bolts until unit is fully assembled.

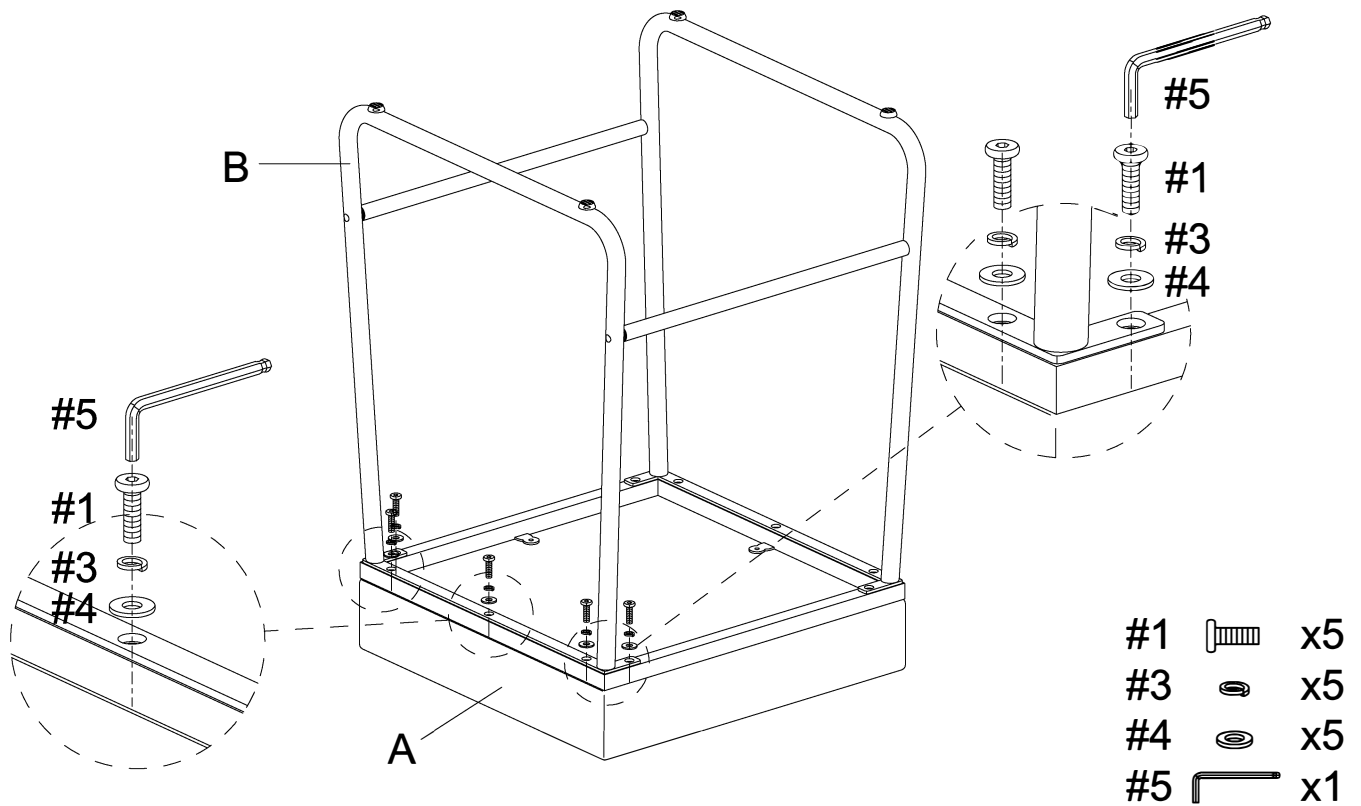

Step 4. Attach leg (part B) to stretchers (part C) using long bolts (part #2) and allen wrench (part #5).

NOTE: Please fully tighten all bolts at this time.

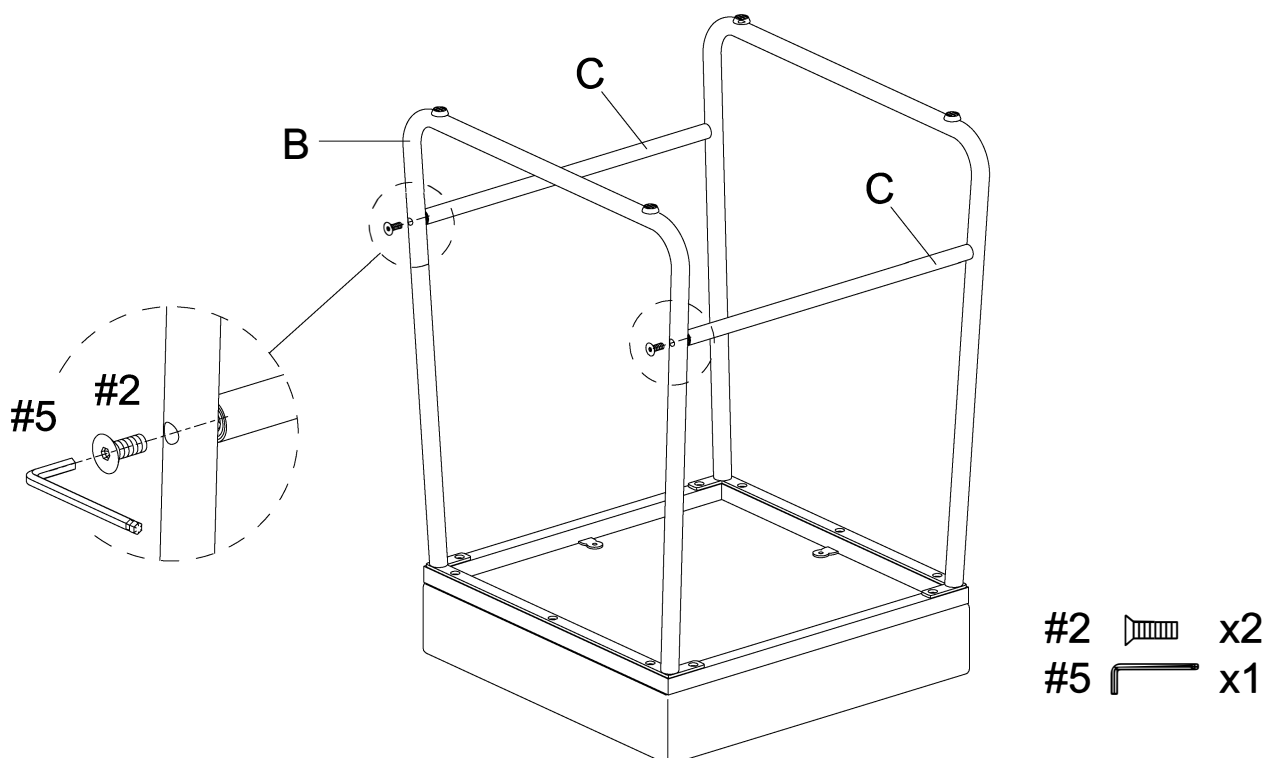

Step 5. Carefully turn unit upright. Repeat steps 1- 4 to assemble remaining stool.

NOTE: It is important to adjust levelers once fully assembled and upright. Extend adjustable leveler until it's firmly in contact with the floor. If relocating, adjust leveler as needed until it's firmly in contact with the floor in new location.

