

# Installation & Assembly



10 : 00

---

estimated  
assembly time



2 or more

---

people required

Ok, let's  
get started!



- Put on mood music!
- To prevent damage to product, use the clean side of package carton or rug as working surface.
- In the event of missing or damaged parts, delivery problems etc., please reach out to our team.  
We will be happy to fix the problem!

# care guide

- Clean regularly with a soft and dry cloth.
- To protect finish, avoid use of abrasive cleaners.
- Wipe up spills immediately. Please!



# product parts



(A)  
Table Top  
x1



(B)  
Shelf  
x1

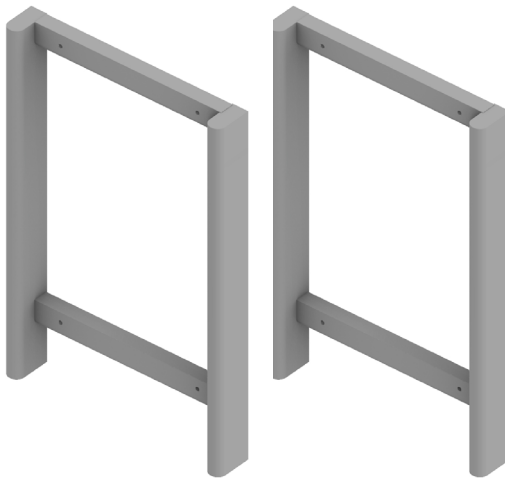

(C1, C2)  
Legs  
x2

# what's included



(D)- Washer  
(16x6)  
X8



(E)- Lock Washer  
(12x6)  
X8

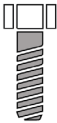

(F)- Bolt  
(30x6)  
X8

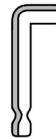

(G)- Ball Allen Key  
(4mm)  
x1

**GS**

Green sticker

**OS**

Orange sticker

## assembly instructions

Friendly Tip: Take a deep breath going in. This may be a tricky part, but nothing too overwhelming. Just follow these steps to the T and the outcome will be worth it!



- ⓘ While assembling the product, tighten the bolts up to 50%. Once all parts are in place, only then fully tighten the bolts.

step 1:

Start by placing the table top (A) upside down on a flat surface.

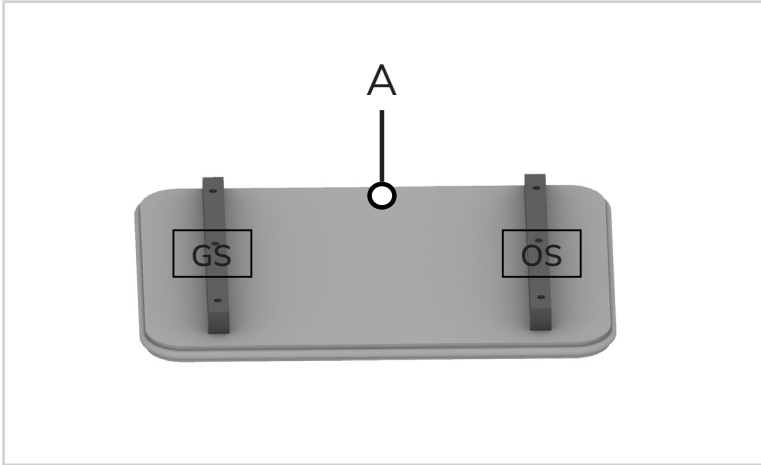

step 2:

Align one of the legs (C1) with the slots on the table top. Ensure the stickers on the legs are similar to the stickers on the table top.

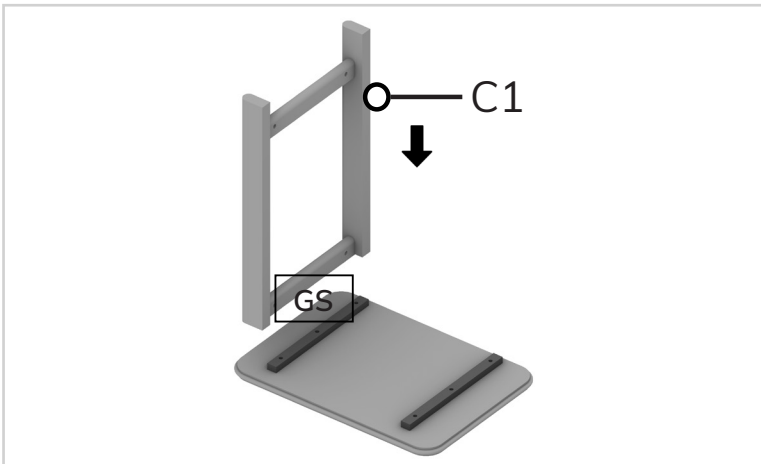

step 3:

Now, fix the leg in place by using washer (D), lock washer (E), and bolts (F) in the given slots. Tighten using an allen key (G).

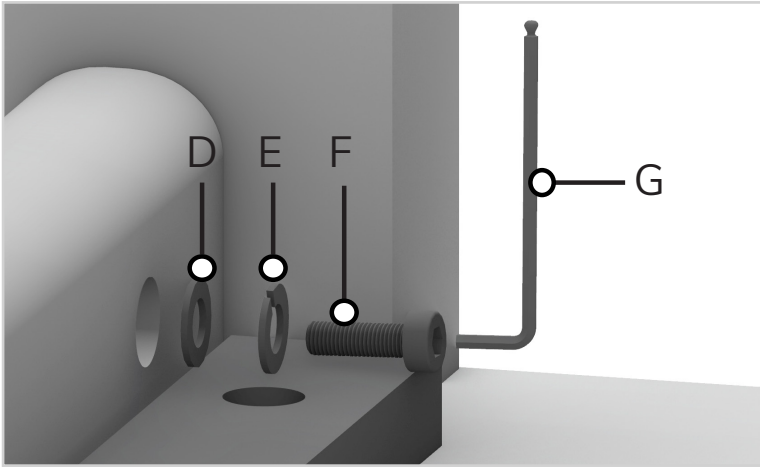

step 4:

Next, place the shelf (B) sideways and align the holes on the shelf (B) to the slots on the table leg (C1). Fix them in place by inserting washer (D), lock washer (E), and bolts (F) in the given slots. Tighten all the bolts up to 50% using allen key (G).

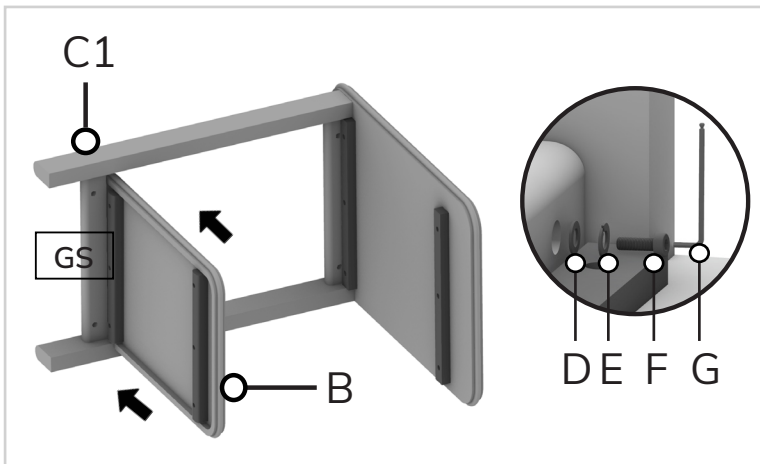

## step 5:

When done, insert the leg (C2) on the right side of the table. Ensure the slots on the leg are aligned with the slots on the table top (A) & shelf (B). Fix it in place by inserting washer (D), lock washer (E), and bolts (F) in the given slots. Tighten all the bolts fully using allen key (G).

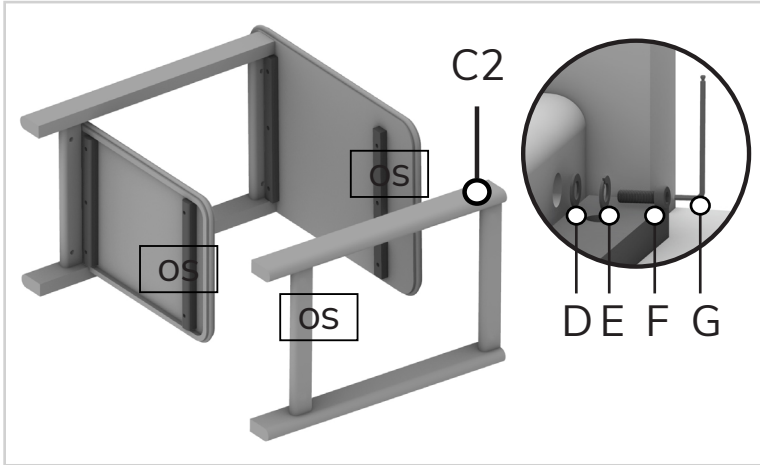

## step 6:

Turn the table upright, as shown in the image.

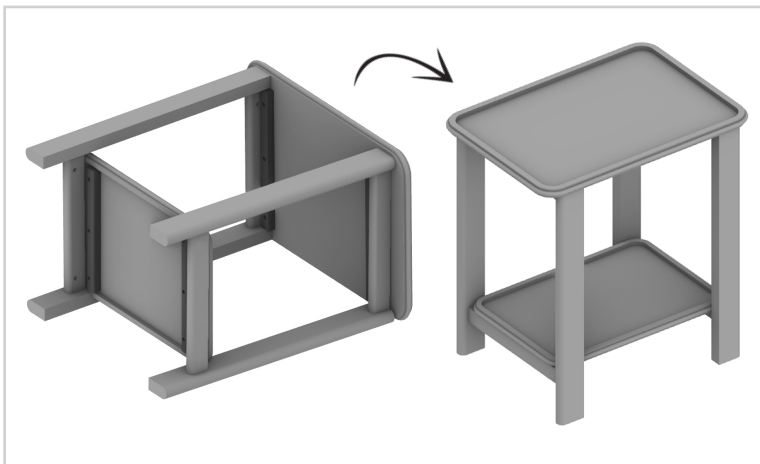

step 7:

If required, adjust the levellers according to the floor.

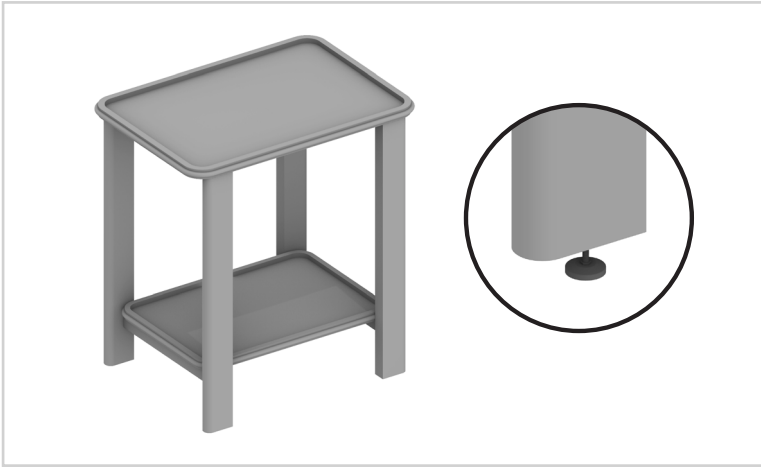



---

**Voila! Your end table is now assembled and secure!**