



## Parts and Damage Replacement Procedure

1. Please inspect your purchase immediately.
2. This procedure covers product purchased from an authorized Roundhill Reseller and was received in its originally sealed carton.
3. If you find a part missing or damaged, you have a 30-day window in which to order a replacement part from the date on your purchase receipt.
4. You have 3 ways to do this. You will need a copy of your purchase receipt.
  - a. By Fax: Fax the parts order form below and along with your receipt to 614-878-7918
  - b. By Email: Email the order form and along with your receipt to: [parts@roundhillfurniture.com](mailto:parts@roundhillfurniture.com)
  - c. By Mail: Fill out the parts order form below and along with a copy of your receipt send it to Roundhill furniture parts department 3640 Zane Trace Drive, Columbus OH 43228
5. Once this order is sent in, you will be notified if the part(s) you are requesting can or cannot be shipped within 7-10 business days.

**A COPY OF YOUR PURCHASE RECEIPT OR INVOICE MUST BE ATTACHED TO THIS ORDER FORM.  
NO ORDERS WILL BE PROCESSED WITHOUT PROOF OF PURCHASE.**

NAME: \_\_\_\_\_

ADDRESS: \_\_\_\_\_ (No Post Office Boxes)

CITY: \_\_\_\_\_ STATE: \_\_\_\_\_ ZIP: \_\_\_\_\_

PHONE: \_\_\_\_\_ FAX: \_\_\_\_\_

EMAIL: \_\_\_\_\_

**REASON FOR REPLACEMENT/PLEASE CHECK APPROPRIATE BOX.**

- Damaged /scratched, cracked, broken, crushed, etc.
- Mechanical malfunction/ drawer glides, swivel mechanisms, lid stays, etc.
- Missing pieces
- Unfinished surface
- Wrong color
- Other

IF MORE THAN ONE MODEL NUMBER IS LISTED ABOVE, PLEASE SPECIFY THE EXACT MODEL NUMBER OF YOUR ITEM IN THE SPACE PROVIDED BELOW.

Model Number	Part Letter Code	Quantity

# ITEM NO. B234 NIGHT STAND

## ASSEMBLY INSTRUCTION





MODEL : B234N

DESCRIPTION : NIGHT STAND

Thank you for purchasing this quality product. Be sure to check all packing material carefully for small Hardware which may have come loose inside the carton during shipment. Identify and count all Hardware and compare with the Hardware List below.

Component List		
No	Descriptions	Qty
A	Feet	4

STEP 1 : Rotate the carton box and open it from below. Then, take out assembly instructions sheet, hardware pack and feet packaging from bottom of night stand which marked with the rope.

Hardware List		
No	Descriptions	Qty
1	JCBC M6 x 60mm 	4
2	Spring Washer Ø1/4" 	4
3	Flat Washer Ø1/4" x 20mm 	4
4	L Key M4 x 100mm 	1

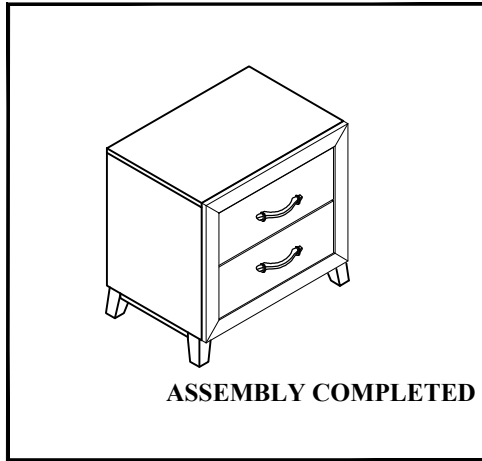
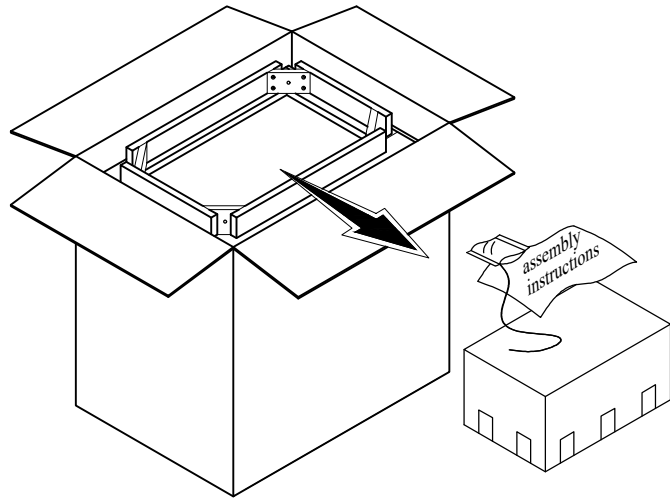

STEP 2 : Align & fasten Feet (A) to Night Stand. Fasten the feet using JCBC (1), Flat Washer (3) and Spring Washer (2) until fully tighten with L Key M4 (4).

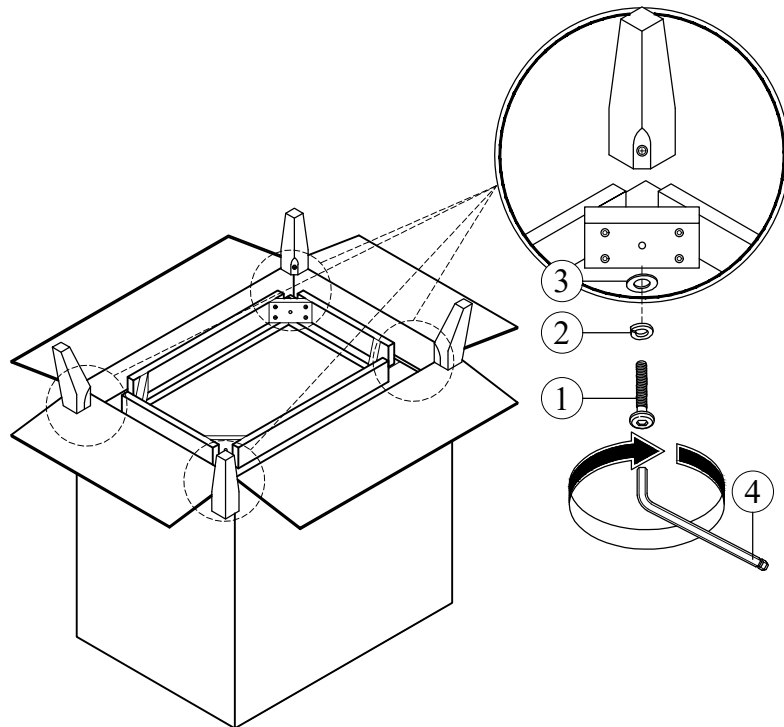

# ITEM NO. B234 NIGHT STAND

## ASSEMBLY INSTRUCTION

MODEL : B234N

DESCRIPTION : NIGHT STAND

Thank you for purchasing this quality product. Be sure to check all packing material carefully for small Hardware which may have come loose inside the carton during shipment. Identify and count all Hardware and compare with the Hardware List below.

**STEP 1**  
Pull out the Drawer of case good.

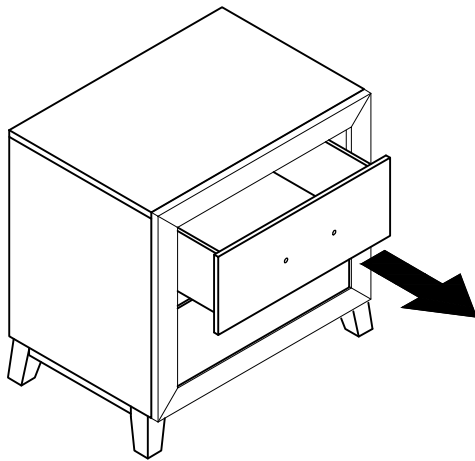

**STEP 2**  
Use Screwdriver to remove the screw & handle

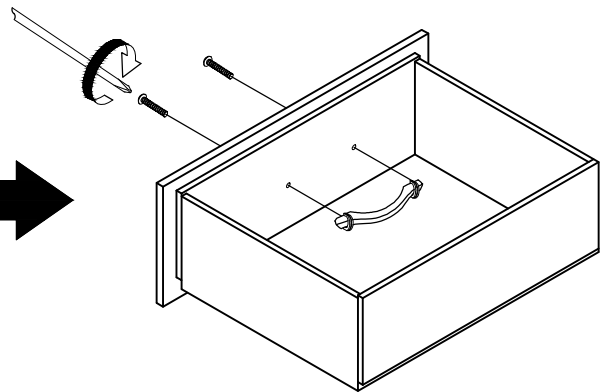

**STEP 4**  
Repeat the same step to the others drawer

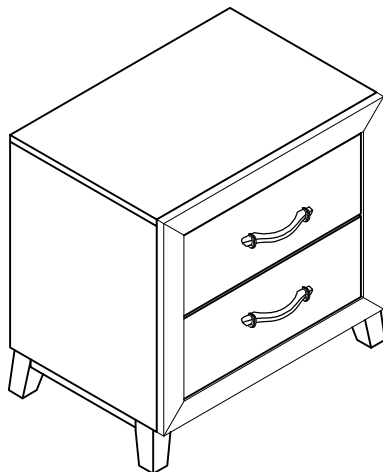

**STEP 3**  
Then reverse the handle and screw and assembly to front of the drawer

