

ASSEMBLY INSTRUCTION

ITEM: N715P237376

DINING TABLE

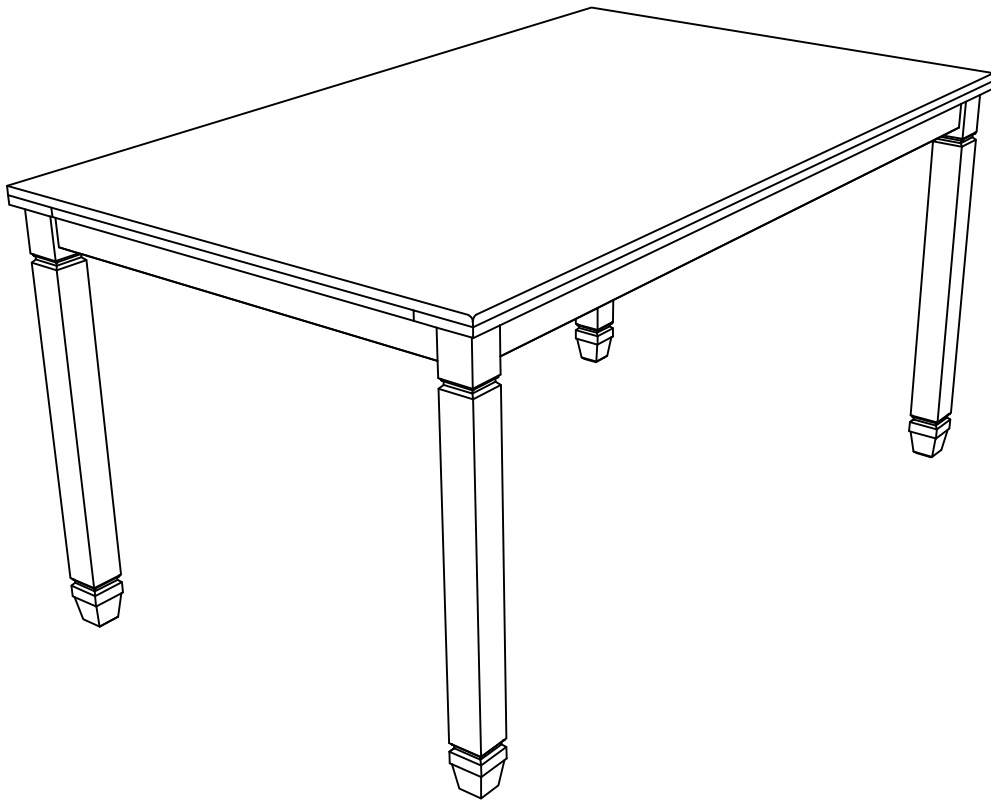

IMPORTANT NOTE :

Please read these INSTRUCTION fully before starting assembly:

1. Place all wooden parts on a clean and smooth surface such as a rug or carpet to avoid scratching the parts.
2. Kindly follow the assembly INSTRUCTION step by step.
3. Do not tighten all screws and bolts until the table is fully assembled.
4. Unscrew the protective plastique supports from the metal insert of the table legs before assembly.
5. Parts of the assembly will be easier with 2 people.

Care and maintenance:

Only clean using a damp cloth and mild detergent, do no use bleach or abrasive cleaners.

A

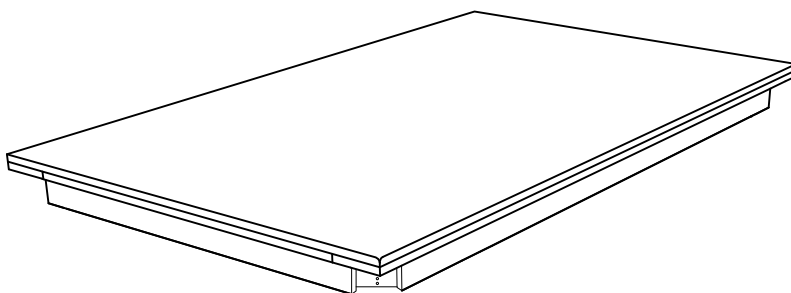

B

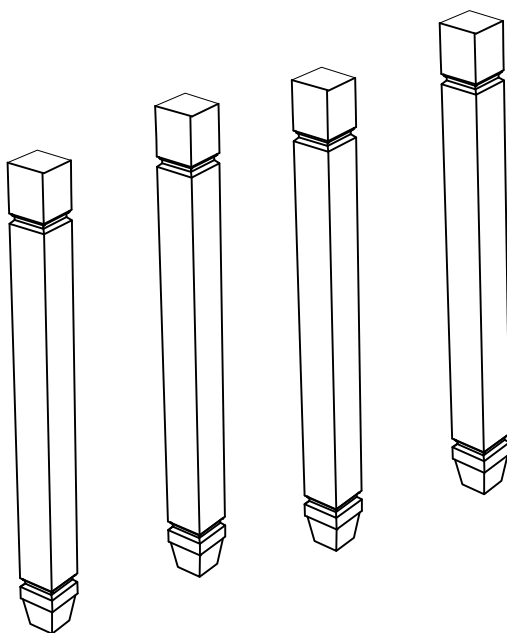

PART AND HARDWARE LIST

Part List For One

Hardware List For One

Ⓐ

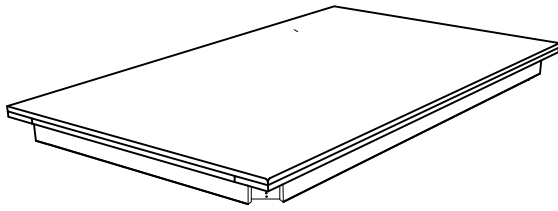
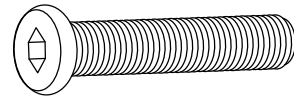

TABLE TOP (1 pc)

①



Ø5/16" x 60mm

BOLT (8 pcs)

Ⓑ

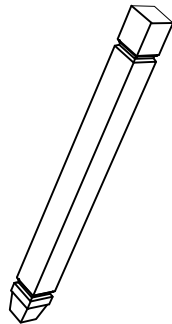

LEG (4 pcs)

②

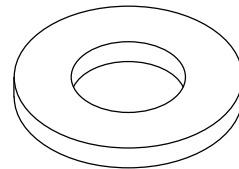

Ø5/16" x 19mm

FLAT WASHER (8 pcs)

③

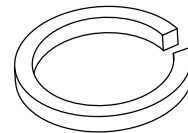

Ø5/16" x 13mm

SPRING WASHER (8 pcs)

④

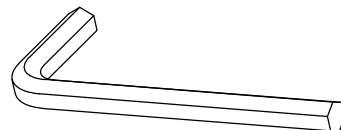

M4 x 60mm

ALLEN WRENCH (1 pc)

ASSEMBLY INSTRUCTION

ITEM: N715P237376

STEP 1:

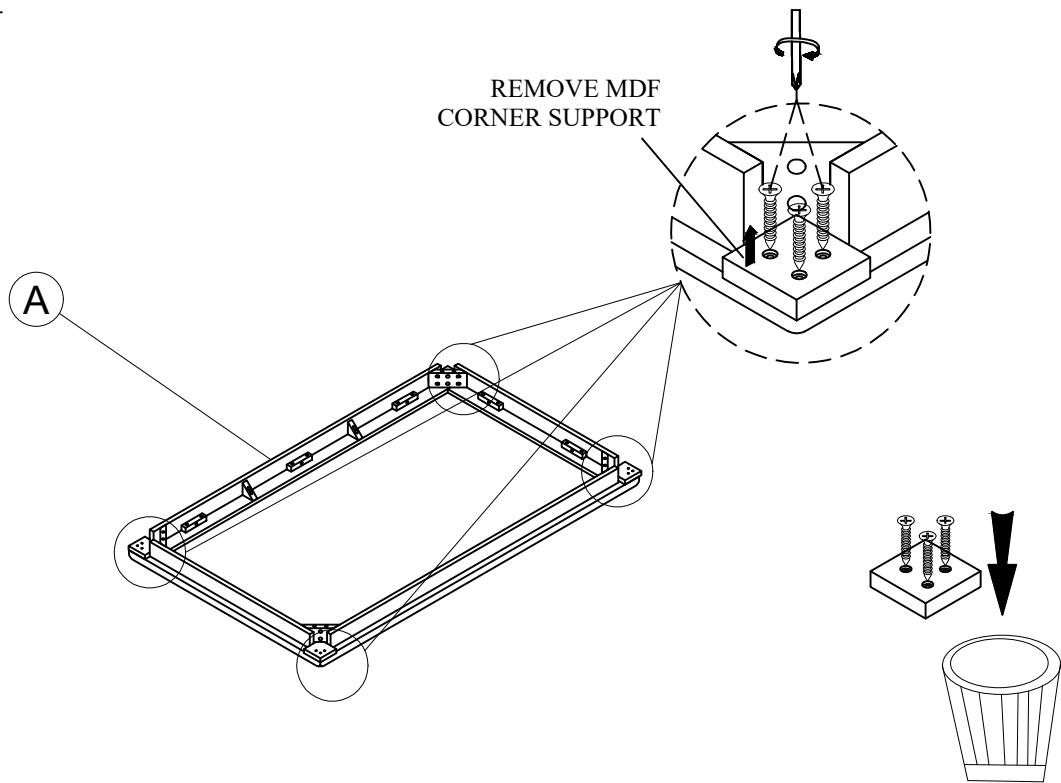

STEP 2:

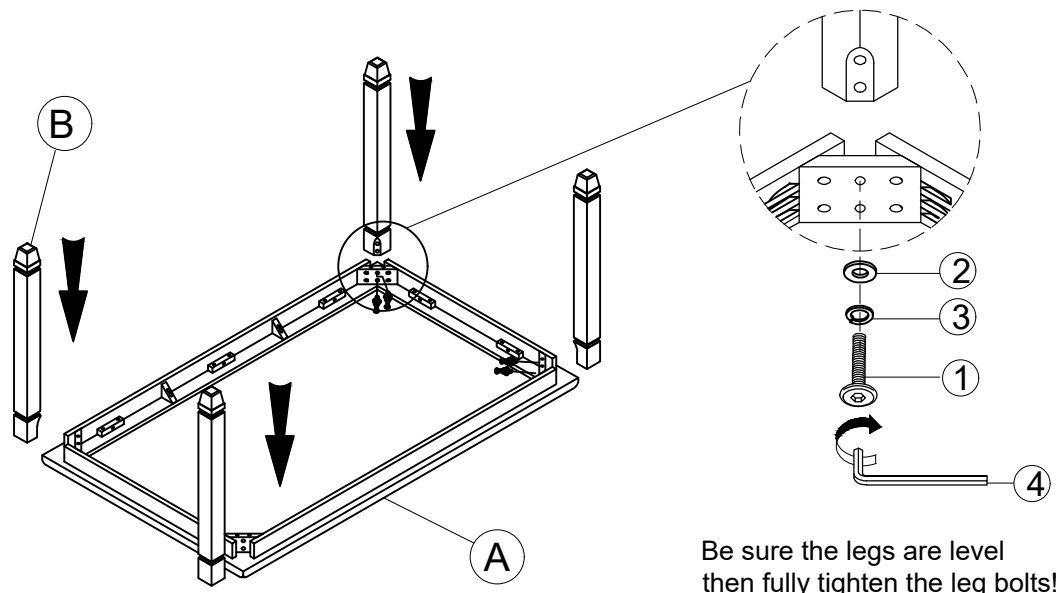

Bolts
5/16" x 60mm

Flat Washer
5/16" x 19mm

Spring Washer
5/16" x 13mm

Allen Wrench
M4 x 60mm

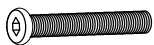

① x 8



② x 8



③ x 8



④ x 1

MADE IN VIETNAM

PAGE 4 OF 5

ASSEMBLY INSTRUCTION

ITEM: N715P237376

COMPLETE

