













Installation Diagram

Item No.:	BJ003
Specification name:	C Shaped End Table (40CM/15.7 INCH)

Parts List

Number	Name	Diagram	Specification	Quantity
1	Left frame		581.5*390*20MM	1
2	Right frame		581.5*390*20MM	1
3	Inner box		400*400*57MM	1
4	Bottom plate		350*375*34MM	1
5	Panel block		120*20*20MM	1

Hardware List

Number	Name	Diagram	Specification	Quantity
A	Open end wrench		Opening 14MM	1
B	Threaded caster with brake		φ25MM, total height 43MM	2
C	Threaded casters without brakes		φ25MM, total height 43MM	2
D	Hexagon socket screw		M6*25MM	4
E	Hexagon socket screw		M6*25MM	4
F	Flat gasket		M6*13MM	8
G	Allen wrench		M4* 100*40MM	1

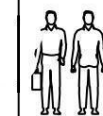
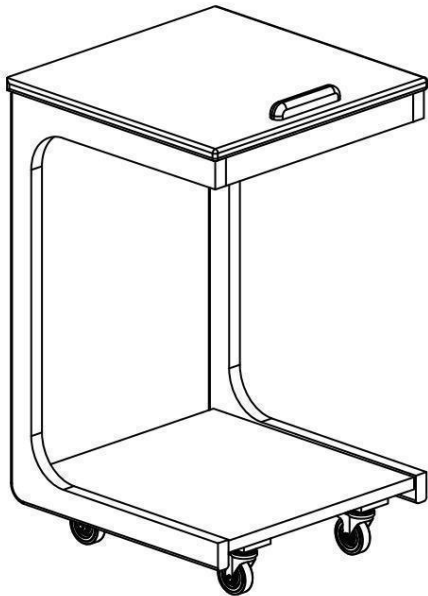

Inspectors

QC 02

Step 1

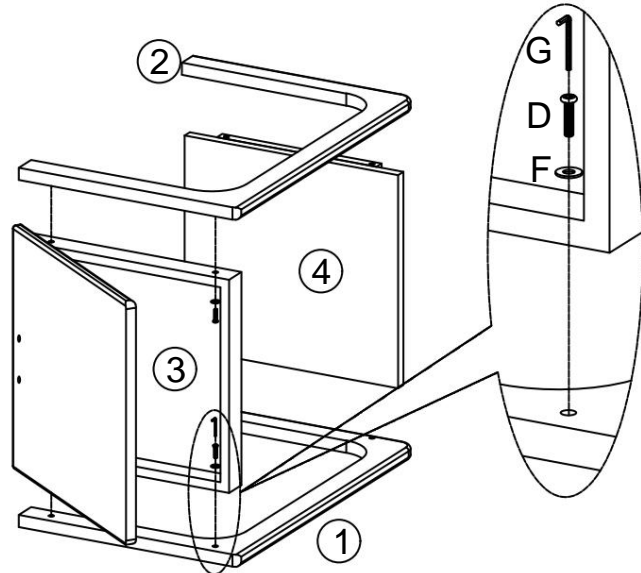

Note: After unpacking, please first check the instruction manual to see if the number of assembled parts as shown is correct. Then assemble as shown, align No. 1/2 components with the holes on the end faces of No. 3/4 components and assemble 3 components first. No. parts position, and then use hardware D, F, G to fix it.

Step 2

Note: The length of the assembly screw in steps 1 and 2 is different!!!

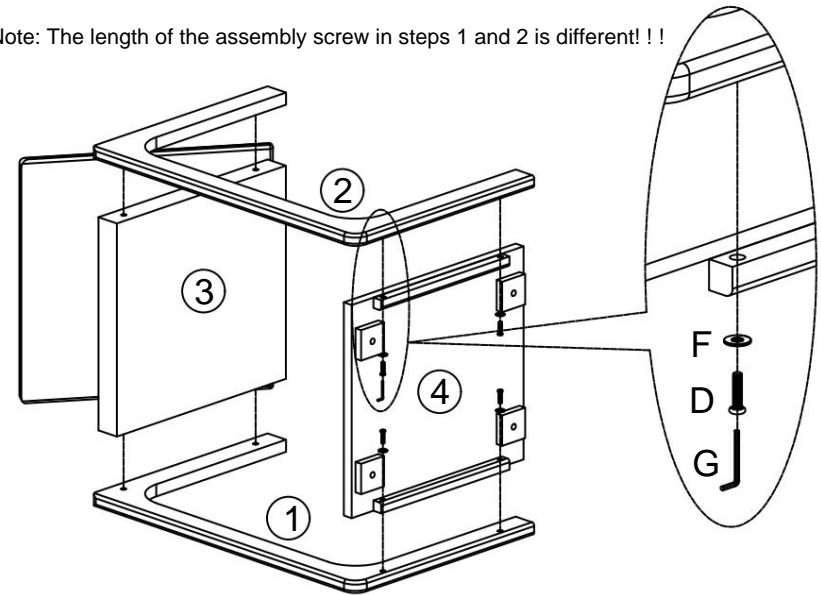

Assemble as shown in the picture. After completing step 1, assemble component No. 4 and fix it with hardware E, F, and G.

Step 3

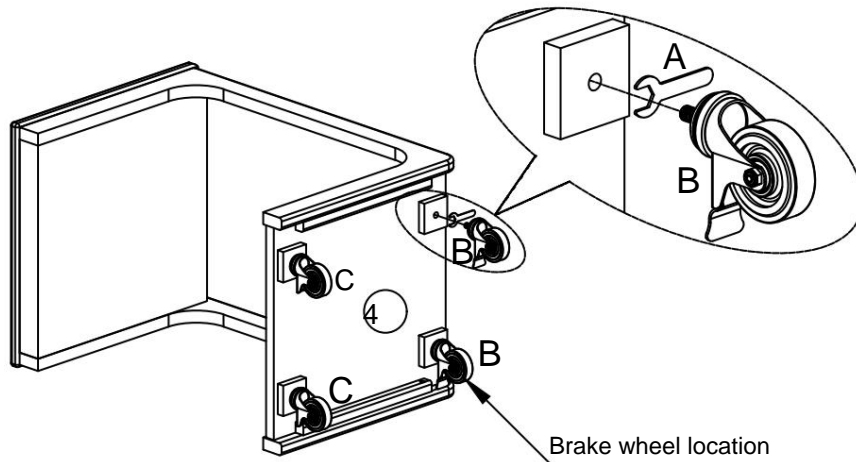

Assemble as shown in the figure, use hardware A to rotate hardware B and C clockwise to assemble them to the bottom plate of component No. 4, and pay attention to the position of the hardware casters!

Step 4

Assembly completed

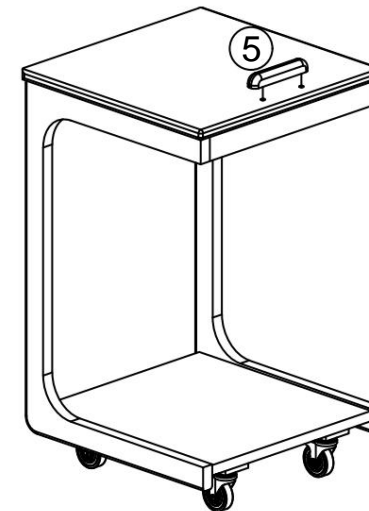

Assemble as shown in the figure, install part 5 on the panel, and the assembly is complete.