

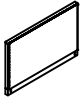

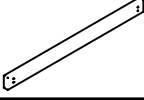





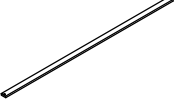

T

PART LIST			
A	Headboard		1PC
B	Footboard		1PC
C	Legs		4PCS
D	Right Side rail		1PC
E	Left Side rail		1PC
F	Slats		12PCS

HARDWARE LIST			
1	Bolt $\text{Ø}5/16'' \times 1-3/16''$		8PCS
2	Screw M4 x 1-3/16''		24PCS
3	Lock Washer $\text{Ø}5/16''$		8PCS
4	Flat Washer $\text{Ø}5/16''$		8PCS
5	Allen Wrench M4		1PC
6	Anti Slip Sheet		4PCS

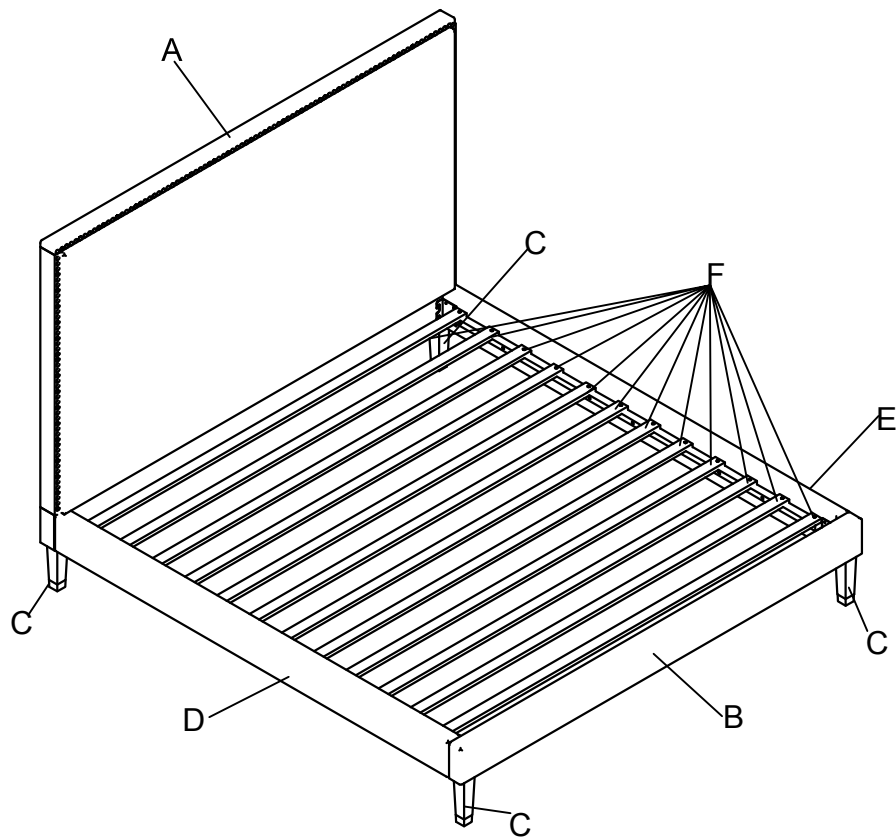

STEP 1

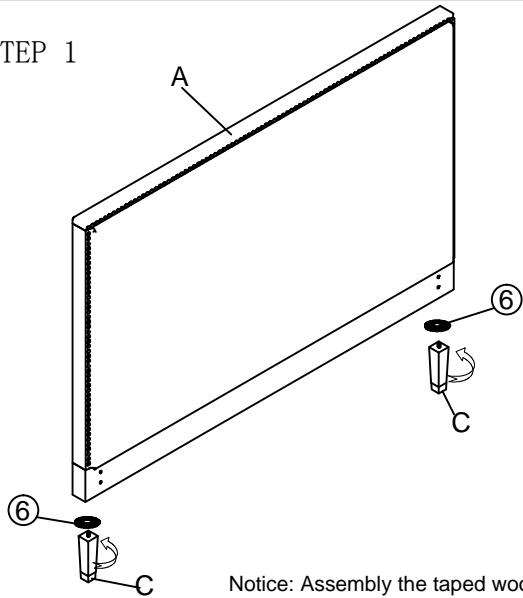

STEP 2

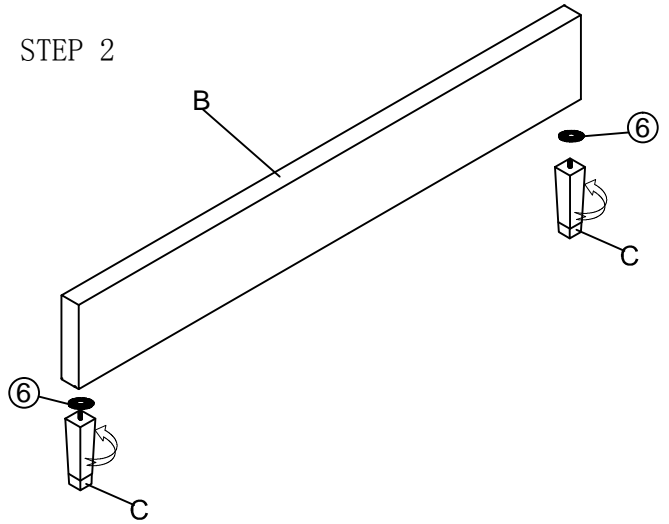

Notice: Assemble the taped wood leg with plastic ring into Headboard/Footboard bottom. Be tighten and keep the wood leg direction aline with headboard/Footboard. See illustration and Simple drawing.

STEP 3

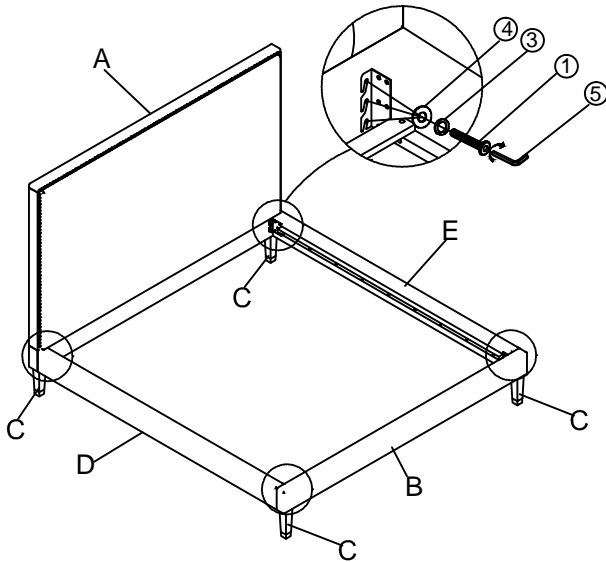

STEP 4

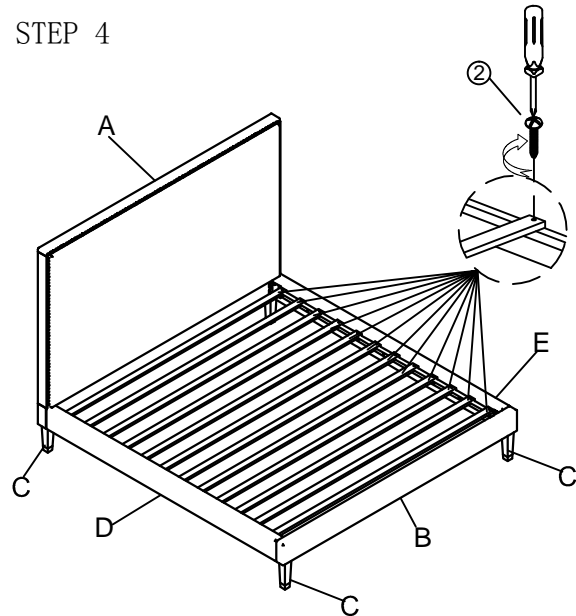

STEP 5

