

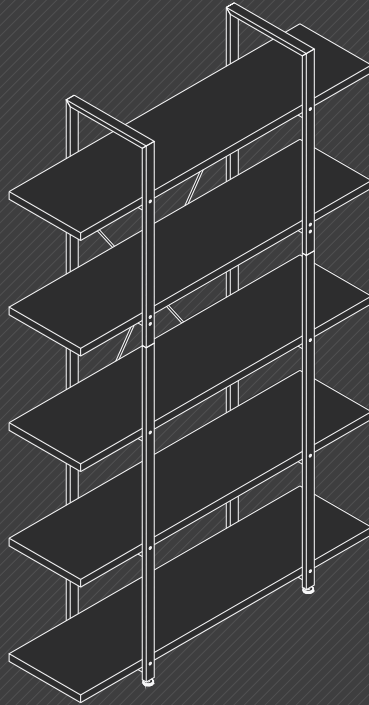

# 5-Tier Industrial Bookshelf



**USER MANUAL**



# Contents

| TOPIC     |  | PAGE         |
|-----------|--|--------------|
| <b>01</b> | <b>SAFETY INSTRUCTIONS</b>             | <b>01-01</b> |
|           | 1-1 Thank You For Choosing Our Product | 01           |
|           | 1-2 Precautions                        | 01           |
| <b>02</b> | <b>INSTALLING MODULES</b>              | <b>02-11</b> |
|           | 2-1 Disassembly Diagram                | 02           |
|           | 2-2 Parts List                         | 03           |
|           | 2-3 Assembly Instructions              | 04-11        |
| <b>03</b> | <b>CUSTOMER SERVICE</b>                | <b>12</b>    |
|           | 3-1 30-Day Return Policy               | 12           |
|           | 3-2 1-Year Warranty                    | 12           |
|           | 3-3 Quick Response Within 24 Hours     | 12           |
| <b>04</b> | <b>PROBLEMS YOU MAY ENCOUNTER</b>      | <b>13</b>    |
|           | 4-1 Problems You May Encounter         | 13           |

# Safety Instructions

## Thank You For Choosing Our Product

Before assembly, please read this USER MANUAL first, and check according to Parts List to make sure all parts are included. Feel free to contact us if you have any concerns or questions about your product, we are always ready to help. Your satisfaction is our first priority!

## Precautions

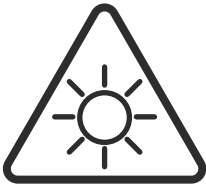

- Avoid long-term direct sunlight exposure.



- Keep away from sharp objects.

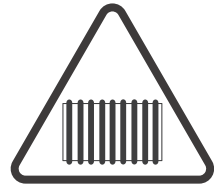

- Keep away from heat.



- Keep infants/children away from assembly parts to avoid choking and suffocation.



- Keep away from corrosive substances.

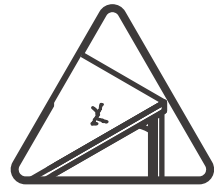

- Pay attention to avoid over-tightening fasteners, or they may induce cracking within the board.



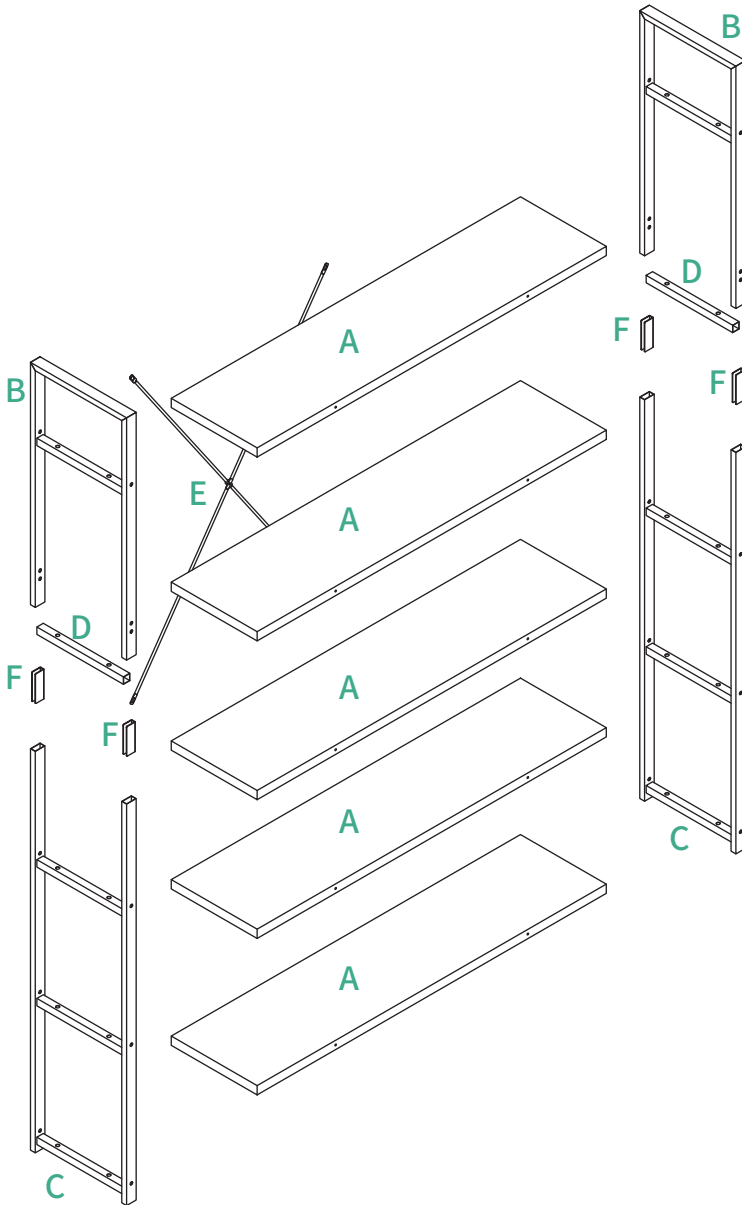



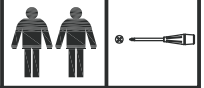

# Disassembly Diagram

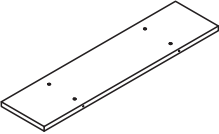
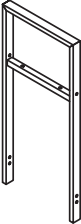
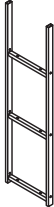
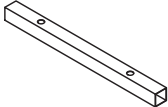

# Parts List

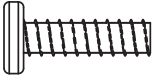
For ease and safety, we recommend two people for assembly.

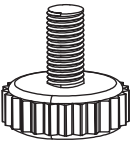
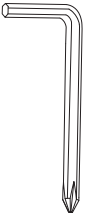

|  |   |   |   |
|--|---|---|---|
| <p><b>A</b><br/>x5</p>                                     | <p><b>B</b><br/>x2</p>                                     | <p><b>C</b><br/>x2</p>                                     | <p><b>D</b><br/>x2</p>    |
| <p><b>E</b><br/>x1</p>                                    | <p><b>F</b><br/>x4</p>                                     |   |   |
| <p><b>1</b><br/>x23</p>  <p><b>M6×50</b>    3 Spares</p> | <p><b>2</b><br/>x27</p>  <p><b>M6×25</b>    3 Spares</p> | <p><b>3</b><br/>x14</p>  <p><b>M6×12</b>    2 Spares</p> | <p><b>4</b><br/>x2</p> <p>a </p> <p>b </p> <p>c </p> |
| <p><b>5</b><br/>x5</p>  <p>1 Spare</p>                  | <p><b>6</b><br/>x2</p>  <p>1 Spare</p>                   |   |   |

# Assembly Instructions

1

x2

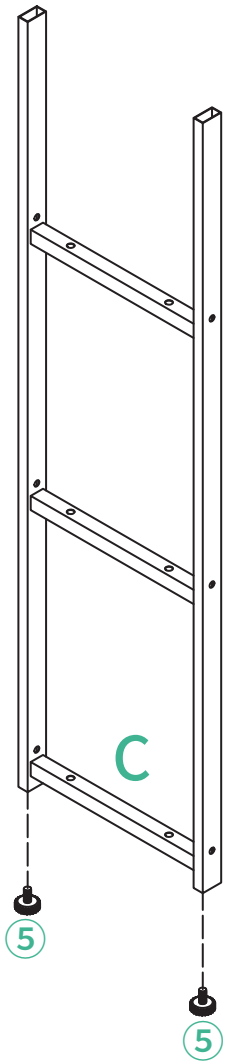
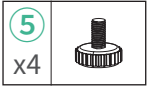
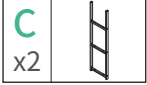

# Assembly Instructions

2

- (1) Ensure the screw holes marked by the red arrow on Part D face upward.
- (2) Insert screw ② into the lower screw hole. (Refer to the enlarged detail.)

x2

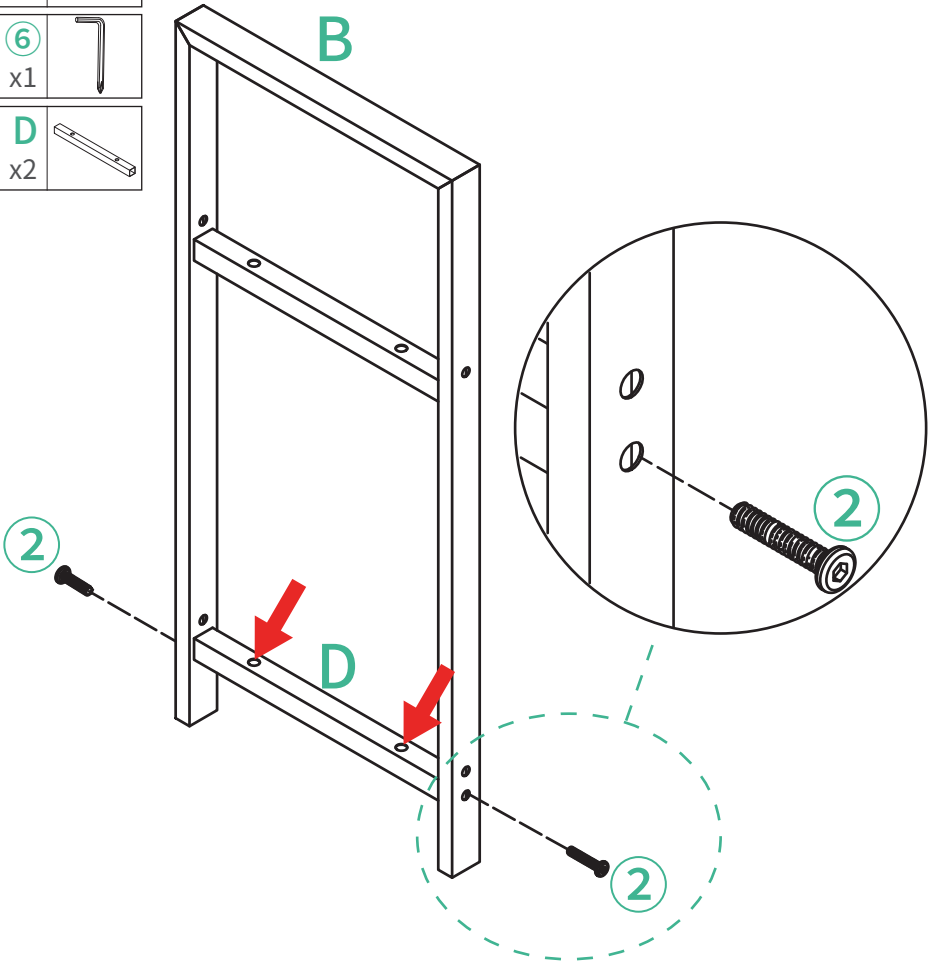
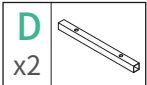
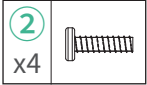

# Assembly Instructions

3

- (1) Refer to the enlarged detail for the correct orientation of Part F's opening.
- (2) Tighten screws ③ only to 50%.

x2

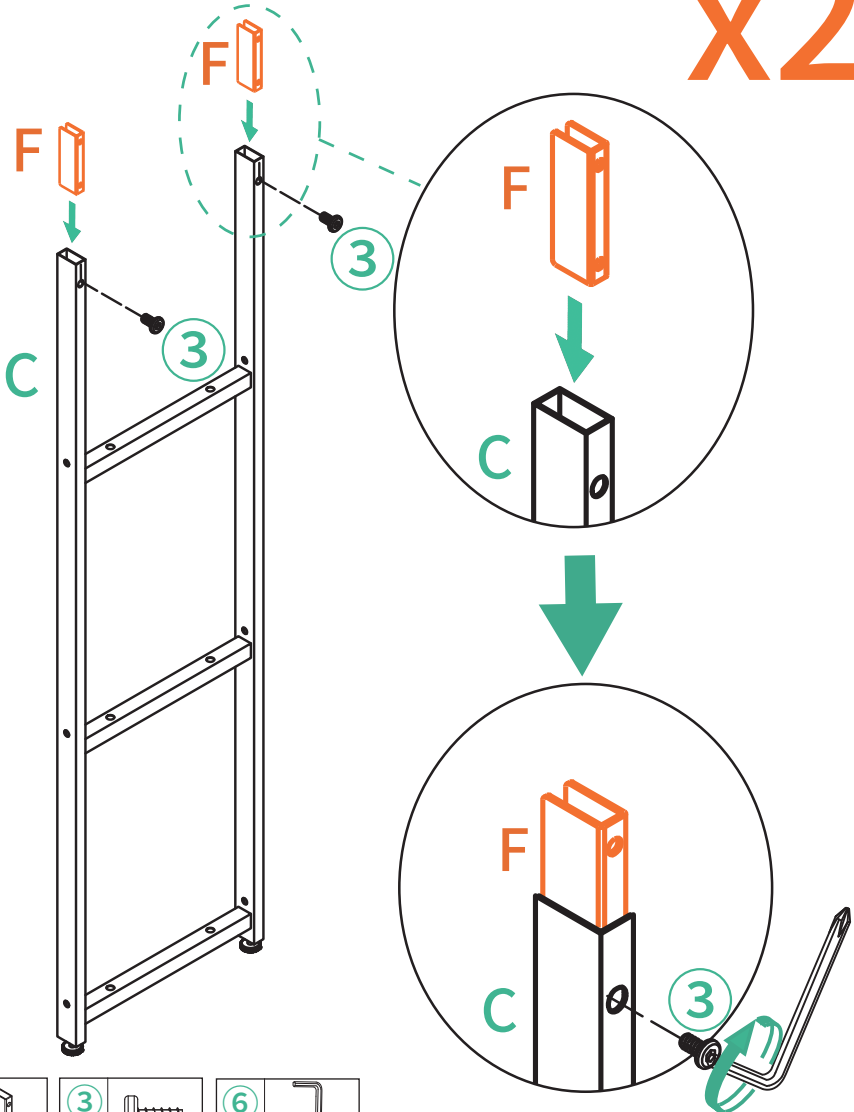

|                |  |                |  |                |  |
|----------------|--|----------------|--|----------------|--|
| <b>F</b><br>x4 |  | <b>③</b><br>x4 |  | <b>⑥</b><br>x1 |  |
|----------------|--|----------------|--|----------------|--|

# Assembly Instructions

4



(1) Ensure the screw holes marked by red arrows on Frame B and C face the same side.

(2) Align Frame B and C, then fully tighten all screws ③ from Steps 3 and 4.

x2

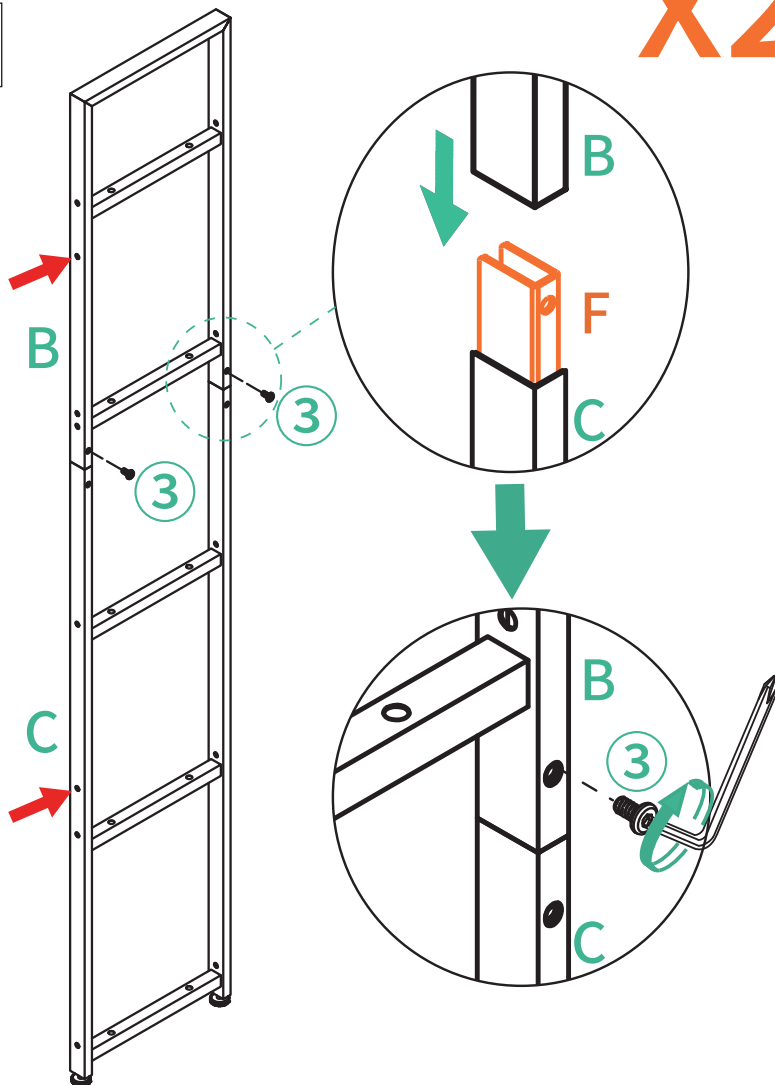



## 6

- (1) First, fully tighten 10 screws ① as shown pre-arrow diagram, then flip the product and fully tighten the remaining 10 screws ①.
- (2) After installing all screws ①, fully tighten all screws ② from Step 5.

### Step 1

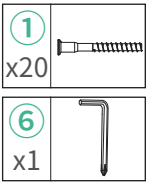
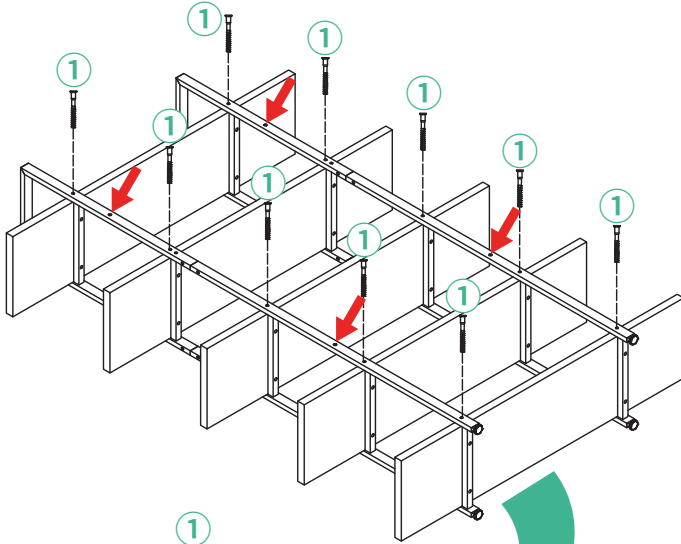

### Step 2

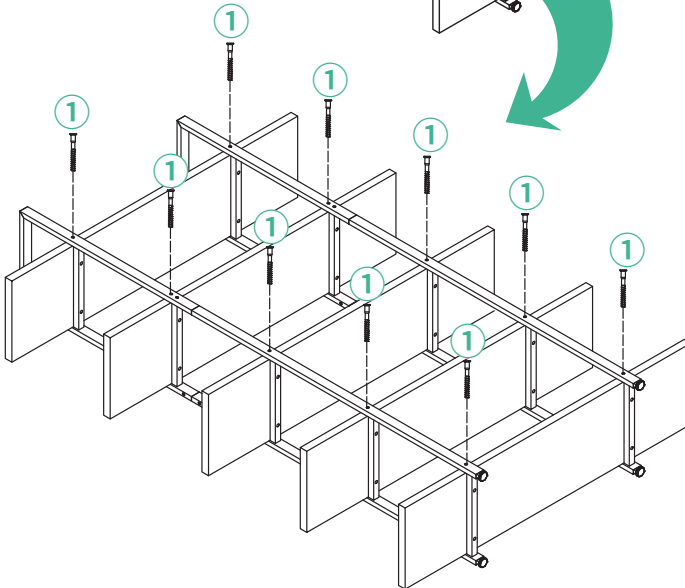

## 7

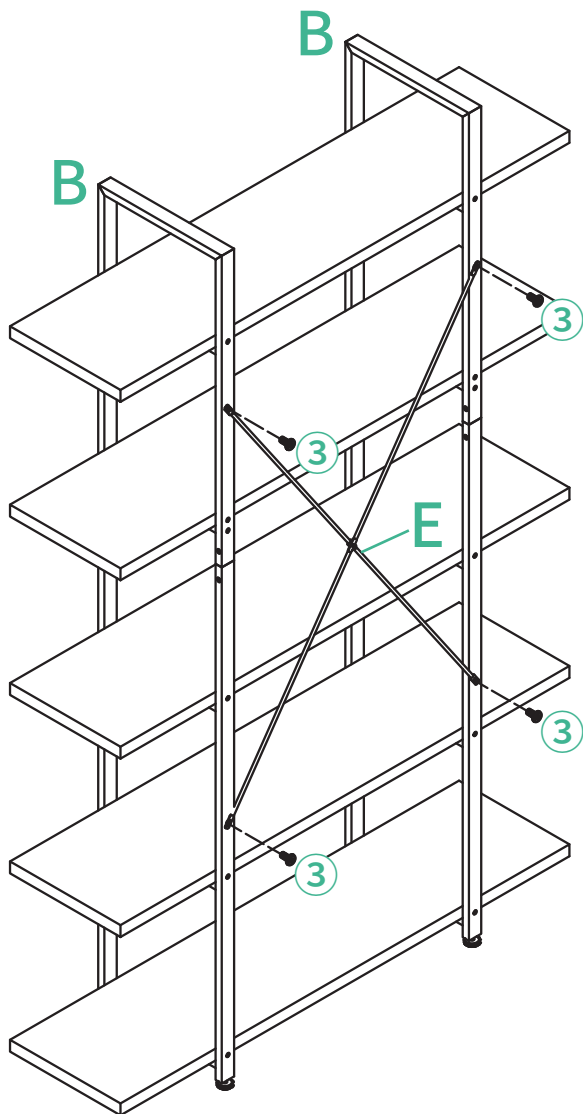

# Assembly Instructions

8

1. Drill a 1/6-inch diameter hole in the wall with a power drill.
  2. Screw plastic anchor c into the hole with a philips head screwdriver/stubby screwdriver until flush with wall.
  3. Secure Part b through Part a into Part c.
- Note: Avoid over-tightening Part b.

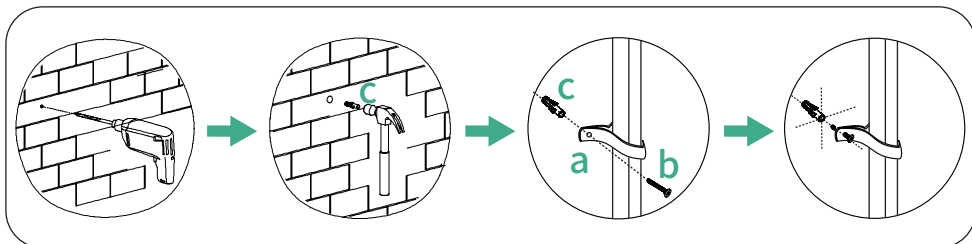

wall

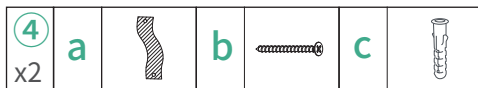
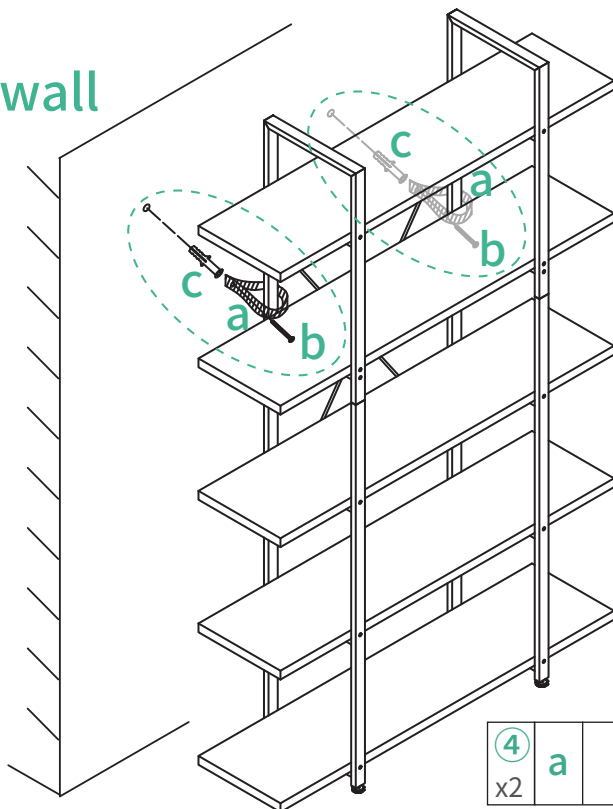



## 30 DAY Return Policy

If you're not completely satisfied with your purchase, please return the merchandise via our Official Customer Support. Unused merchandise can be refunded or exchanged within 30 days of purchase.



## 1-Year Warranty

We guarantee your product is free from defects in product material and workmanship for one (1) year starting from the date of purchase during normal use of household conditions. If your appliance fails to operate properly within our warranty period, we will arrange a new one. Replacement is free and all shipping costs are covered.



## Quick Response within 24 Hours

If you are still unable to resolve the issue you are experiencing, please contact us immediately via our support email. It doesn't matter if the product has been installed or not, our customer support team will respond within 24 hours and assist you quickly and efficiently. The most efficient way to confirm your problem to us is to attach a video, which illustrates your product issues.

## Problems You May Encounter

| PART          | PROBLEM  | SOLUTION   |
|---------------|--|--|
| Whole Product | Parts are missing, defective or having wrong parts in package.             | You can contact us and we will get back to you within 24 hours.<br>Or, you can reach us via after-sales email.   |
|               | Having issue(s) while reading the instruction or completing the assembly.  | You can contact us and we will get back to you within 24 hours.<br>Or, you can reach us via after-sales email.   |
|               | Encountering non-human caused damage during usage.                         | If the product is damaged due to non-human causes, please keep the product and send us photos of it. We will ascertain the cause of the product damage within 48 hours and provide you with a satisfactory solution.       |
| Table Surface | Board Surface is broken, scratched or lack of somescrew holes.             | You can contact us and we will get back to you within 24 hours.<br>Or, you can reach us via after-sales email.   |
|               | The screw holes that on the board and the steel frame don't line up.       | 1. Please tighten the screws on the board by 70%, do not tighten completely.<br>2. Adjusting board and steel frame until the screw holes are lined up, then tighten all the screws.  |
|               | The desk board is uneven or not tight that has gaps after being assembled. | 1. Loosen the screws in the uneven or gap positions; adjust until the desktops are flat and tight, and then tighten the screws.<br>2. If your problem still can't be solved, please feel free to contact us.               |
| Steel Frame   | The steel frame is bent, broken, painted, rusted or damaged.               | You can contact us and we will get back to you within 24 hours.<br>Or, you can reach us via after-sales email.   |
|               | The table is unstable after being assembled.                               | 1. Check if the screws are tightened.<br>2. Read throughout the manual, check are there any parts installed incorrectly or missing assembled.<br>3. If your problem still can't be solved, please feel free to contact us. |
|               | Encountering non-human caused damage during usage.                         | If the product is damaged due to non-human causes, please keep the product and send us photos of it. We will ascertain the cause of the product damage within 48 hours and provide you with a satisfactory solution.       |

We are committed to providing our customers with premium quality products and convenient customer service.

MADE IN CHINA