

# 6,8,10,12,16 CHANNEL MIC/LINE MIXER OWNERS MANUAL



FEATURES OF FRONT PANEL

A. INPUT CHANNEL SECTION .....	1
B. MASTER SECTION .....	2
C. MIXER OUTPUT SECTION .....	3
D. POWER SECTION .....	4
E. FAULT FINDING GUIDE.....	5
F. CAUTIONS ON INSTALLATION .....	5
G. HOW TO OPERATE .....	6
H. INSTALLATIONS .....	7
I. BLOCK DIAGRAM .....	8
J. SPECIFICATION .....	9

## A. INPUT CHANNEL SECTION

### 1. BALANCE INPUT

Electronically Balanced inputs acceptable a standard XLR male connector.

+48V Phantom Power available on each input Mic socket.

And this switch is on Rear Phantom Power.

### 2. LINE INPUT

The unbalanced Mic input is provided for the use of a unbalanced mic and is designed to accept a unbalanced high impedance input signal. (This use for connection Deck, Turntable, Keyboard ect.)

### 3. GAIN CONTROL

Adjusts input sensitivity from -60dB to -20dB with the -20dB pad switch in the out position, and -40dB to 0dB when the -20dB pad switch is pushed.

### 4. HIGH

Control the high frequency tone of each channel, Always set this control to the 12 o'clock position, but you can control the high frequency tone according to the speaker, the conditions of listening position and listener's taste, Clockwise rotation of the control increases level.

### 5. MID

This has a function which controls the middle frequency tone of each channel. Always set this control to the 12 o'clock position, but you can control the middle frequency tone according to the speaker, the conditions of listening position and listener's taste. Clockwise rotation of the control increases the level, and vice verse.

### 6. LOW

Control the low frequency tone of each channel. Always set this control to the 12 o'clock position, but you can control the middle frequency tone according to the speaker, the conditions of listening position and listener's state. Clock wise rotation of the control increase the level.

### 7. AUX SEND

Use this control to set the level of signal from external stereo source and the main signal control is recontrolled by STEREO or MONO section.

### 8. EFF

Use this control when you want to get effect sound by adjustment of input signal. when you don't use external source, digital delay will be working which installed inside.

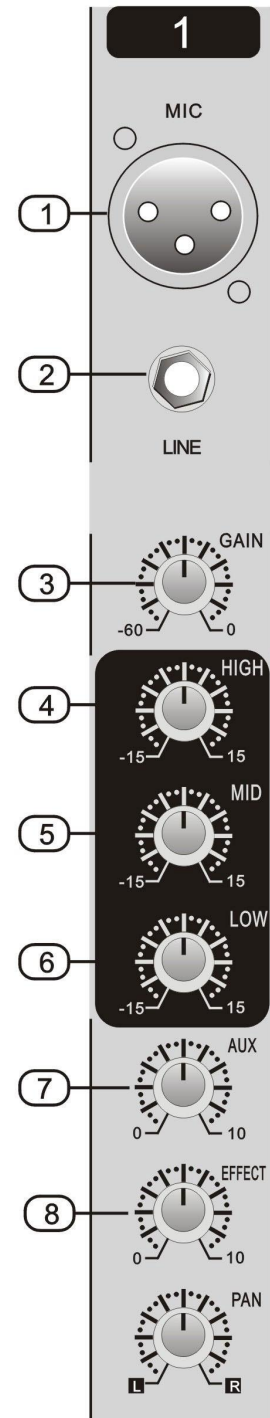

## 9. PAN

The pan control sends continuously variable amounts of the post fader signal to either the left or right main busses. In the center position equal amounts of signal are sent to the left and right busses.

## 10. PFL

You can monitor the signal of the only channel which PFL switch is turned "ON" using by headphone in useful. When PFL switch turned on, other channels ofr cut off automatically.

## 11. PEAK (PEAK LEVEL INDICATOR)

A red LED indicates a signal level at the insert return point, Pre master fader. It illuminates at approximately 5dB below clipping.

## 12. CHANNEL FADER

This is function to adjust the volume of signal connection into each channel and adjust the volume of output, together with master fader. Normal operation is at the "0" mark, providing 4dB of gain above that point, if required.

## B. MASTER SECTION

## 13. EFFECT LEVEL

Using by this control, you can adjust signal level of echo repeat & exterior effect.

## 14. OUTPUT MAIN FADER (LEFT/RIGHT)

This is a master fader for adjustment for volume of left/right output. Unity gain is the top their travel.

## 15. REPEA

This is used for adjusting frequency of echo repeat, since too echo repeat may cause a howl, please adjust frequency properly.

## 16. DELAY

This is used for adjusting the fine interval of echo repeat.

## 17. EFFECT SEND

This is used for adjusting volume of echo sound, when sending echo sound to SEND jack in EFFECTS panel.

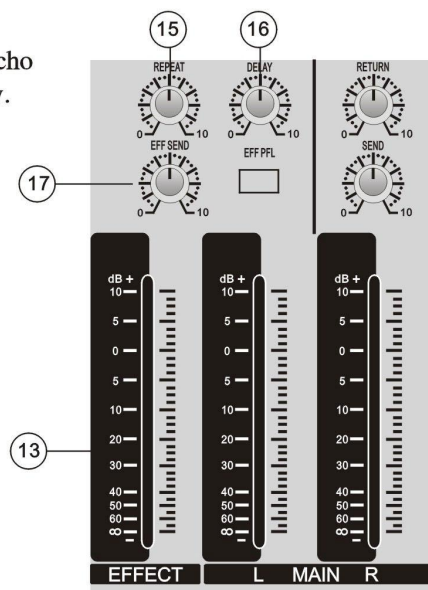
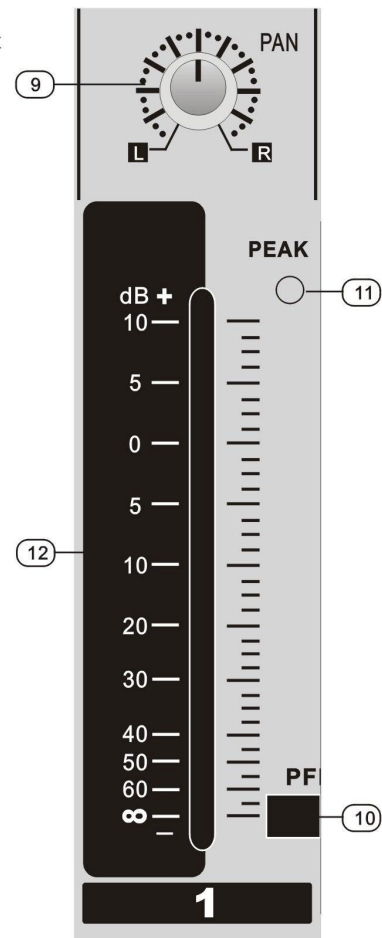

### 18. POWER LED

The POWER LED will be turned on when start working.

### 19. OUTPUTS LEVEL INDICATOR

This is level meter which shows output levels of left & right channel condition on the way of operation, therefore, you can see output condition thru this master level indication.

### 20. +48V

The LED will be turned on when phantom power start working.

### 21. MP3 LEVEL

Level control of the MP3 input signal

### 22. EFX SEND

When you use STEREO board, you can adjust the sound volume of all kinds of effector outside.

### 23. EFX RET

Controls the level of EFX Inputs signal.

### 24. PHANTOM(+48V)

Depressing this switch applies 48V DC across all microphone input channels connectors for remote powering of condenser microphones.

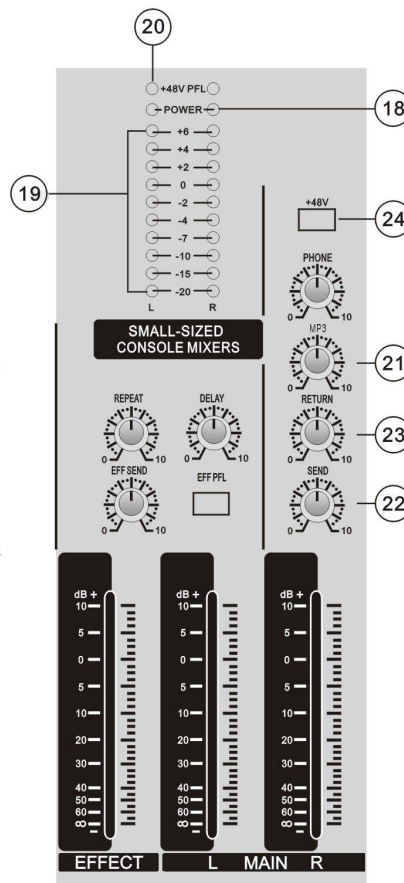

## C. MIXER OUTPUT SECTION

### 25. STEREO OUTPUT JACK (LEFT / RIGHT)

In this pequot, the final confirmed sound can be send to main amplifier through XLR & 1/4 jack.

### 26. STEREO AUX RETURNS & SENDS

This can be used to connect all kindsof effects from outside.

### 27. RECORD PIN JACK

This jack is to be connected with cassette deck when recording the mixed output.

### 28. MP3 & USB status display

MP3 display and control, can connect computer

### 29. PHONES JACK

This is used for monitoring the master signal and individually monitoring each channel with PFL, L/R & G1-2.

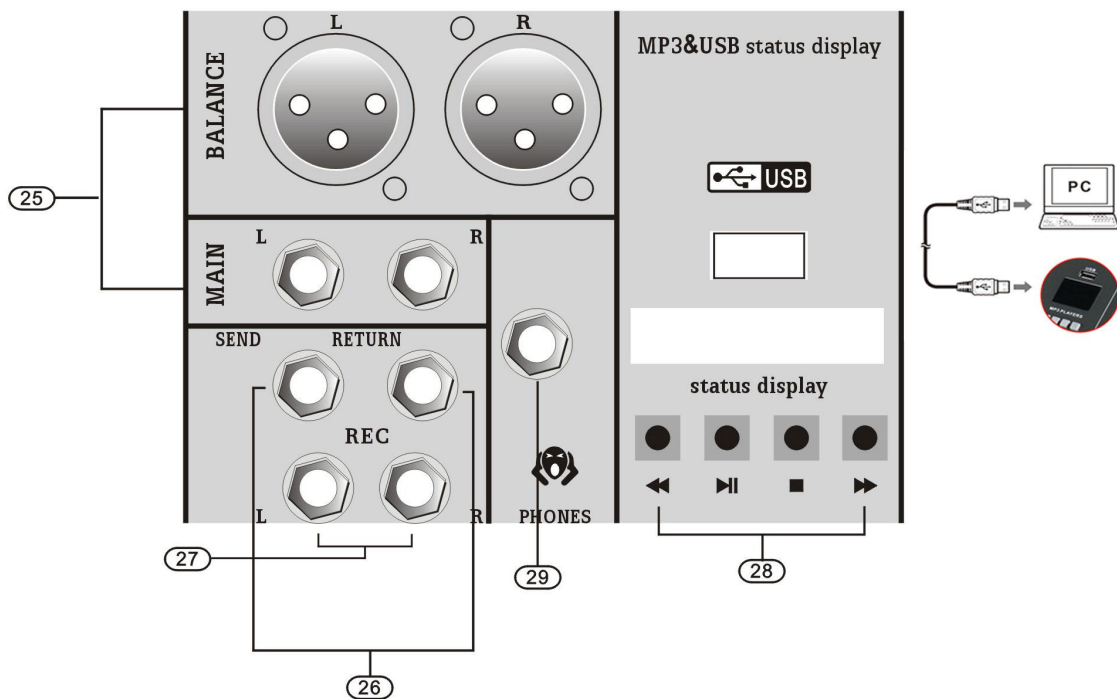

## D. POWER SECTION

### 30. POWER SWITCH

Push marked, when you want to operate. The LED will be turned on when working

### 31. POWER JACK

This is out of connect the power supply jack.

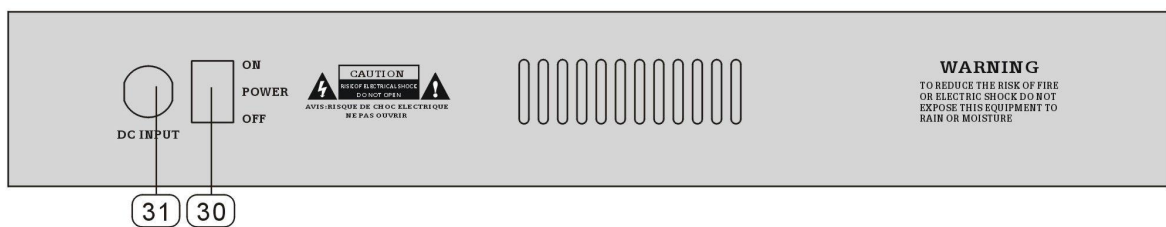

## *E. FAULT FINDING GUIDE*

Repairing a sound mixing console requires specialist, but basic fault finding is within the scope of any user if a few basic rules followed.

- Get to know the block Diagram of your console.
- get to know what each component in the system is supposed to do.
- Learn where to look for common trouble spots.

The Block diagram is a representative sketch of all the components of the console; showing how they connect together and how the signal flows through the system. Once you have become familiar with the various component have gained a valuable understand of the internal structure of the console and tracking down the problem by elimination.

- Swap input connections to check that the source is really present. Check both Mic and Line inputs.
- Eliminate sections of the channel by using the insert point to re-route the signal to other inputs that are known to be working
- Route channels to different outputs or to aux sends to identify problems on the master section.
- Compare a suspect channel with an adjacent channel which had been set up identically. Use PFL to monitor the signal in each section.

## *F. CAUTIONS ON INSTALLATION*

Please take care of the following points for installations.

1. Install this product at place of good ventilation. and keep a interval over 30cm from the other objects.
2. Install this product at rear side for non-touching of somebody, if possible and avoid an installation of a aisle & the front side of the stage.
3. Cause an obstacle and a drop of product from the vibration of speaker, if you put this product on a speaker for a long time.
4. Avoid strong or using product in condition of excessive heat or cold, or in position where it is likely to be subject to vibration, dust or moisture.
5. Connect the plug into an outlet by the check of power source "AC220V" of the installation place.
6. Install the speaker more front side than the used mic and far away from mic, if possible.
7. Insert a plug of cord closely into the speaker jack at the speaker connection.
8. Clean this product by using soft dry cloth & poly-wax.

## G. HOW TO OPERATE

1. Above all, it is necessary to confirm power voltage.
2. Make sure this appliance power switch is off when connecting the plug of power cord with outlet.
3. Set easy controls to the positions stated belows to avoid loud blasts. Loud blasts may cause damage for your speaker system or your ears when you are wearing headphone.  
Master faders L-R, Sub faders 1-2, Effect fader & Each channel faders.  

Gain control	Turn to the left completely
Hi, freq, Mid, Low	Turn to the center position
Aux 1-2 & Effect control	Turn to the left completely
Pan control	Turn to the left completely

  
Set other turn to the left completely
4. Push power switch marked (1), then the LED will be turned on when start working.
5. Set Master faders L-R to the position between min & mid, after working.
6. Set a certain Channel faders which you want to use to the position between min & mid. After that, Connect input section with external source.
7. To make sound through external sources, turn the Gain control to the right.
8. Adjust tone controls in accordance with your taste.
9. Adjust between Effect fader control towards max from min & effect control to the right, when you want to get echo effect a certain channel. After set a certain channel, adjust delay control & repeat control. Then you can get various echo effect sound.

## H. INSTALLATIONS

FIGURE 5

UNBALANCED 1/4" PLUG

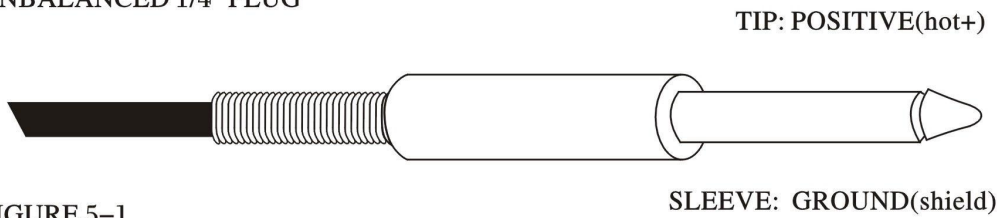

FIGURE 5-1

FEMALE 3 PIN CONNECTOR

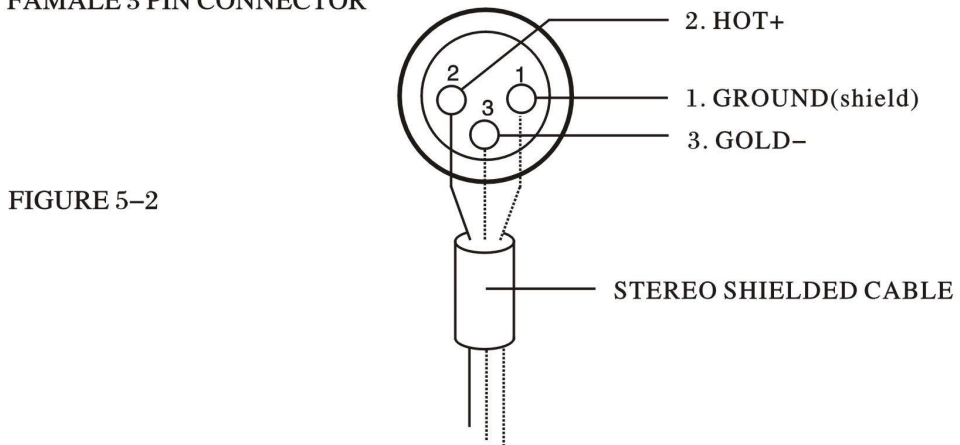
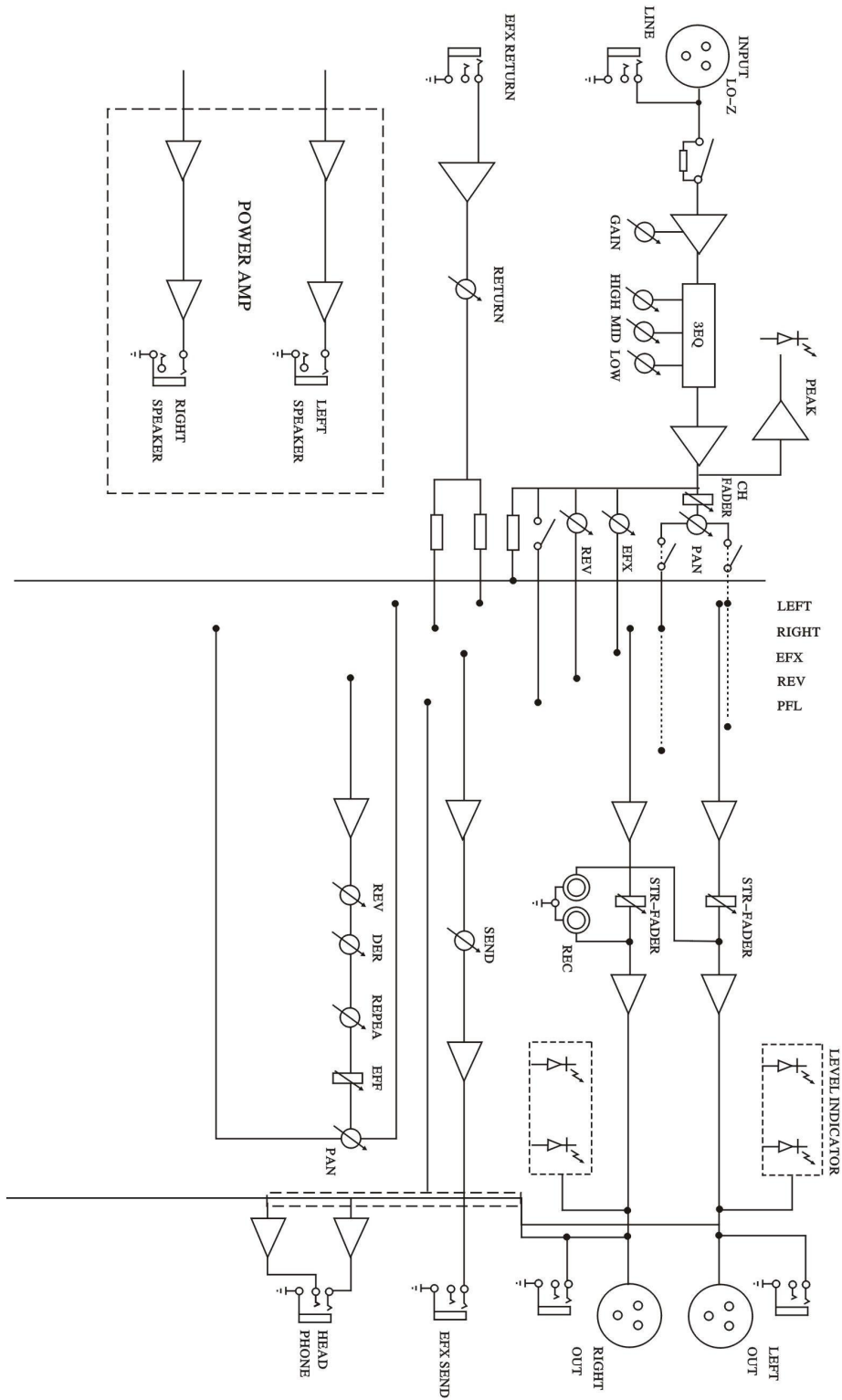

FIGURE 5-2

# I. BLOCK DIAGRAM

## BLOCK DIAGRAM



# I. BLOCK DIAGRAM

## BLOCK DIAGRAM

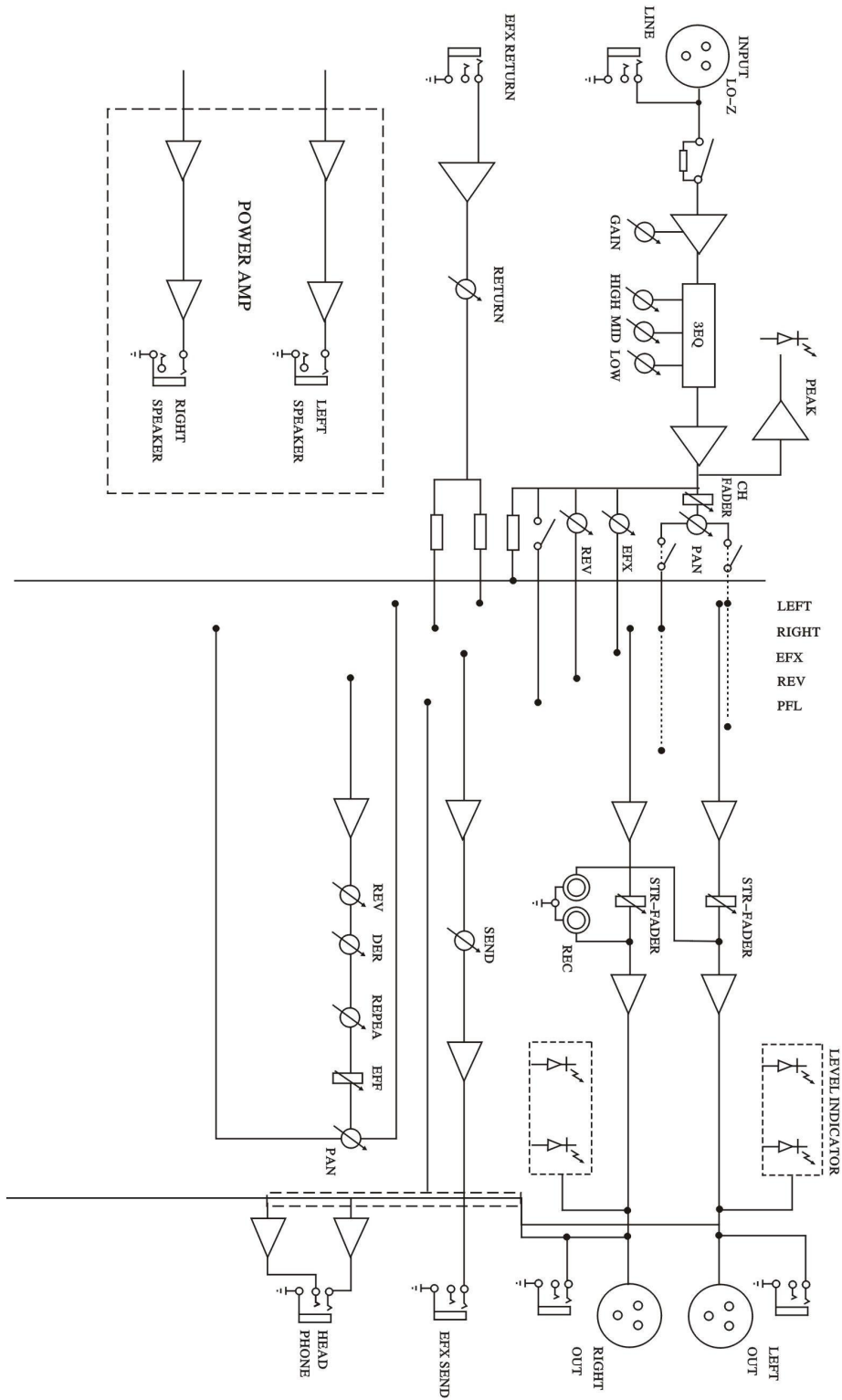

**J. SPECIFICATION**

**MIXER SECTION**

1.INPUT CHANNEL SENSITIVITY	MIC .....	-60dB
	STEREO CH.INPUT .....	-40dB
	EFX SEND .....	-20dB
	EFF,RETURN .....	-20dB
2.OUTPUTS	4V MAX	
3.SIGNAL TO NOISE RATIO	-80dB	
4.PARAMETRIC EQ.	HI .....	+15dB/10KHz
	MID .....	+15dB/250Hz~6KHz
	LOW .....	+15dB/60KHz

POWER SECTION	6 CH	8 CH	12 CH
2.T.H.D	0.1% below(1KHz Full Power)	0.1% below(1KHz full Power)	0.1% below(1KHz full Power)
3.POWER REQUIREMENTS	AC 220V/50Hz or 120V/60Hz	AC 220V/50Hz or 120V/60Hz	AC 220V/50Hz or 120V/60Hz
POWER CONSUMPTION	18 W	20 W	25 W

\*All prices and specifications subject to change without notice.