

Product Dimensions : 19.68" W x 11.81" D x 32.67" H

NOTICE

- * Please make sure that you have all parts indicated and they are in good condition before you begin assembly of this item. Refer to part list and hardware list below for guidance.
- * This item should be assembled on a soft surface to prevent scratching the finish during assembly.
- * This item may require periodic tightening.
- * If you are having difficulty, our friendly Customer Care team is always here to help.

PREPARATION

- * Before beginning assembly of product, make sure all parts are present. Compare parts with part contents list and hardware contents list.
- * If any part is missing or damaged, do not attempt to assemble the product.
- * Estimated assembly time : **15 minutes**
- * Tools required for assembly (included) : **Allen key**
- * Tools required for assembly (not included) : **Philip screw driver**

CARE AND MAINTENANCE

Always use felt pads under all articles to prevent discoloration or softening of the lacquer. Plastic and rubber bases on items can discolor wood. Wipe up spill immediately and avoid common hazards such as hot dishes, harsh solvents and abrasives. Cleaning should be done with a soft lint free cotton cloth dampened with water or furniture polish. On highly used surface we recommend applying a quality paste wax which should be used on a regular basis to provide additional protection from scratches and spills. How often you apply the wax depends on how much wear the furniture receives.

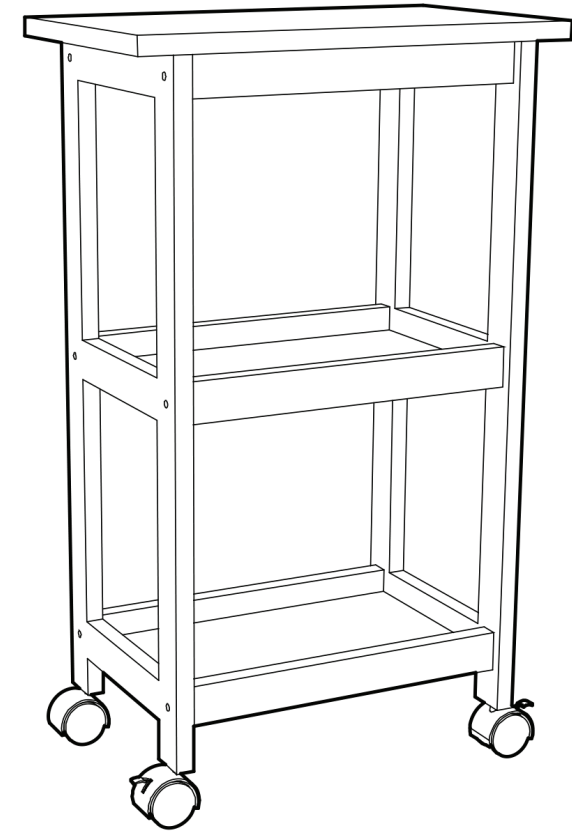









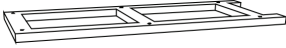

Weight capacity - 92 LBS

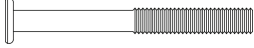
Warning : Do not stand on table.

Warning : Do not over torque bolts.

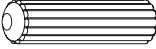
Part List and Hardware List

PIECE	DESCRIPTION	PICTURE	QUANTITY
A	Table Top		1x
B	Side Panel		2x
C	Support Brace 1		2x
D	Support Brace 2		4x
E	Shelf		2x
HW 1	Jcbc Bolt M6x1.0x60mm		12x
HW 2	Screw M4x2.0x30mm		4x
HW 3	Barrel Nut		12x
HW 4	Allen Key M4		1x
HW 5	Wood Dowel 8x30mm		4x
HW 6	Castor Wheel		2x
HW 7	Castor Wheel with Lock		2x

PREPARATION

- * Before beginning assembly of product, make sure all parts are present. Compare parts with part contents list and hardware contents list.
- * If any part is missing or damaged, do not attempt to assemble the product.
- * Estimated assembly time : 15 minutes
- * Tools required for assembly (included) : Allen key
- * Tools required for assembly (not included) : Philip screw driver
- * If you are having difficulty, our friendly Customer Care team is always here to help.

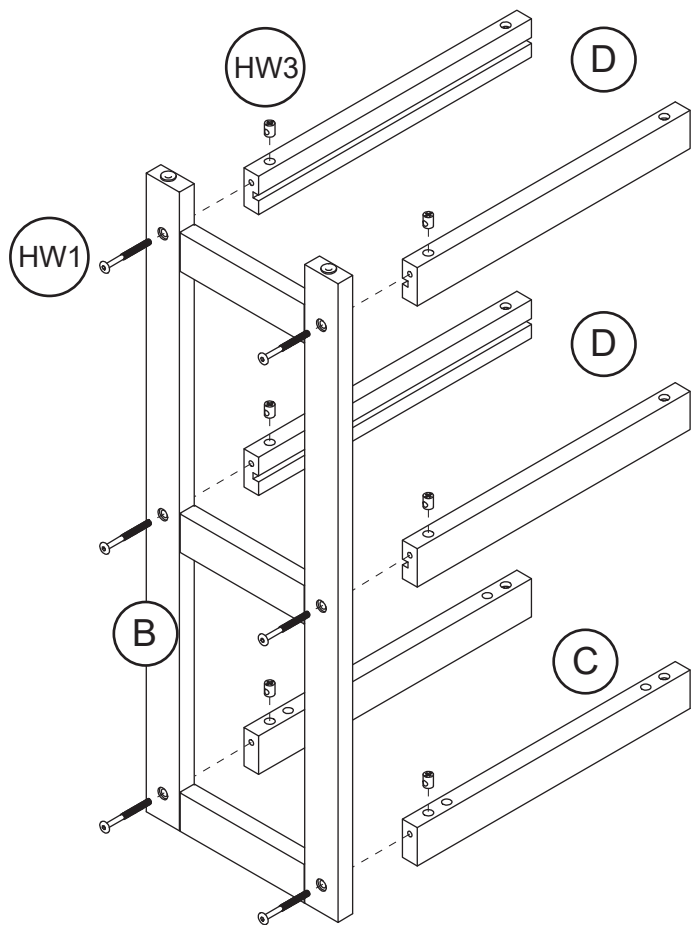

Step 1 : Insert barrel nut (HW3) into the first hole of Support Brace 1 (C) and Support Brace 2 (D). Attach Support Brace 1 (C) and Support Braces 2 (D) to the Side Panel (B) using the bolts (HW1).

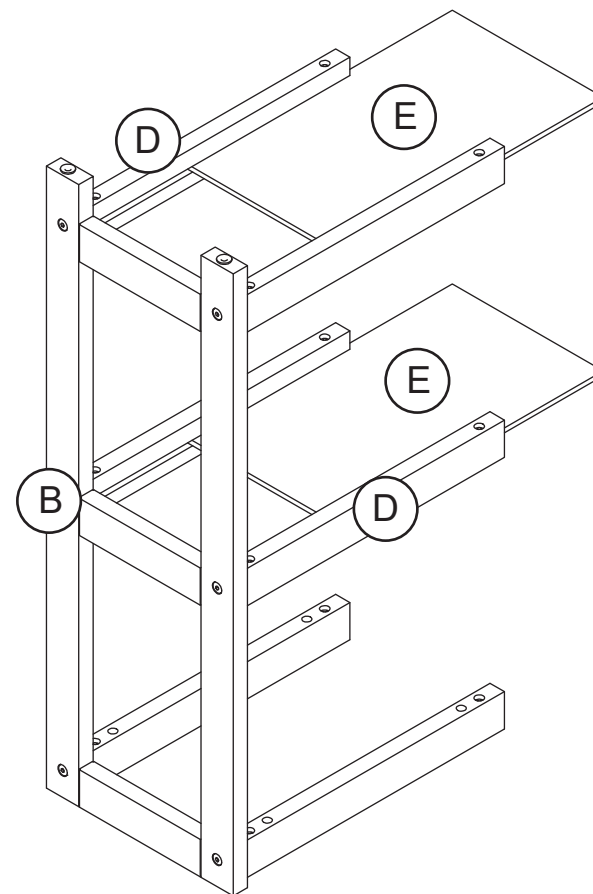

Step 2 : Slot in the Shelves (E) into the groove of Support Brace 2 (D).

PREPARATION

- * Before beginning assembly of product, make sure all parts are present. Compare parts with part contents list and hardware contents list.
- * If any part is missing or damaged, do not attempt to assemble the product.
- * Estimated assembly time : 15 minutes
- * Tools required for assembly (included) : Allen key
- * Tools required for assembly (not included) : Philip screw driver
- * If you are having difficulty, our friendly Customer Care team is always here to help.

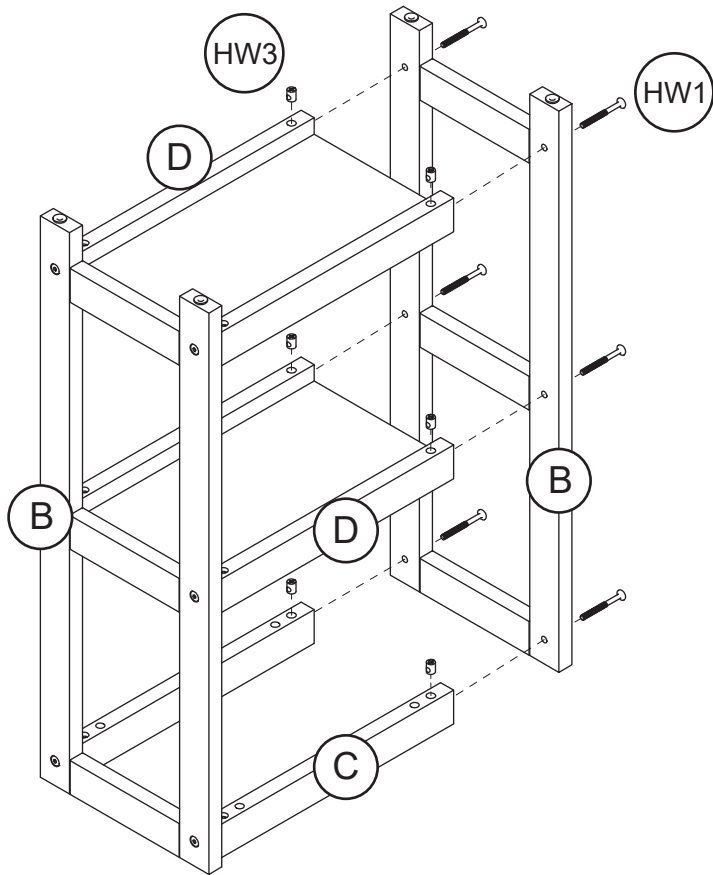

Step 3 : Insert the barrel nut (HW3) into the first hole of Support Brace 1 (C) and Support Brace 2 (D). Attach the Side Panel (B) to the Support Brace 1 (C) and Support Brace 2 (D) using the bolts (HW1).

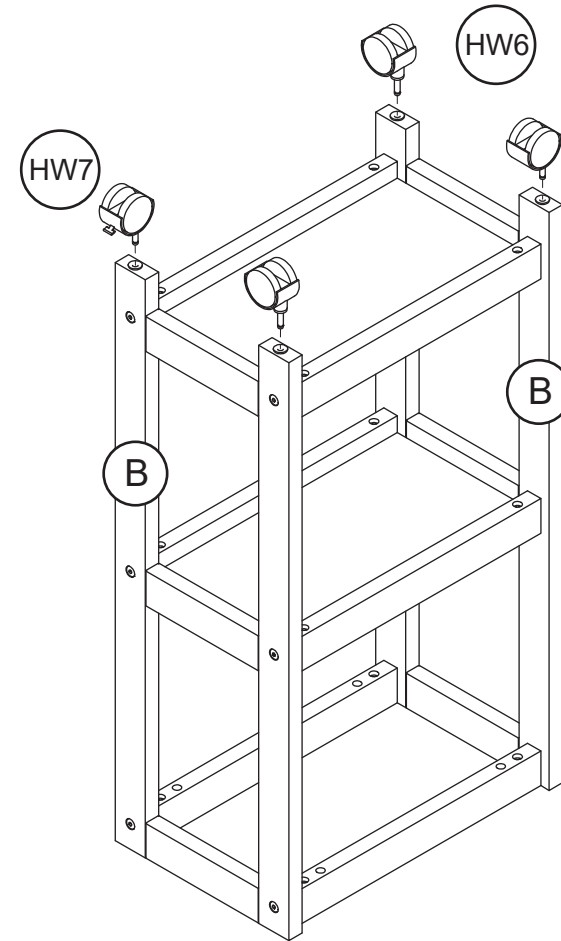

Step 4 : Push in the castor wheel (HW6)(HW7) into the socket hole.

PREPARATION

- * Before beginning assembly of product, make sure all parts are present. Compare parts with part contents list and hardware contents list.
- * If any part is missing or damaged, do not attempt to assemble the product.
- * Estimated assembly time : 15 minutes
- * Tools required for assembly (included) : Allen key
- * Tools required for assembly (not included) : Philip screw driver
- * If you are having difficulty, our friendly Customer Care team is always here to help

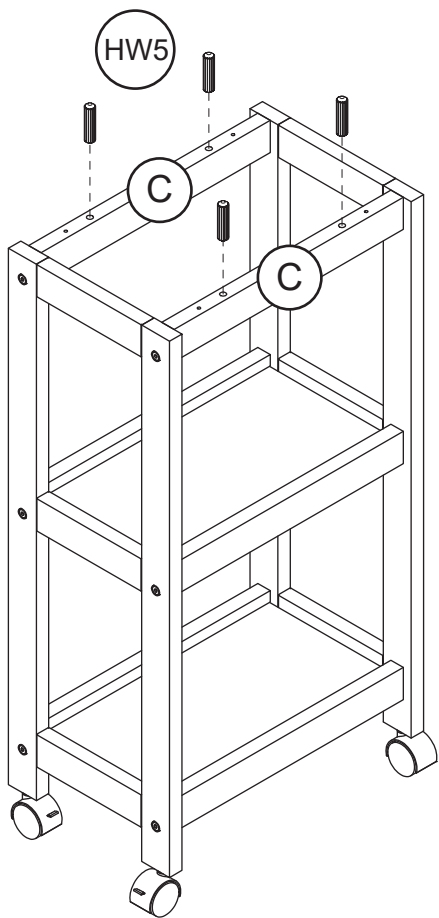

Step 5 : Upright the assembled part. Insert wood dowel (HW5) to the Support Brace 1 (C).

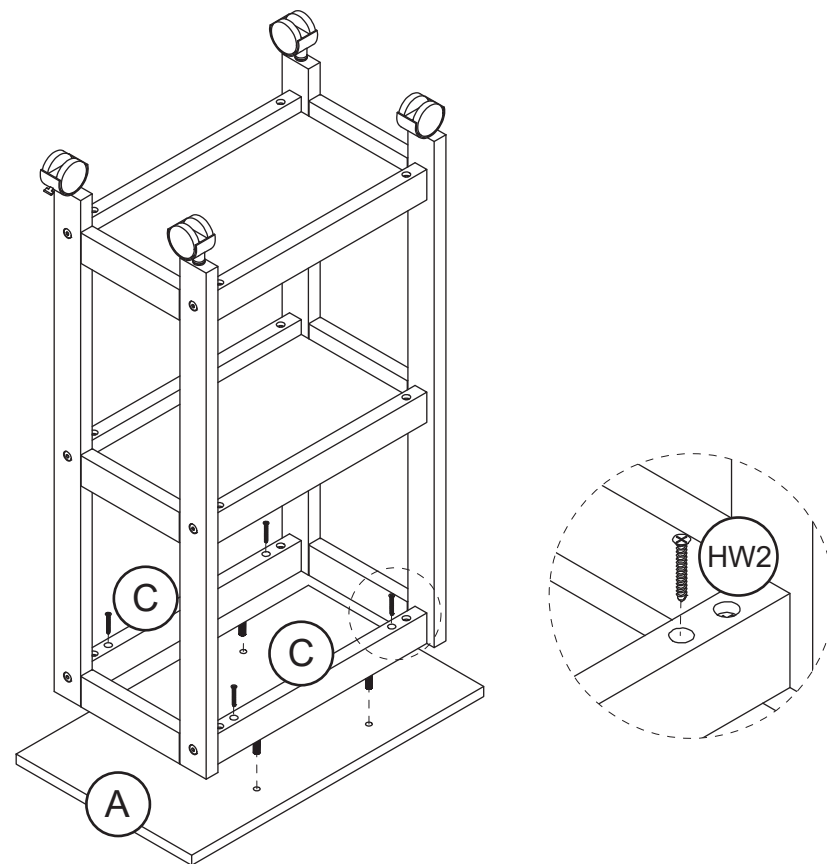

Step 6 : Turn the assembled part upside down. Align the wood dowel at the Support Brace 1 (C) to the Top Panel (A). Screw the assembled part to the Top Panel using the screws (HW2).