



20632

TIMBERWOOD PLAYHOUSE
MAISON DE JEUX TIMBERWOOD
CASA DE JUEGOS TIMBERWOOD



CALL US OR GO ONLINE
APPELEZ-NOUS OU ALLEZ EN LIGNE
LLÁMENOS O VISITE NUESTRO SITIO WEB

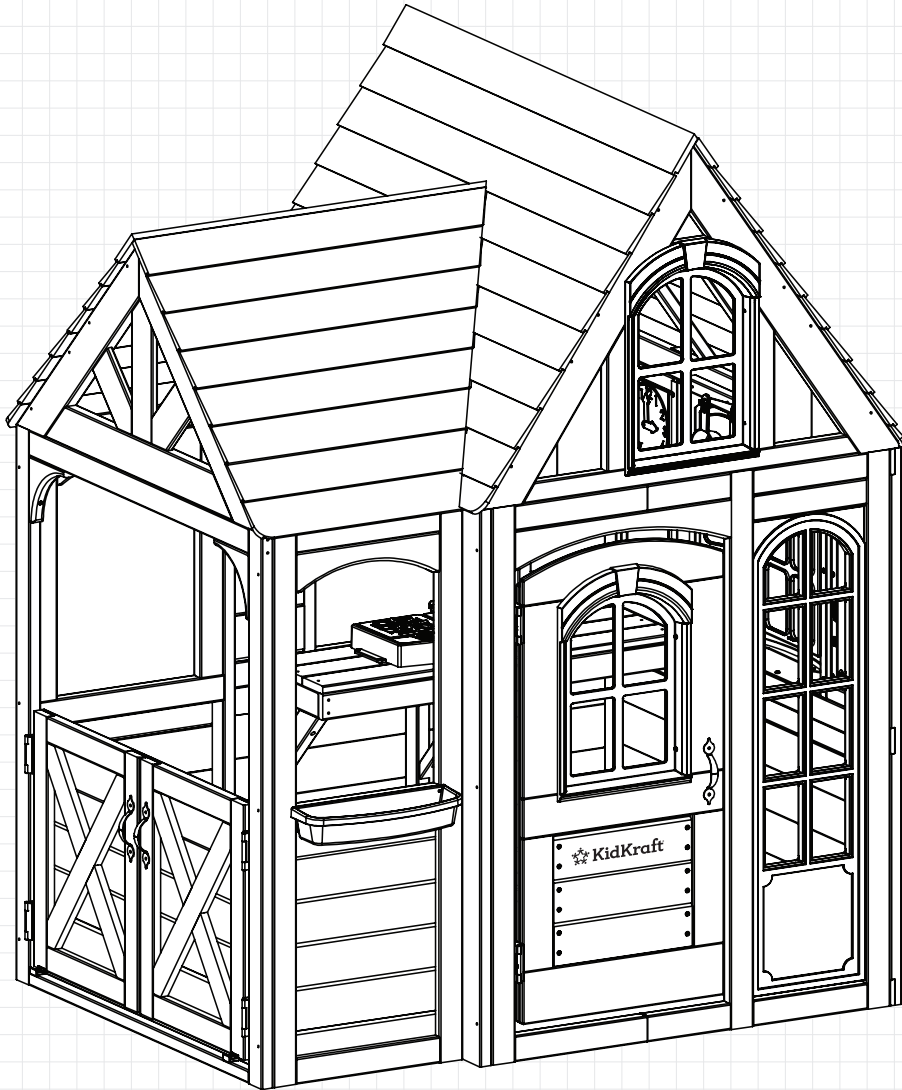

ASSEMBLY INSTRUCTIONS / INSTRUCTIONS D'ASSEMBLAGE / INSTRUCCIONES DE MONTAJE

**FOR 24/7 ONLINE PARTS REPLACEMENT / POUR LE
REPLACEMENT 24/7 DES PIÈCES EN LIGNE / PARA SOLICITUDES
ONLINE DE PIEZAS DE REPUESTO DE MANERA ININTERRUMPIDA**

BATCH CODE / CODE DE LOT / CÓDIGO DE LOTE

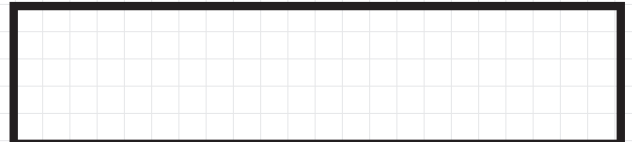

parts.kidkraft.com

Backyard Kids, LLC DBA KidKraft
317 S. Main St.
Ann Arbor, MI 48104

customerservice@kidkraft.com
1.800.933.0771
972.385.0100

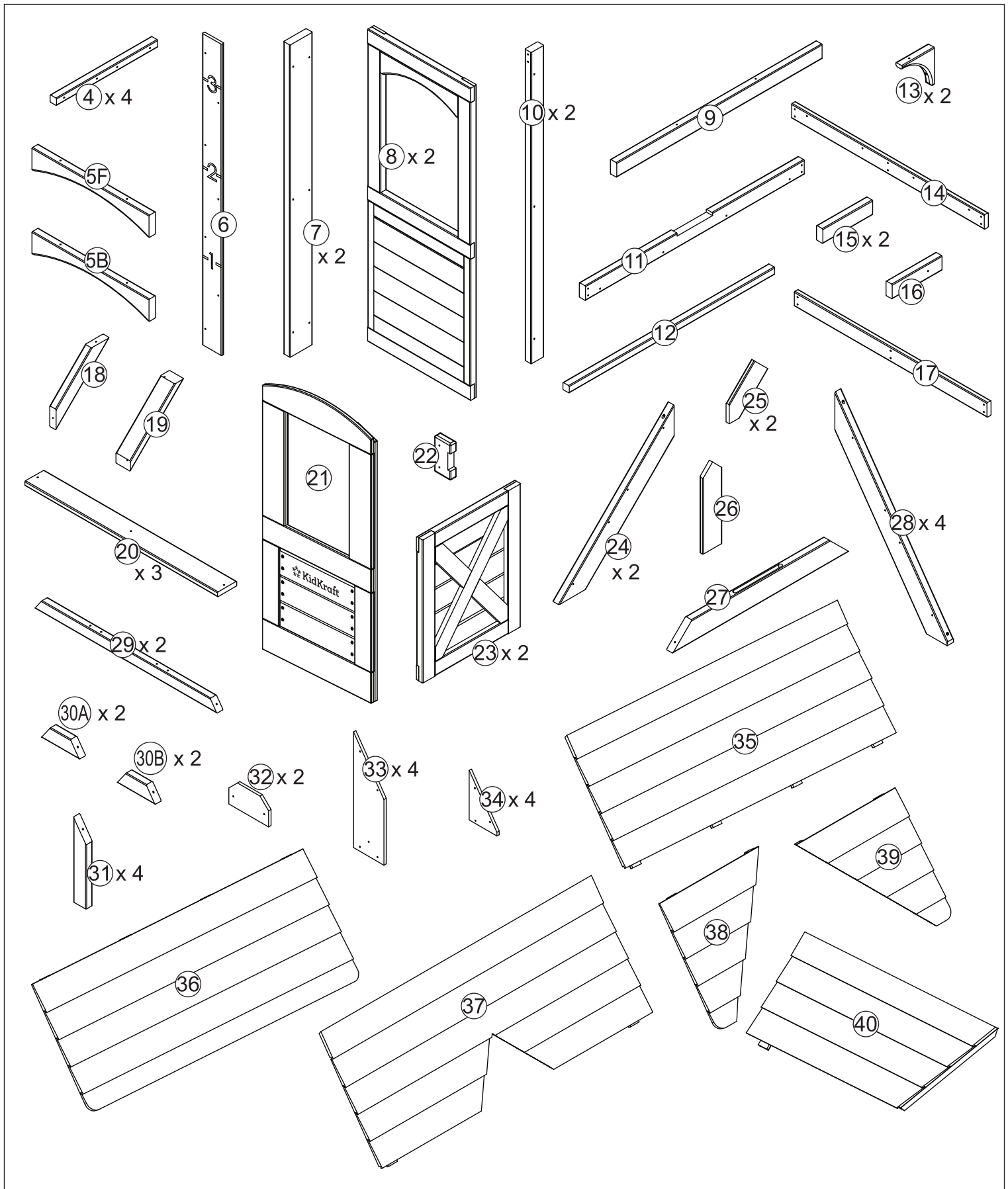



Parts and Hardware
 Pièces et matériel
 Partes y Piezas Para Instalación
 Teile und Befestigungsmaterial
 Parti e componenti meccanici

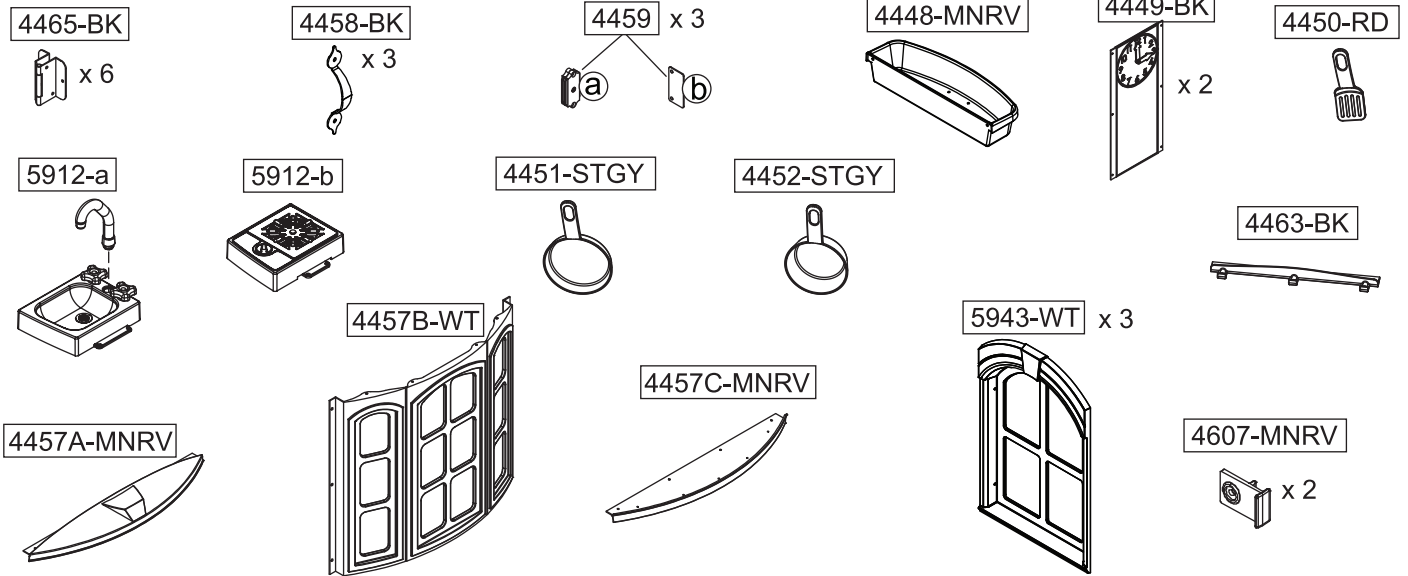
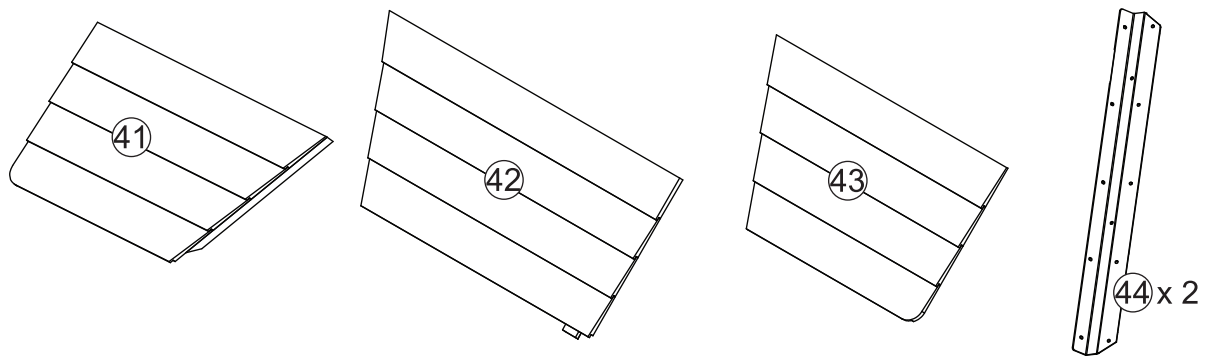

parts.kidkraft.com

customerservice@kidkraft.com
 1.800.933.0771
 972.385.0100

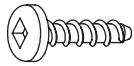
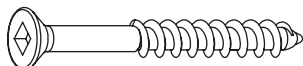
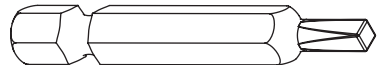
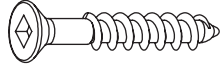

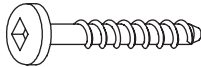
A	x 130	D	x 16	x 1
				
18 mm		50 mm		
B	x 68	E	x 31	
				
35 mm		75 mm		
C	x 79	F	x 6	
				
45 mm		29 mm		

Parts and Hardware
 Pièces et matériel
 Partes y Piezas Para Instalación
 Teile und Befestigungsmaterial
 Parti e componenti meccanici

All hardware dimensions are approximate.
 Toutes les dimensions du matériel
 sont approximatives.
 Todas las dimensiones de las herramientas
 son aproximaciones.



parts.kidkraft.com

customerservice@kidkraft.com
 1.800.933.0771
 972.385.0100

If you need to order parts,
please order below part#

Si necesita pedir piezas, utilice el número
de pieza indicado a continuación para
realizar el pedido

Si vous avez besoin de commander des
pièces, veuillez utiliser le numéro de
référence ci-dessous.

Wenn Sie Teile bestellen müssen,
tun Sie dies bitte über die folgende
Teilenummer:

Se è necessario ordinare i pezzi,
ordinare il pezzo n° di seguito

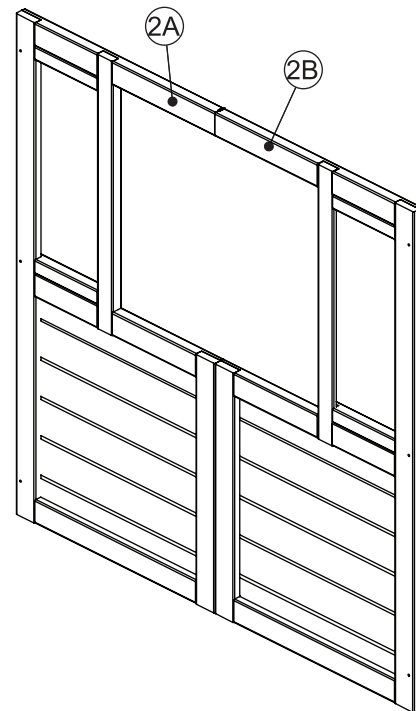
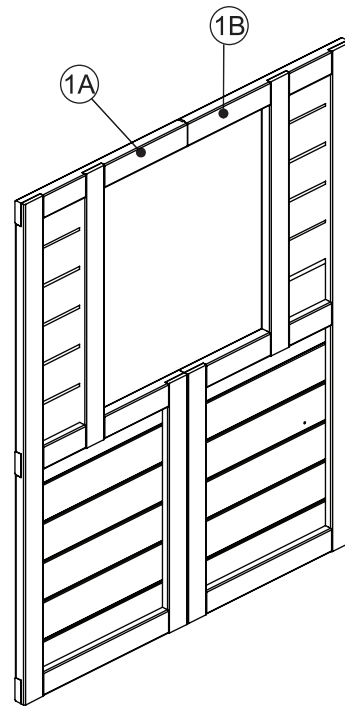

- P-20632-1A
- P-20632-1B
- P-20632-2A
- P-20632-2B
- P-20632-ZZ1
- 9323687

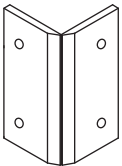

9323687
(6 Pcs)

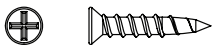

ZZ1
(24 Pcs)

Parts and Hardware
Pièces et matériel
Partes y Piezas Para Instalación
Teile und Befestigungsmaterial
Parti e componenti meccanici



parts.kidkraft.com

customerservice@kidkraft.com
1.800.933.0771
972.385.0100

If you need to order parts,
please order below part#

Si necesita pedir piezas, utilice el número
de pieza indicado a continuación para
realizar el pedido

Si vous avez besoin de commander des
pièces, veuillez utiliser le numéro de
référence ci-dessous.

Wenn Sie Teile bestellen müssen,
tun Sie dies bitte über die folgende
Teilenummer:

Se è necessario ordinare i pezzi,
ordinare il pezzo n° di seguito

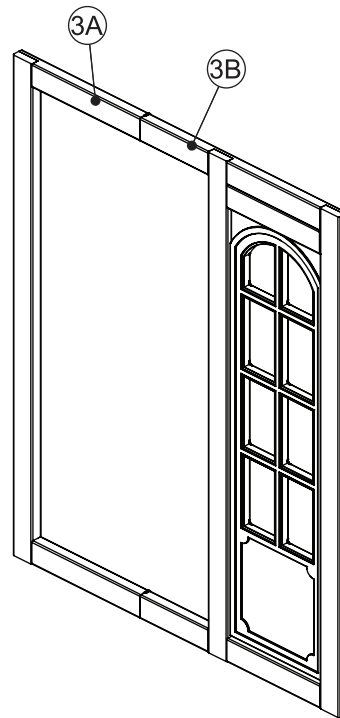

P-20632-3A

P-20632-3B

P-20632-ZZ1

9323687

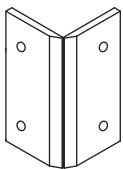

9323687
(2 Pcs)



ZZ1
(8 Pcs)

Parts and Hardware
Pièces et matériel
Partes y Piezas Para Instalación
Teile und Befestigungsmaterial
Parti e componenti meccanici



parts.kidkraft.com

customerservice@kidkraft.com
1.800.933.0771
972.385.0100

1

1 x ①

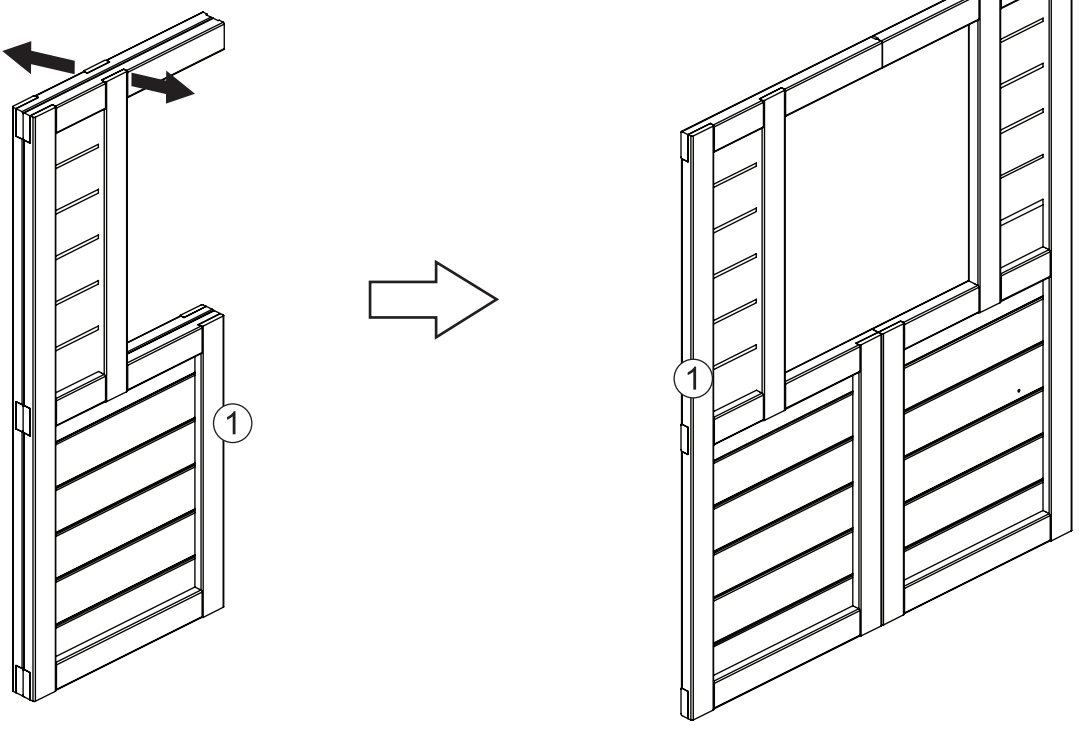

2

1 x ②

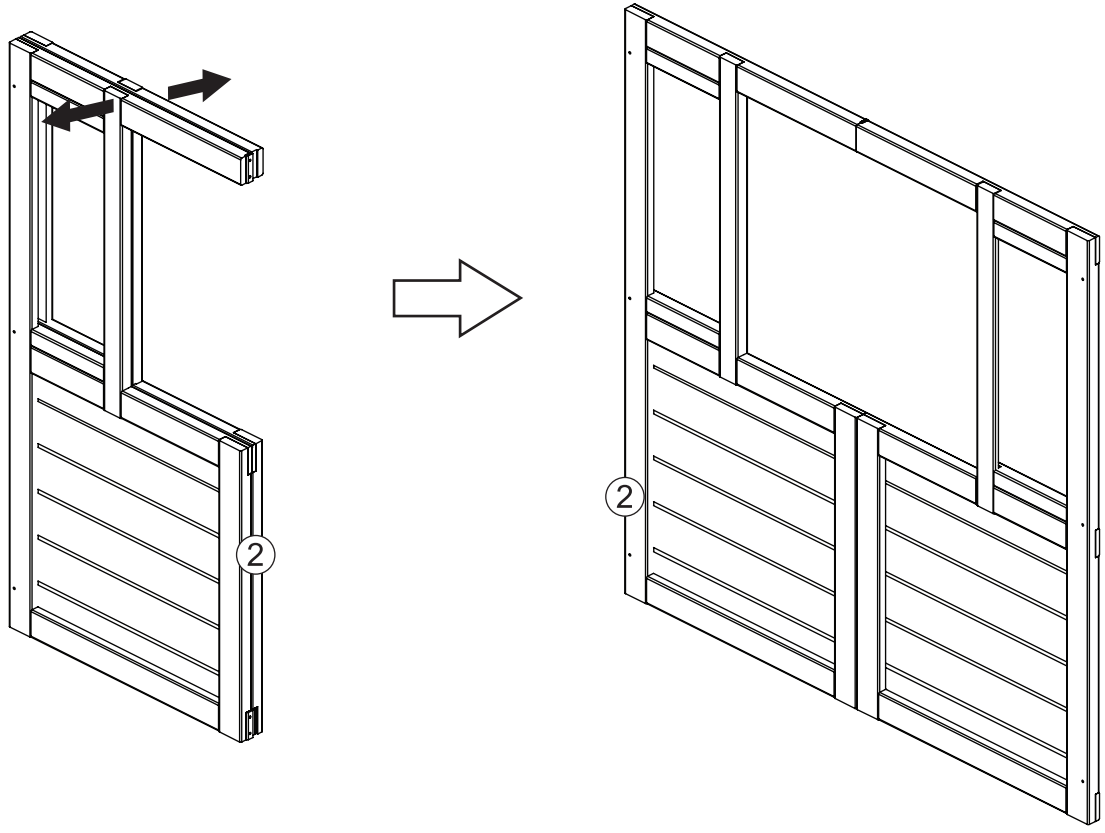

3

Make sure assembly is square.
Assurez-vous que l'assemblage soit bien droit.
Asegúrese de que el conjunto esté en perpendicular.
Die Bauteile müssen sich im rechten Winkel zueinander befinden.
Accertarsi che l'assemblato sia in squadra.

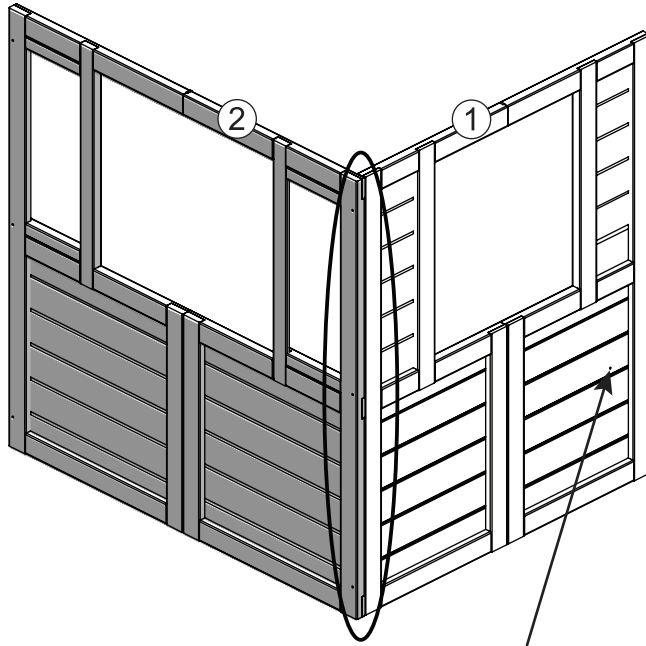

Notice hole orientation
Faites attention à l'orientation des trous
Tenga en cuenta la orientación de los orificios
Ausrichtung der Bohrungen beachten
Prestare attenzione all'orientamento dei fori

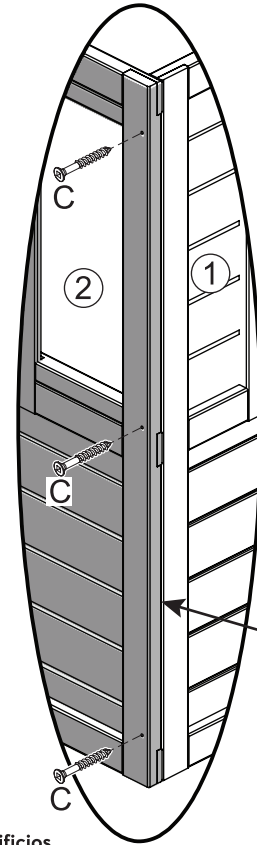

3 x C



4

1 x 3

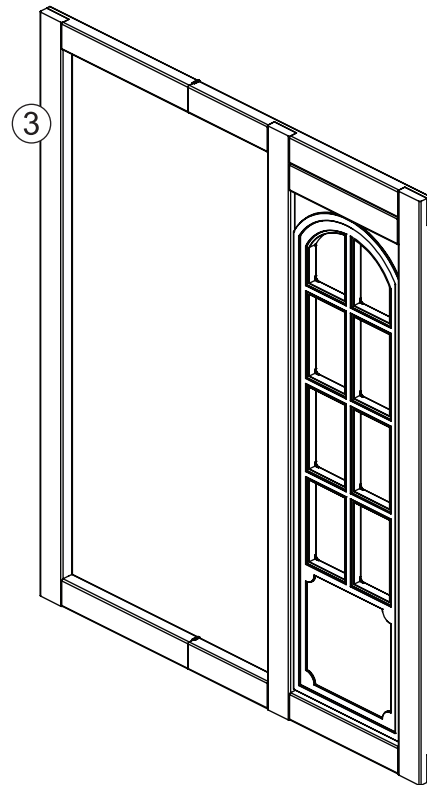
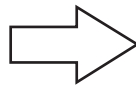
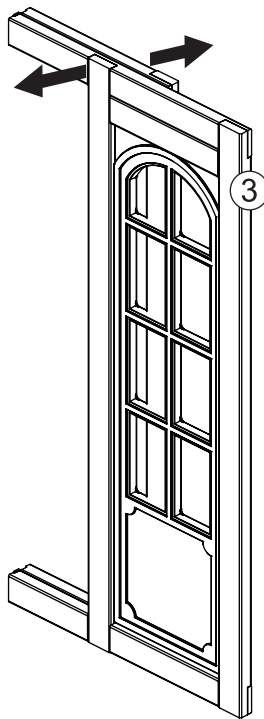

5

Make sure assembly is square.
Assurez-vous que l'assemblage soit bien droit.
Asegúrese de que el conjunto esté en perpendicular.
Die Bauteile müssen sich im rechten Winkel zueinander befinden.
Accertarsi che l'assemblato sia in squadra.

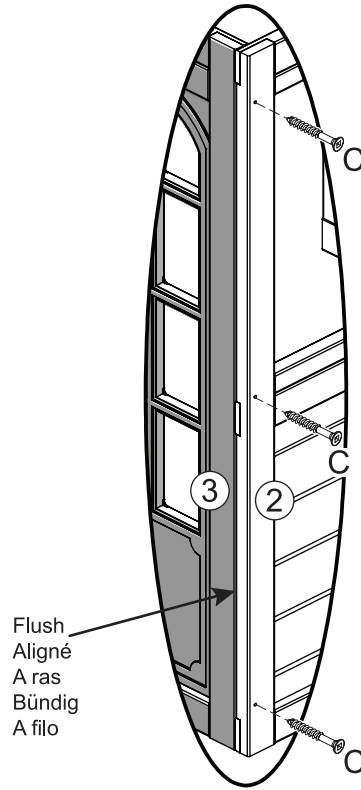
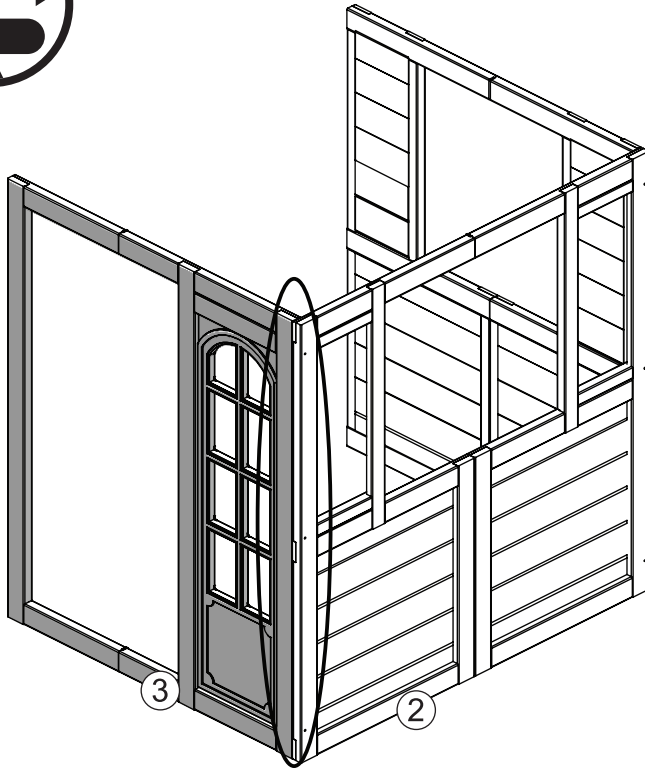

3 x C



6



2 x 4

8 x C

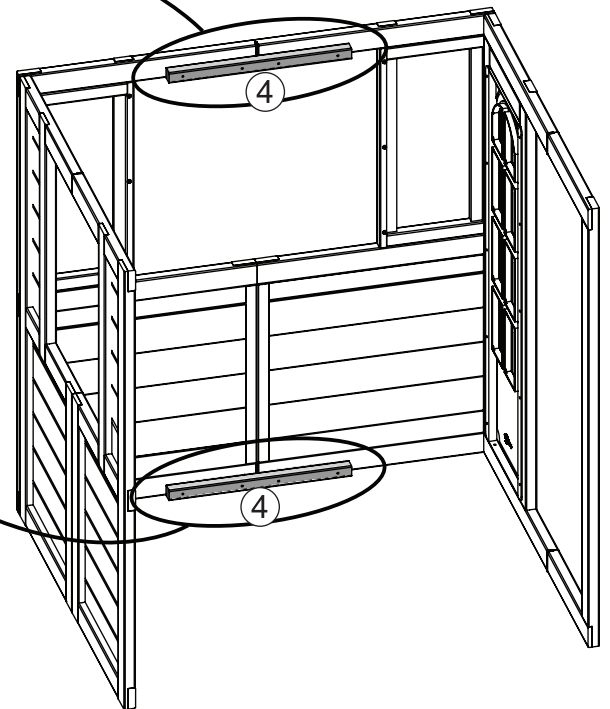
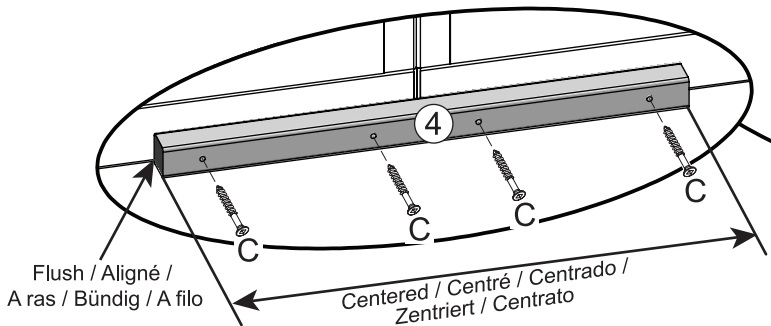
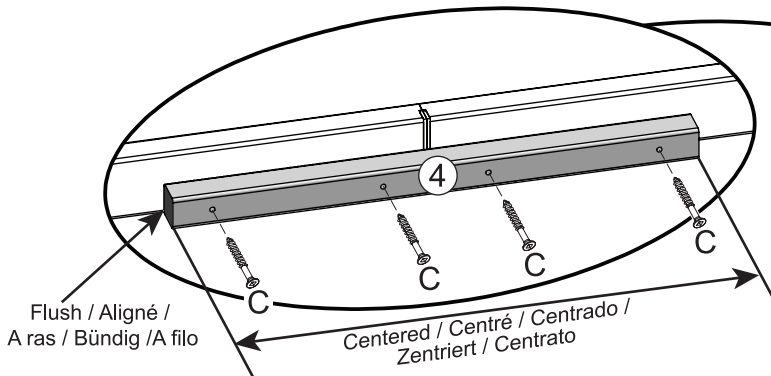

7



1 x 4

4 x C

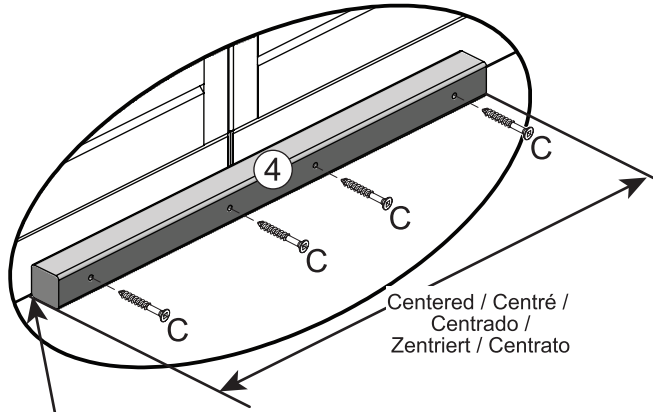

Flush / Aligné /
A ras / Bündig / A filo

Centered / Centré /
Centrado /
Zentriert / Centrato

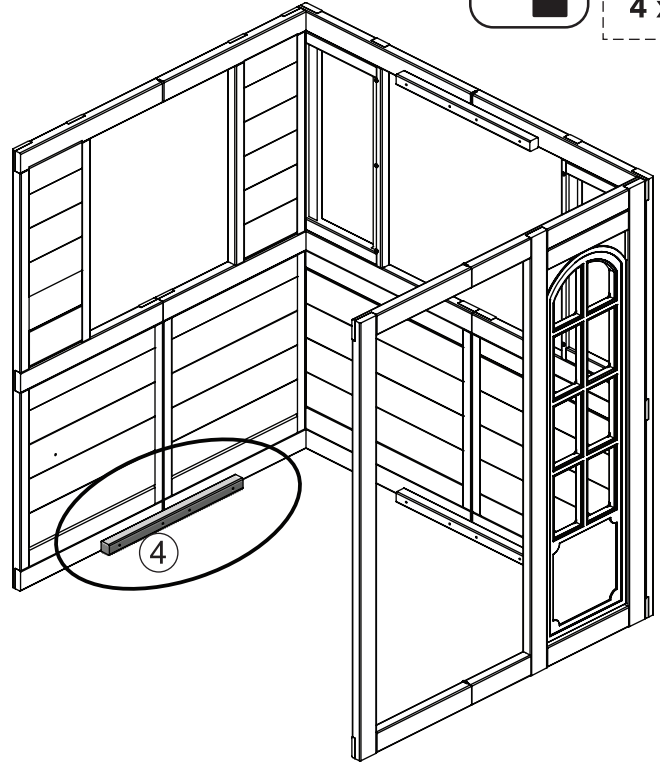

8



1 x 4

4 x C

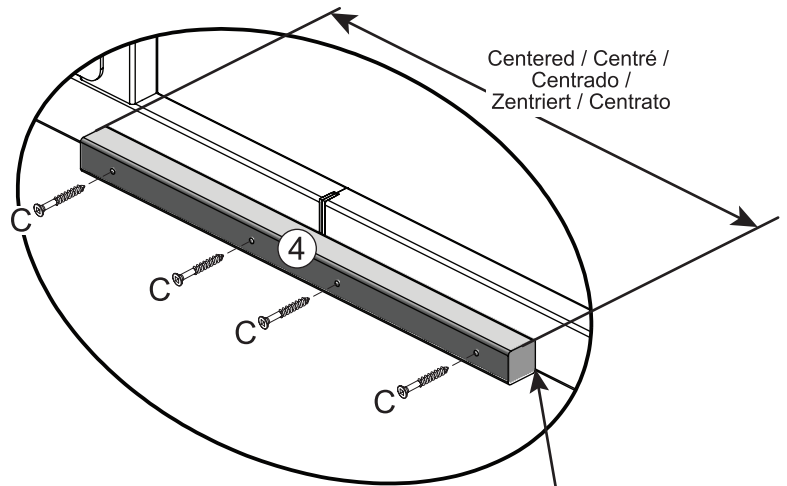
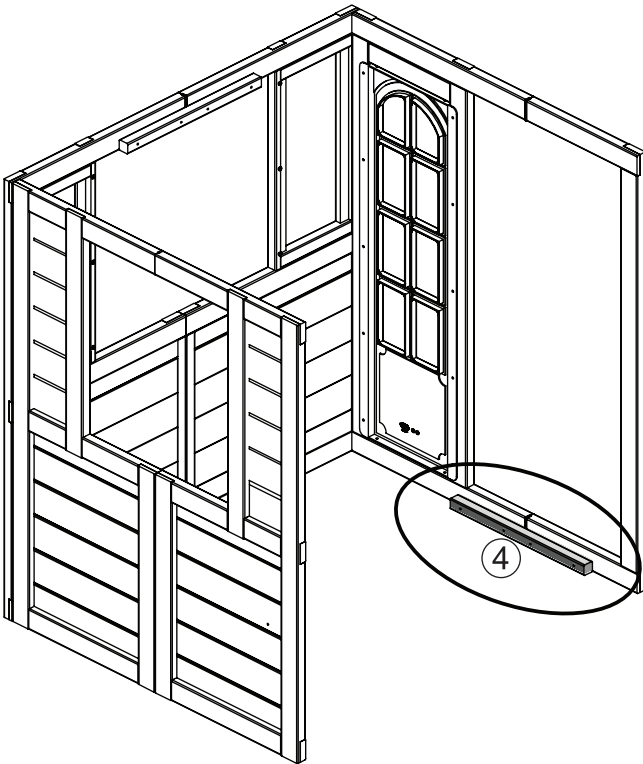

Centered / Centré /
Centrado /
Zentriert / Centrato

Flush / Aligné /
A ras / Bündig / A filo



1 x 5F

1 x 5B

4 x E

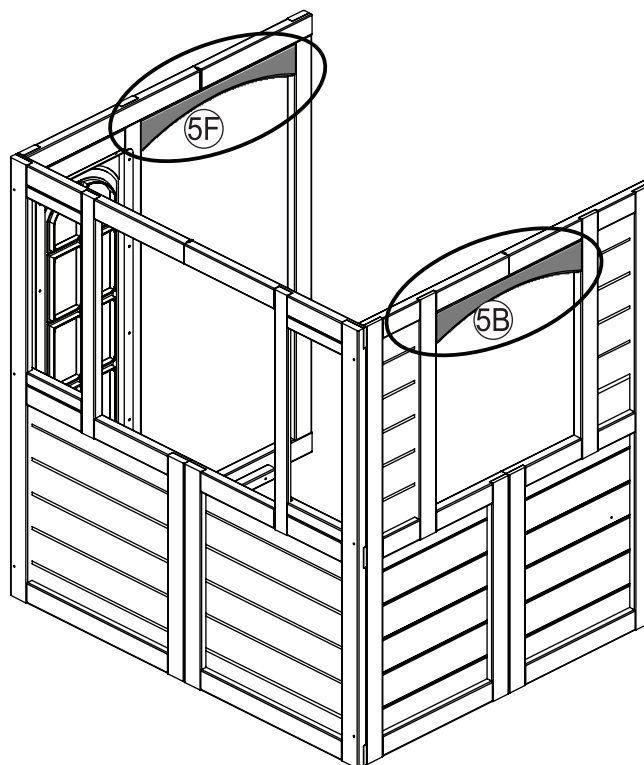

Flush / Aligné /
A ras / Bündig / A filo

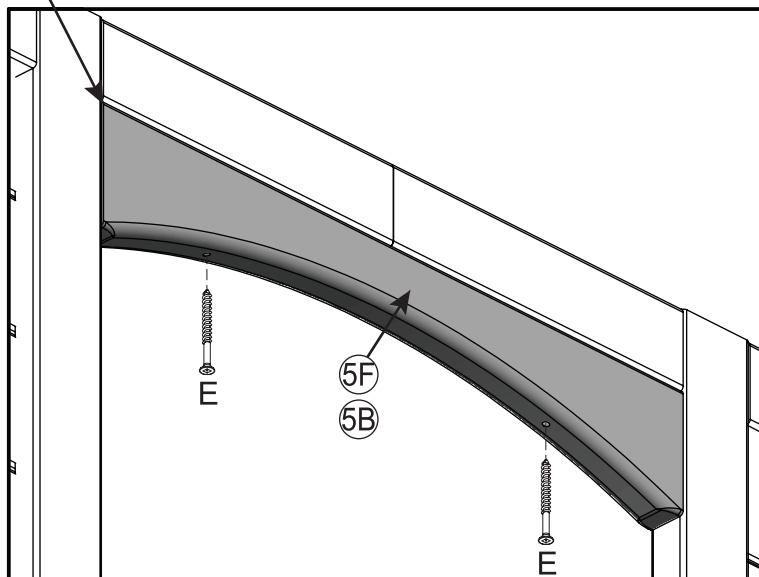

10

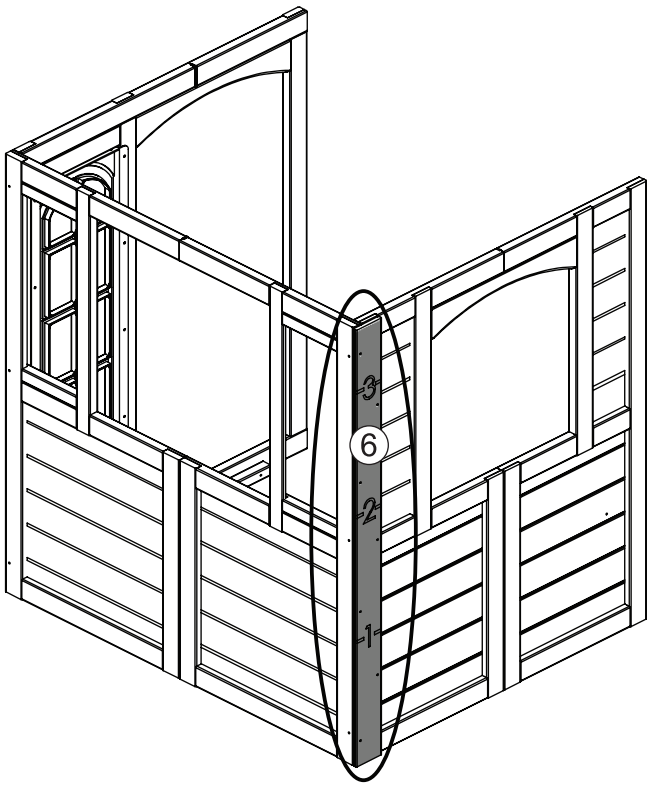

Flush
Aligné
A ras
Bündig
A filo

1 x 6

7 x B

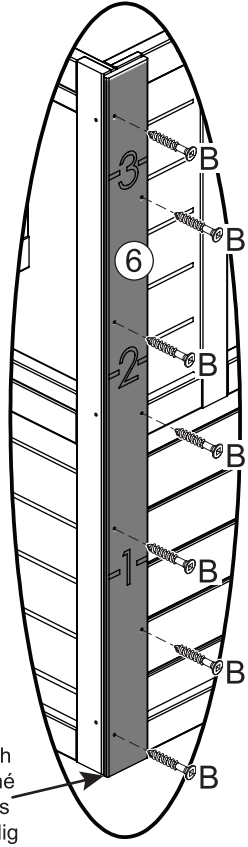

11

Flush
Aligné
A ras
Bündig
A filo

2 x 7

6 x C

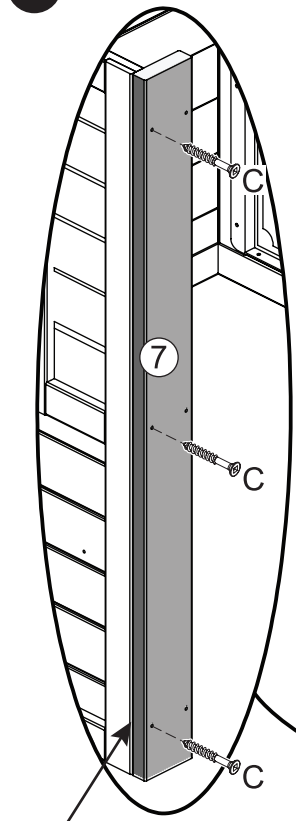

Flush / Aligné /
A ras / Bündig / A filo

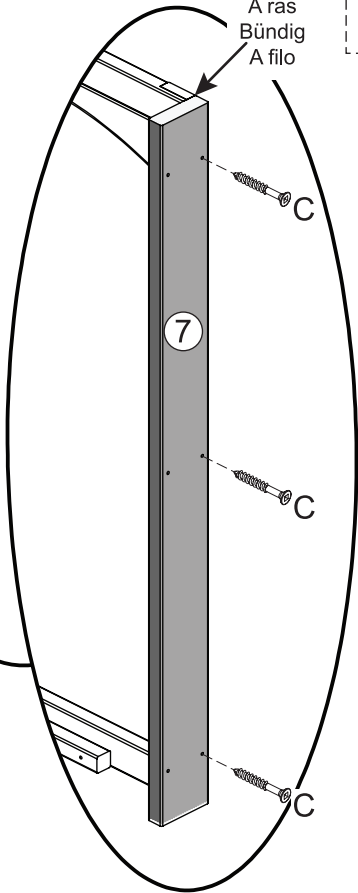
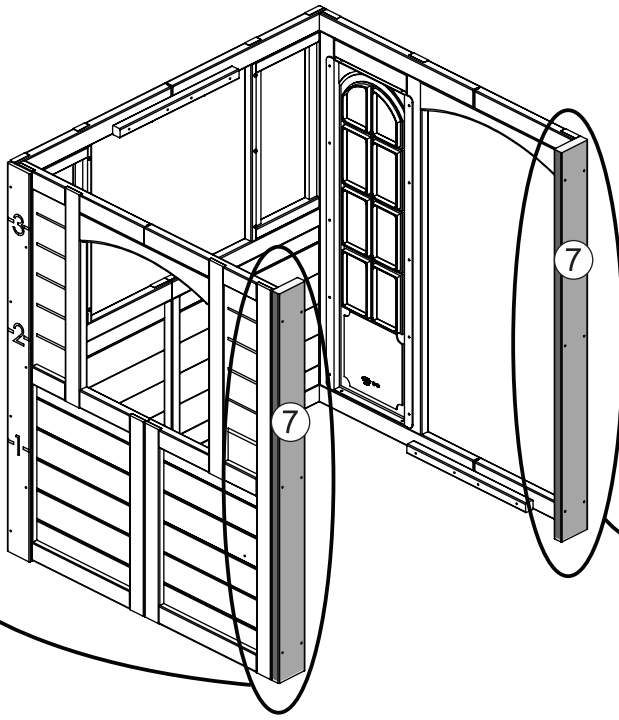

parts.kidkraft.com

customerservice@kidkraft.com
1.800.933.0771
972.385.0100

12

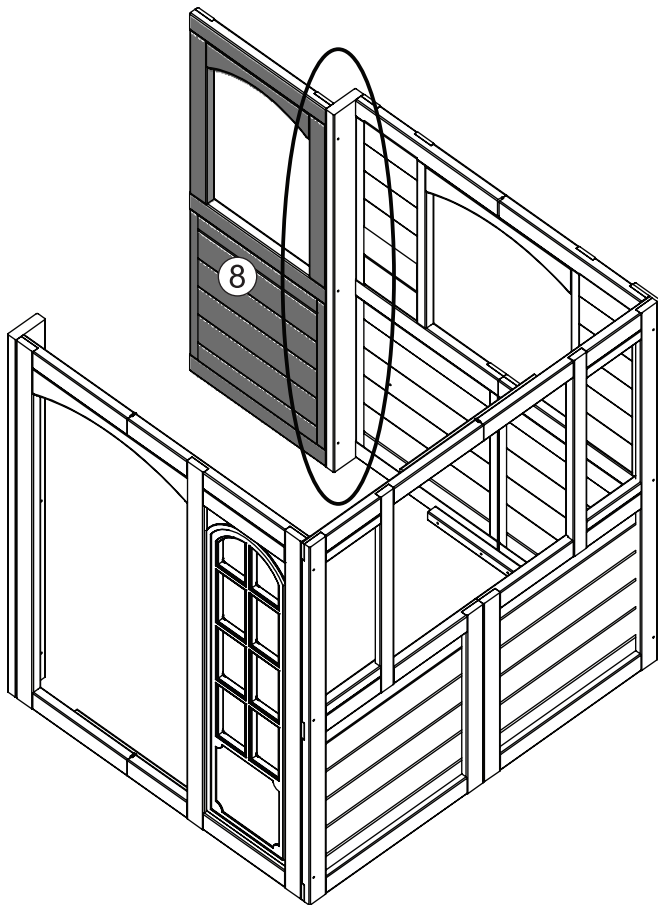

Flush
Aligné
A ras
Bündig
A filo

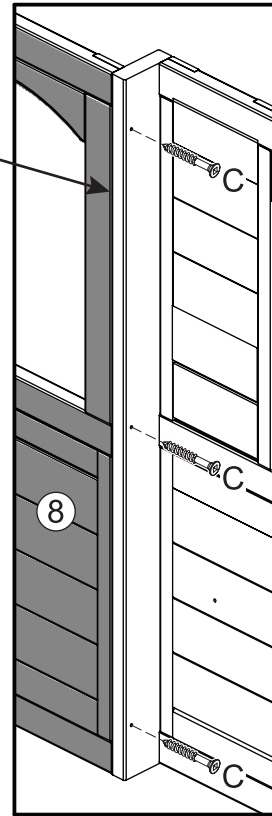

1 x 8

3 x C



13

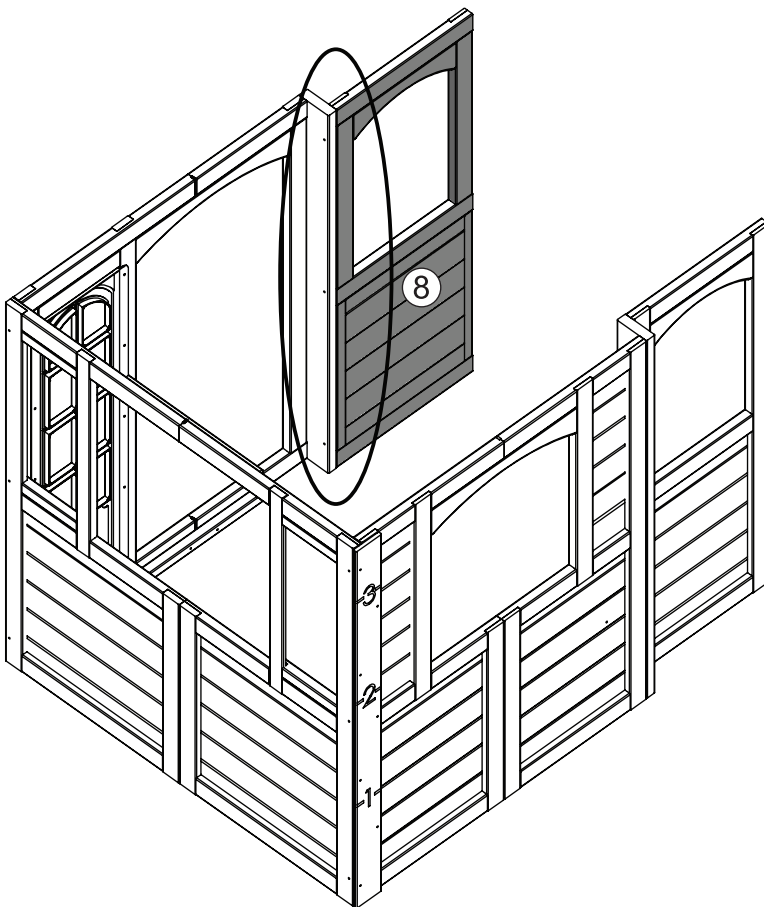

1 x 8

3 x C

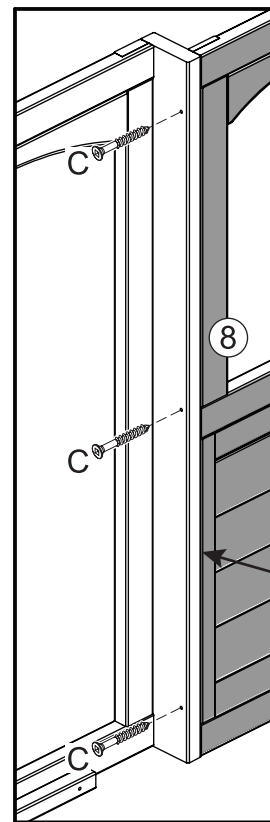

Flush
Aligné
A ras
Bündig
A filo

14

Make sure assembly is square.
Assurez-vous que l'assemblage soit bien droit.
Asegúrese de que el conjunto esté en perpendicular.
Die Bauteile müssen sich im rechten Winkel zueinander befinden.
Accertarsi che l'assemblato sia in squadra.

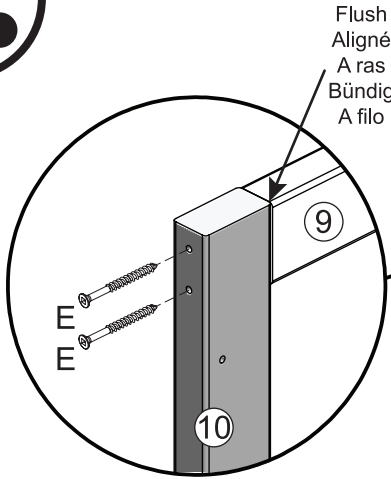

Flush
Aligné
A ras
Bündig
A filo

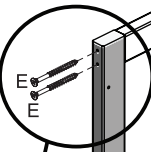

10

9

10

Notice hole orientation
Faites attention à l'orientation des trous
Tenga en cuenta la orientación de los orificios
Ausrichtung der Bohrungen beachten
Prestare attenzione all'orientamento dei fori



1 x 9

2 x 10

4 x E



15

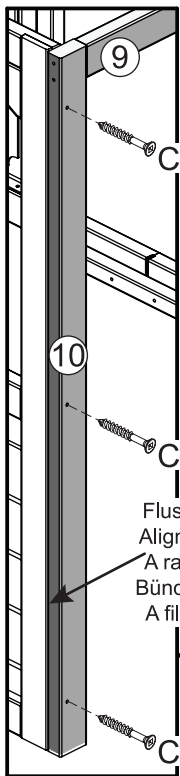

Flush
Aligné
A ras
Bündig
A filo

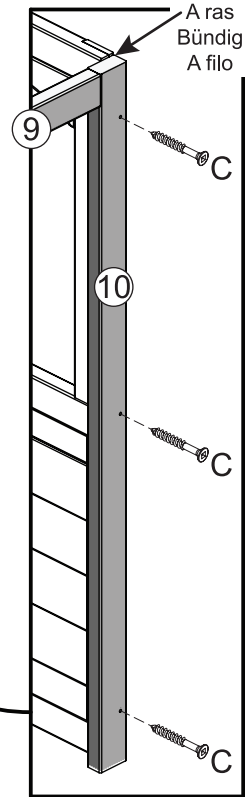
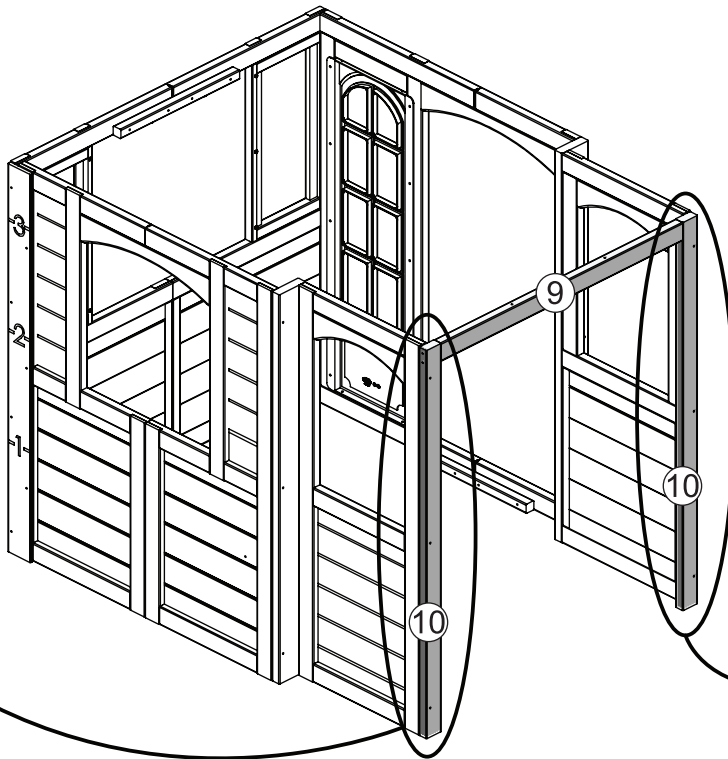

Flush
Aligné
A ras
Bündig
A filo

6 x C



16

1 x 11

4 x C



Note orientation of notch
Notez l'orientation de l'entaille
Tenga en cuenta la orientación de la muesca
Ausrichtung der Kerbe beachten
Prestare attenzione all'orientamento della scanalatura

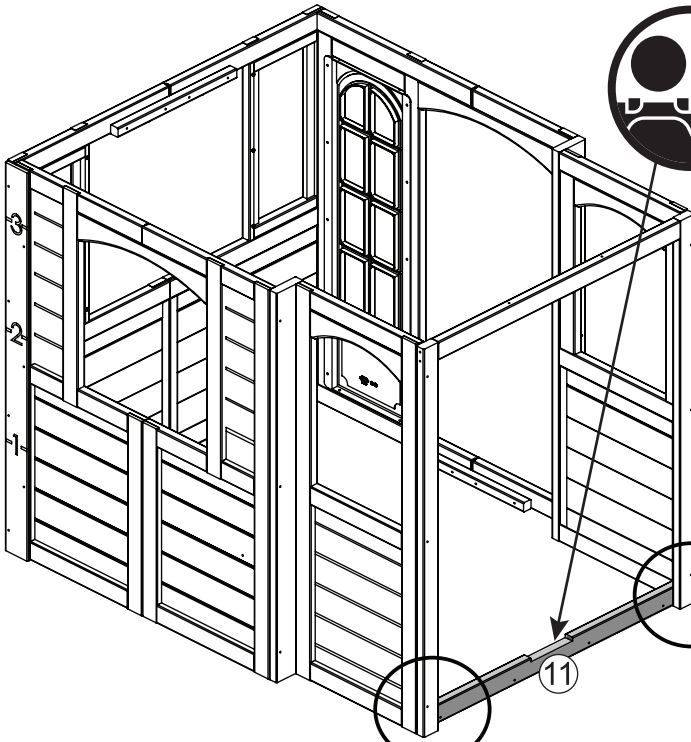

Tight
Serré
Apretado
Fest
Stretto

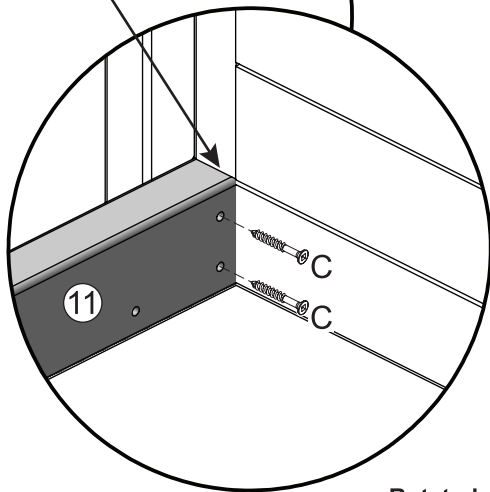

Tight
Serré
Apretado
Fest
Stretto

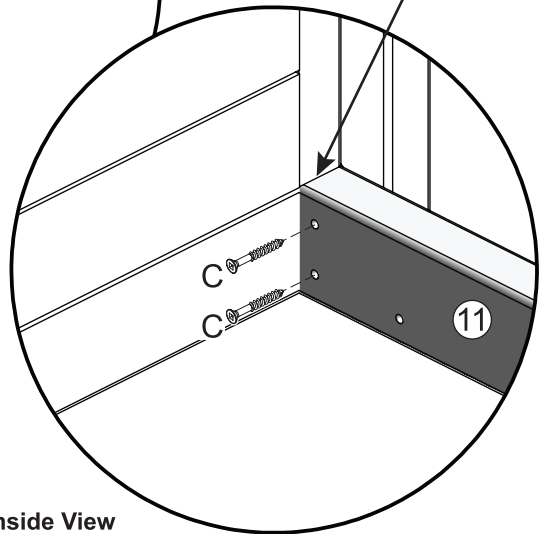

Rotated and Inside View
Vue intérieure après rotation
Vista inferior rotada
Gedrehte Innenansicht
Vista ruotata dall'interno

17

1 x 12

4 x C

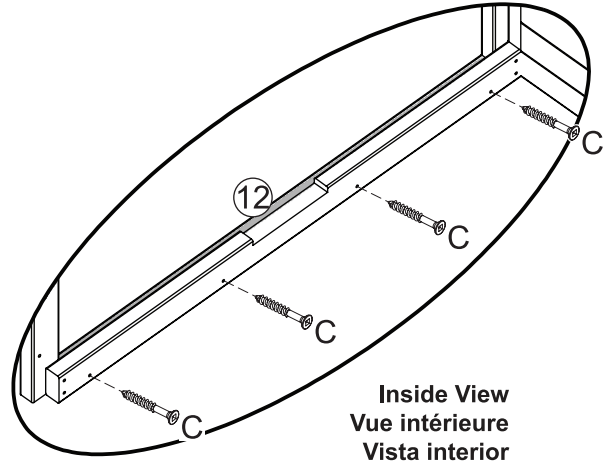
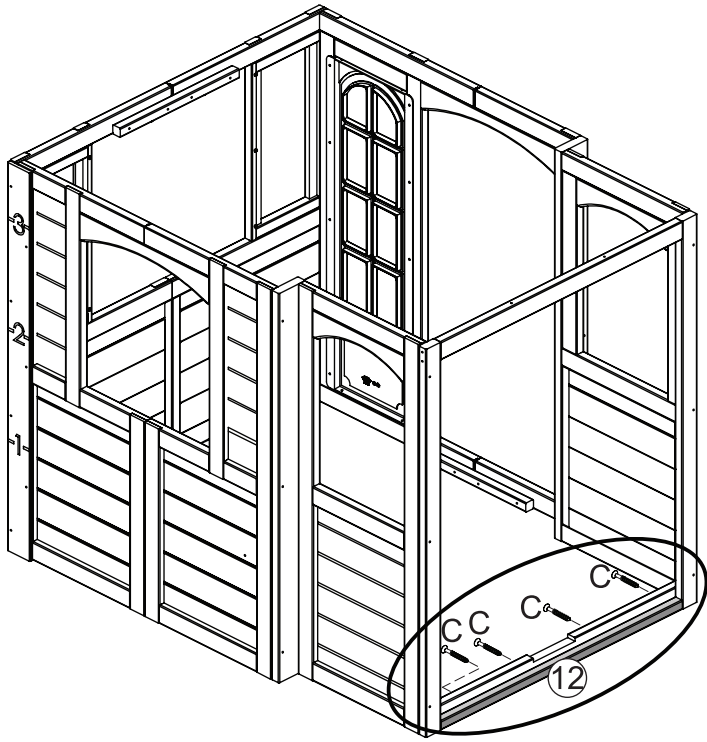

Inside View
Vue intérieure
Vista interior
Innenansicht
Vista dall'interno

18

2 x 13

4 x C

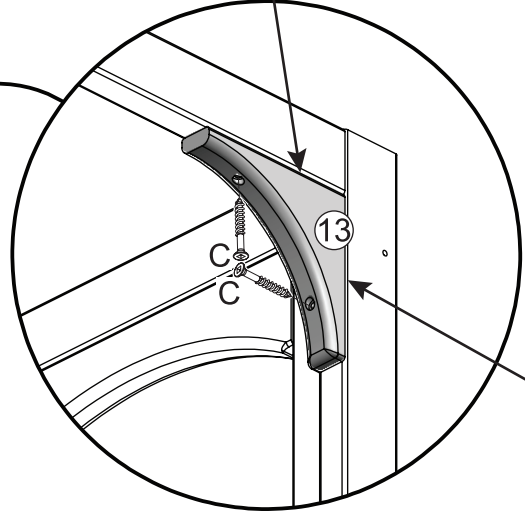
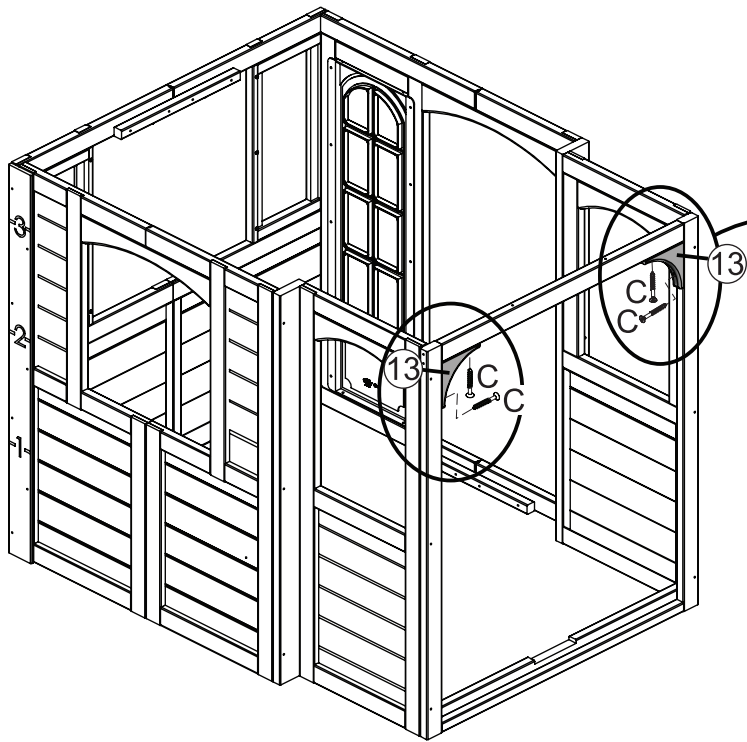

Flush
Aligné
A ras
Bündig
A filo

Flush
Aligné
A ras
Bündig
A filo

Underneath View / Vue de dessous / Vista inferior /
Unteransicht / Vista dal basso



parts.kidkraft.com

customerservice@kidkraft.com
1.800.933.0771
972.385.0100



1 x 4457C-MNRV

4 x A

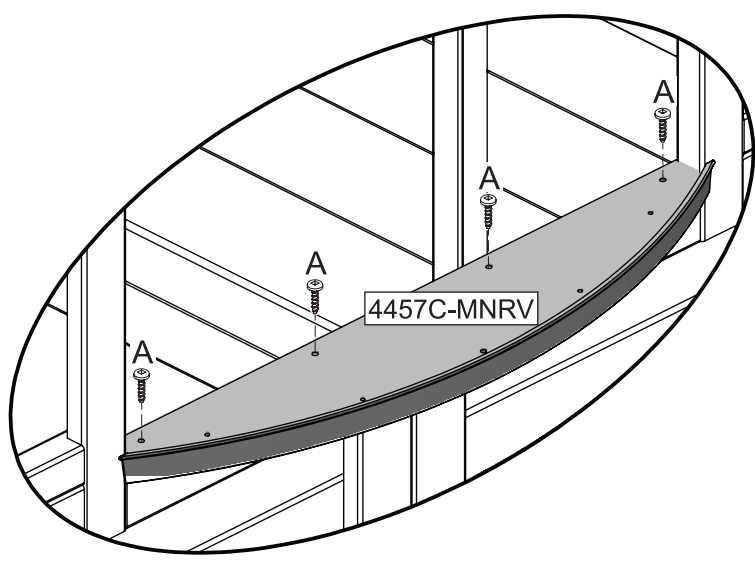
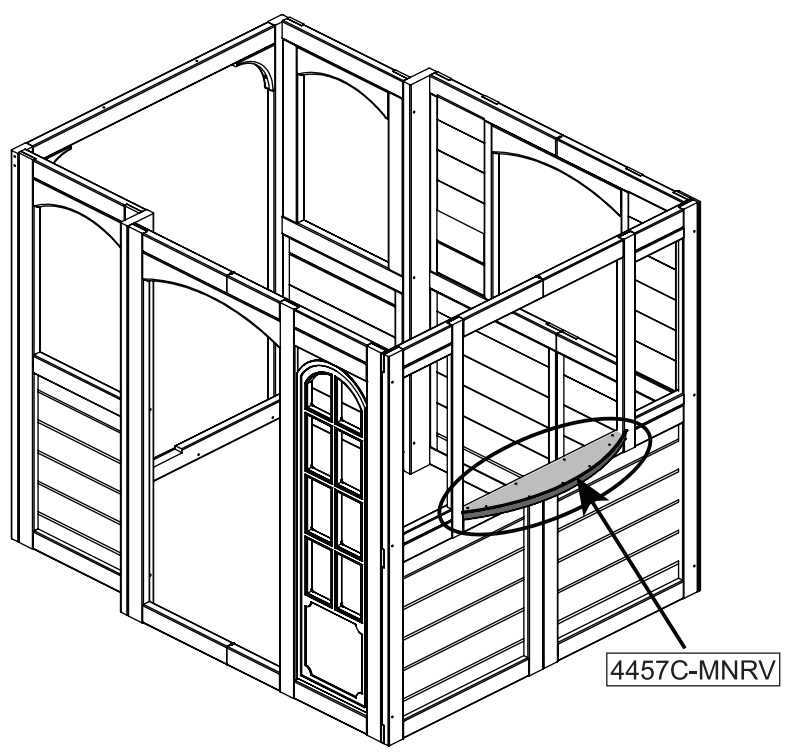



1 x 4457B-WT

10 x A

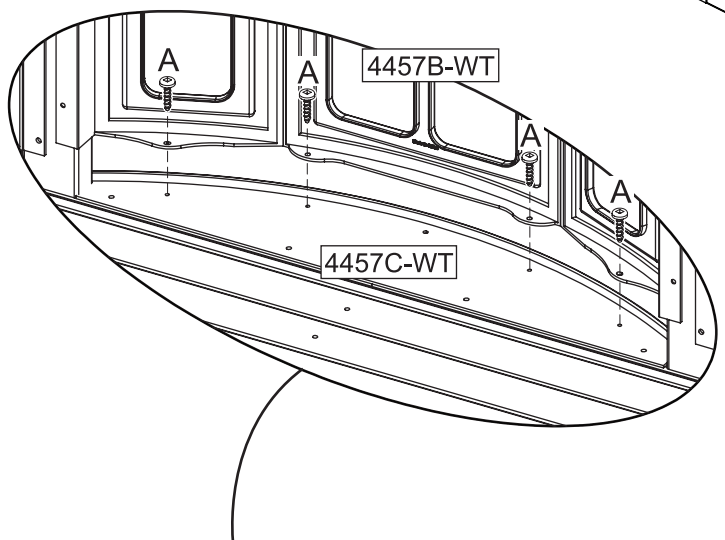
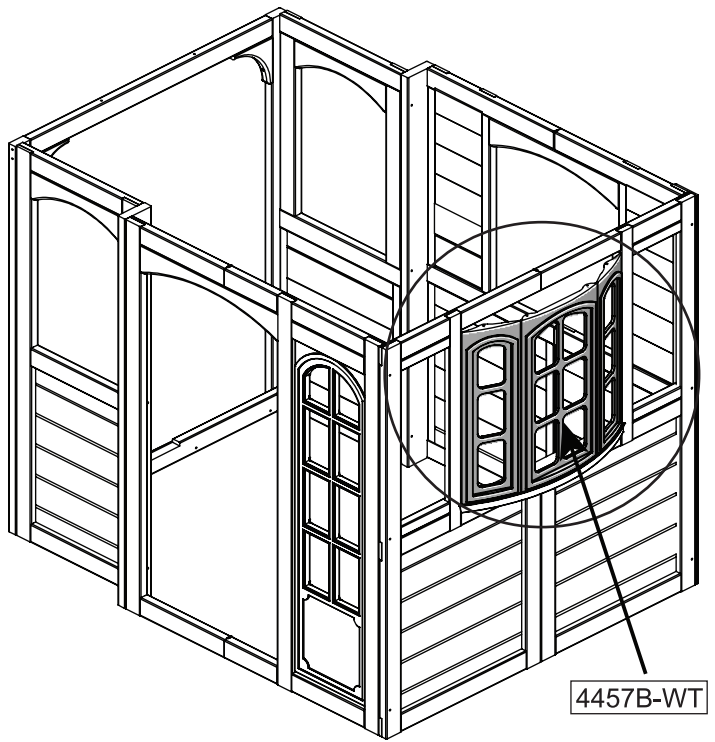

Inside View
Vue intérieure
Vista interior
Innenansicht
Vista dall'interno

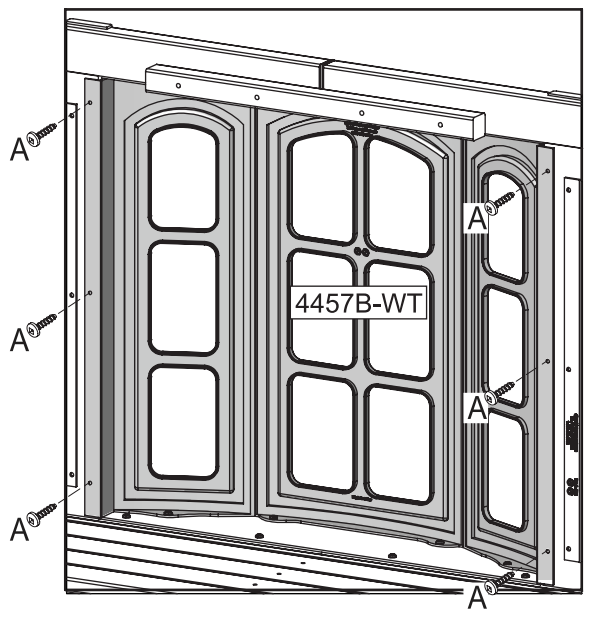
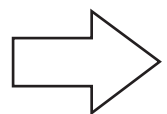
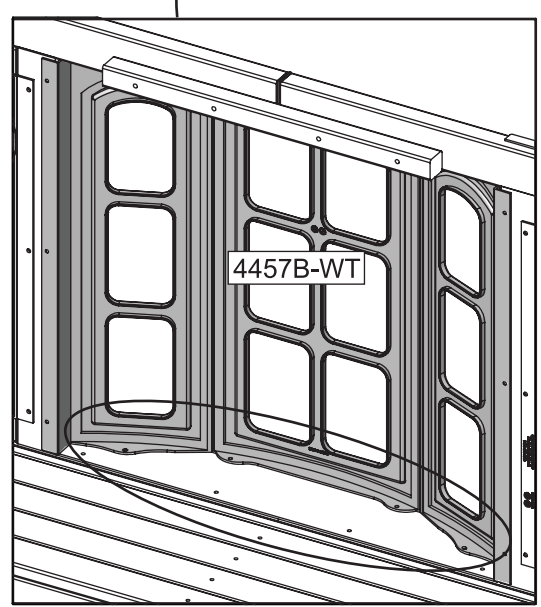

21



1 x 4457A-MNRV
8 x A

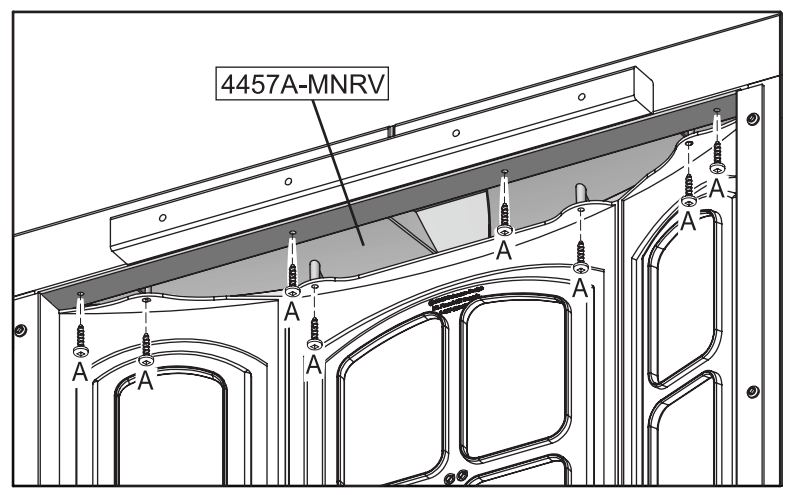
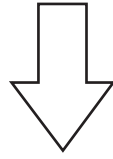
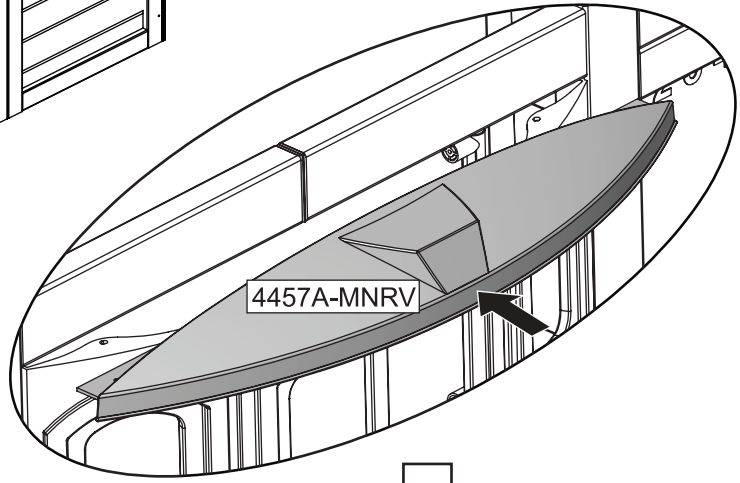
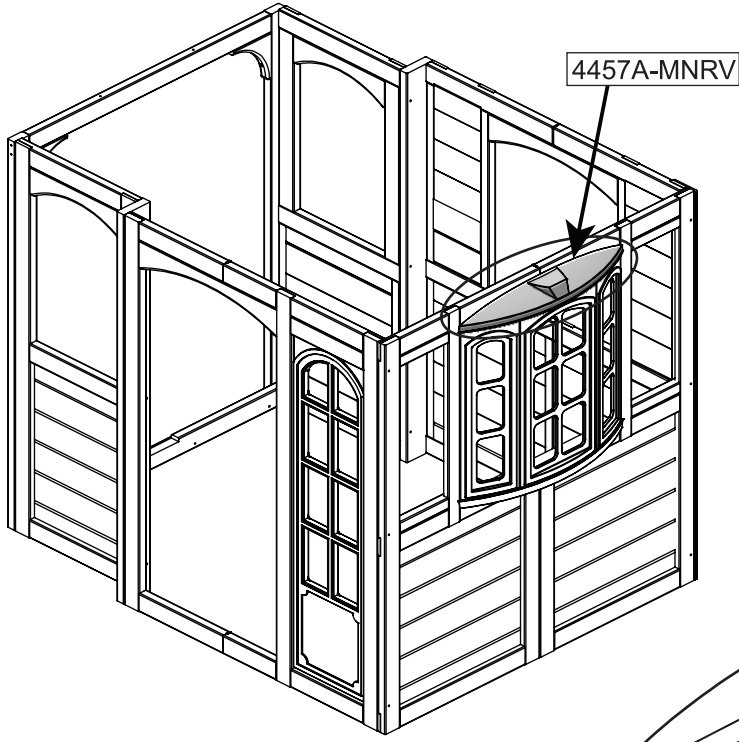

Inside View
Vue intérieure
Vista interior
Innenansicht
Vista dall'interno

22



- 1 x 4450-RD
- 1 x 4451-STGY
- 1 x 4452-STGY
- 1 x 4463-BK

2 x A

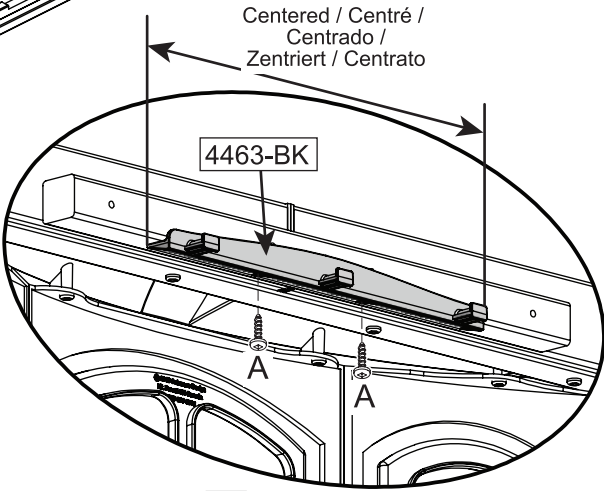
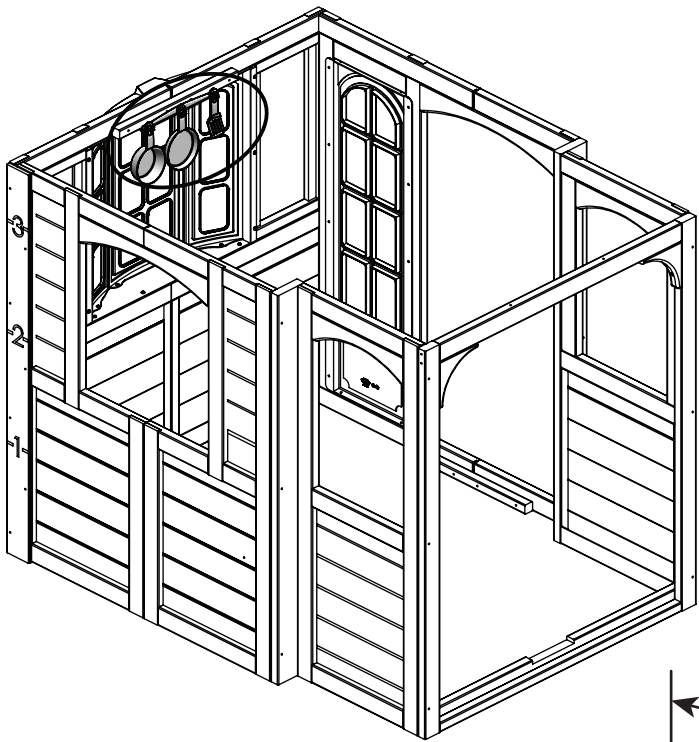

Underneath View
 Vue de dessous
 Vista inferior
 Unteransicht
 Vista dal basso

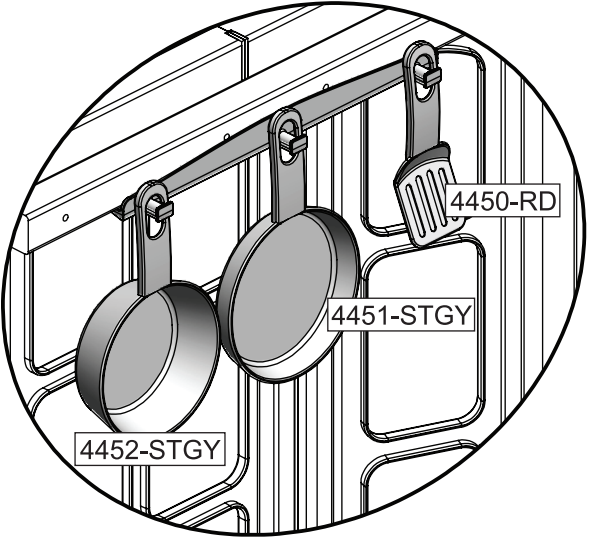
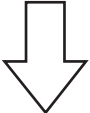

23

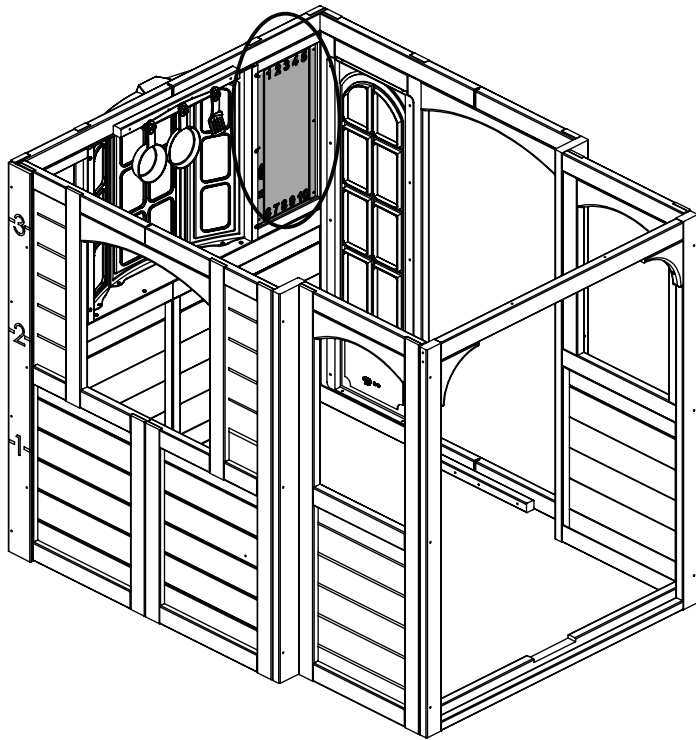

1 x 4449-BK

6 x A

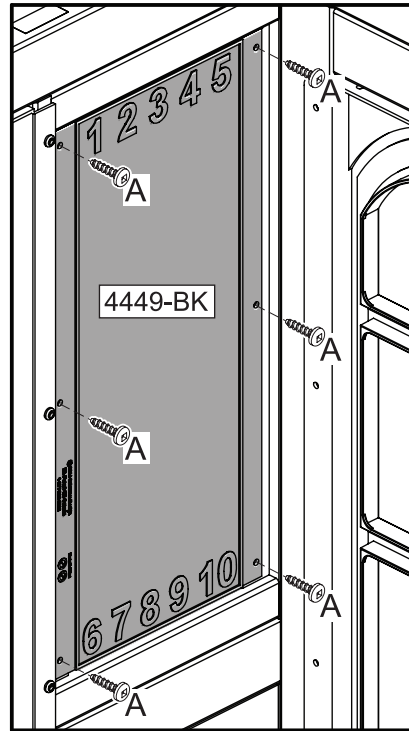

24

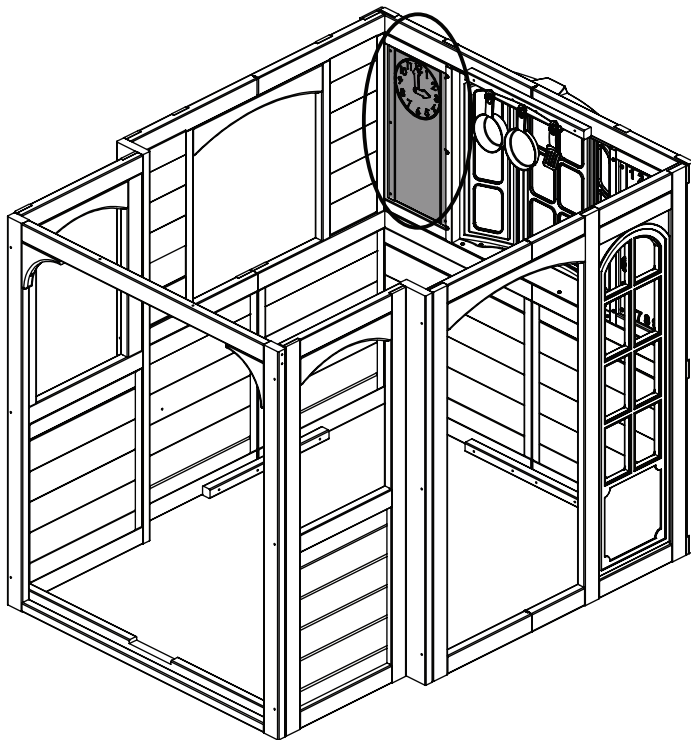

1 x 4449-BK

6 x A

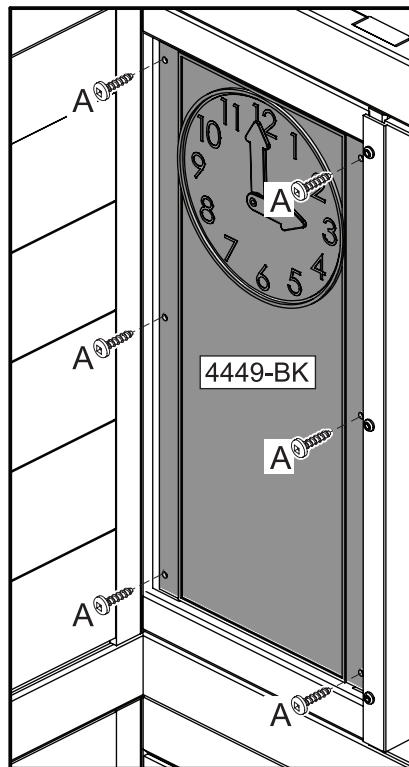

25

Notice hole orientation
 Faites attention à l'orientation des trous
 Tenga en cuenta la orientación de los orificios
 Ausrichtung der Bohrungen beachten
 Prestare attenzione all'orientamento dei fori

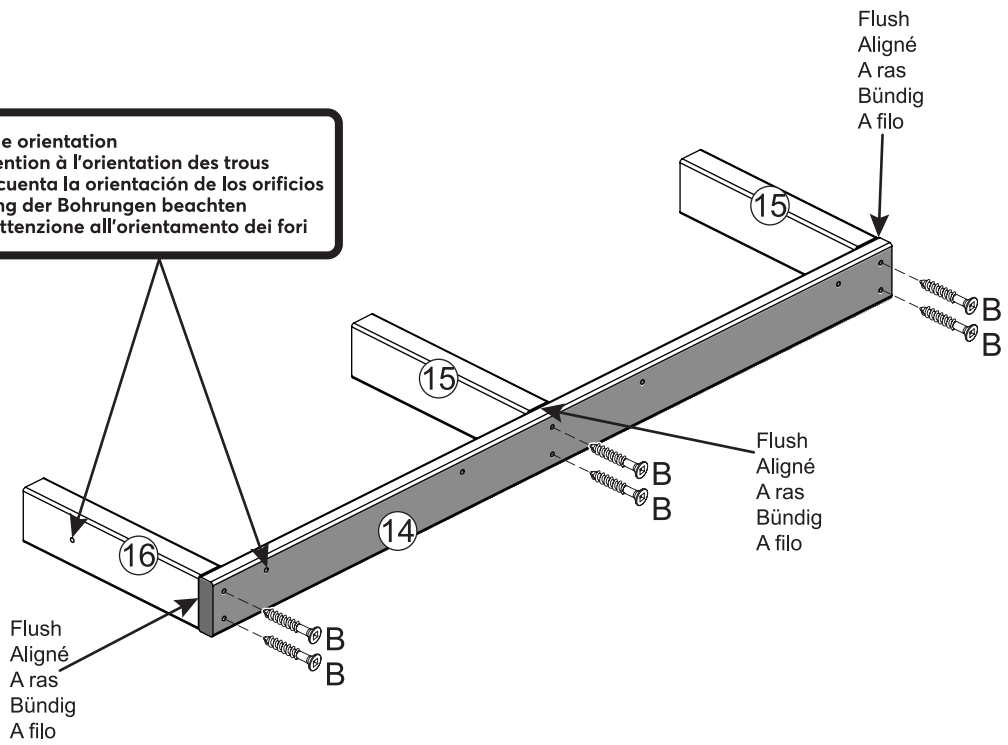

1 x 14

2 x 15

1 x 16

6 x B



26

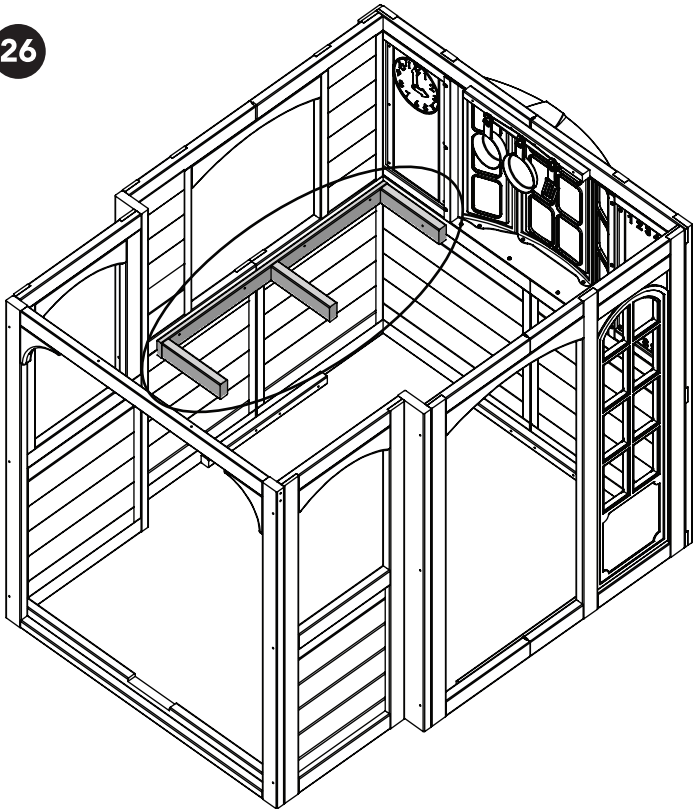

Notice hole orientation
 Faites attention à l'orientation des trous
 Tenga en cuenta la orientación de los orificios
 Ausrichtung der Bohrungen beachten
 Prestare attenzione all'orientamento dei fori

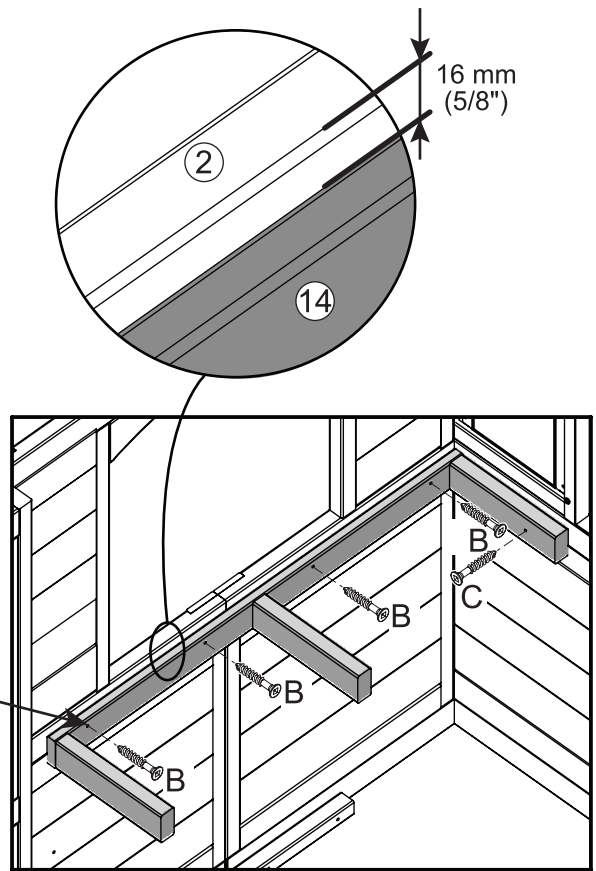

4 x B

1 x C



27

1 x 17

6 x B

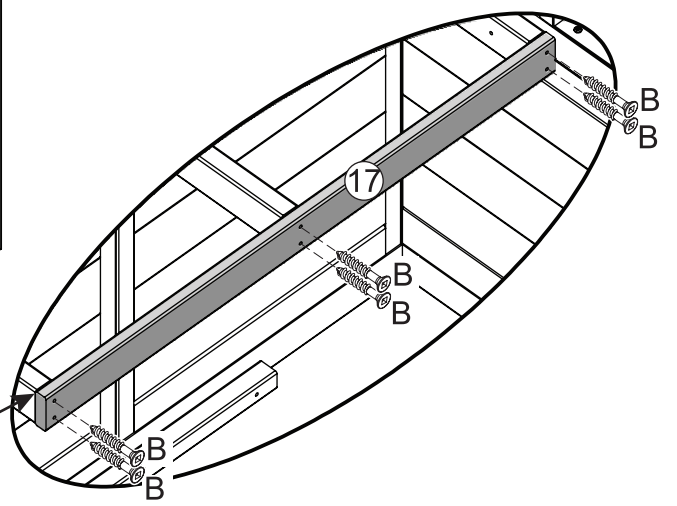
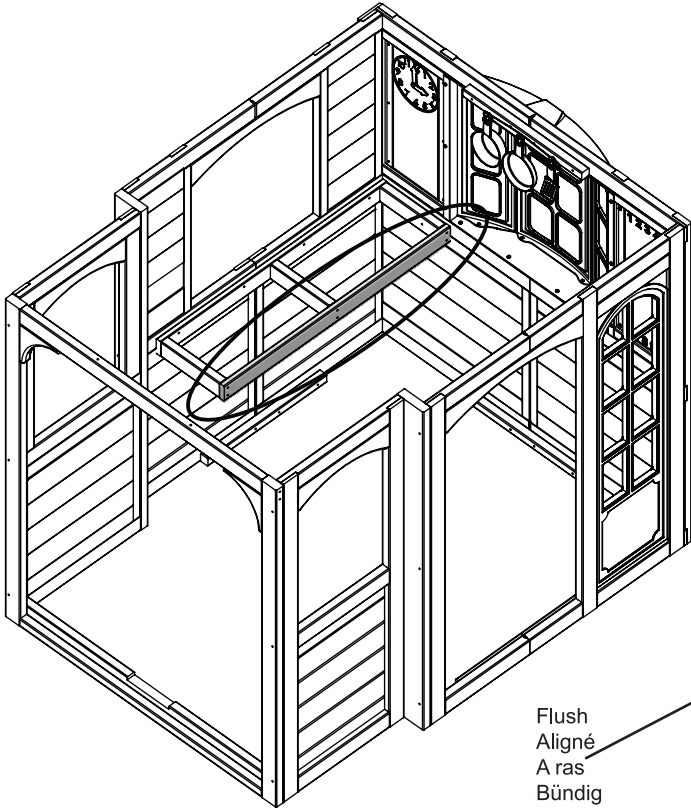

Flush
Aligné
A ras
Bündig
A filo

28

1 x 18

1 x 19

4 x D

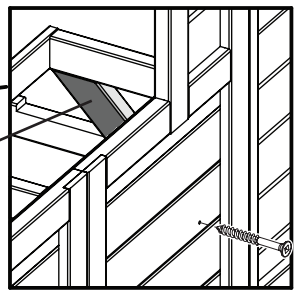
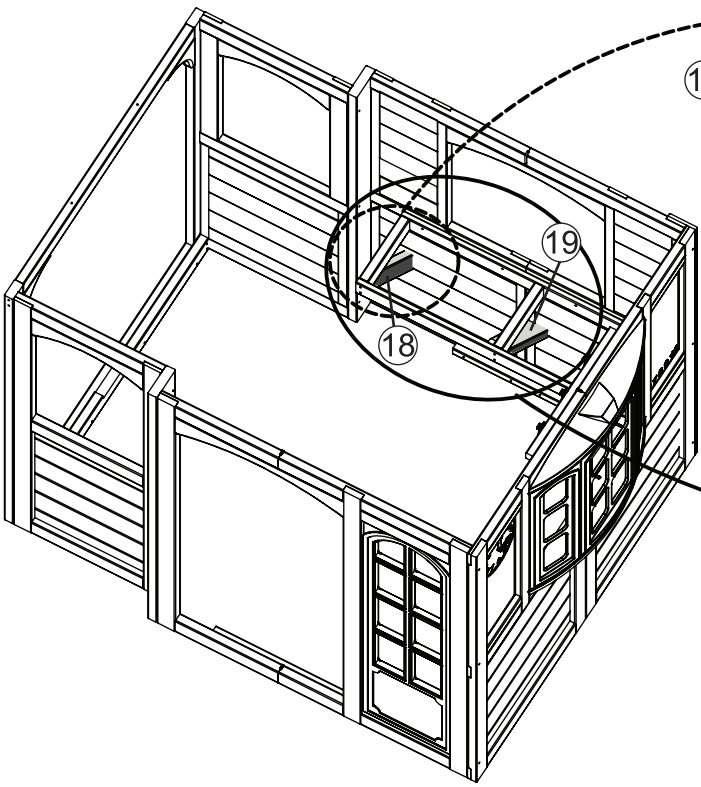

Outside View
Vue extérieure
Vista exterior
Außenansicht
Vista dall'esterno

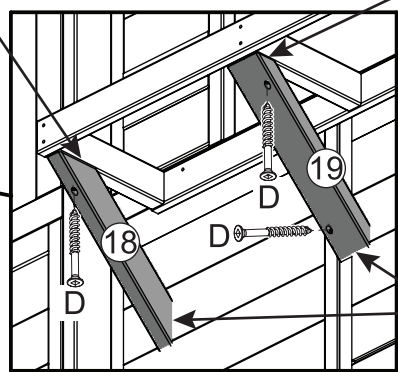

Flush
Aligné
A ras
Bündig
A filo

Flush
Aligné
A ras
Bündig
A filo

Tight
Serré
Apretado
Fest
Stretto

Underneath View / Vue de dessous /
Vista inferior / Unteransicht / Vista dal basso

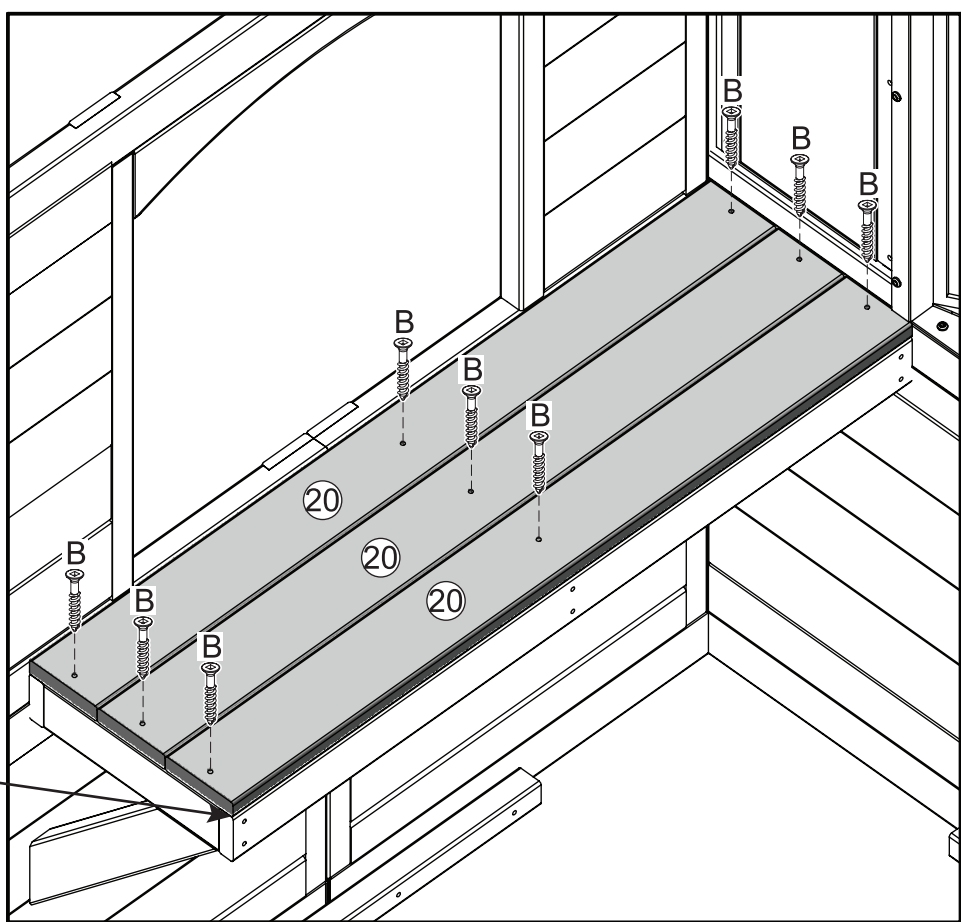
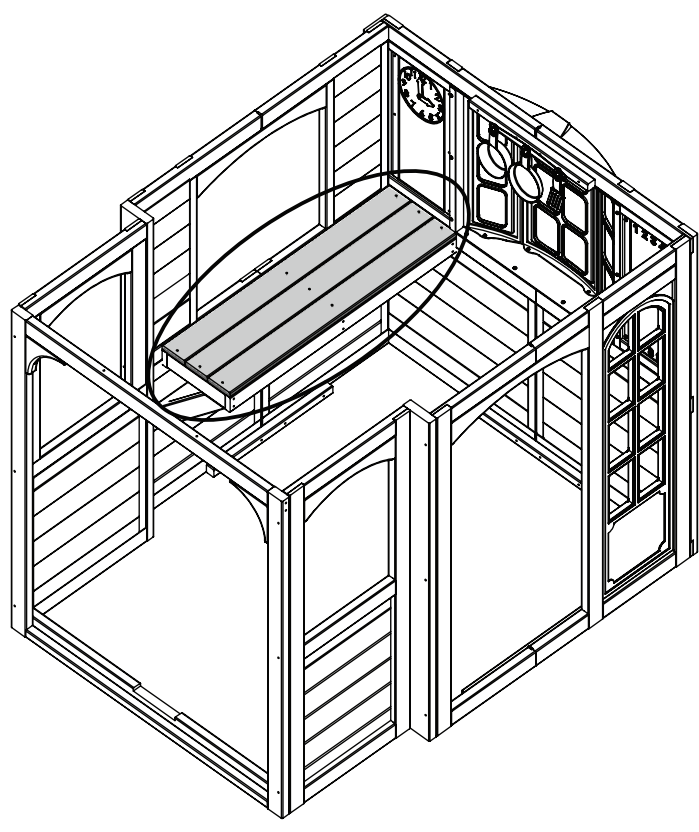

Flush
Aligné
A ras
Bündig
A filo

30

1 x 5912-a

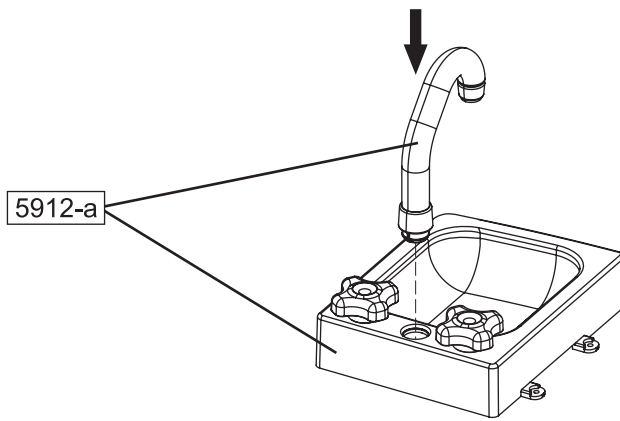

31



1 x 5912-b

6 x A

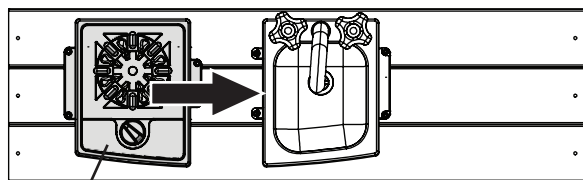
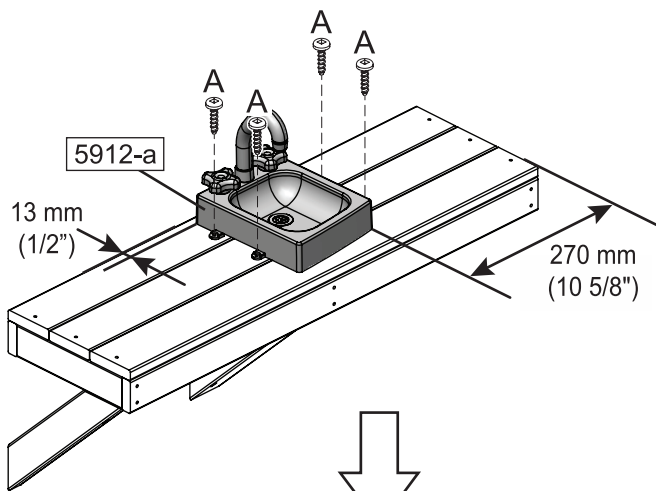

5912-b

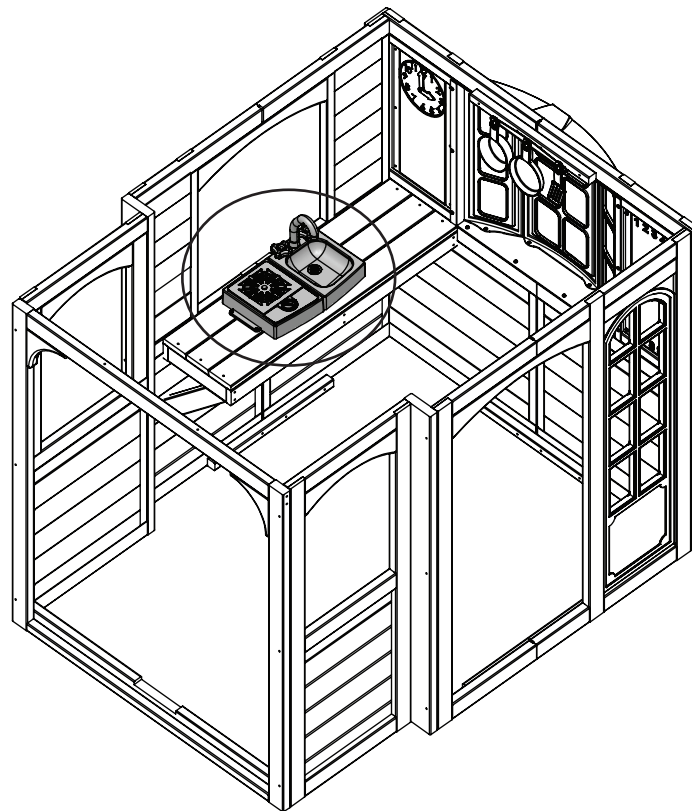
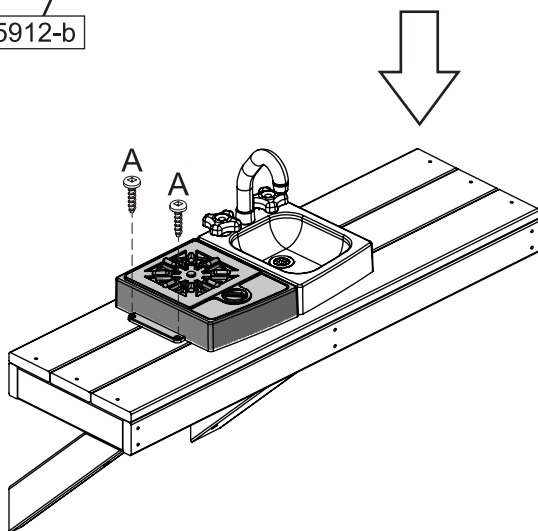

32

Note: 4459-b is flush with door edge
 Remarque : 4459-b est aligné avec le bord de la porte
 Nota: 4459-b está a ras del borde de la puerta
 Hinweis: 4459-b liegt bündig an der Türkante an
 Nota: 4459-b è a filo del margine della porta



1 x 21

1 x 4459-b

2 x A



Flush
Aligné
A ras
Bündig
A filo

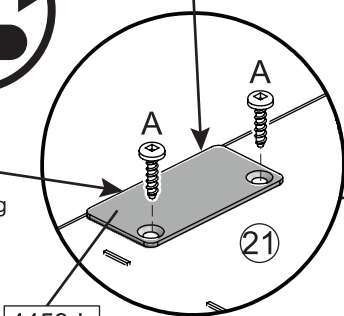

4459-b

380 mm
(15")

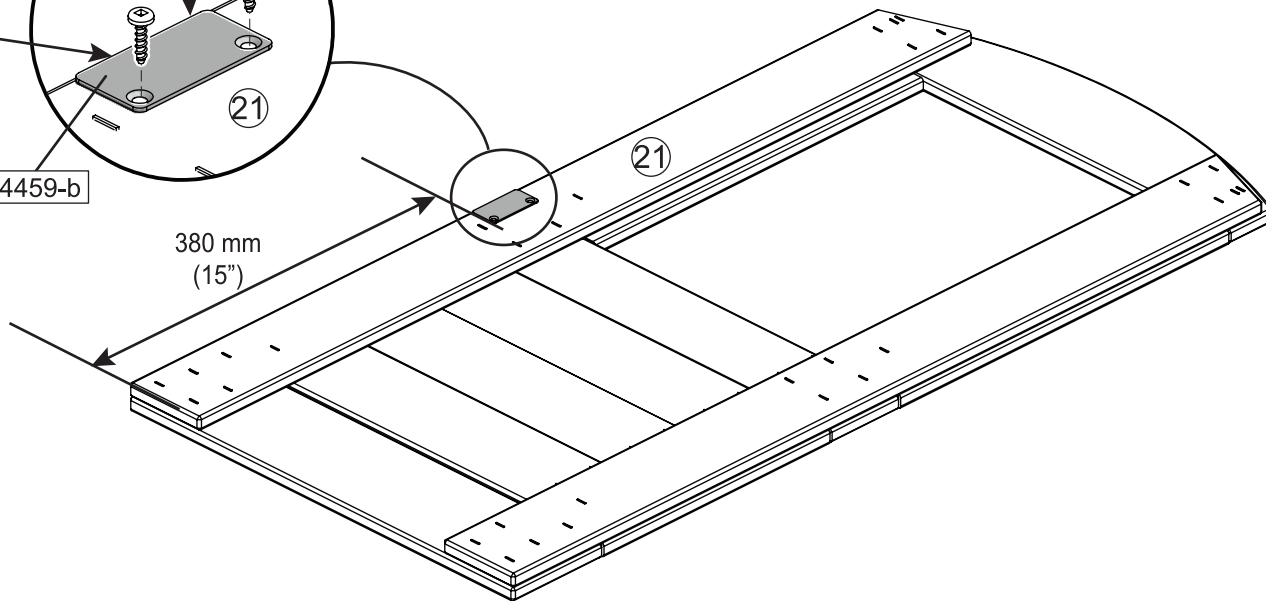

33

2 x 4465-BK

6 x A

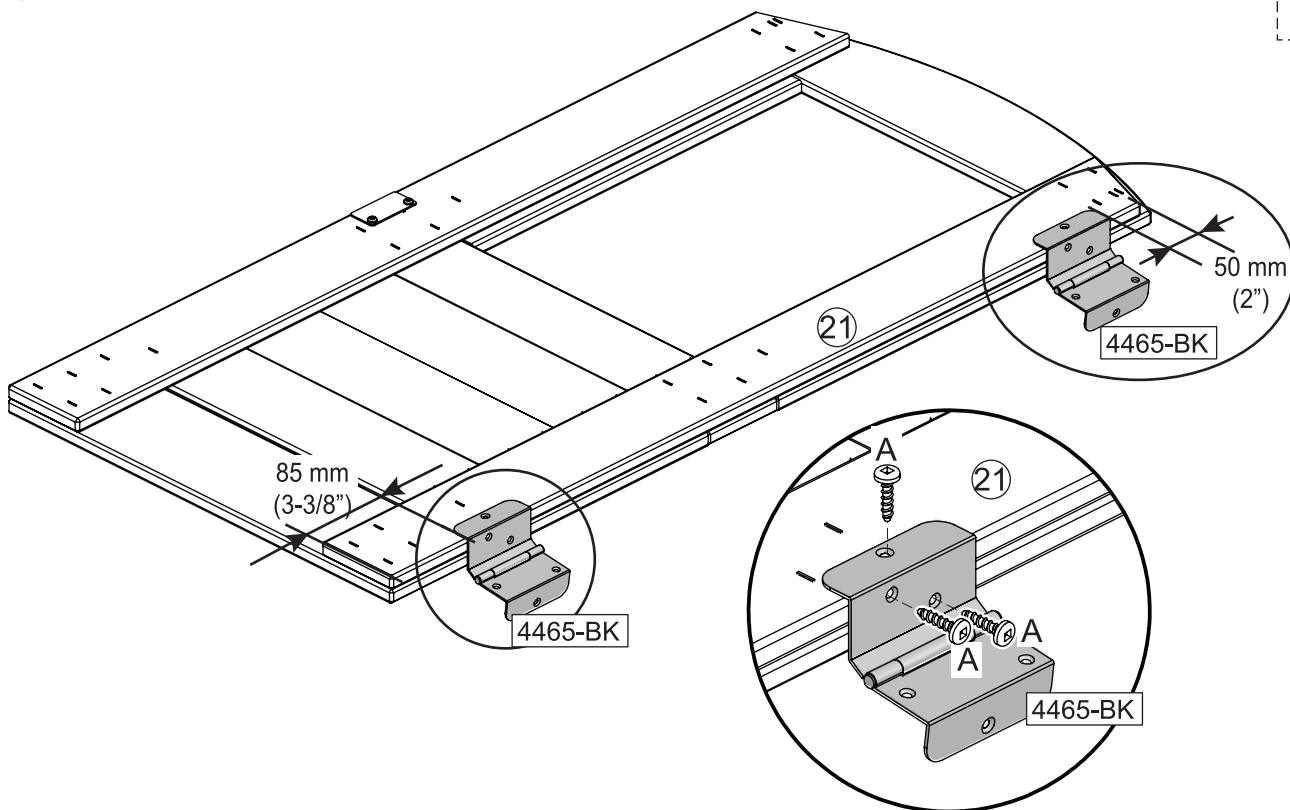

85 mm
(3-3/8")

50 mm
(2")

4465-BK

4465-BK



KidKraft
MADE FOR MAKE BELIEVE™

parts.kidkraft.com

customerservice@kidkraft.com
 1.800.933.0771
 972.385.0100

34

Important: DO NOT over tighten the Screw
 Important : NE serrez PAS TROP la vis
 Importante: NO aprietes demasiado el tornillo
 Wichtig: Ziehen Sie die Schraube NICHT zu fest an
 Importante: NON serrare eccessivamente la vite



1 x 5943-WT

4 x A

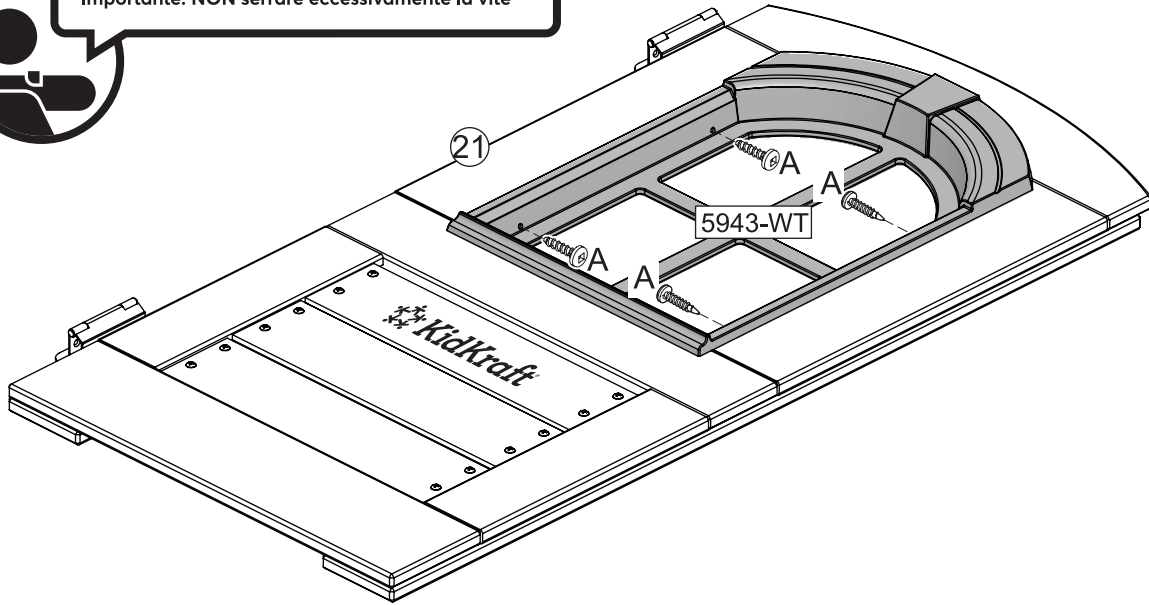

35

1 x 4458-BK

2 x A

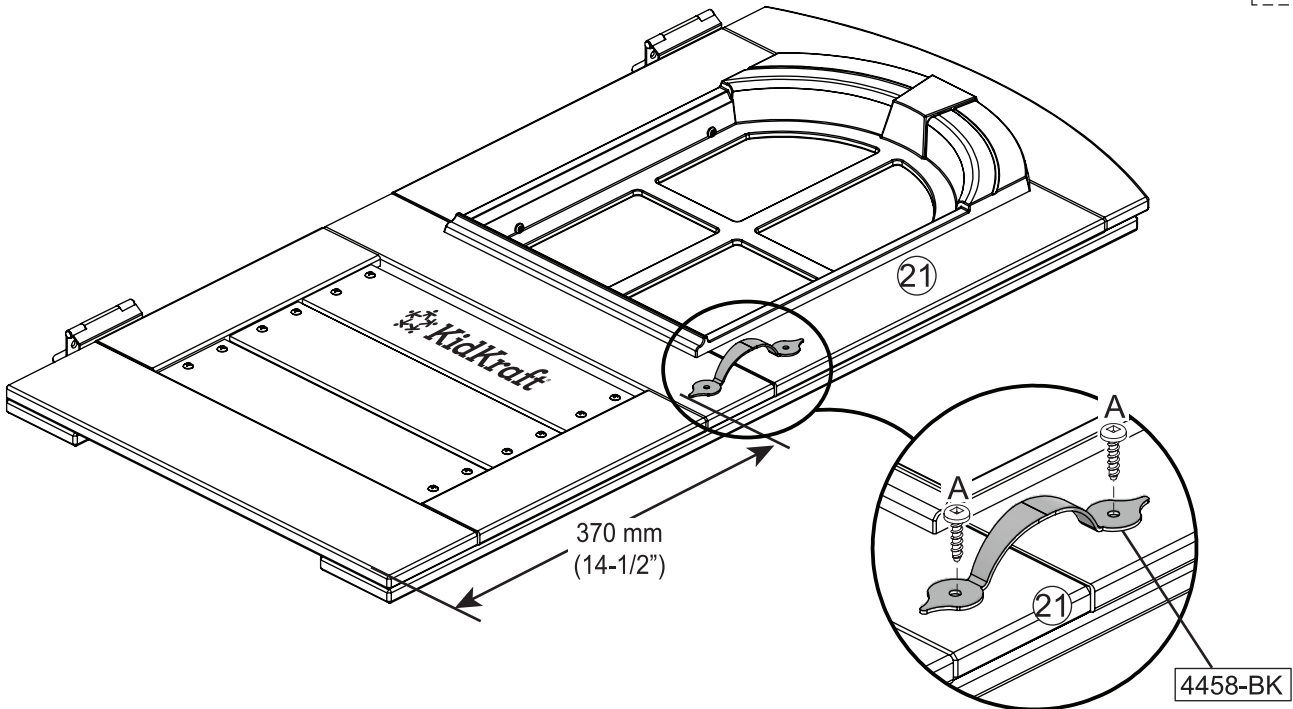

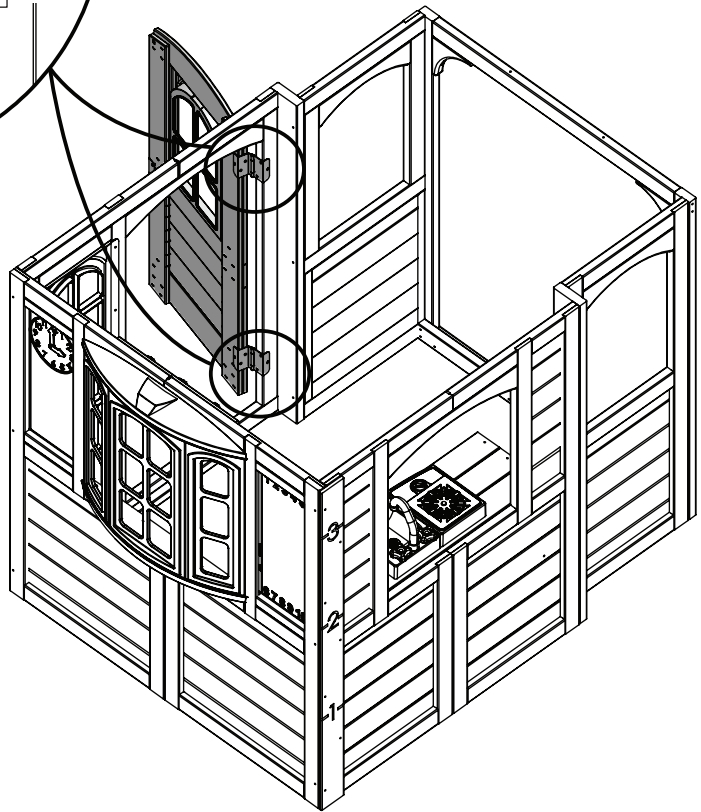
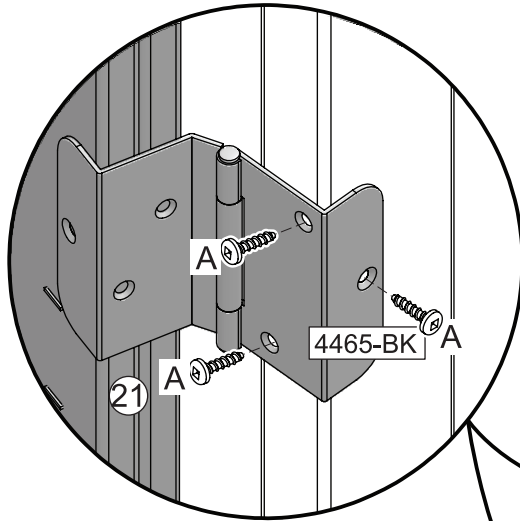

Outside View
Vue extérieure
Vista exterior
Außenansicht
Vista dall'esterno

19mm
(3/4")

37

Important: DO NOT over tighten the Screw.
 Important : NE serrez PAS TROP la vis.
 Importante: NO aprietas demasiado el tornillo.
 Wichtig: Ziehen Sie die Schraube NICHT zu fest an.
 Importante: NON serrare eccessivamente la vite.



1 x 22

1 x 4459-a

2 x F

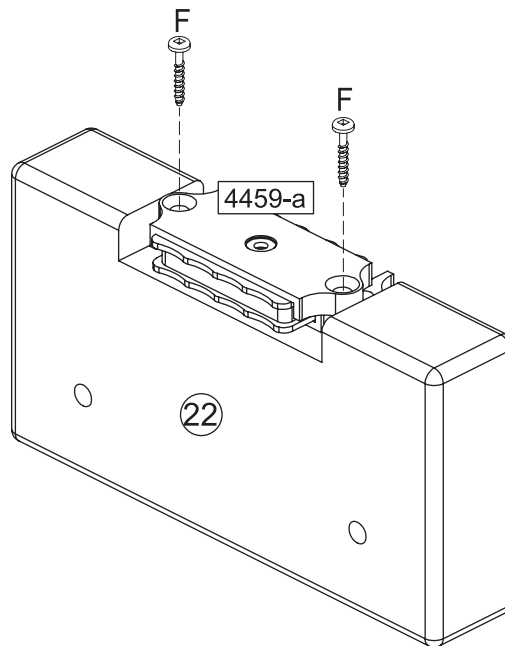

38

Note: Close door and vertically center 4459-a to 4459-b to assemble.
 Remarque : Fermer la porte et centrer verticalement 4459-a sur 4459-b pour réaliser l'assemblage.
 Nota: Cierre la puerta y centre verticalmente 4459-a con 4459-b para el montaje.
 Hinweis: Zum Zusammenbauen die Tür schließen und 4459-a vertikal an 4459-b zentrieren.
 Nota: chiudere la porta e centrare verticalmente da 4459-a a 4459-b per assemblare.



2 x C

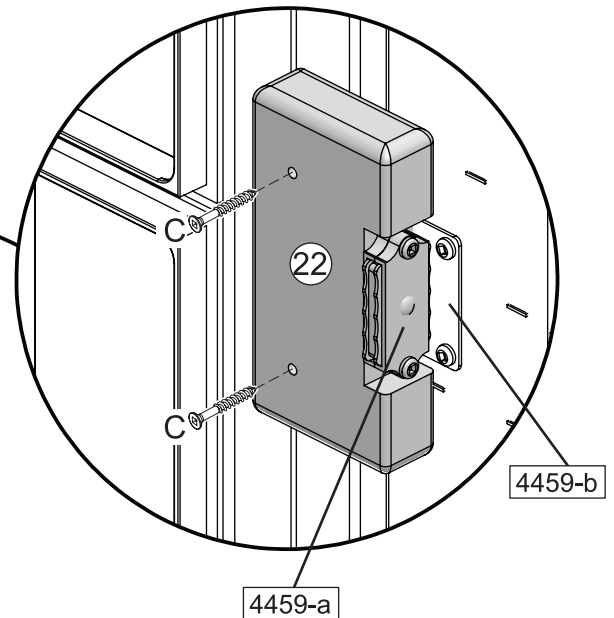
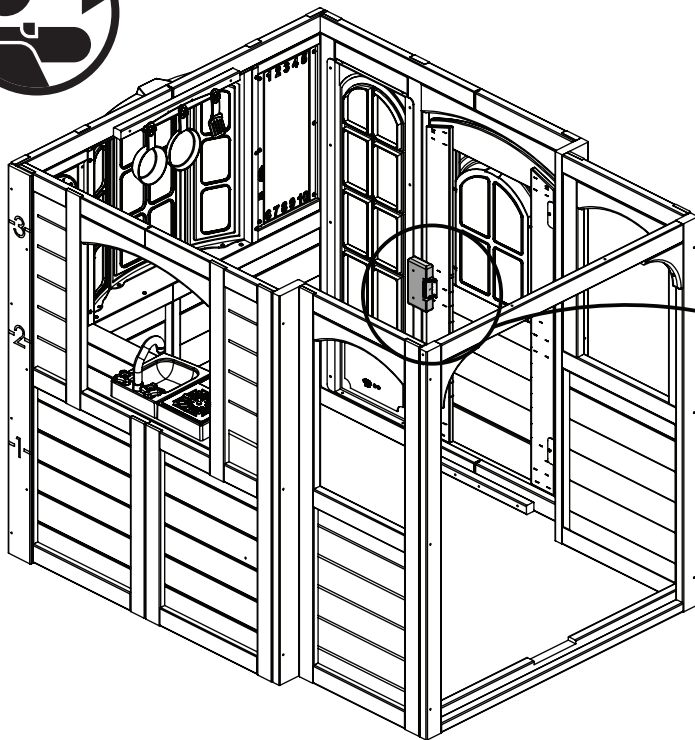



Important: DO NOT over tighten the Screw.
 Important : NE serrez PAS TROP la vis.
 Importante: NO aprietes demasiado el tornillo.
 Wichtig: Ziehen Sie die Schraube NICHT zu fest an.
 Importante: NON serrare eccessivamente la vite.

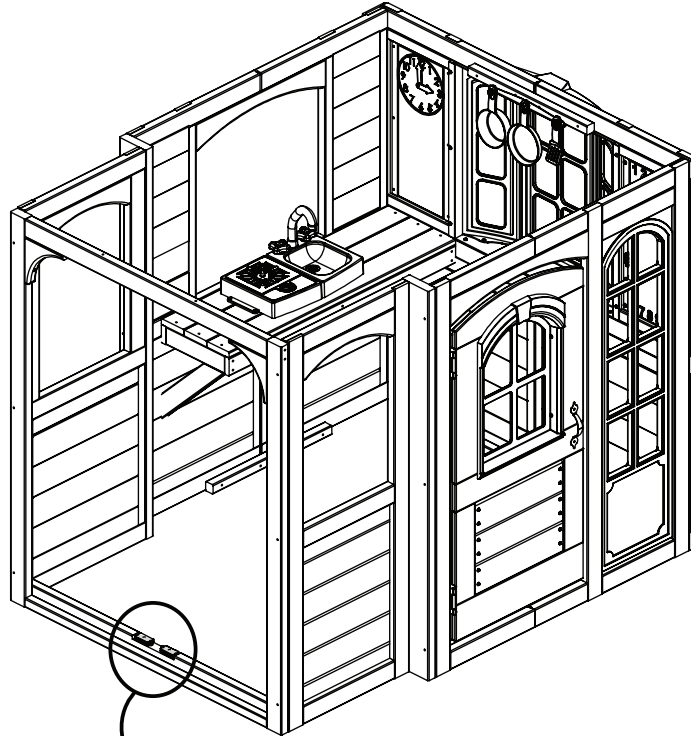

Tight / Serré /
 Apretado /
 Fest / Stretto

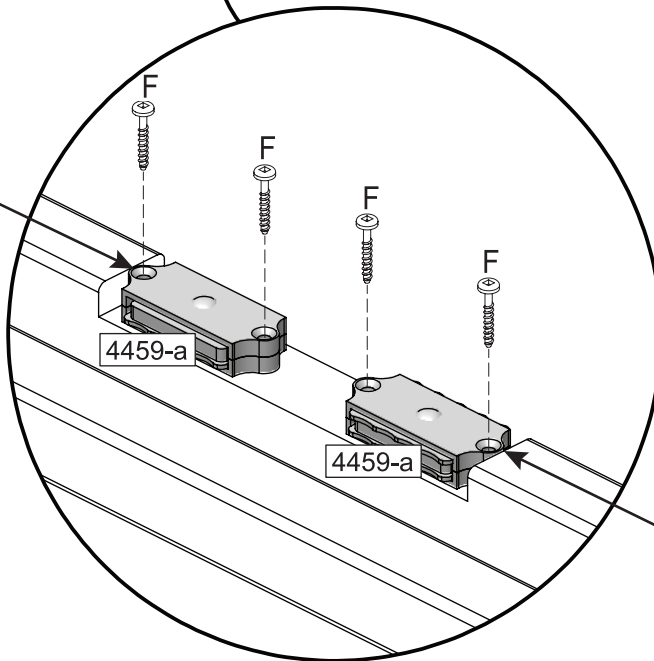

Tight / Serré /
 Apretado /
 Fest / Stretto



2 x 23

2 x 4459-b

4 x A

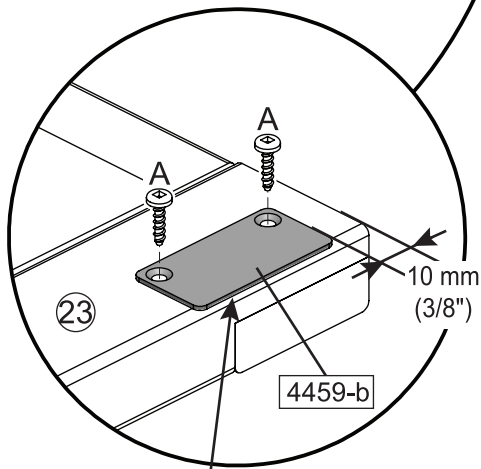
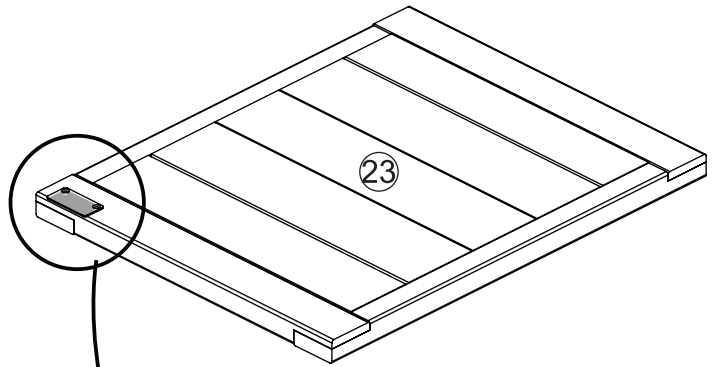
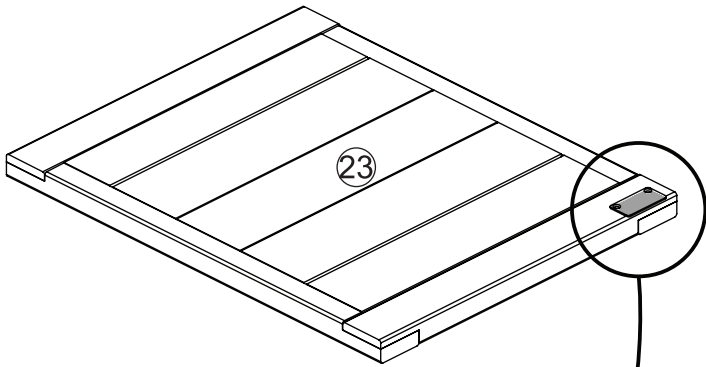

Flush
Aligné
A ras
Bündig
A filo

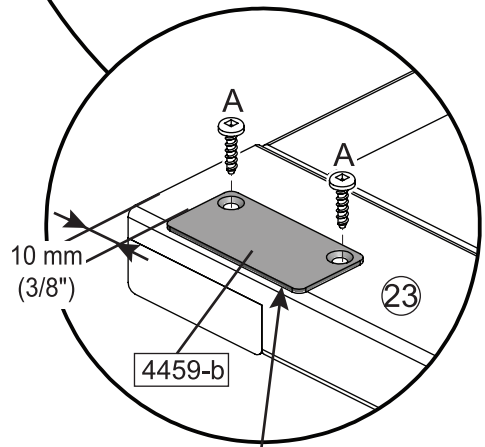

Flush
Aligné
A ras
Bündig
A filo



Flush
Aligné
A ras
Bündig
A filo

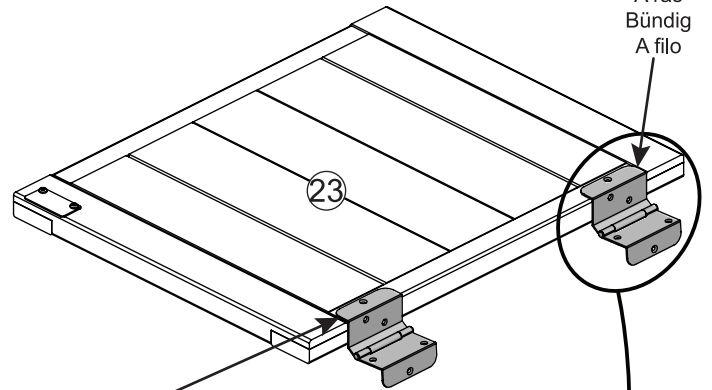
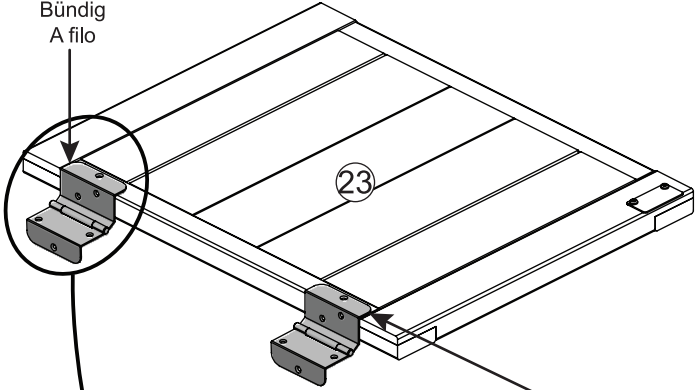

Flush
Aligné
A ras
Bündig
A filo

Flush
Aligné
A ras
Bündig
A filo

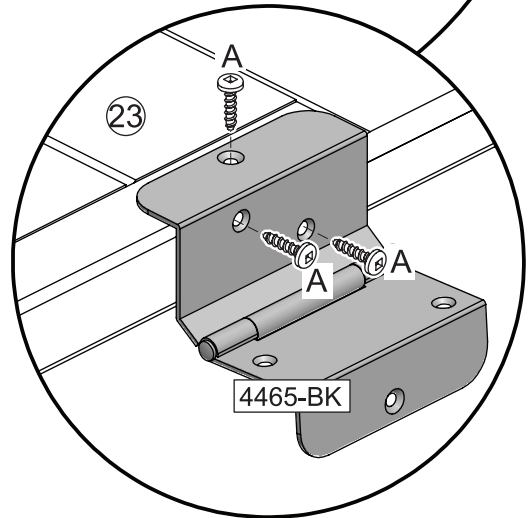
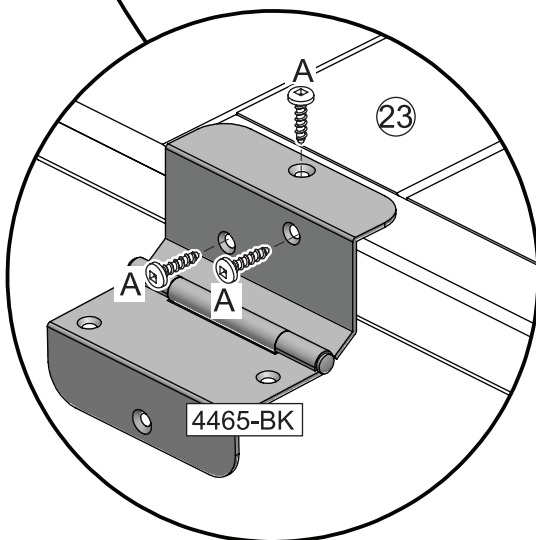

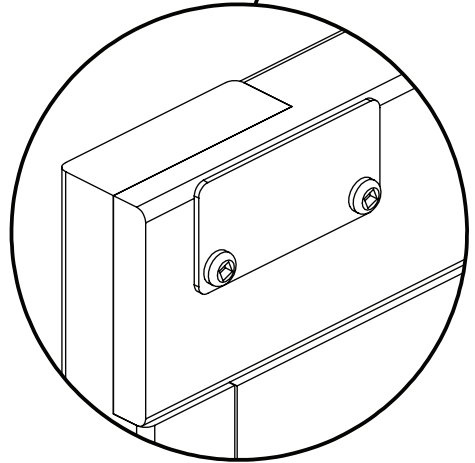
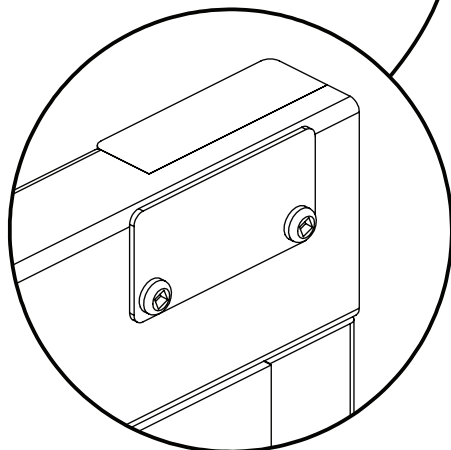
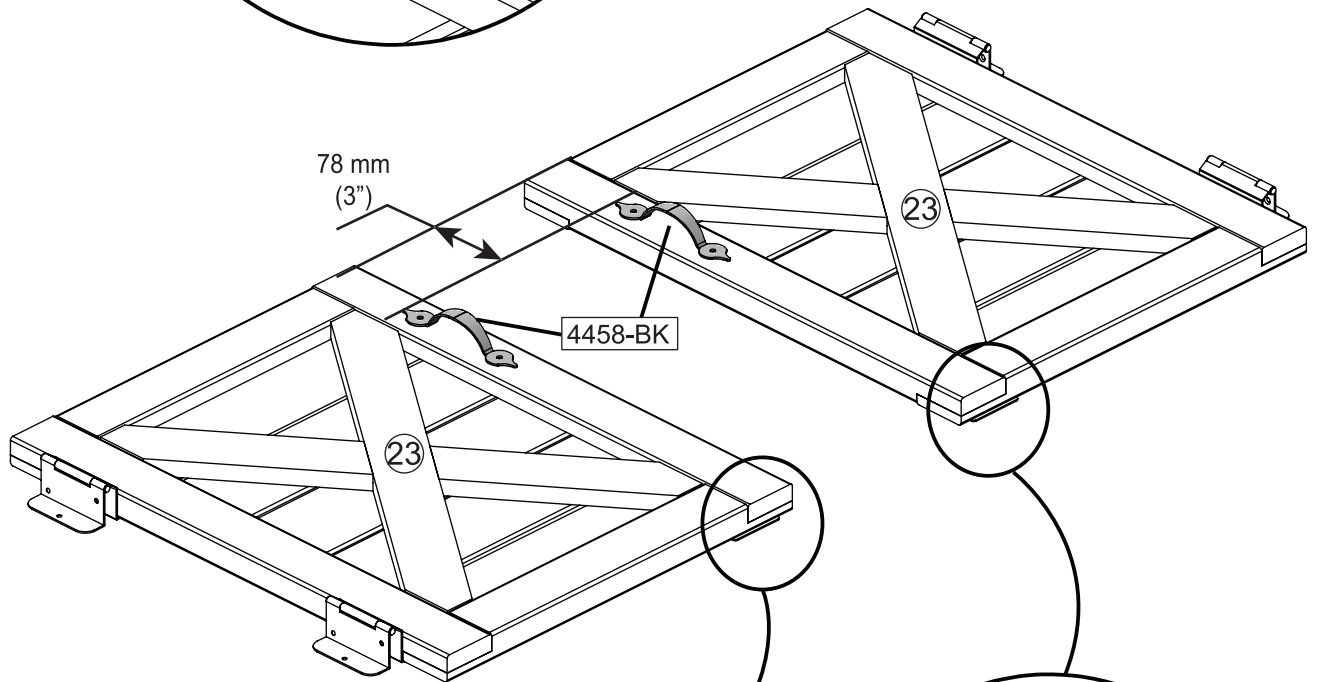
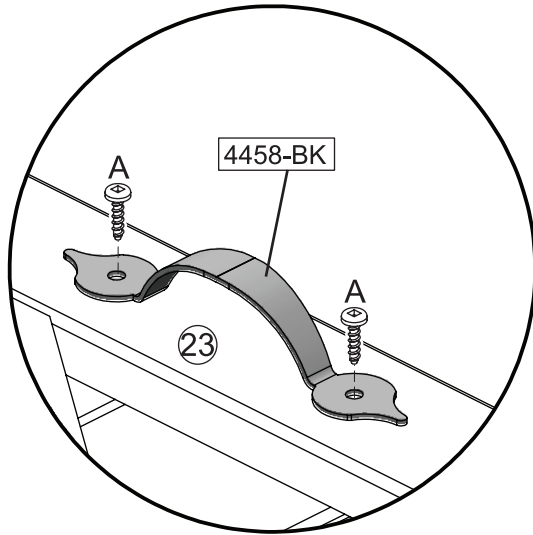

Underneath View / Vue de dessous / Vista inferior /
Unteransicht / Vista dal basso



2 x 4607-MNRV

2 x A

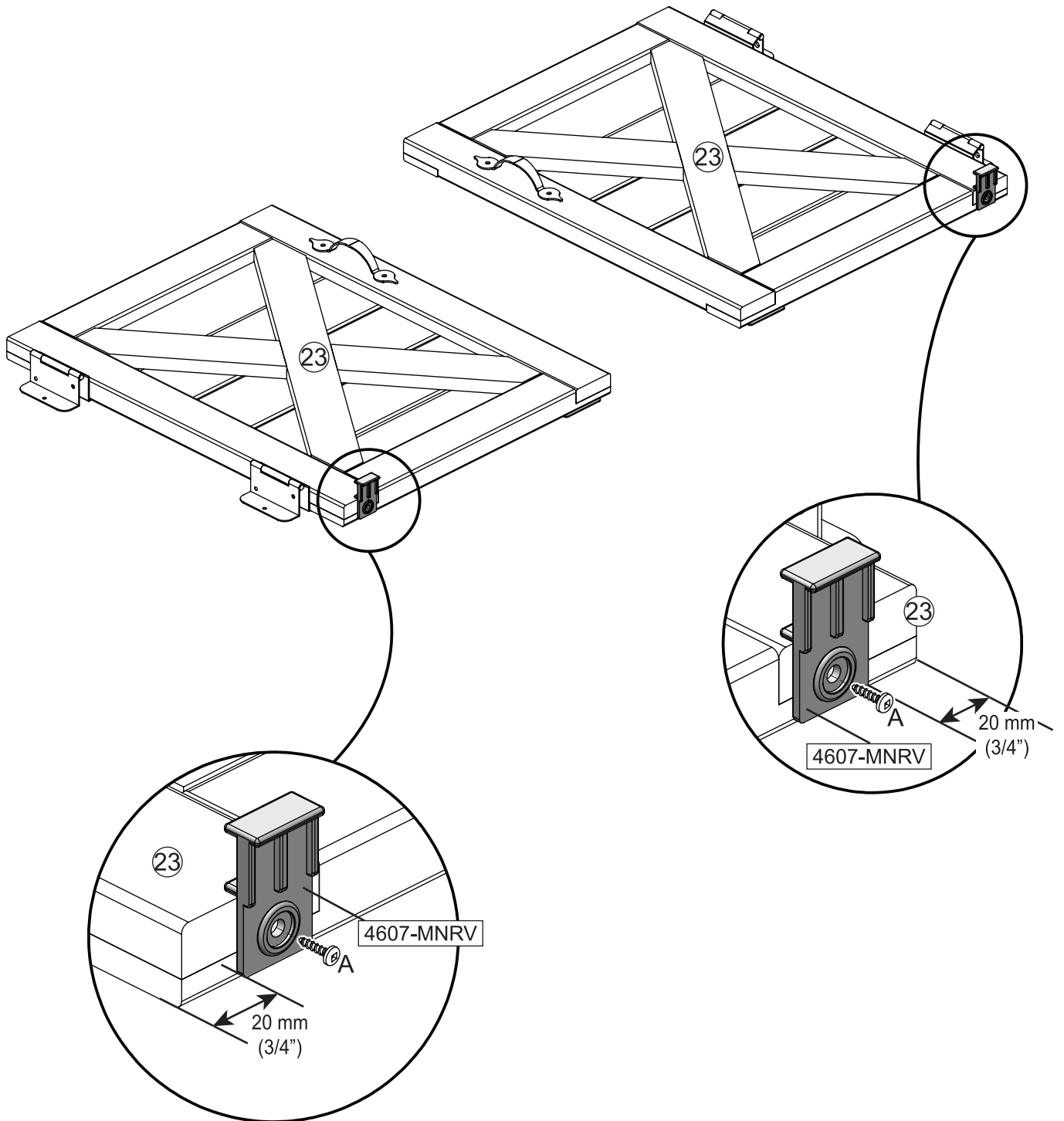

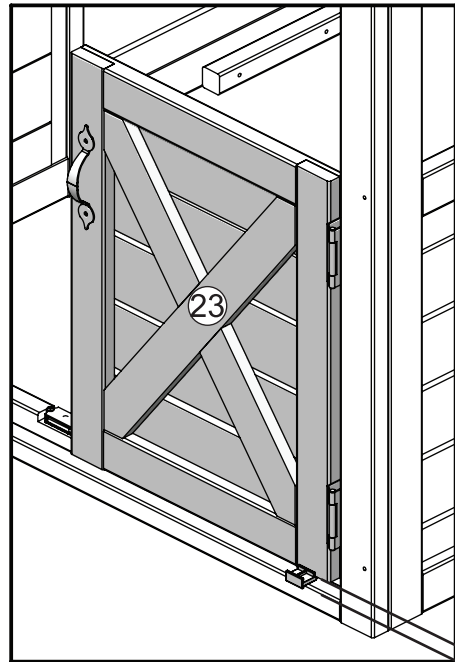
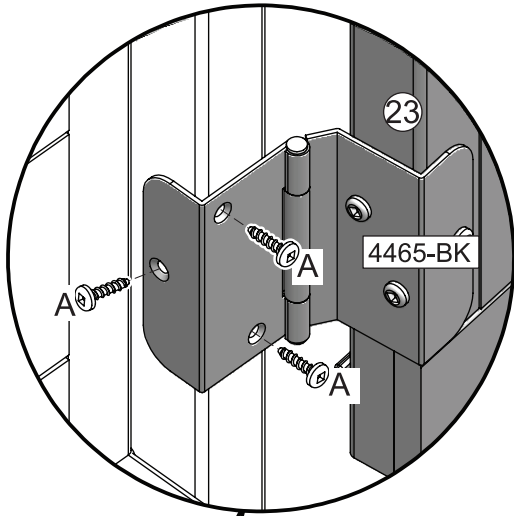

16mm
(5/8")

Outside View
Vue extérieure
Vista exterior
Außenansicht
Vista dall'esterno

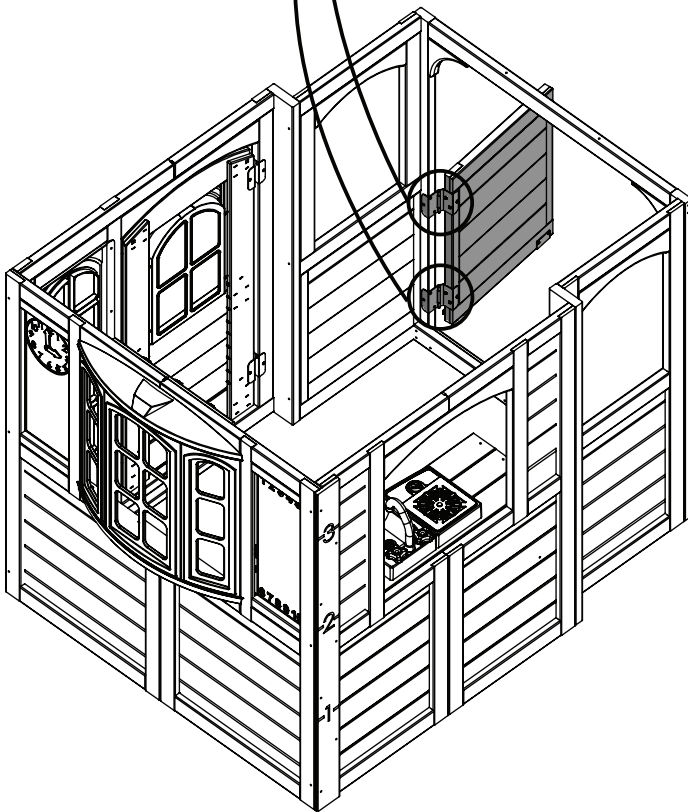

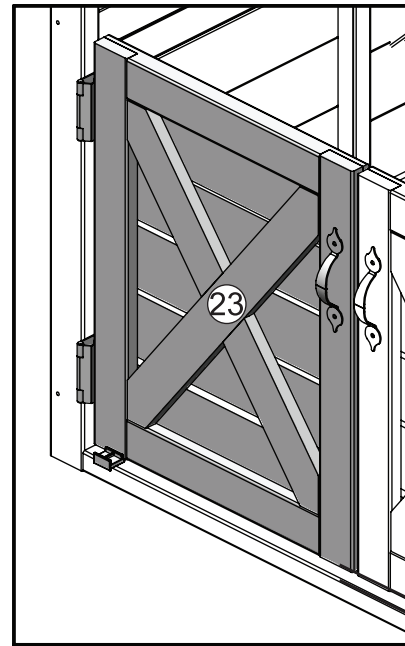
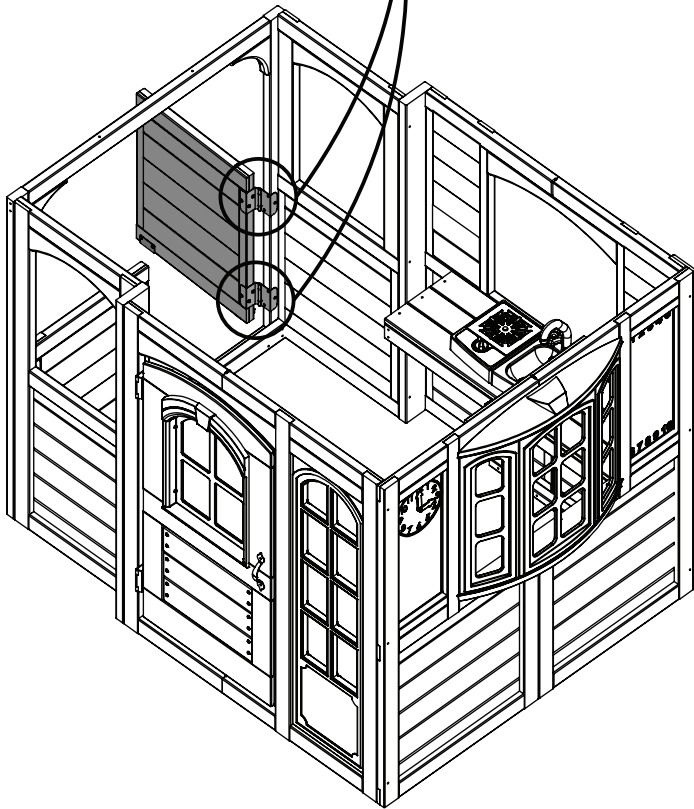
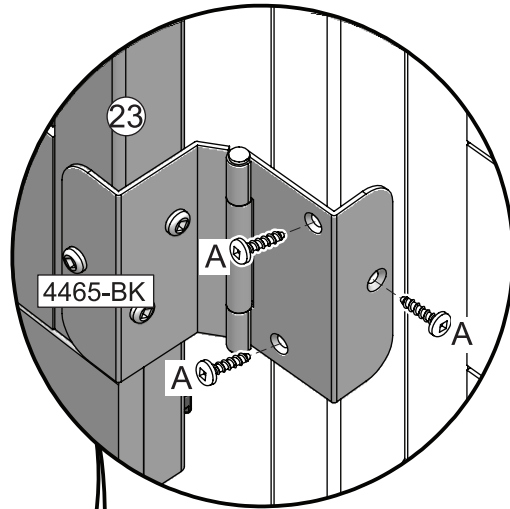

16mm
(5/8")

Outside View
Vue extérieure
Vista exterior
Außenansicht
Vista dall'esterno

46



2 x 24

1 x E

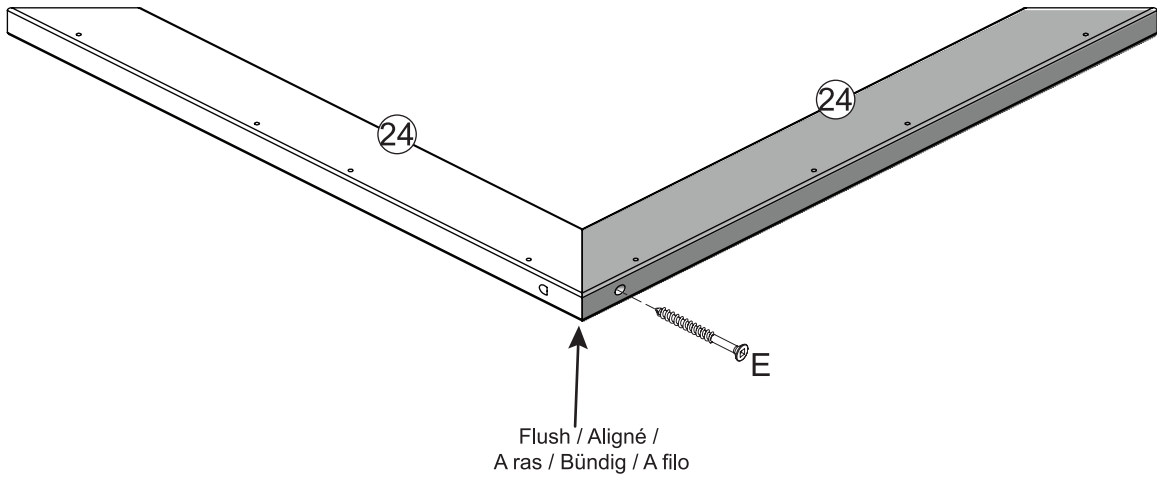

47

2 x 25

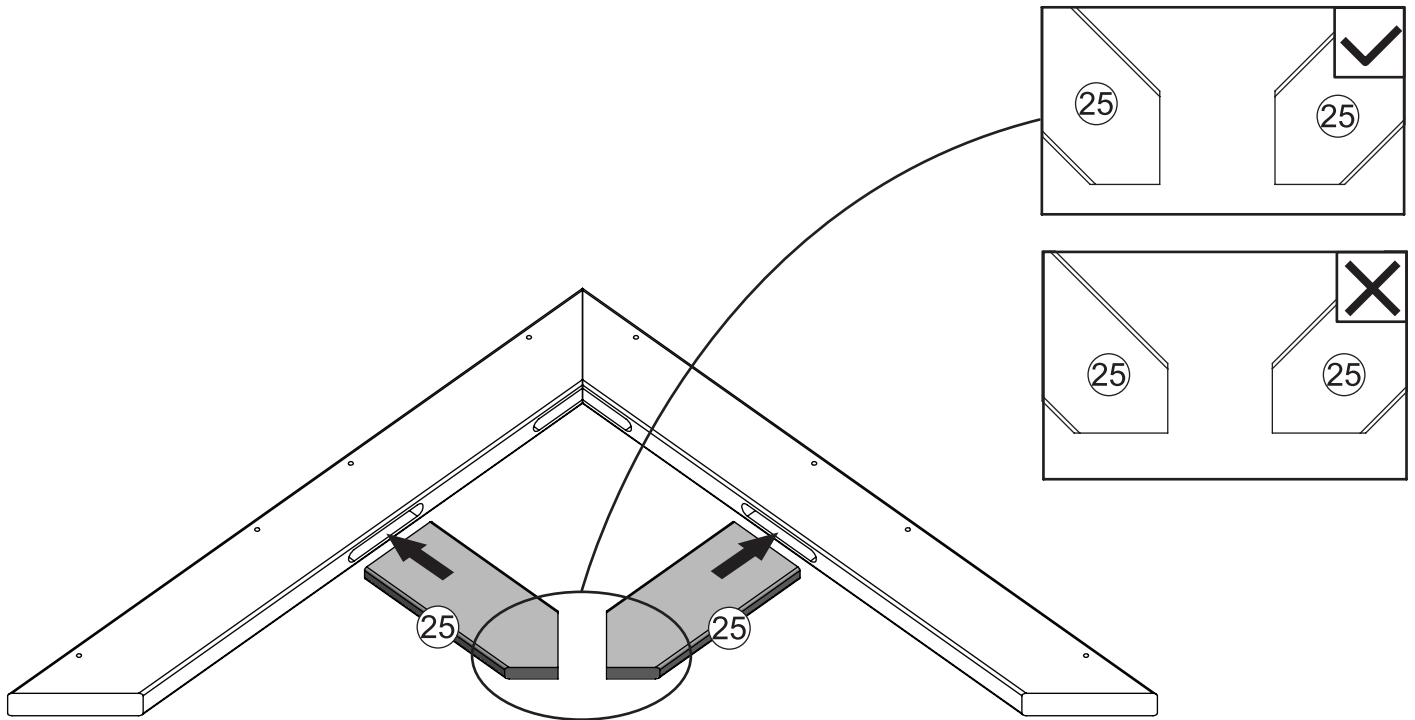

48

1 x 26

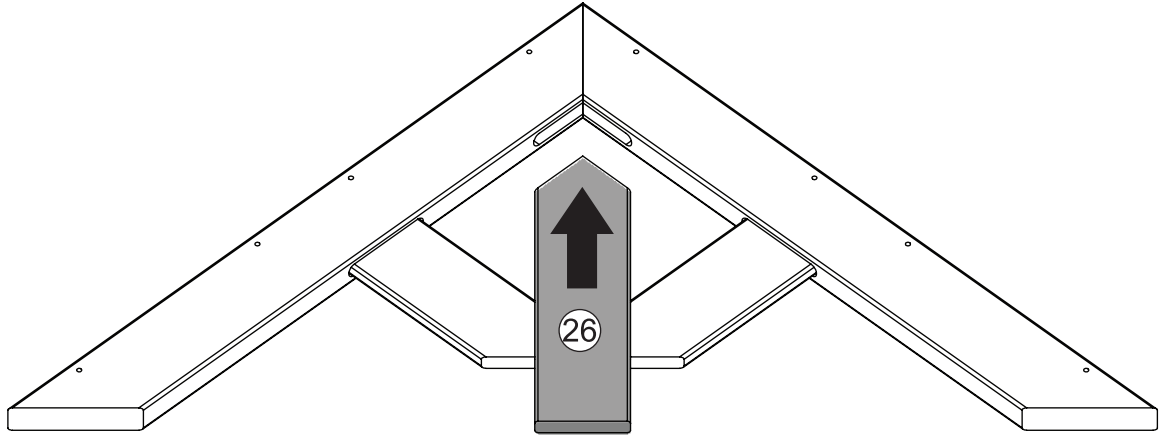

49

1 x 27

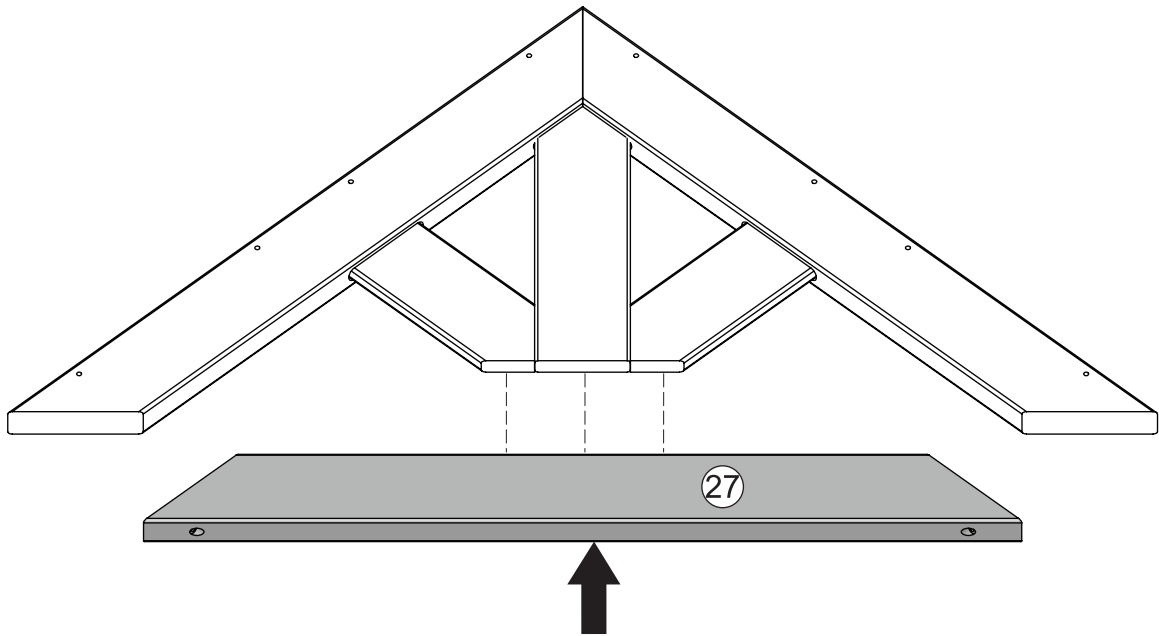

50

2 x E

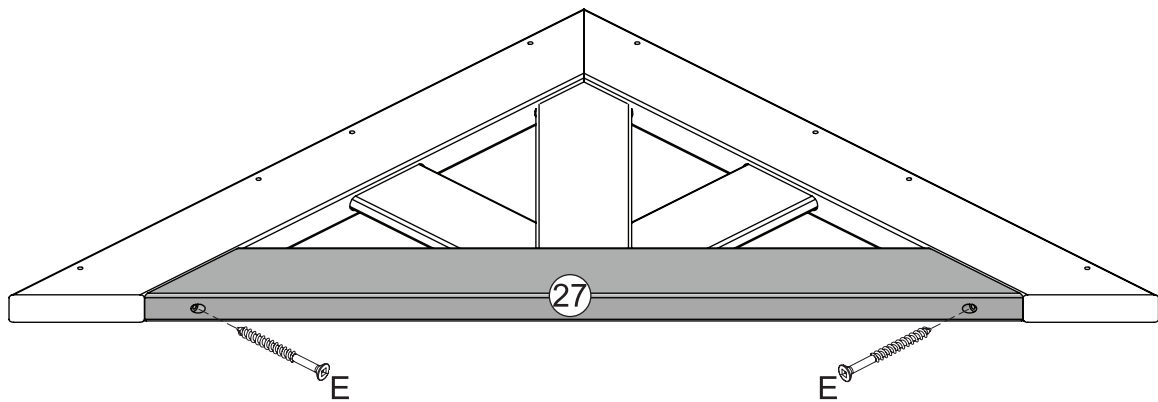

51



2 x E

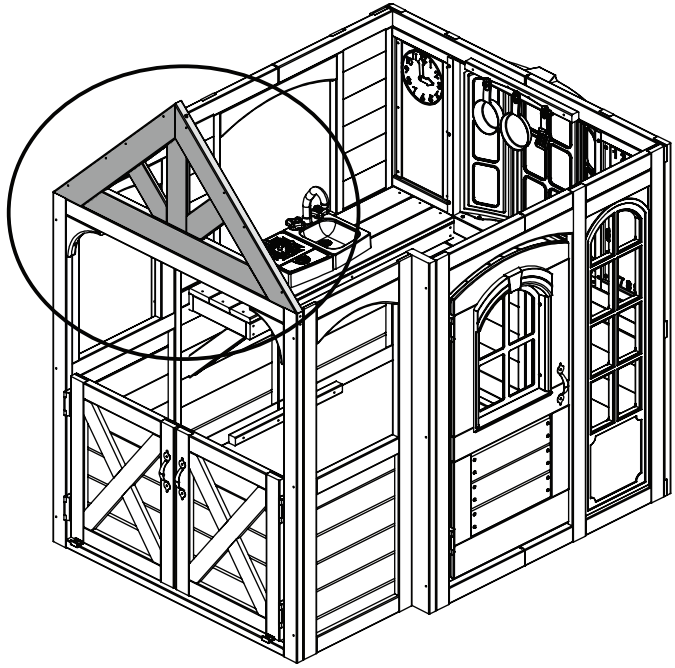
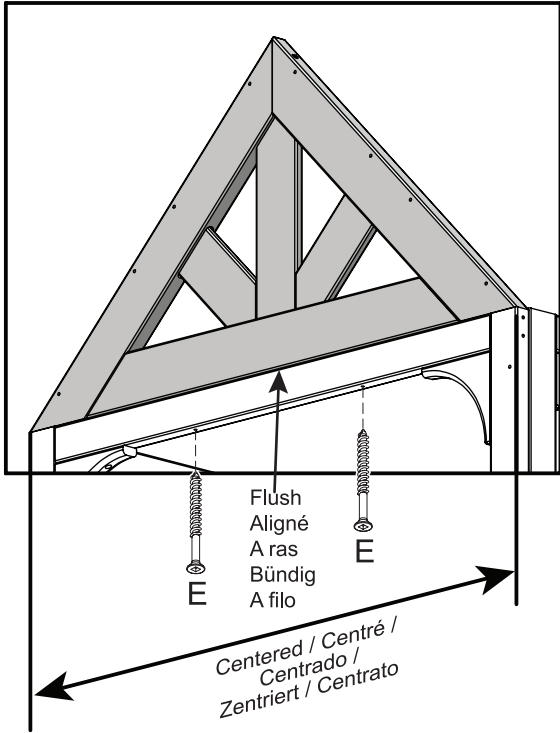

52

Complete this step twice
Répétez cette étape deux fois
Repita este paso dos veces
Wiederholen Sie diesen Schritt zweimal
Eseguire questo passaggio due volte



4 x 28

2 x E



Note the angled cut
Prenez note des entailles inclinées
Tenga en cuenta los cortes biselados
Die Winkelschnitte beachten
Prestare attenzione ai tagli inclinati

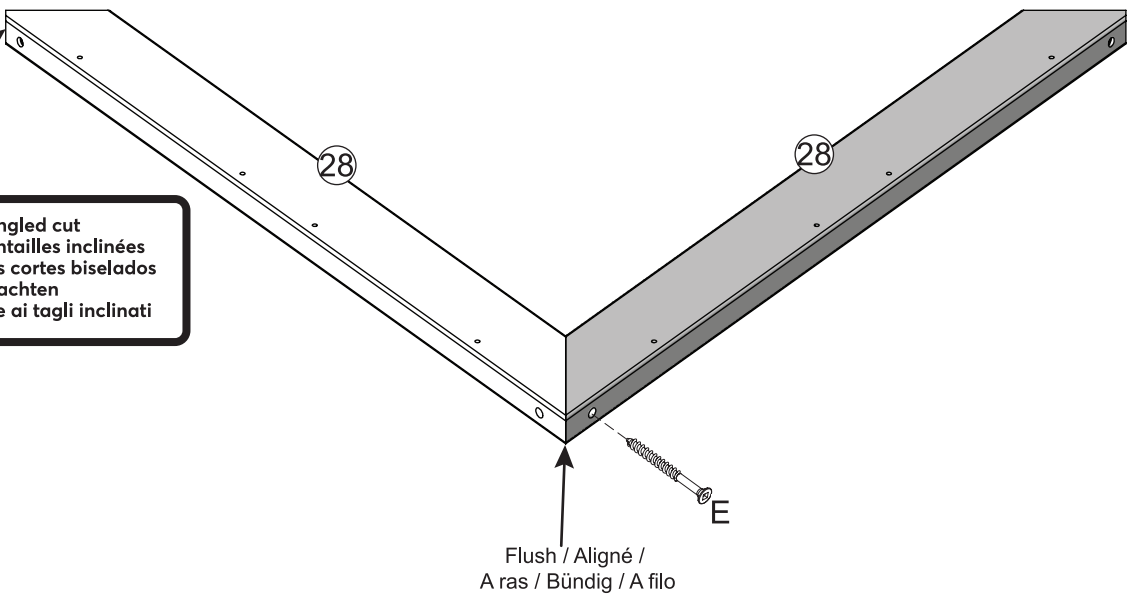

parts.kidkraft.com

customerservice@kidkraft.com
1.800.933.0771
972.385.0100

53

Complete this step twice
Répétez cette étape deux fois
Repita este paso dos veces
Wiederholen Sie diesen Schritt zweimal
Eseguire questo passaggio due volte



2 x 29

4 x E

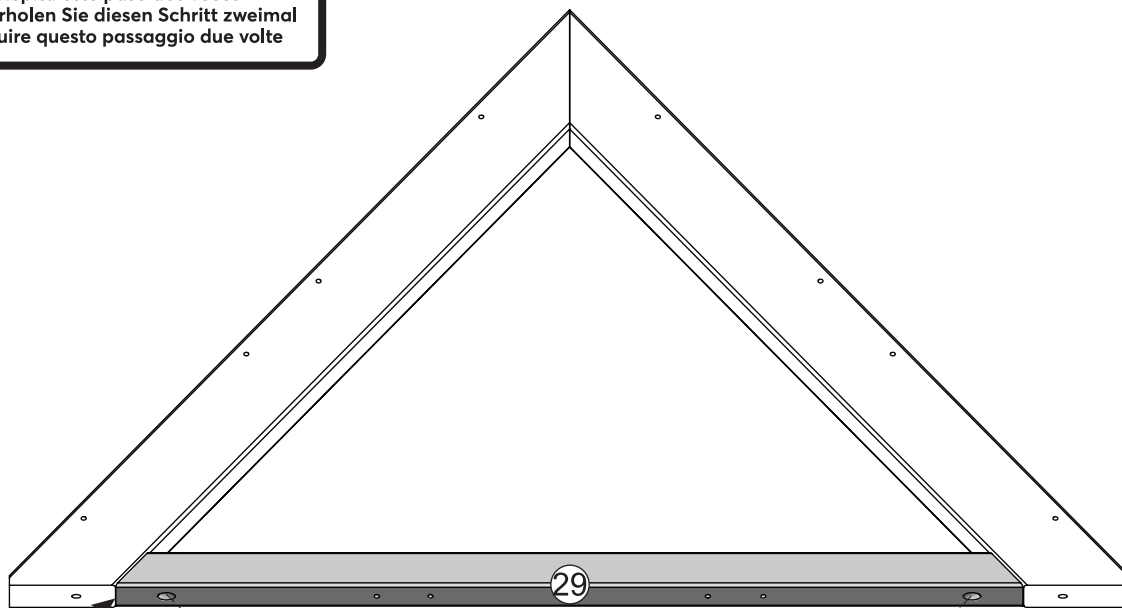

Flush
Aligné
A ras
Bündig
A filo

E

E

54

Complete this step twice
Répétez cette étape deux fois
Repita este paso dos veces
Wiederholen Sie diesen Schritt zweimal
Eseguire questo passaggio due volte



2 x 30A

4 x D

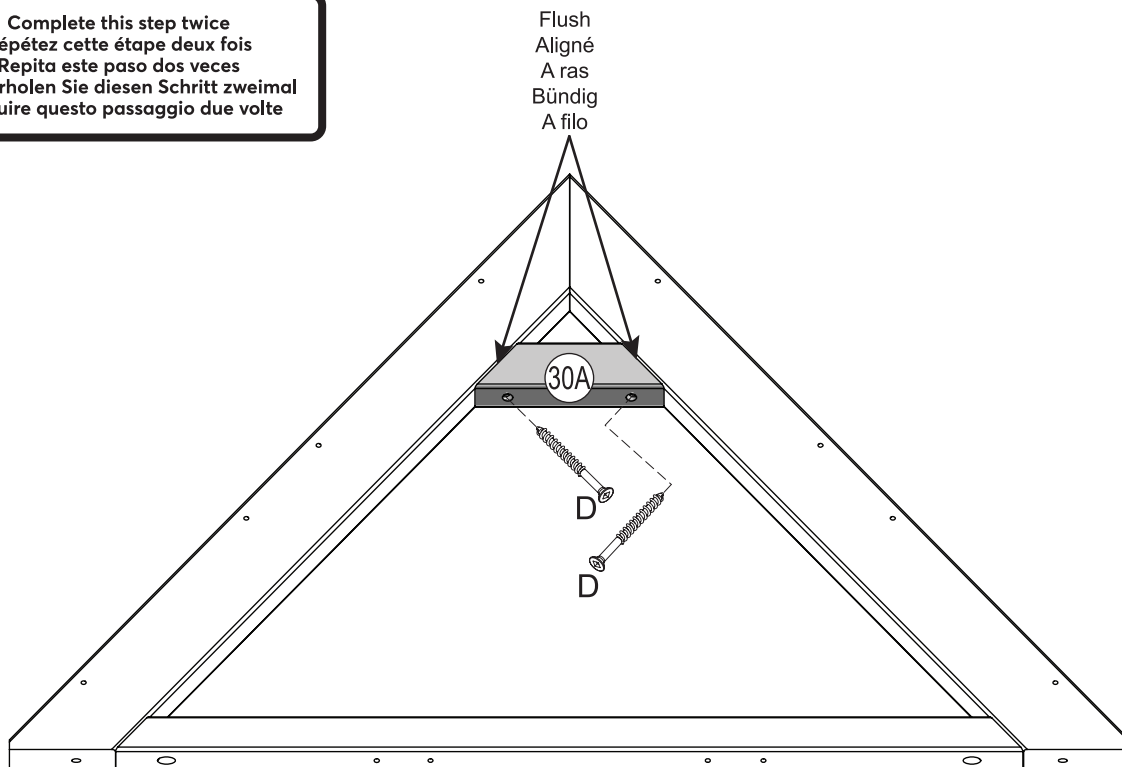

Flush
Aligné
A ras
Bündig
A filo

D

D



KidKraft
MADE FOR MAKE BELIEVE™

parts.kidkraft.com

customerservice@kidkraft.com
1.800.933.0771
972.385.0100

55

Complete this step twice
Répétez cette étape deux fois
Repita este paso dos veces
Wiederholen Sie diesen Schritt zweimal
Eseguire questo passaggio due volte



4 x 31

2 x 5943-WT

4 x D

4 x E

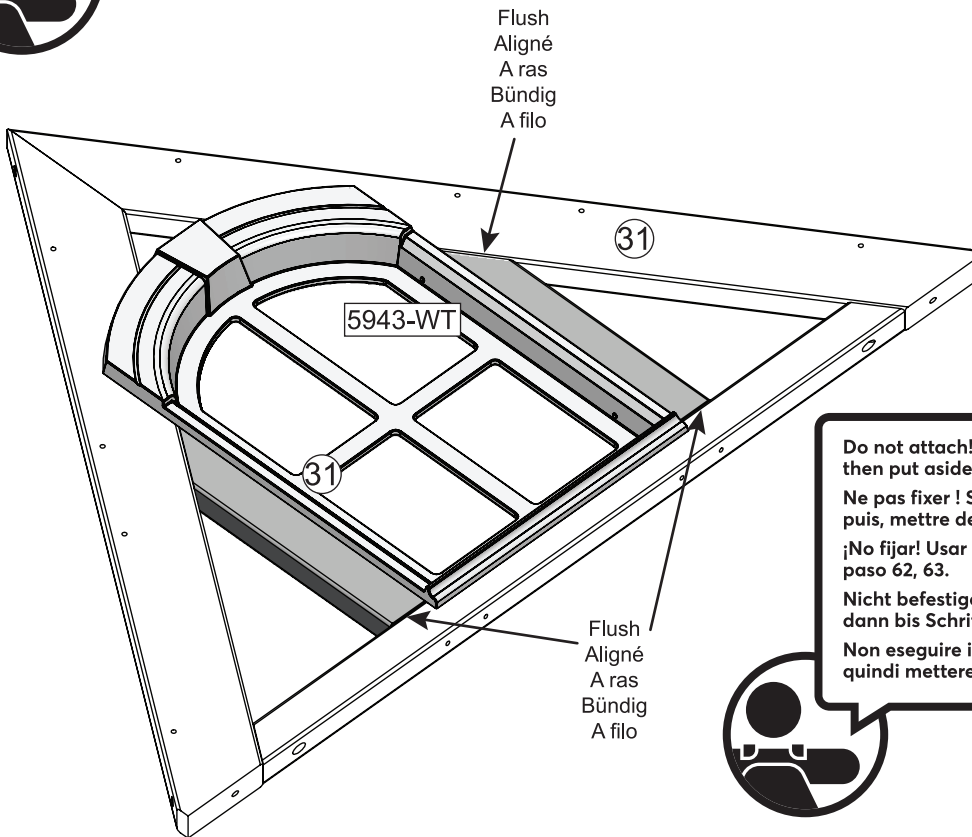

Do not attach! Use for alignment only, then put aside until Step 62, 63.
Ne pas fixer ! Sert uniquement pour l'alignement, puis, mettre de côté jusqu'à l'étape 62, 63.
¡No fijar! Usar solo para alinear y reservar hasta el paso 62, 63.
Nicht befestigen! Nur zur Ausrichtung verwenden, dann bis Schritt 62, 63 beiseite stellen.
Non eseguire il fissaggio! Utilizzare solo per allineare, quindi mettere da parte fino alla Fase 62, 63.

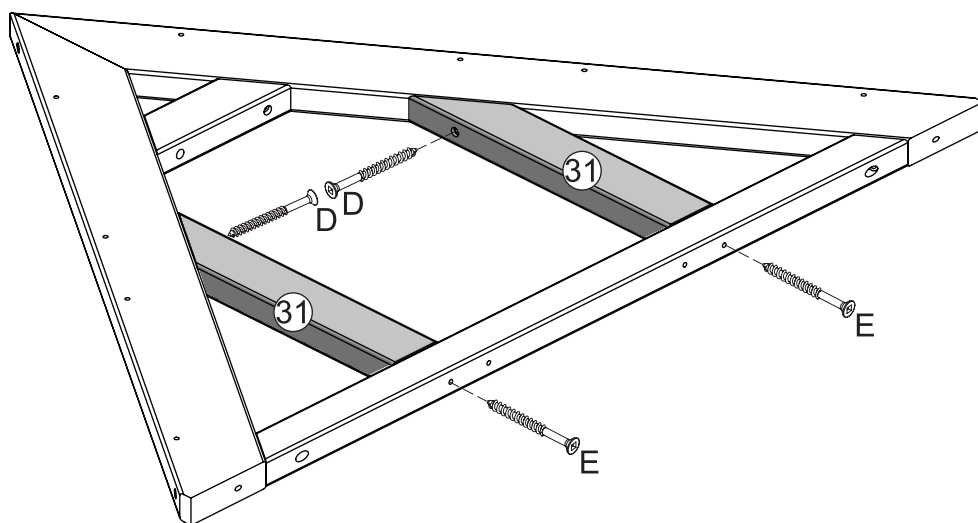
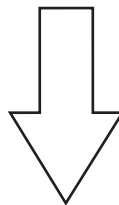

56

Complete this step twice
Répétez cette étape deux fois
Repita este paso dos veces
Wiederholen Sie diesen Schritt zweimal
Eseguire questo passaggio due volte



2 x 32

4 x B

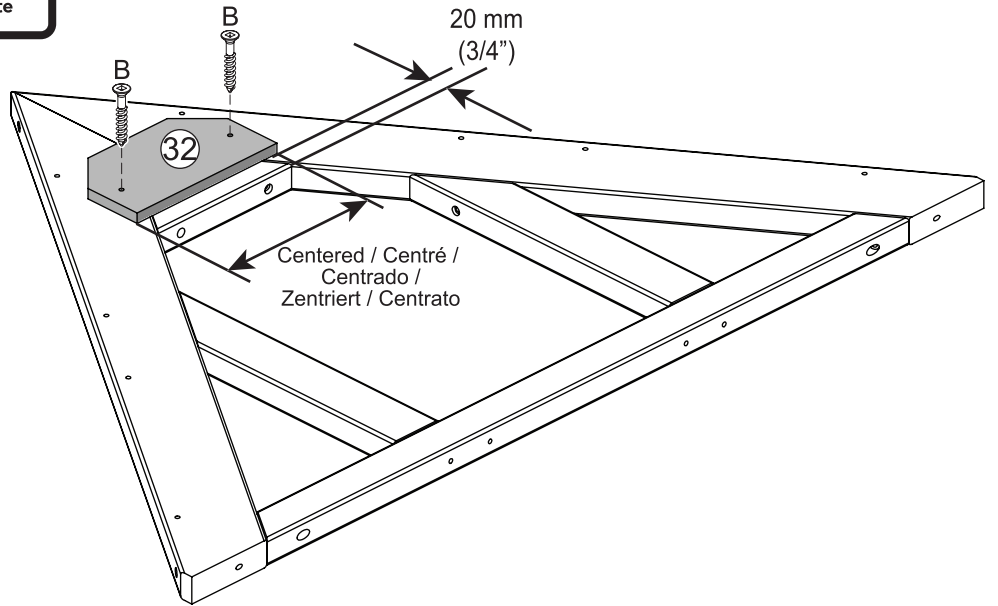

57



4 x 33

4 x 34

24 x B

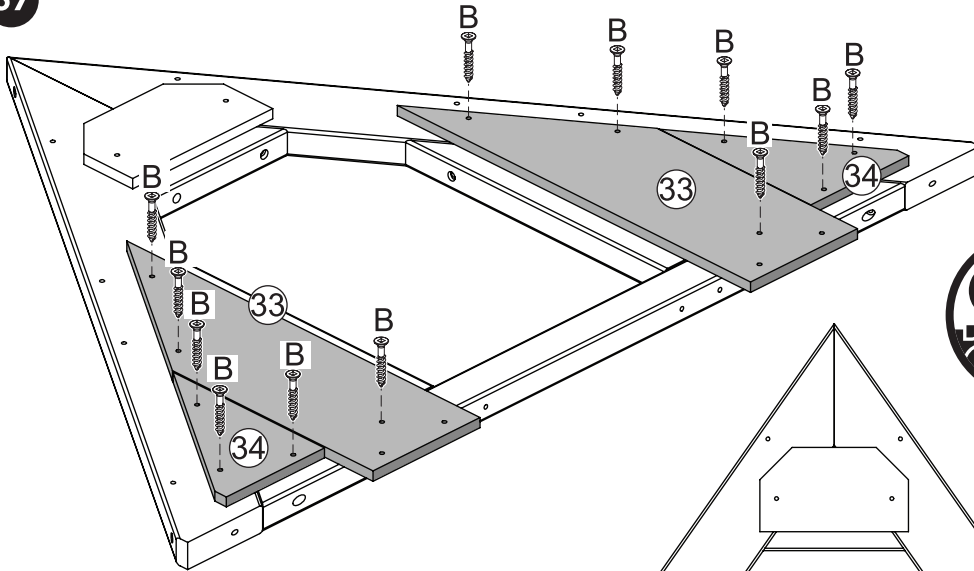

Complete this step twice
Répétez cette étape deux fois
Repita este paso dos veces
Wiederholen Sie diesen Schritt zweimal
Eseguire questo passaggio due volte

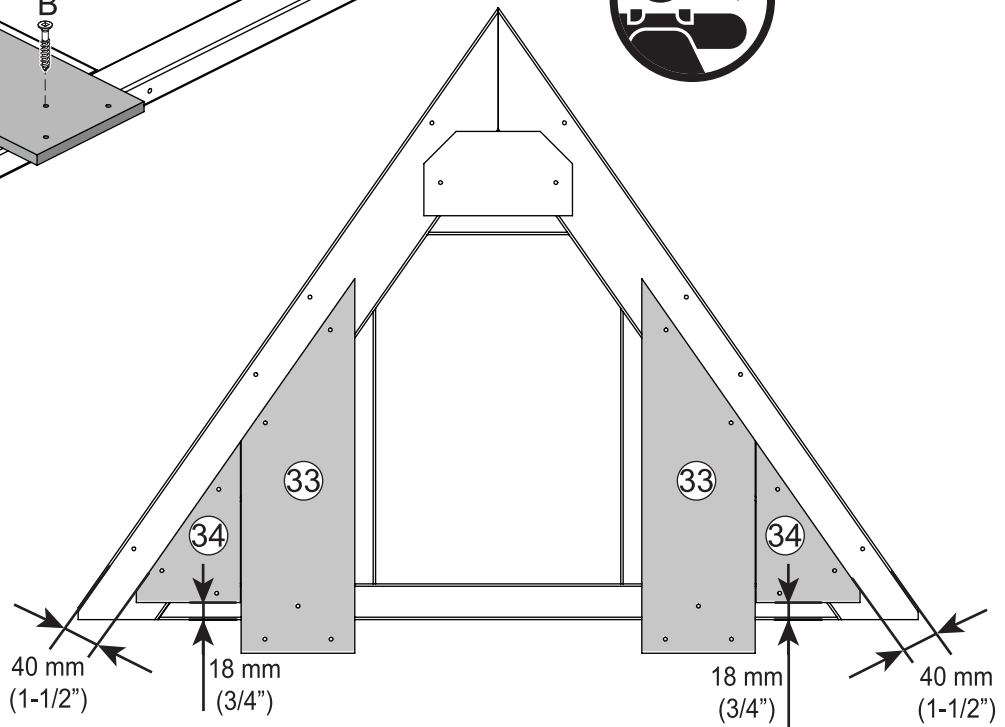

parts.kidkraft.com

customerservice@kidkraft.com
1.800.933.0771
972.385.0100

58



4 x E

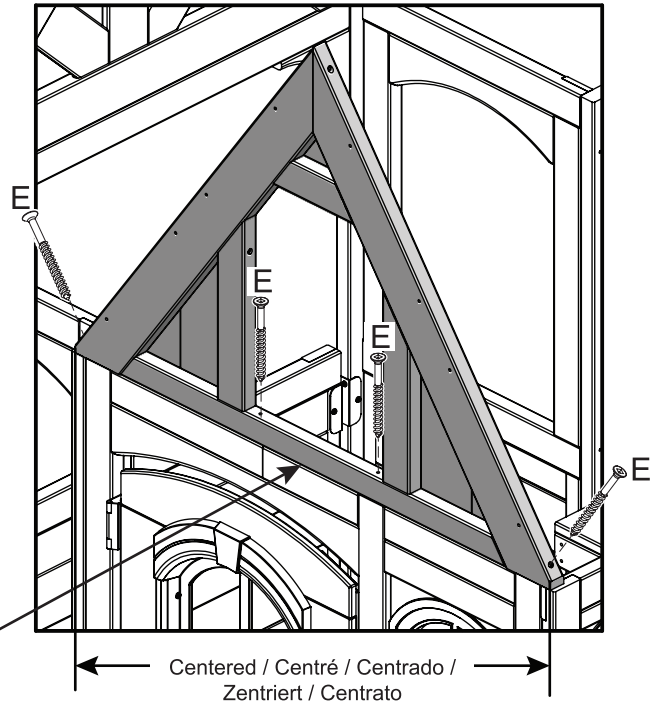
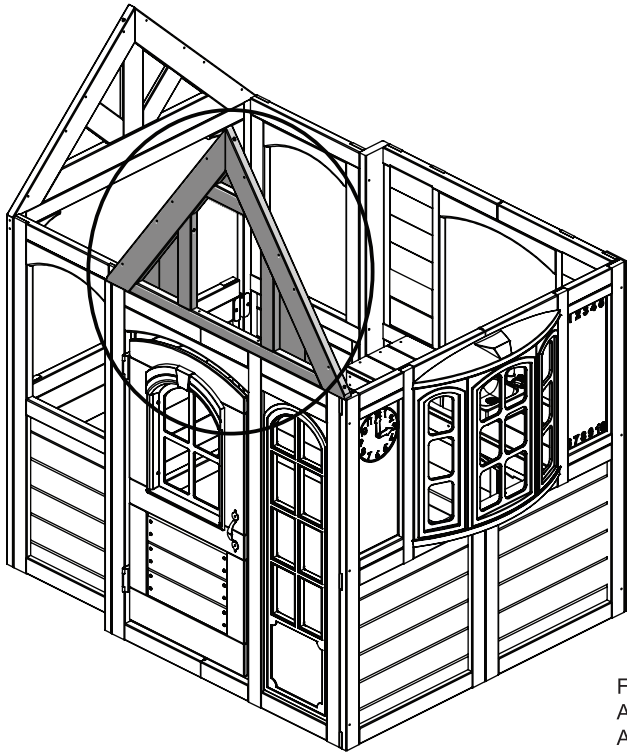

Flush
Aligné
A ras
Bündig
A filo

Centered / Centré / Centrado /
Zentriert / Centrato

59



4 x B

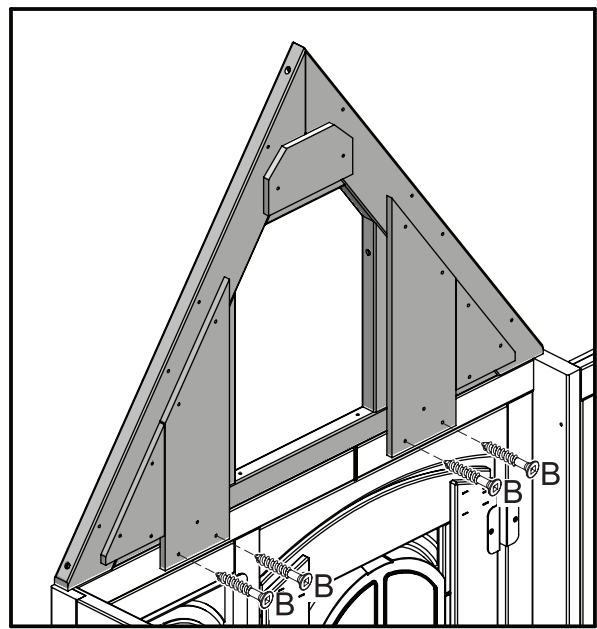
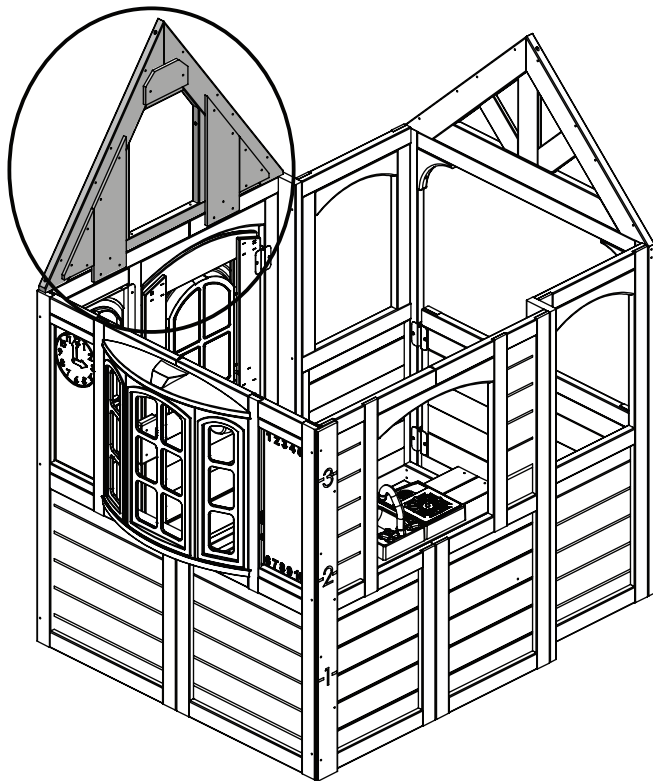

parts.kidkraft.com

customerservice@kidkraft.com
1.800.933.0771
972.385.0100

60

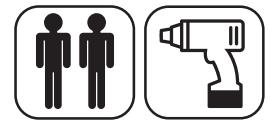

4 x E

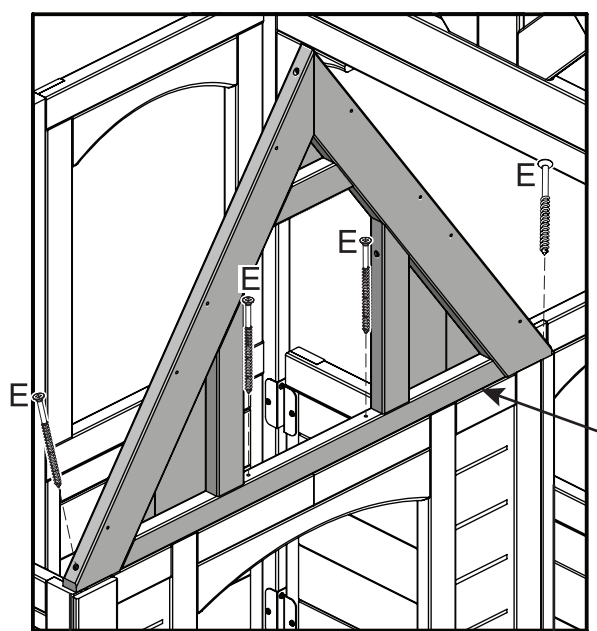
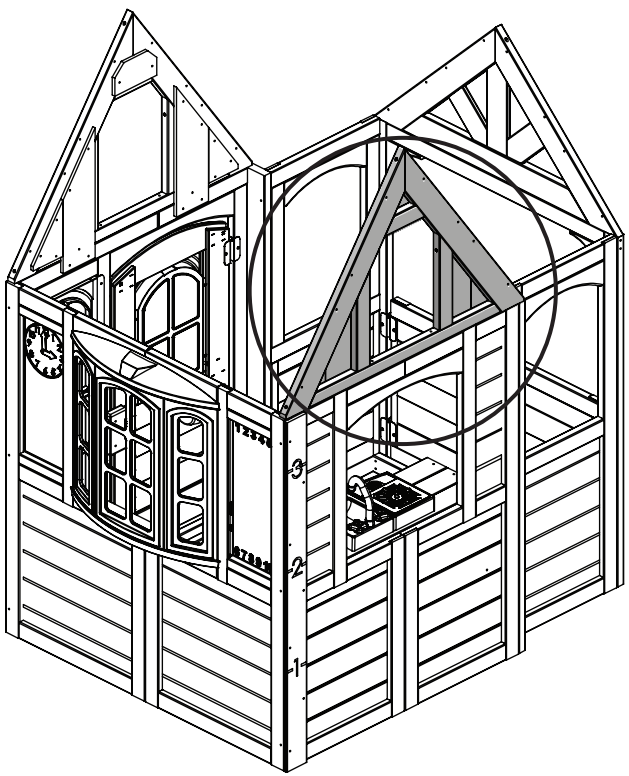

Flush
Aligné
A ras
Bündig
A filo

Centered / Centré / Centrado /
Zentriert / Centrato

61



4 x B

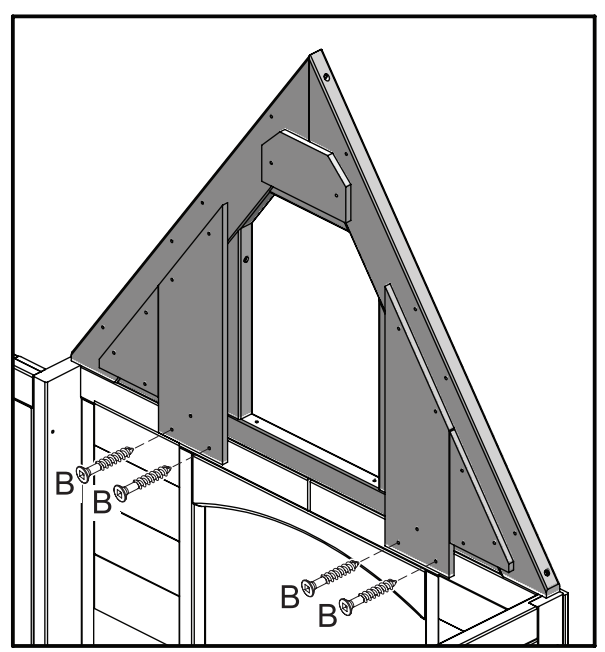
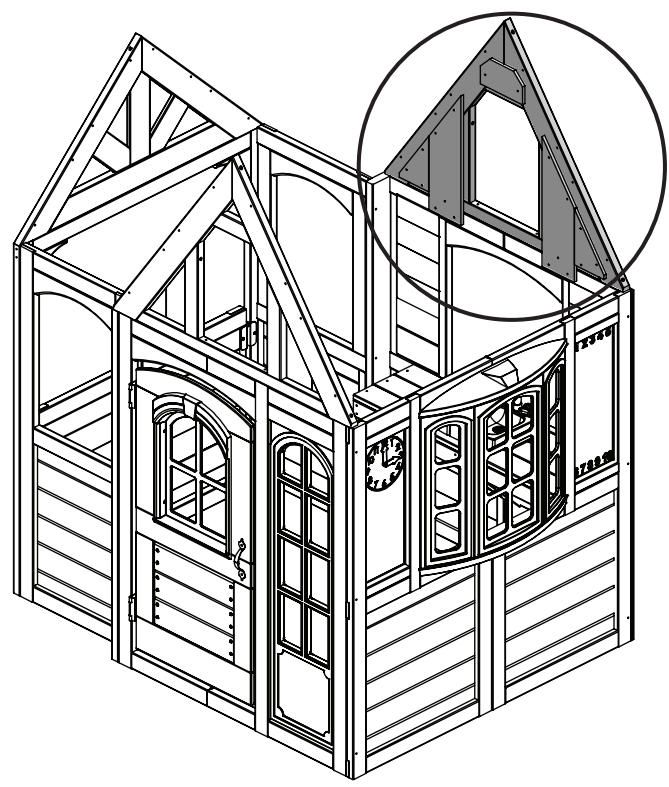

parts.kidkraft.com

customerservice@kidkraft.com
1.800.933.0771
972.385.0100

62

DO NOT over tighten the Screw.
NE serrez PAS TROP la vis.
NO aprietas demasiado el tornillo.
Ziehen Sie die Schraube NICHT zu fest an.
NON serrare eccessivamente la vite.



4 x A

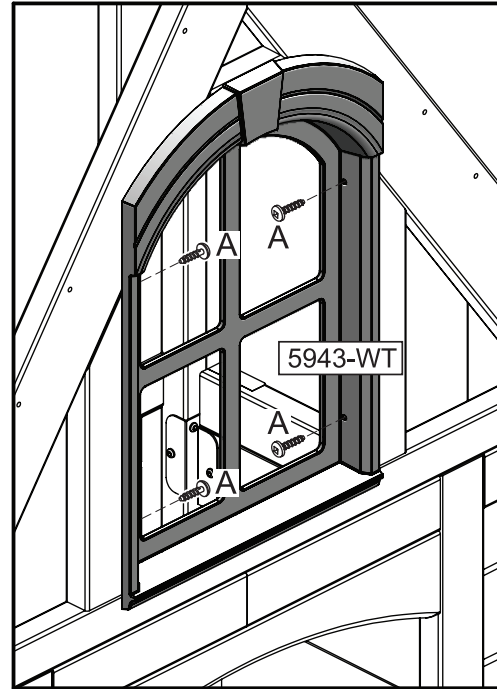
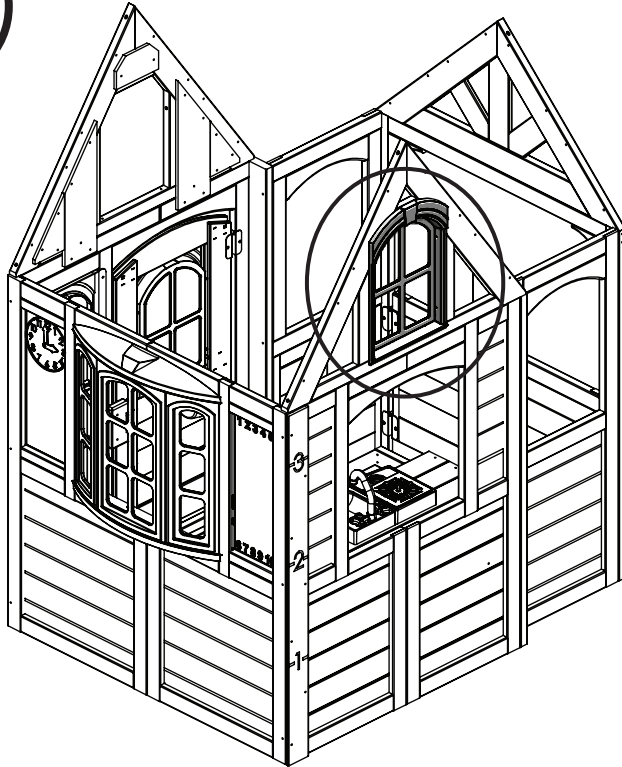

63

DO NOT over tighten the Screw.
NE serrez PAS TROP la vis.
NO aprietas demasiado el tornillo.
Ziehen Sie die Schraube NICHT zu fest an.
NON serrare eccessivamente la vite.



4 x A

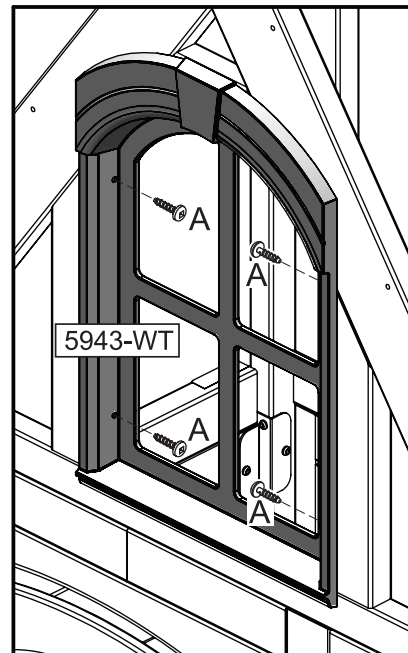
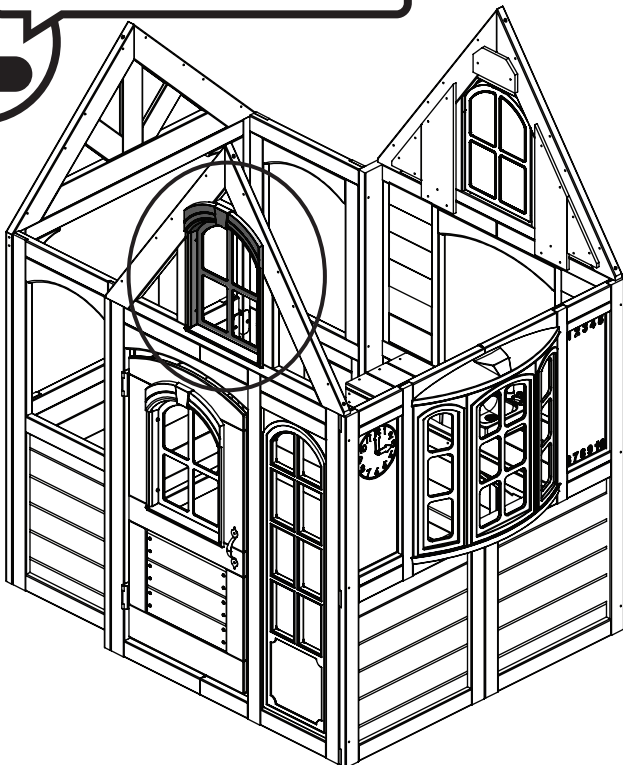



1 x 35

4 x C

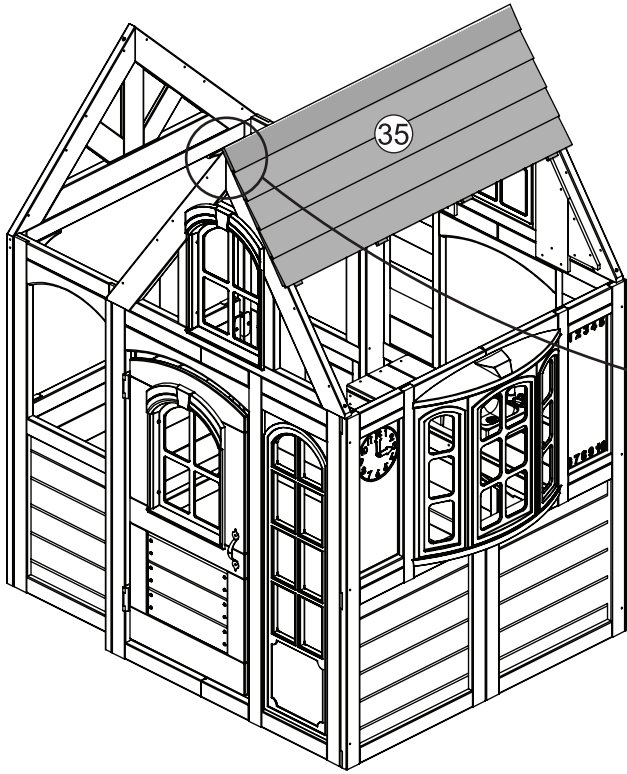

Flush
Aligné
A ras
Bündig
A filo

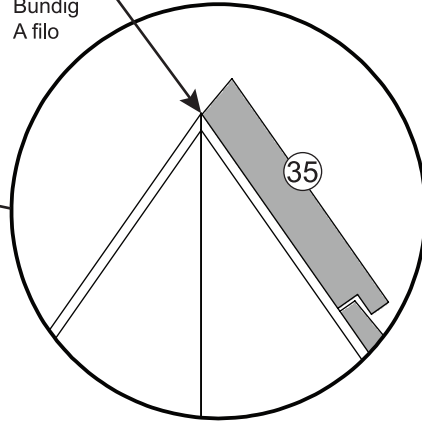

Side View
Vue latérale
Vista lateral
Seitenansicht
Vista laterale

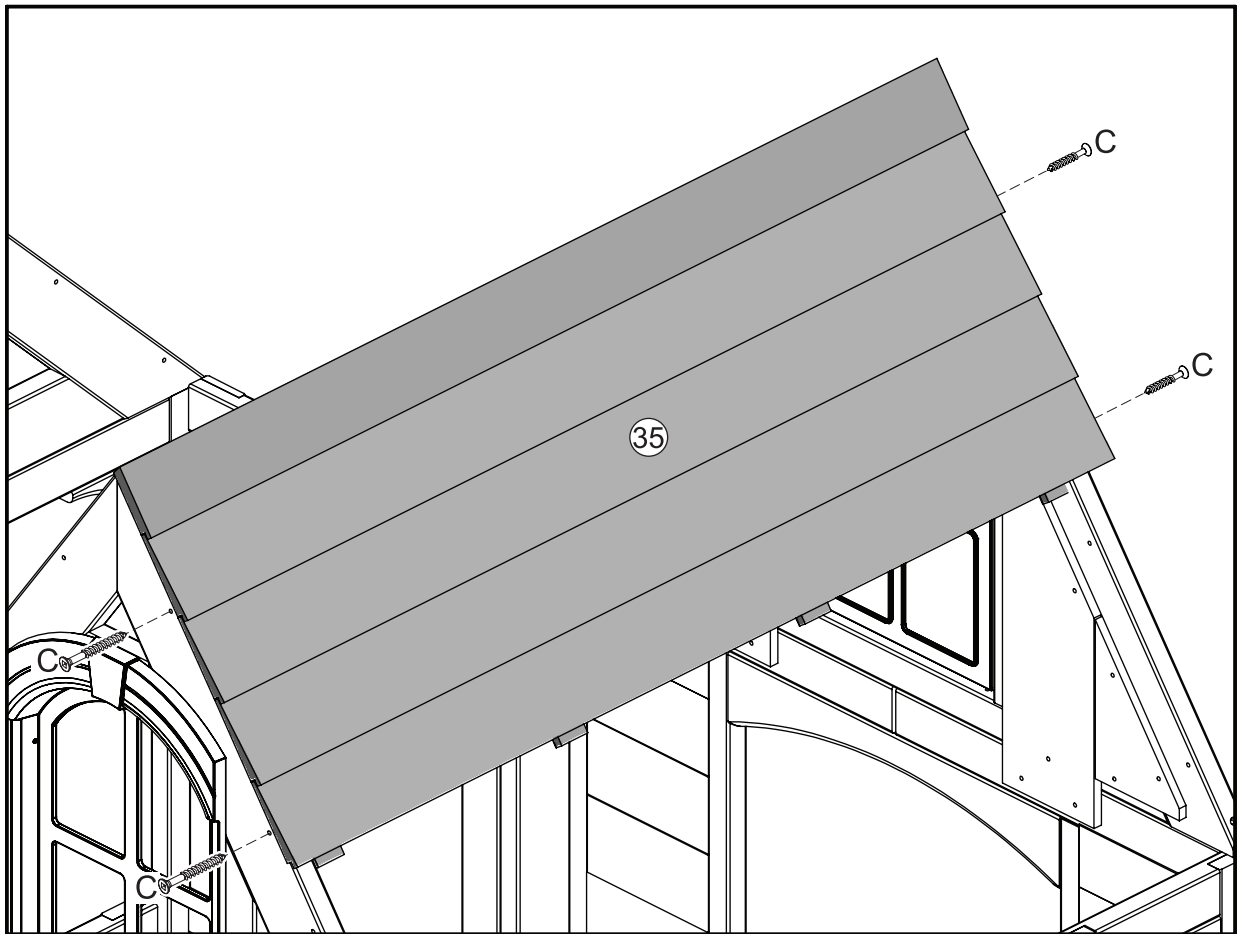



1 x 36

4 x C

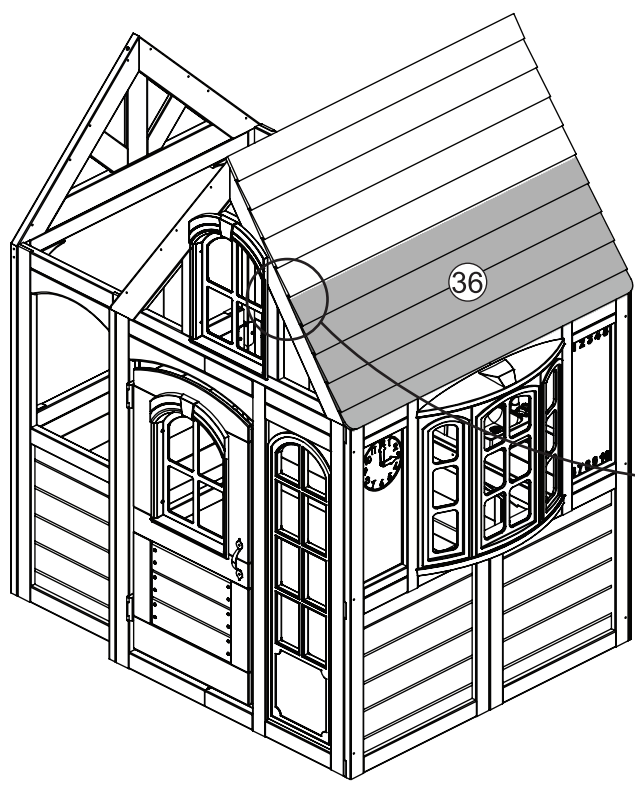

Tight
Serré
Ajustado
Eng anliegend
Serrato

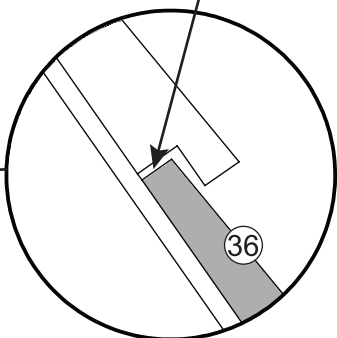

Side View
Vue latérale
Vista lateral
Seitenansicht
Vista laterale

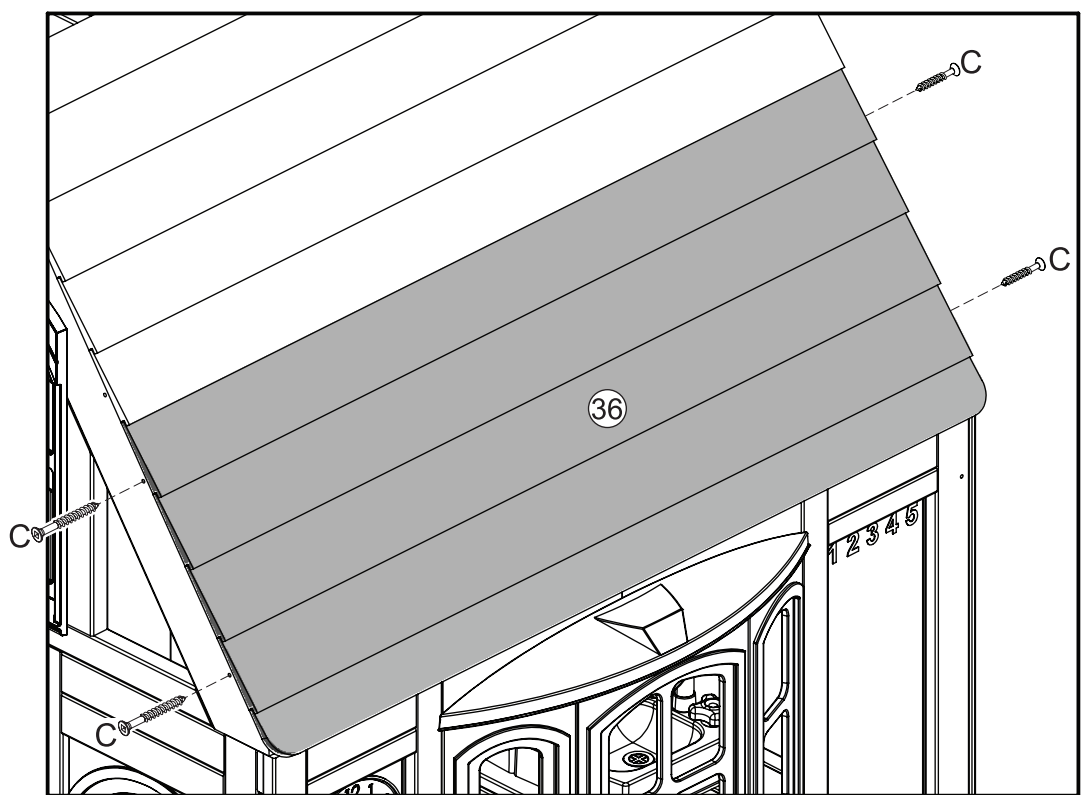



1 x 37

4 x C

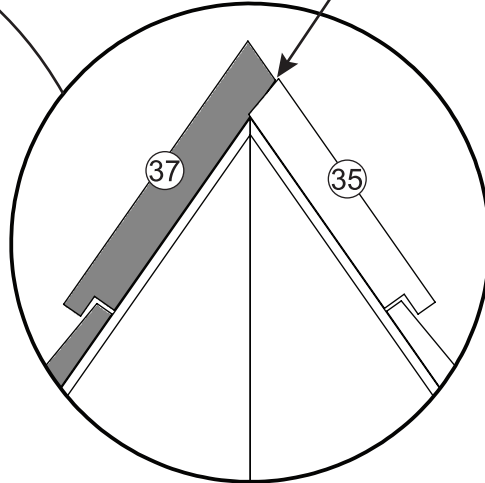
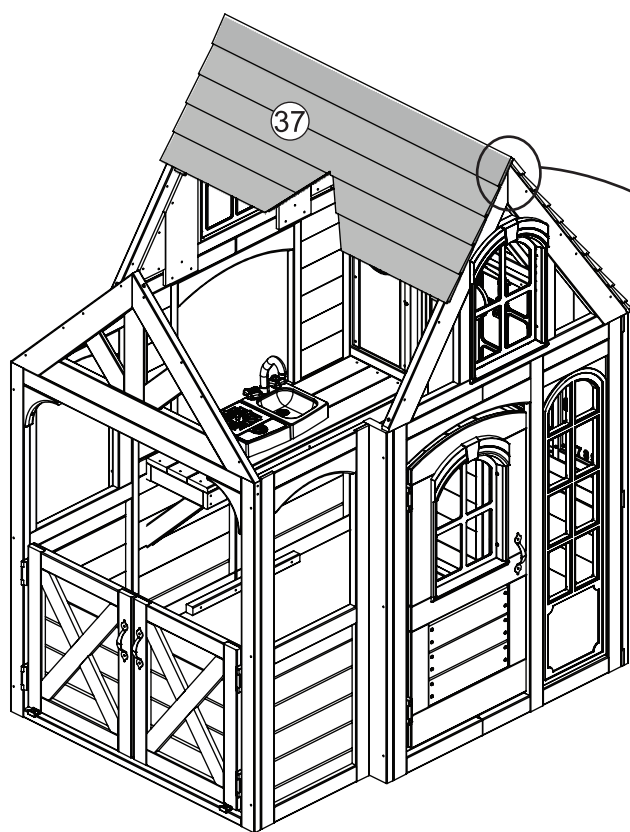

Flush
Aligné
A ras
Bündig
A filo

Side View
Vue latérale
Vista lateral
Seitenansicht
Vista laterale

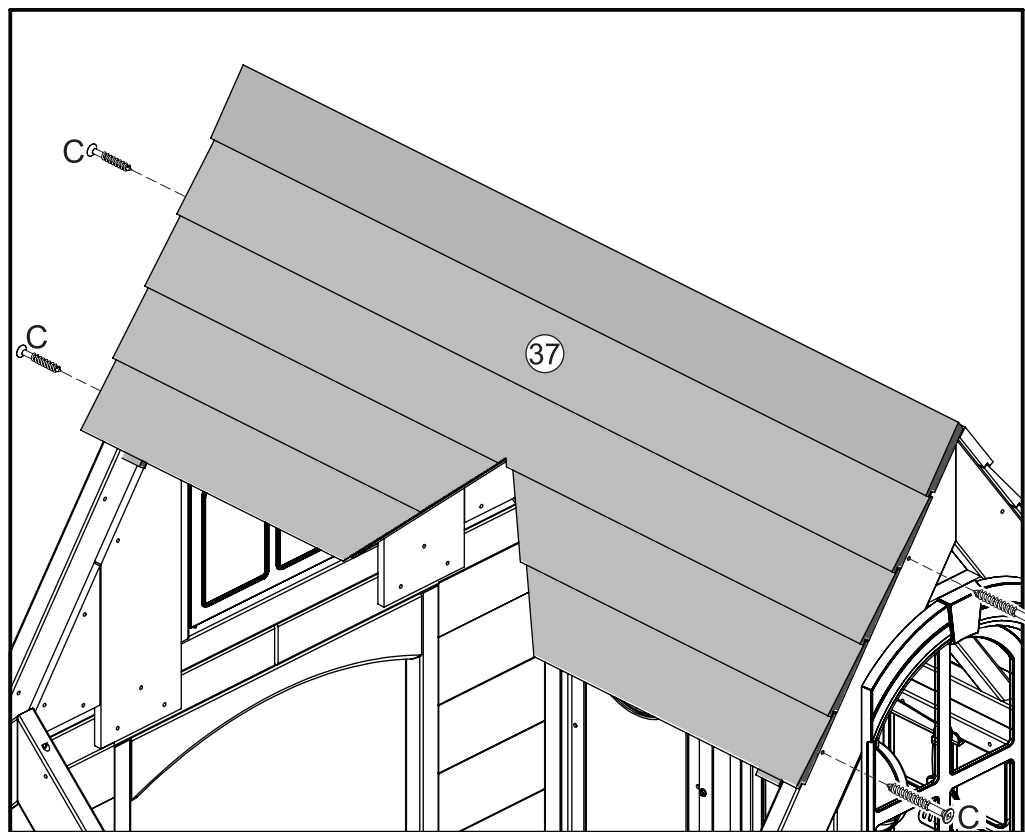



1 x 38

1 x 39

4 x C

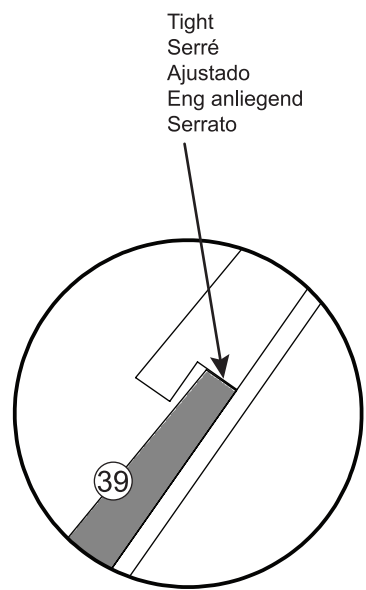
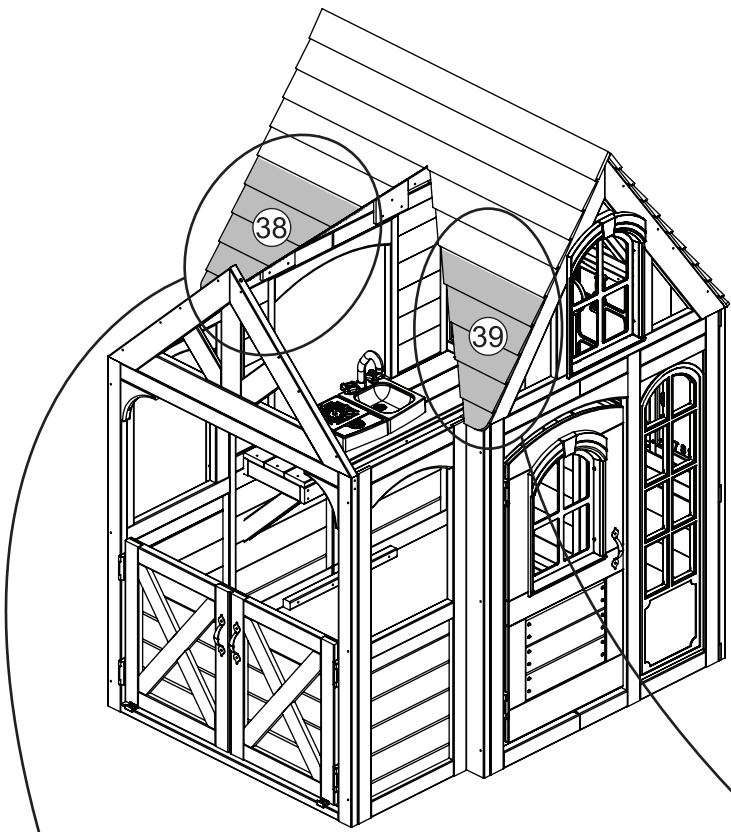

Tight
Serré
Ajustado
Eng anliegend
Serrato

Side View
Vue latérale
Vista lateral
Seitenansicht
Vista laterale

Rotated View / Vue tournée /
Vista girada / Gedrehte Ansicht /
Nuovo orientamento

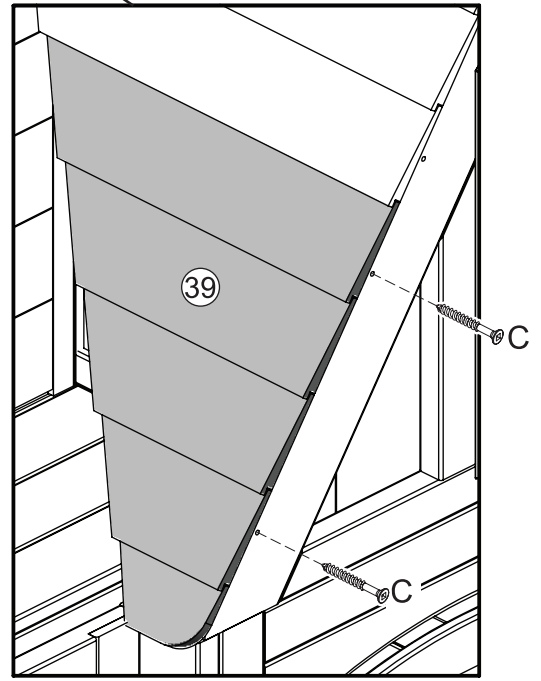
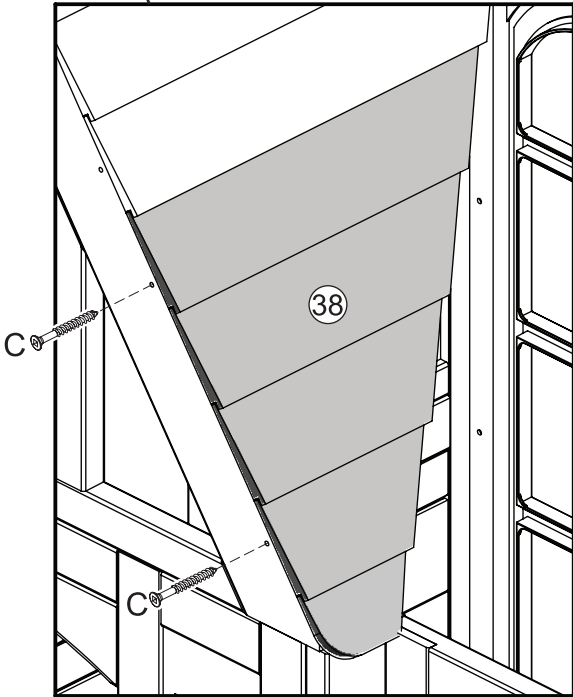



1 x 40

2 x C

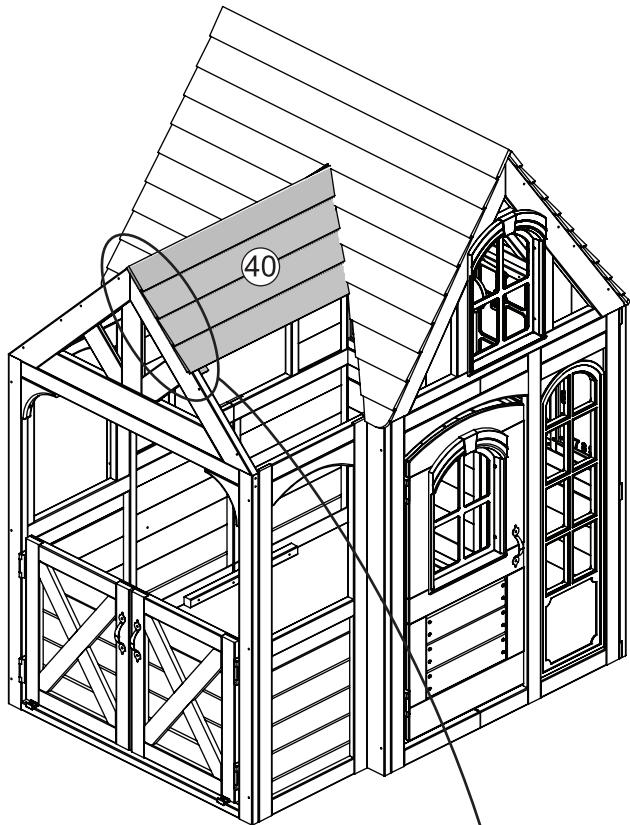

Flush
Aligné
A ras
Bündig
A filo

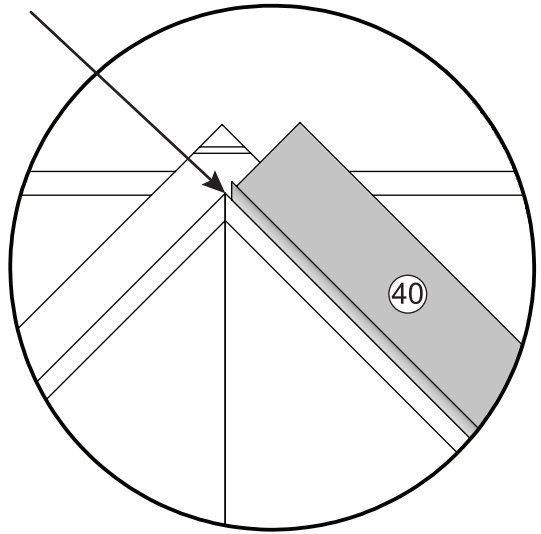

Side View
Vue latérale
Vista lateral
Seitenansicht
Vista laterale

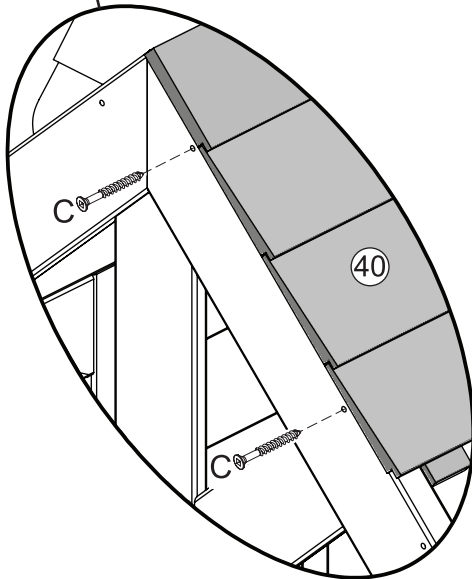



1 x 41
2 x C

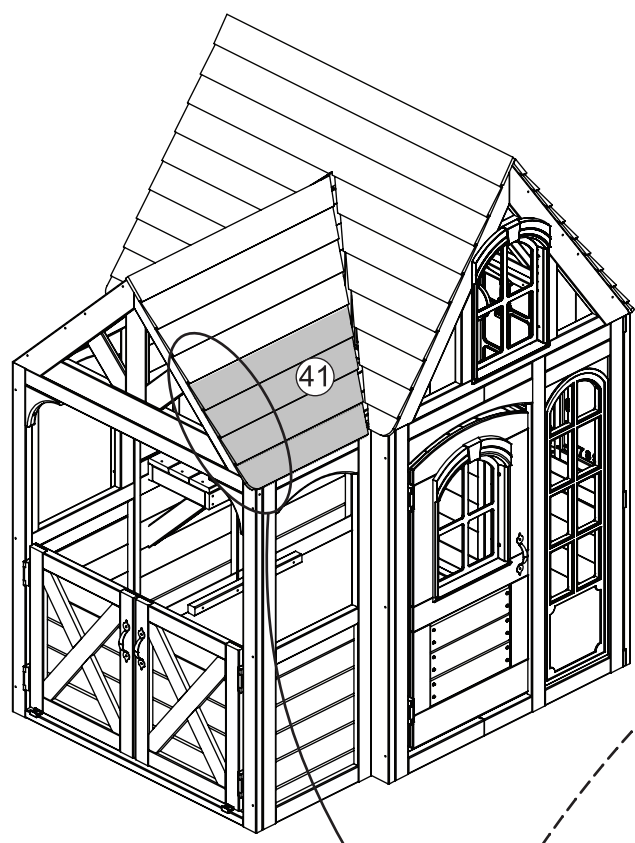

Tight
Serré
Ajustado
Eng anliegend
Serrato

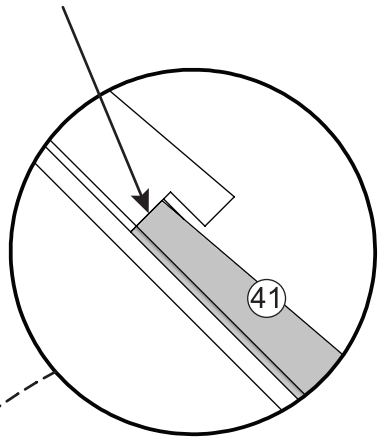

Side View
Vue latérale
Vista lateral
Seitenansicht
Vista laterale

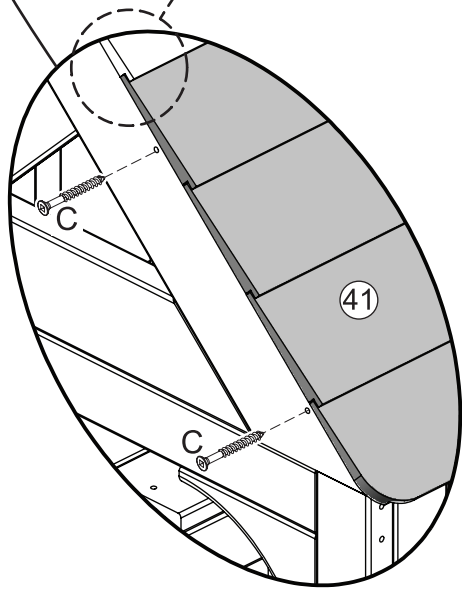



1 x 42

2 x C

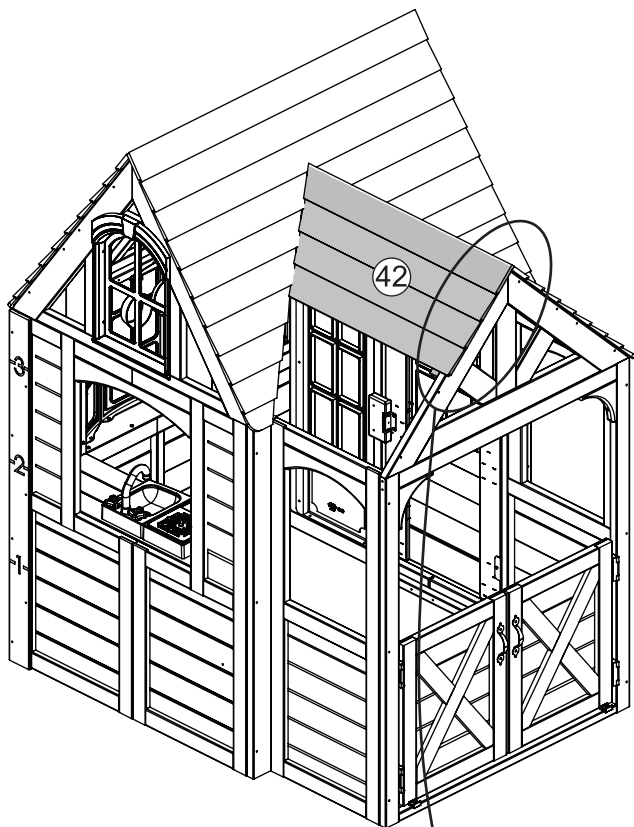

Flush
Aligné
A ras
Bündig
A filo

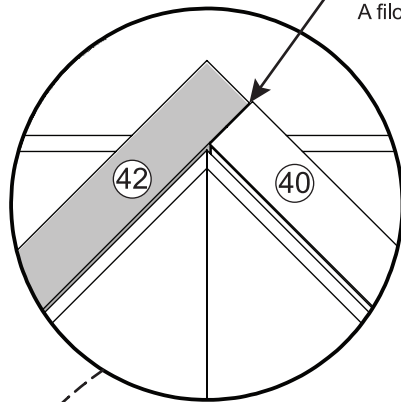

Side View
Vue latérale
Vista lateral
Seitenansicht
Vista laterale

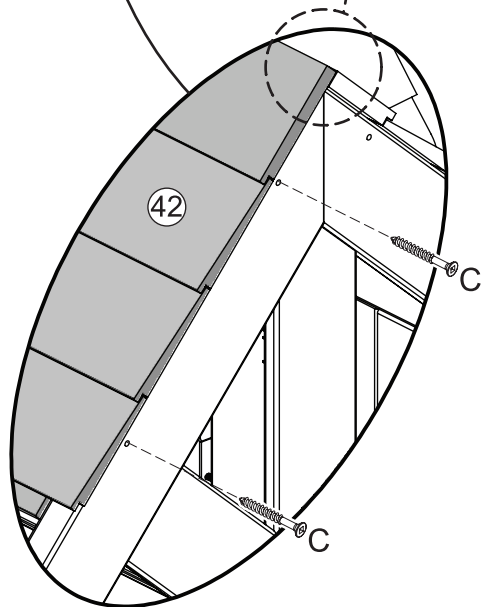



1 x 43

2 x C

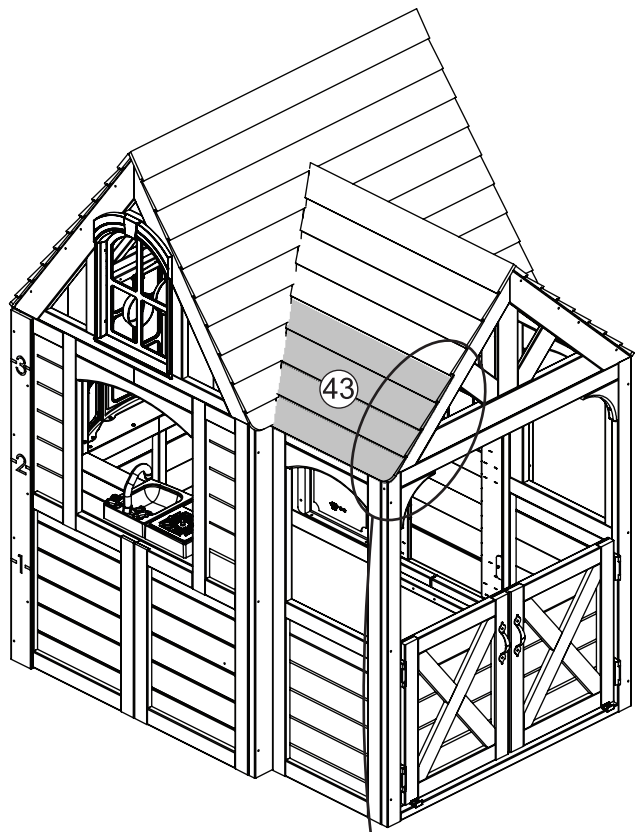

Tight
Serré
Ajustado
Eng anliegend
Serrato

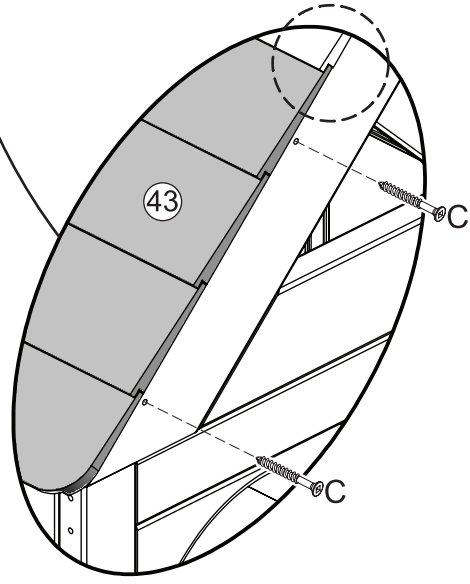
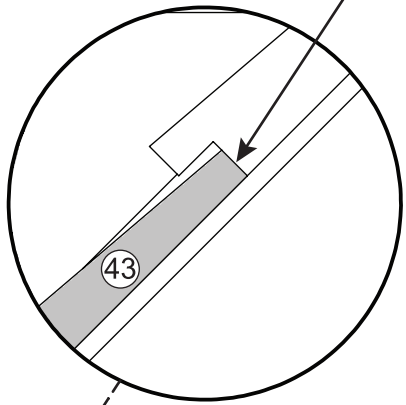



2 x 44
24 x A

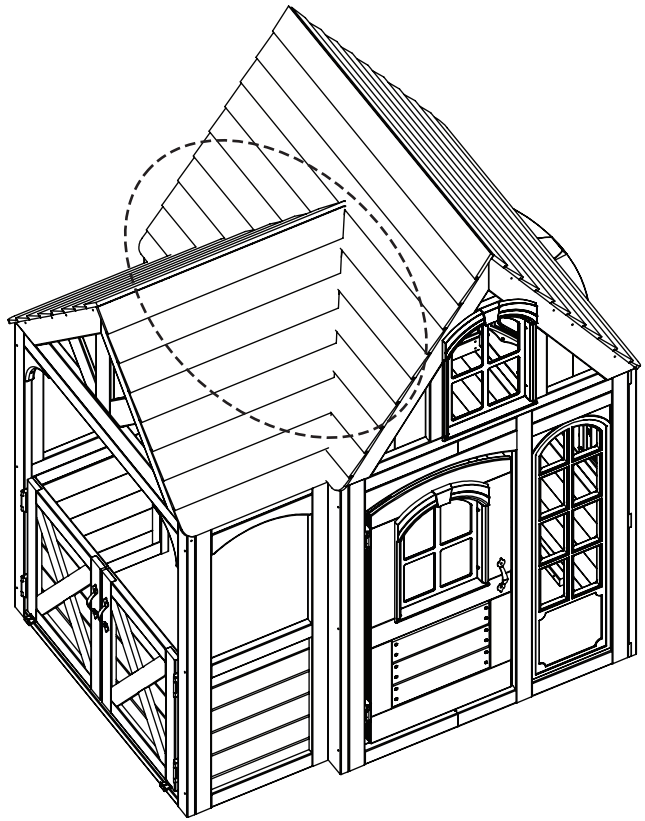

Inside and Underneath View
Vue intérieure et de dessous
Vista interior e inferior
Innen- und Unteransicht
Vista dall'interno e dal basso

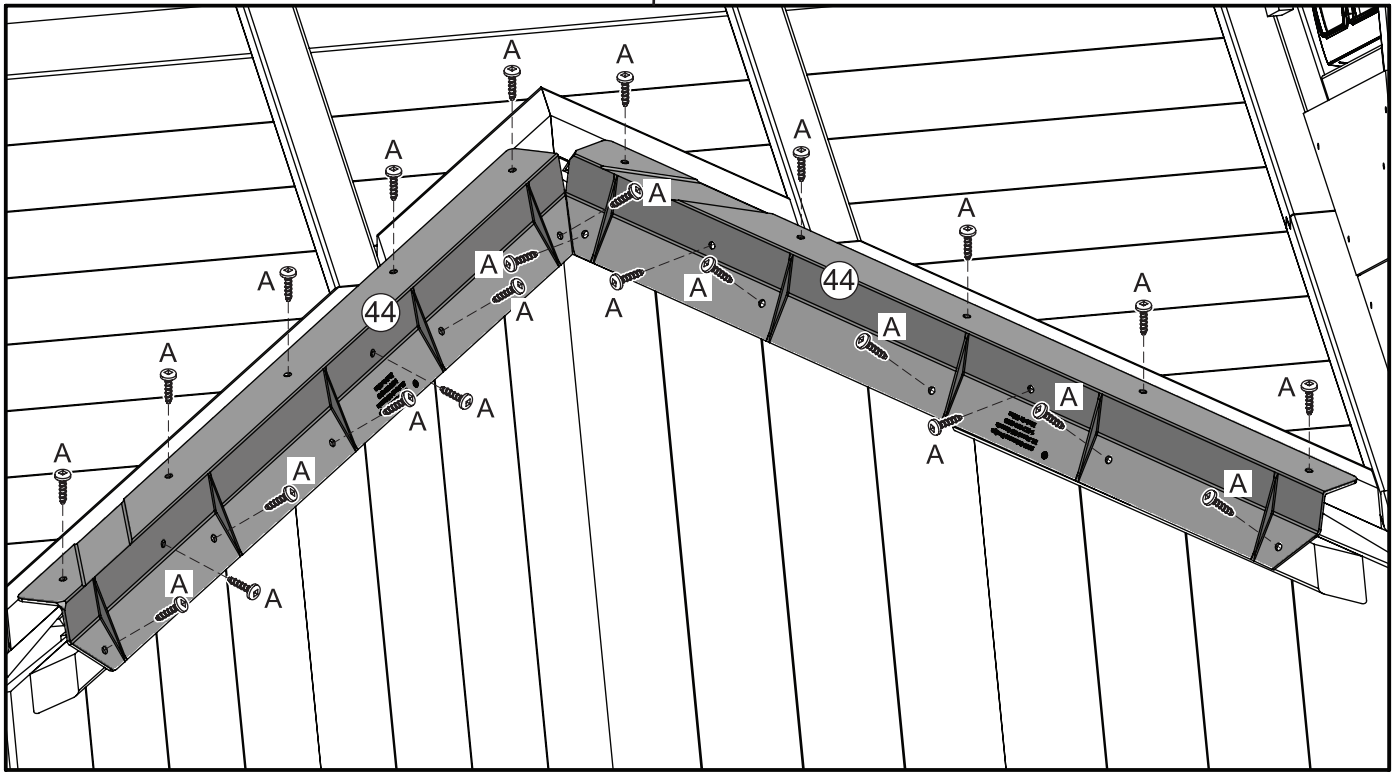
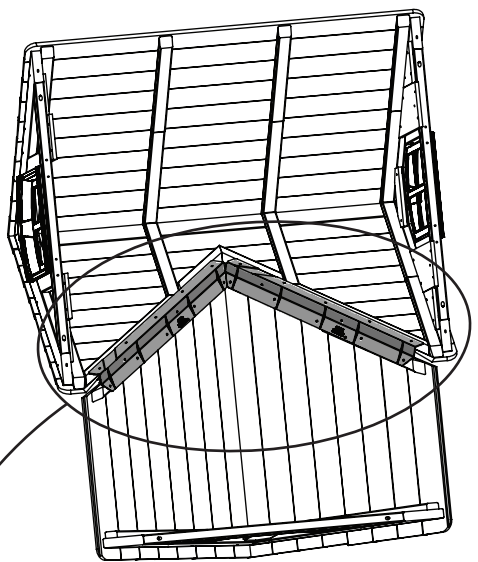



2 x 30B

4 x D

Inside and Underneath View
Vue intérieure et de dessous
Vista interior e inferior
Innen- und Untersicht
Vista dall'interno e dal basso

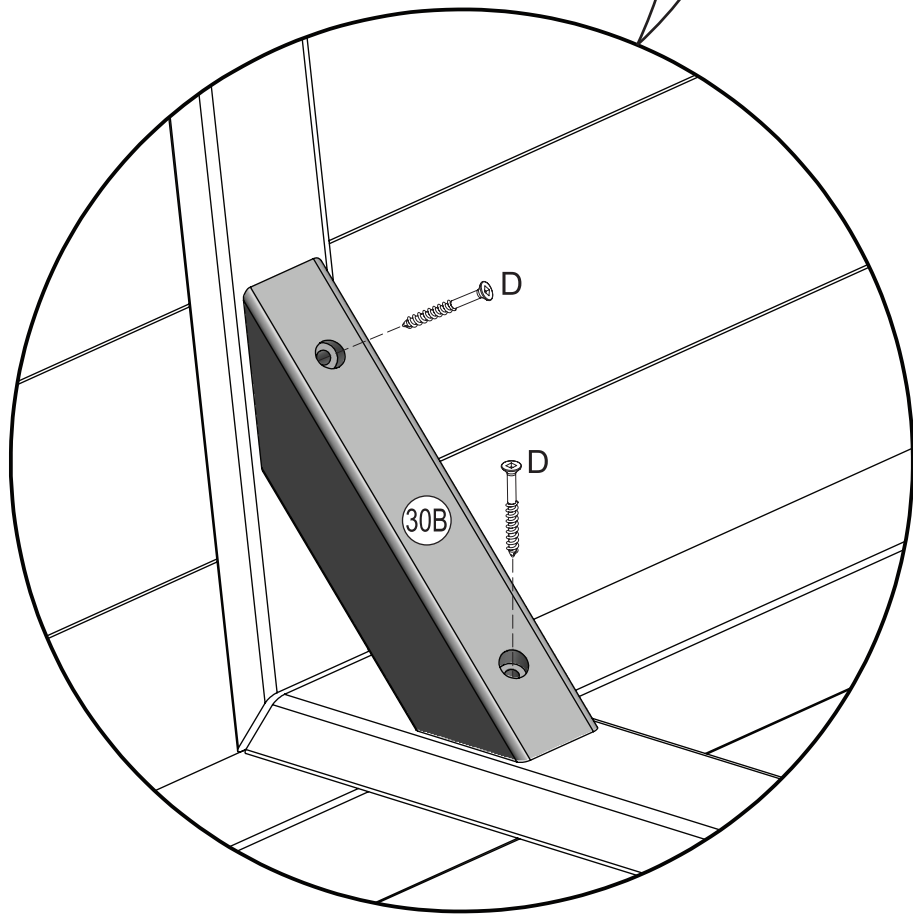
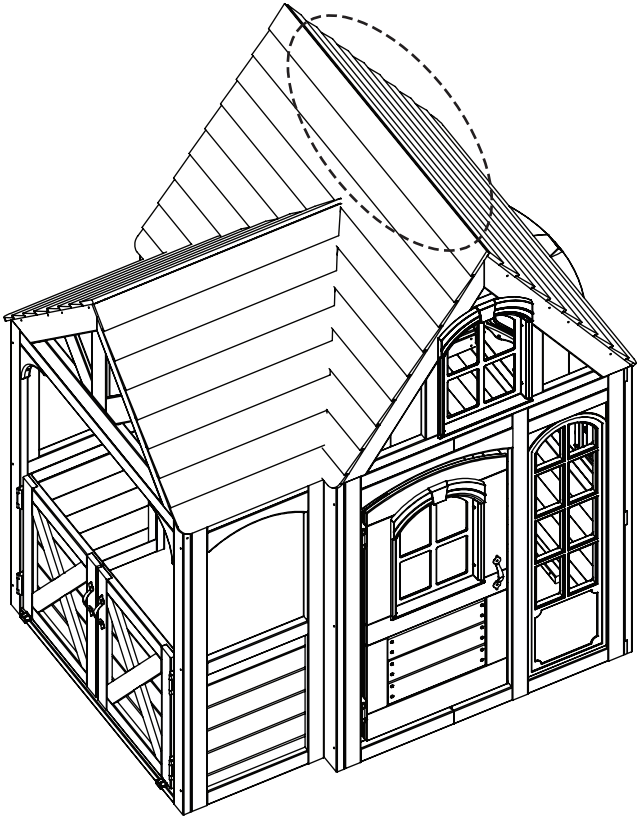



1 x 4448-MNRV

2 x A

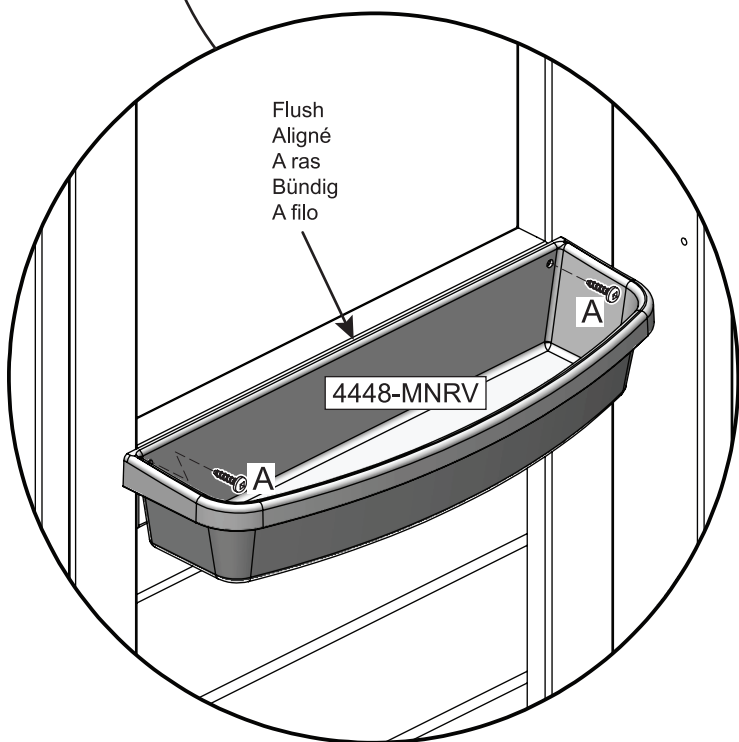
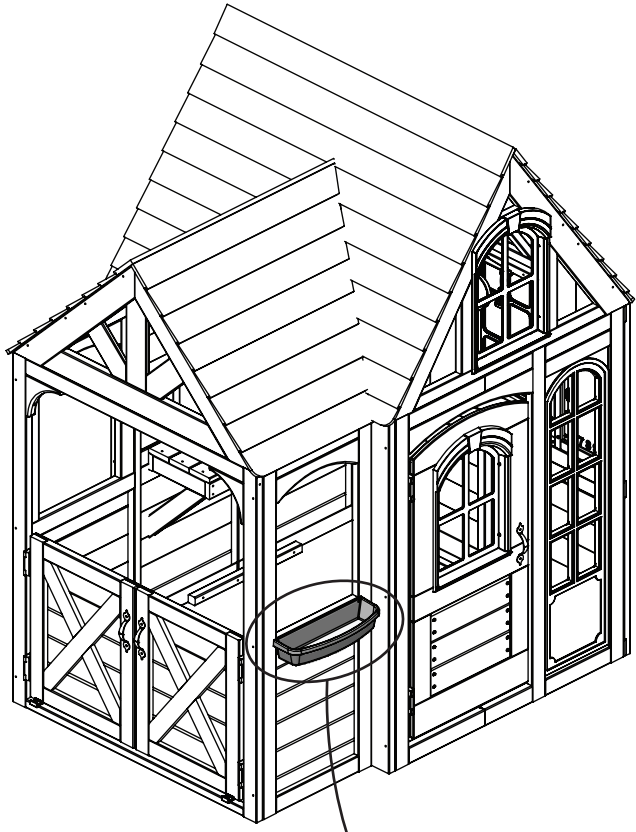

Flush
Aligné
A ras
Bündig
A filo

4448-MNRV

A