

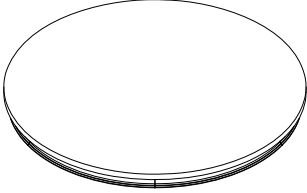

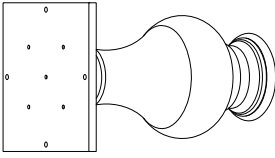

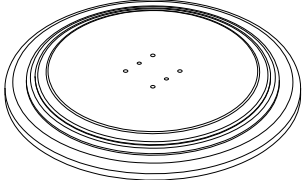

Assembly Instructions

SKU # 51030756

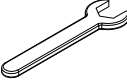
SKU # 51031095

PARTS LIST

A	TABLE TOP X 1							<p>Before beginning</p> <p>1) Carefully unpack and position the item on a clean, non-marring surface to assemble.</p> <p>2) Read this Assembly Instructions from beginning to end before starting to assemble.</p> <p>3) Take an inventory of the required parts to ensure all are available.</p> <p>4) To prevent accidental choking hazards, keep all packing materials away from small children.</p> <p>5) Only tighten hardware until ALL hardware are fully engaged on their locations. Overtighten bolts will damage the bolt threads.</p> <p>6) Use only factory provided hardware to assemble. Unapproved hardware can damage product or jeopardize the structural integrity of the product.</p> <p>7) The use of power tool to assemble is not recommended due to high risk of over-torque, which can damage the product.</p>
B	PEDESTAL X 1							
C	BASE X 1							
Z	HARDWARE	<p>Z1</p>  <p>4mm x1</p>	<p>Z2</p>  <p>8x85mm x4</p>	<p>Z3</p>  <p>13 mm x2</p>	<p>Z4</p>  <p>8x55 mm x4</p>	<p>Z5</p>  <p>8 mm x4</p>	<p>Z6</p>  <p>8mm x8</p>	<p>Z7</p>  <p>8mm x12</p>

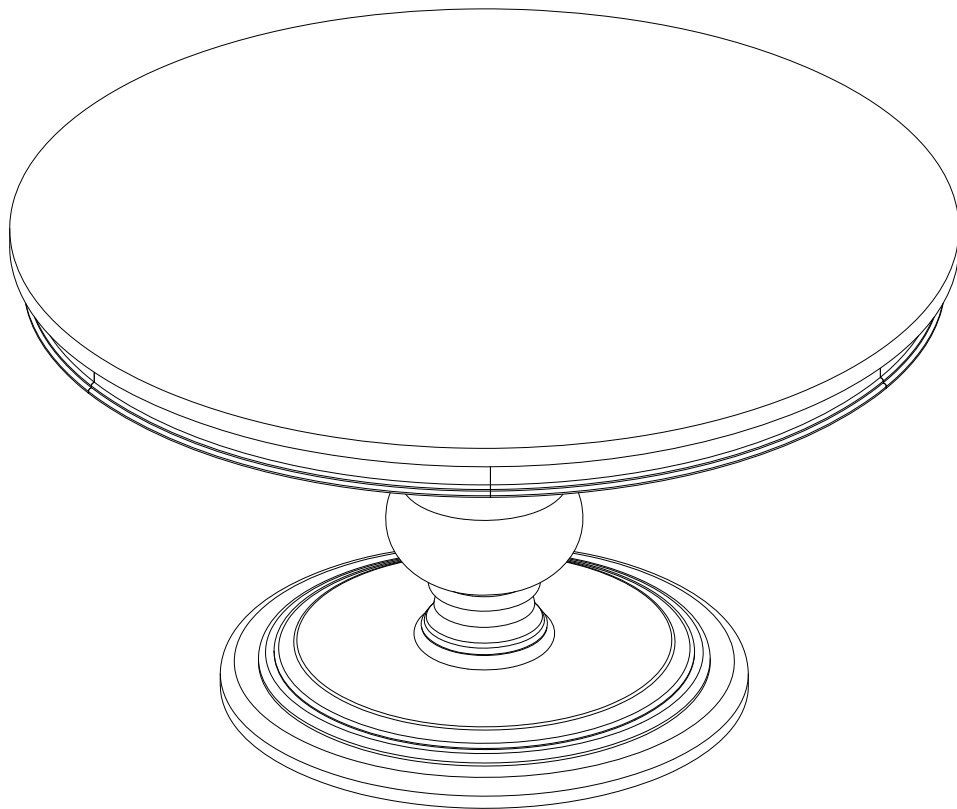

ASSEMBLY REQUIRES
TWO PEOPLE



15 MINUTE
ASSEMBLY TIME



KEEP INSTRUCTIONS
FOR FUTURE USE



Assembly Instructions

SKU # 51030756

SKU # 51031095

1

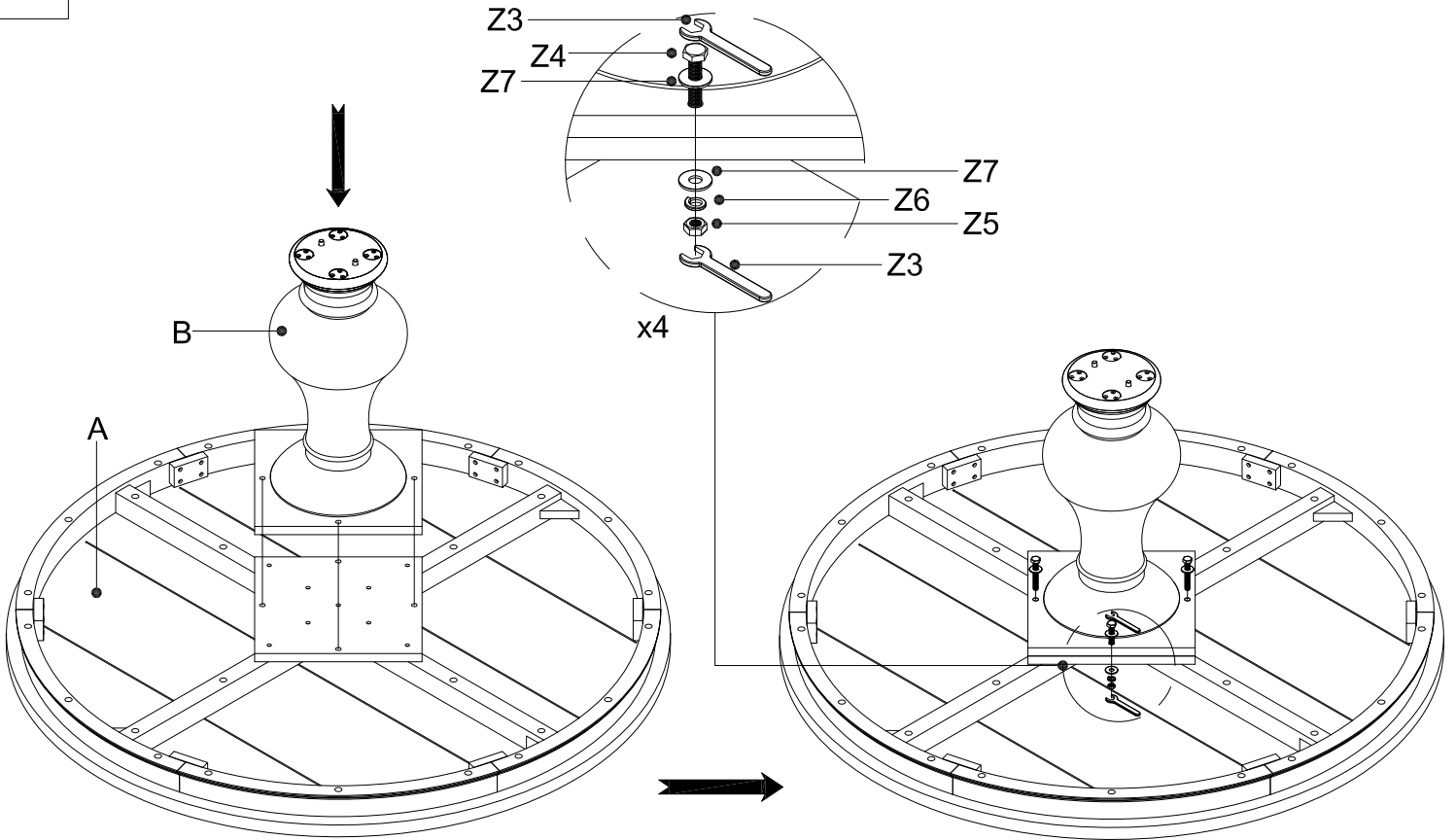

2

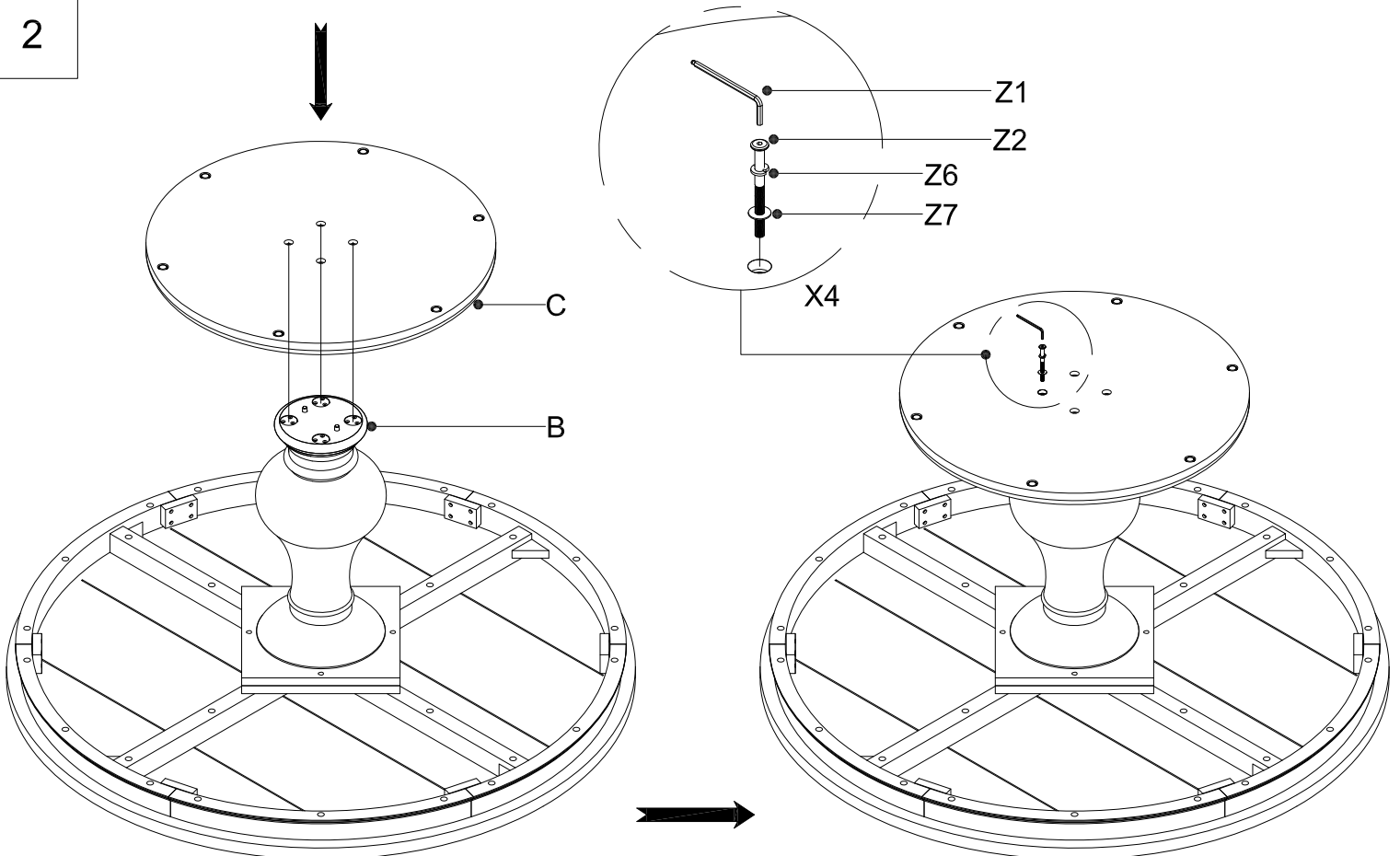

Assembly Instructions

SKU # 51030756

SKU # 51031095

3

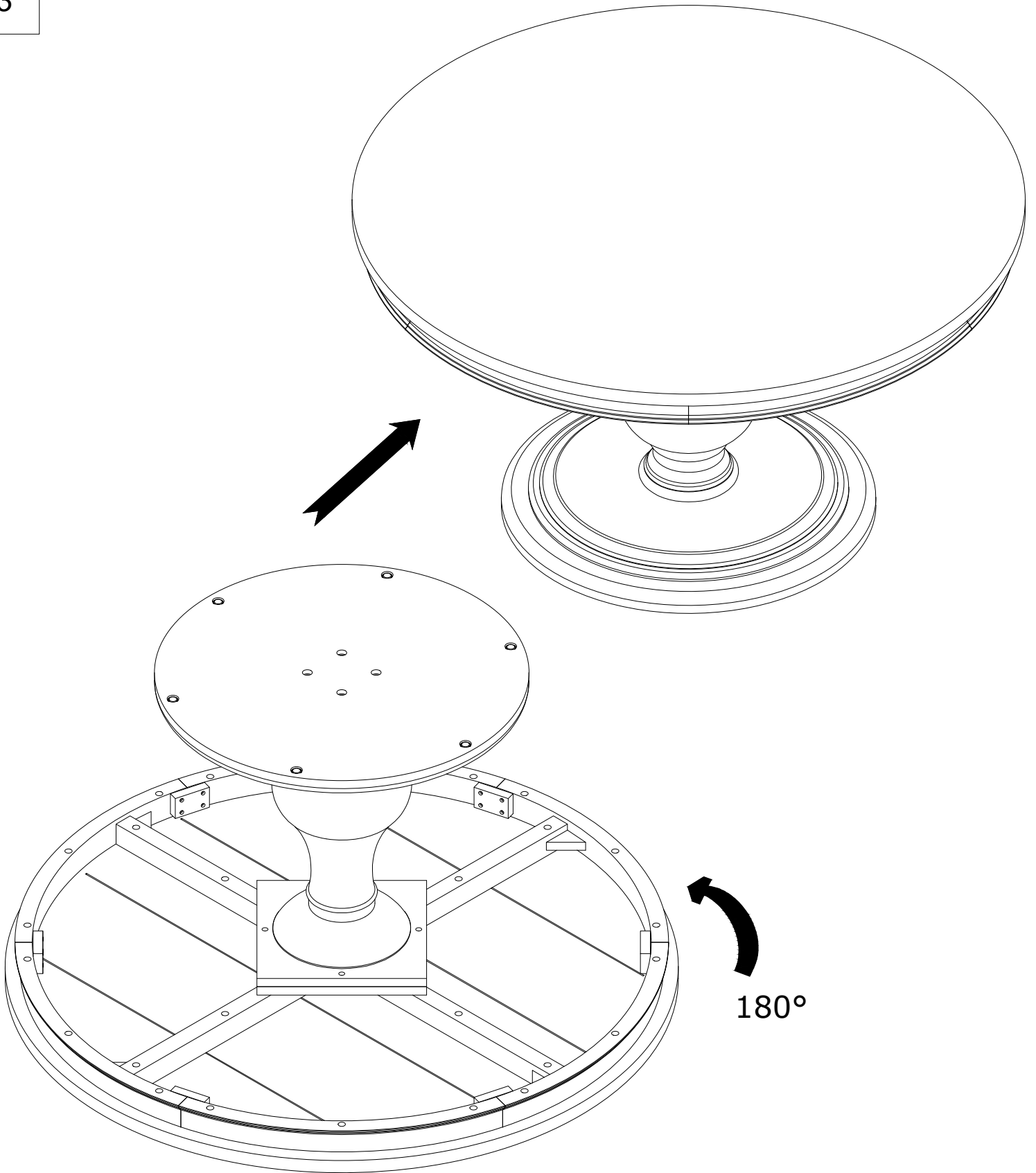

NOTE:

Please adjust the preinstalled levelers at the bottom of the legs to make sure your round table is level.