

Pure & Easy



ASSEMBLY INSTRUCTIONS



NOTICE

IMPORTANT, RETAIN FOR FUTURE REFERENCE: READ CAREFULLY
WICHTIG, FÜR SPÄTERE NACHSCHLAGE AUFBEWAHREN: SORGFÄLTIG LESEN
IMPORTANTE, GUARDAR PARA REFERENCIA POSTERIOR: LEER ATENTAMENTE
IMPORTANTE, CONSERVARE PER RIFERIMENTI FUTURI: LEGGERE ATTENTAMENTE
IMPORTANT, À CONSERVER POUR RÉFÉRENCE FUTURE : LIRE ATTENTIVEMENT

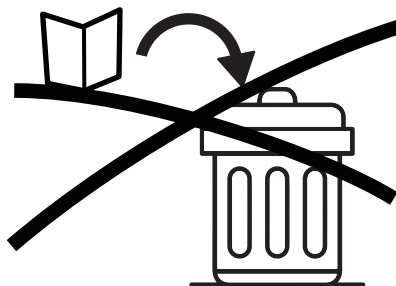
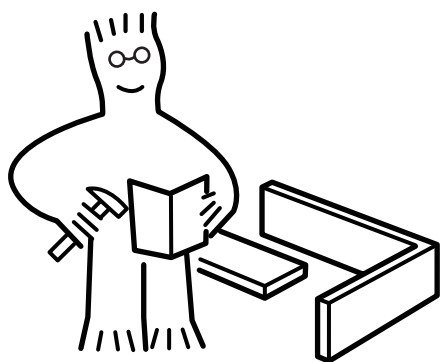

Assemble on a flat, clean and soft surface.

Auf einer flachen, sauberen und weichen Oberfläche zusammenbauen.

Assembler sur une surface plate, propre et douce.

Assemblare su una superficie piatta, pulita e morbida.

Ensamblar sobre una superficie plana, limpia y suave.

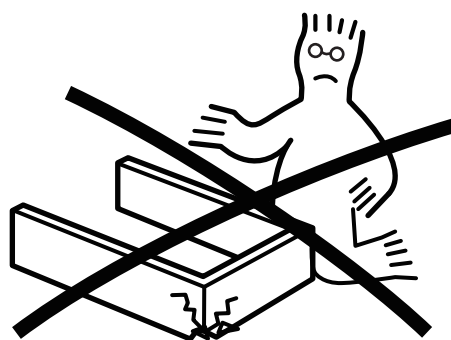
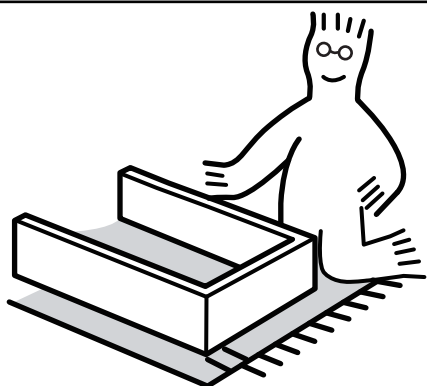

Professional installation is highly recommended.

Eine professionelle Installation wird dringend empfohlen.

Une installation professionnelle est fortement recommandée.

Si raccomanda vivamente l'installazione professionale.

Se recomienda altamente la instalación profesional.



Periodically check that all components are tightly secured.

Überprüfen Sie Regelmäßig, Dass Alle Komponenten Fest Gesichert Sind.

Vérifiez Périodiquement Que Tous Les Composants Sont Bien Fixés.

Controllare Periodicamente Che Tutti I Componenti Siano Ben Fissati.

Verifique Periódicamente Que Todos Los Componentes Estén Bien Asegurados.

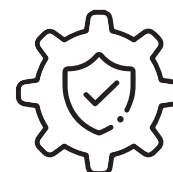

It is recommended that multiple people assemble this product.

Es wird empfohlen, dass mehrere Personen dieses Produkt zusammenbauen.

Il est recommandé que plusieurs personnes assemblent ce produit.

Si raccomanda che più persone assemblino questo prodotto.

Se recomienda que varias personas ensamben este producto.

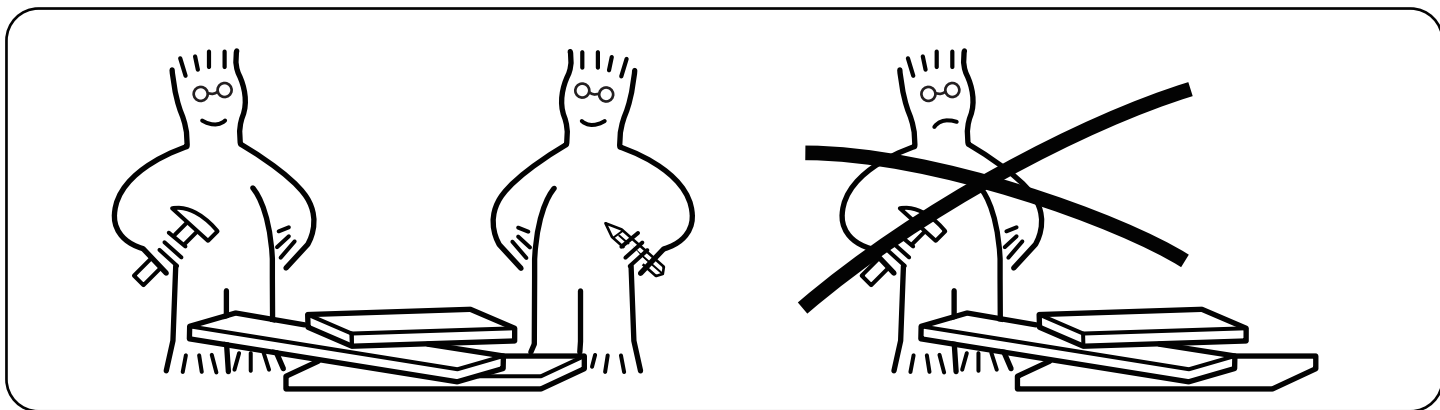

Please have the following auxiliary tools ready:

Bitte halten Sie folgende Hilfswerkzeuge bereit:

Veillez préparer les outils auxiliaires suivants :

Si prega di avere pronti i seguenti strumenti ausiliari:

Por favor, tenga listas las siguientes herramientas auxiliares:

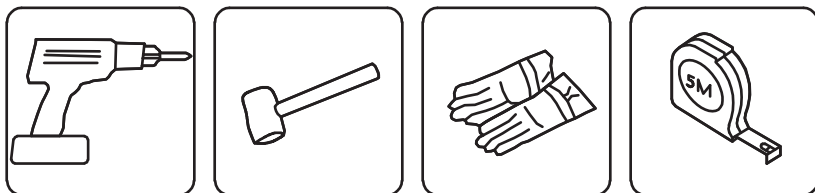

USING CAM LOCK AND QUICKFIT
VERWENDUNG VON NOCKENSCHLOSS UND QUICKFIT
UTILISATION DE SERRURE À CAME ET QUICKFIT
USO DI SERRATURA A LEVA E QUICKFIT
USANDO EL CIERRE DE LEVA Y QUICKFIT

Tighten QuickFit until the shoulder is flush with the panel. Do not overtighten or undertighten.
 Ziehen Sie den Quickfit an, bis die Schulter bündig mit der Platte ist. Nicht zu fest oder zu locker anziehen.
 Serrez le quickfit jusqu'à ce que l'épaulement soit affleurant avec le panneau. Ne serrez pas trop ou trop peu.
 Stringere il quickfit fino a quando la spalla è a filo con il pannello. Non stringere troppo o troppo poco.
 Apriete el quickfit hasta que el hombro esté al ras con el panel. No apriete demasiado ni demasiado poco.

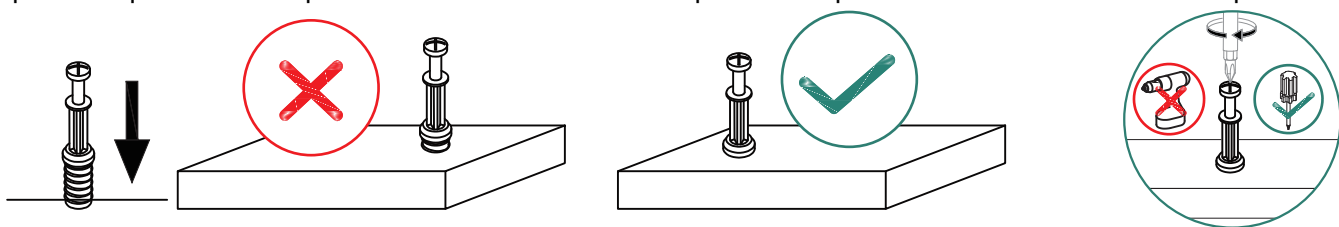

When fitting the cam lock, ensure the starting position is correct before inserting the connecting QuickFit.

Stellen Sie beim Einbau des Nockenschloss sicher, dass die Startposition korrekt ist, bevor Sie den verbindenden Quickfit einsetzen.

Lors de la pose du serrure à came, assurez-vous que la position de départ est correcte avant d'insérer le quickfit de connexion.

Quando si monta il serratura a leva, assicurarsi che la posizione di partenza sia corretta prima di inserire il quickfit di collegamento.

Al instalar el cierre de leva, asegúrese de que la posición inicial sea correcta antes de insertar el quickfit de conexión.

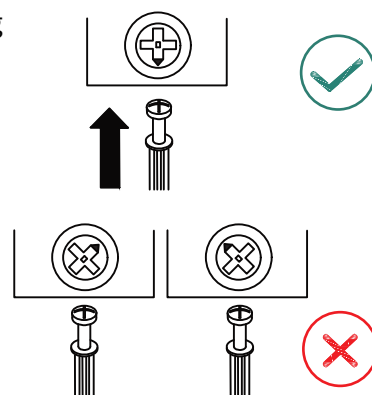

The QuickFit head should be in the center of the cam lock when the two panels are joined. The cam lock should be inserted before the QuickFit. Turn the cam lock clockwise to tighten.

Der Quickfit-Kopf sollte sich in der Mitte des Nockenschloss befinden, wenn die beiden Platten verbunden sind. Der Nockenschloss sollte vor dem Quickfit eingesetzt werden. Drehen Sie den Nockenschloss im Uhrzeigersinn, um ihn zu befestigen.

La tête du quickfit doit être au centre du serrure à came lorsque les deux panneaux sont assemblés. Le serrure à came doit être inséré avant le quickfit. Tournez le serrure à came dans le sens des aiguilles d'une montre pour le serrer.

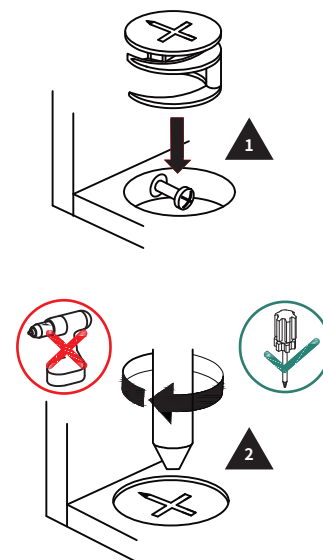

La testa del quickfit dovrebbe essere al centro del serratura a leva quando i due pannelli sono uniti. Il serratura a leva deve essere inserito prima del quickfit. Ruotare il serratura a leva in senso orario per stringere.

La cabeza del quickfit debe estar en el centro del cam lock cuando los dos paneles estén unidos. El cierre de leva debe insertarse antes del quickfit. Gire el cierre de leva en sentido horario para apretar.

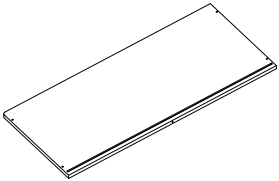
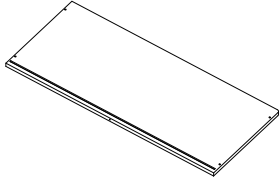
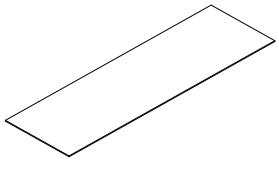
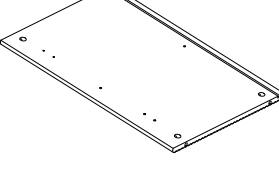
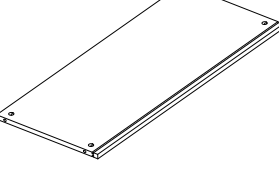
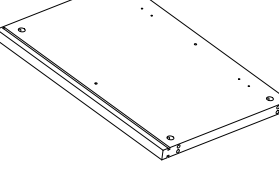
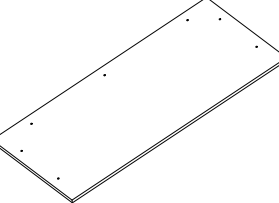
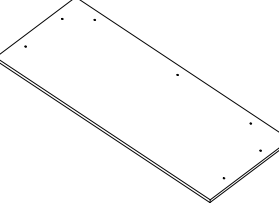
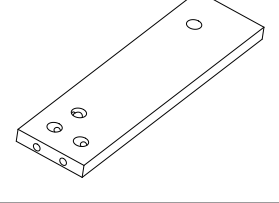
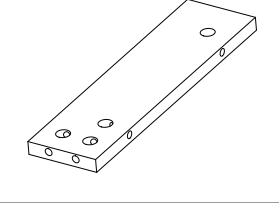
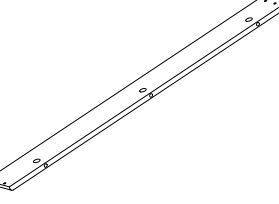
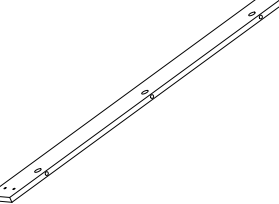
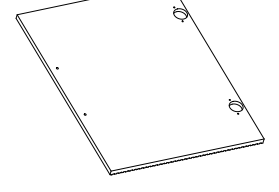

PARTS

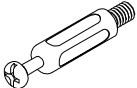
Item no. Nr. N° d'article Articolo No. Artículo No.	Reference Image Referenzbild Image de référence Immagine di riferimento Imagen de referencia	Qty. Menge Qté. Qtà Cant.	Item no. Nr. N° d'article Articolo No. Artículo No.	Reference Image Referenzbild Image de référence Immagine di riferimento Imagen de referencia	Qty. Menge Qté. Qtà Cant.
1		X1	2		X1
3		X4	4		X2
5		X2	6		X1
7		X1	8		X1
9		X2	10		X2
11		X1	12		X1
13		X4			

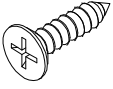
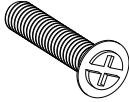
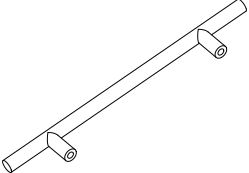
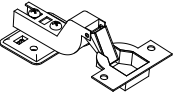
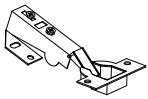
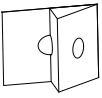
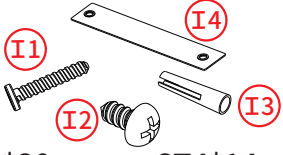
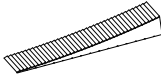
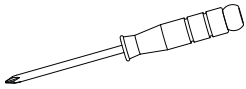
Item no. Nr. N° d'article Articolo No. Artículo No.	Reference Image Referenzbild Image de référence Immagine di riferimento Imagen de referencia	Qty. Menge Qté. Qtà Cant.	Item no. Nr. N° d'article Articolo No. Artículo No.	Reference Image Referenzbild Image de référence Immagine di riferimento Imagen de referencia	Qty. Menge Qté. Qtà Cant.
A		X46	B	 φ15 X 10mm	X46
C	 ST3.5*14mm	X64	D	 M4*25mm	X8
E		X4	F		X4
G		X4	H		X16
I	 ST4*30mm ST4*14mm	X2	J		X2
K		X1			

EXPLODED VIEW

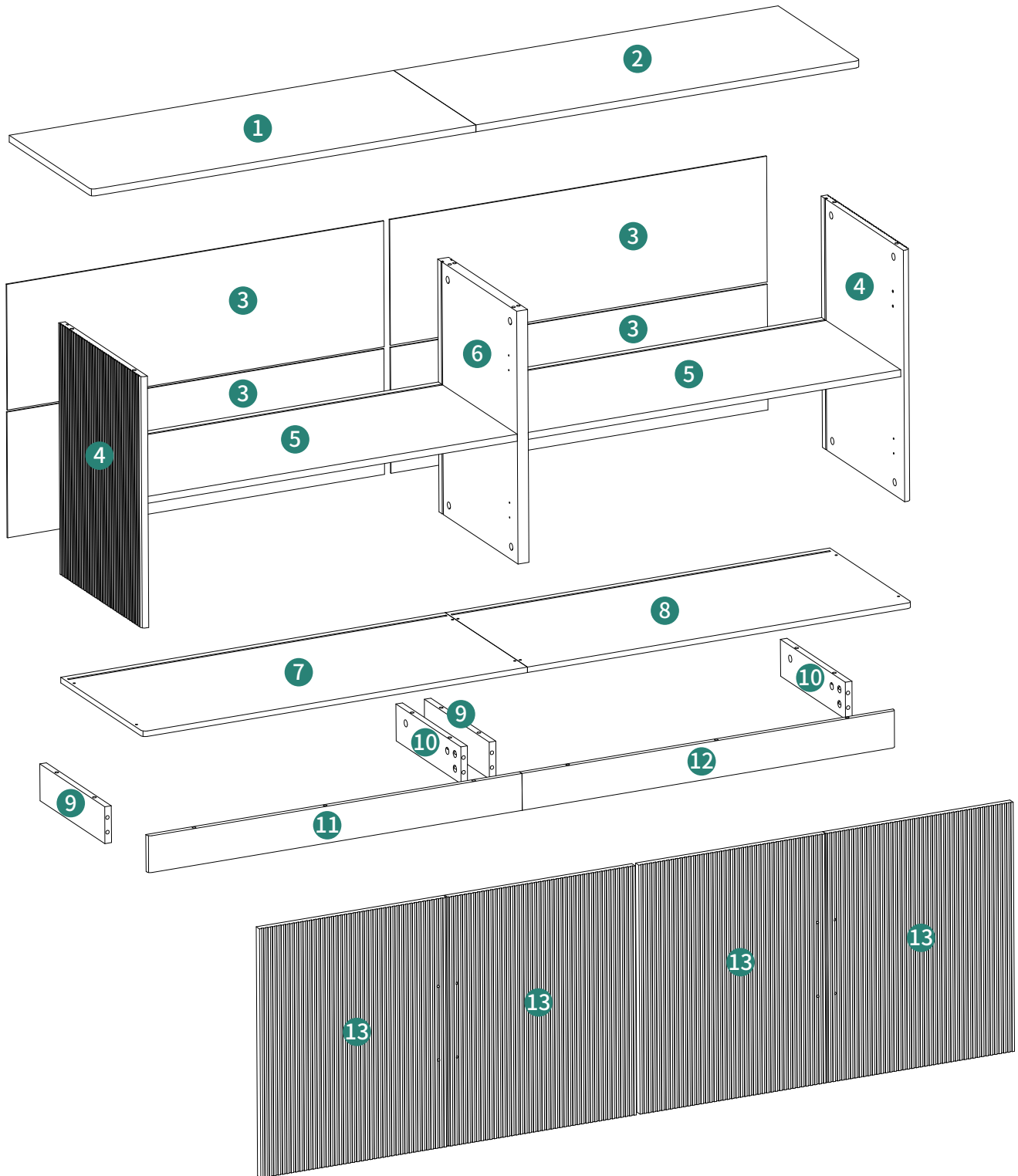

ASSEMBLY

1

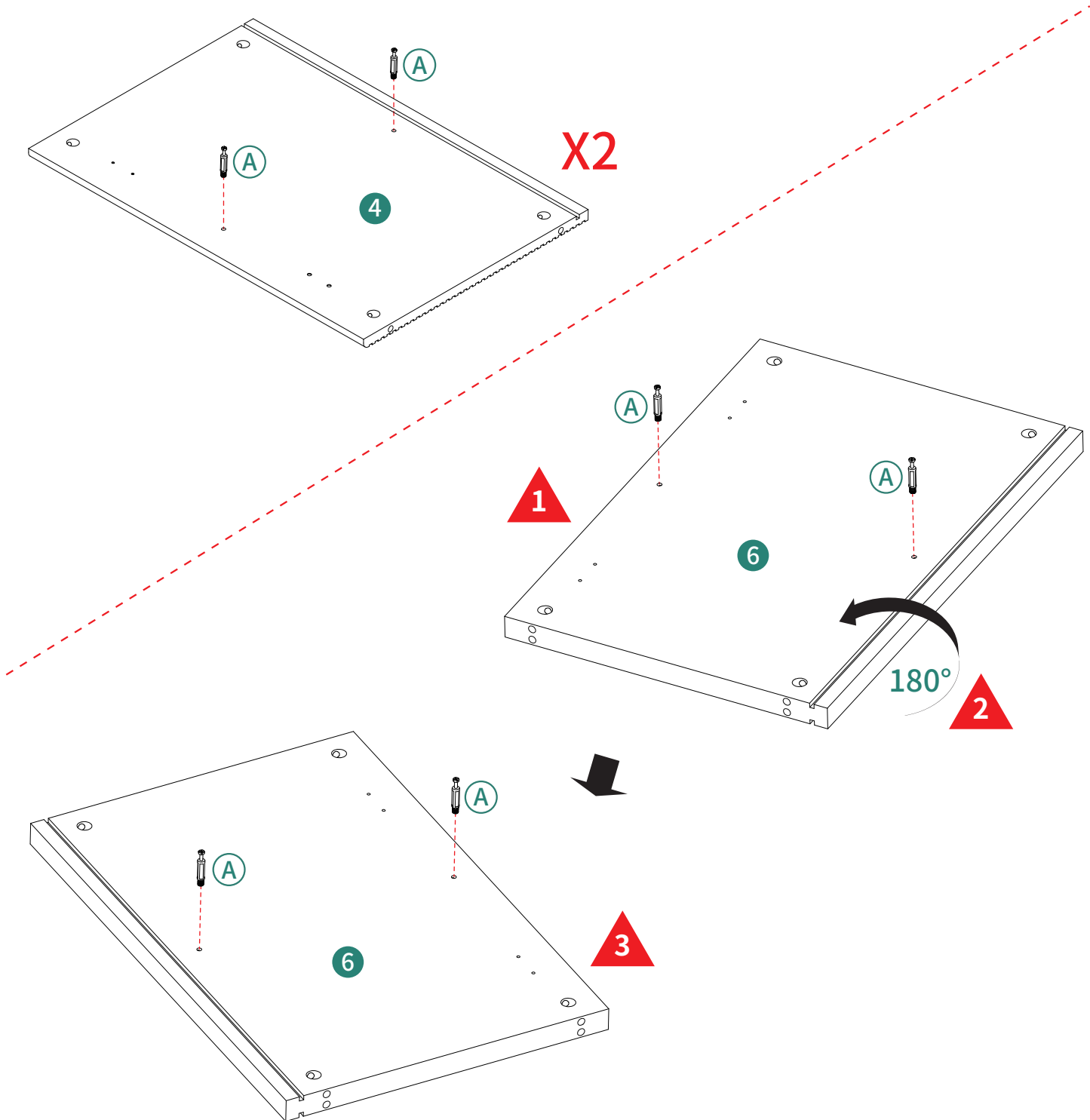
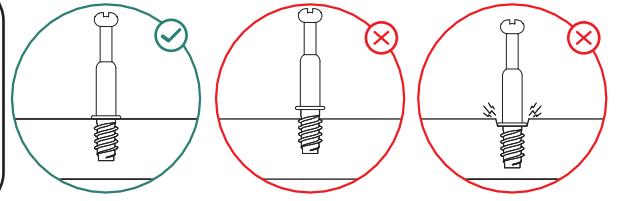
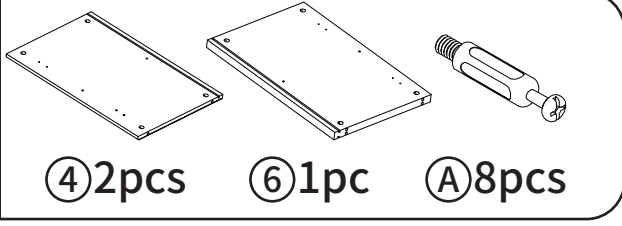

2

⑤ 1pc ② B 2pcs

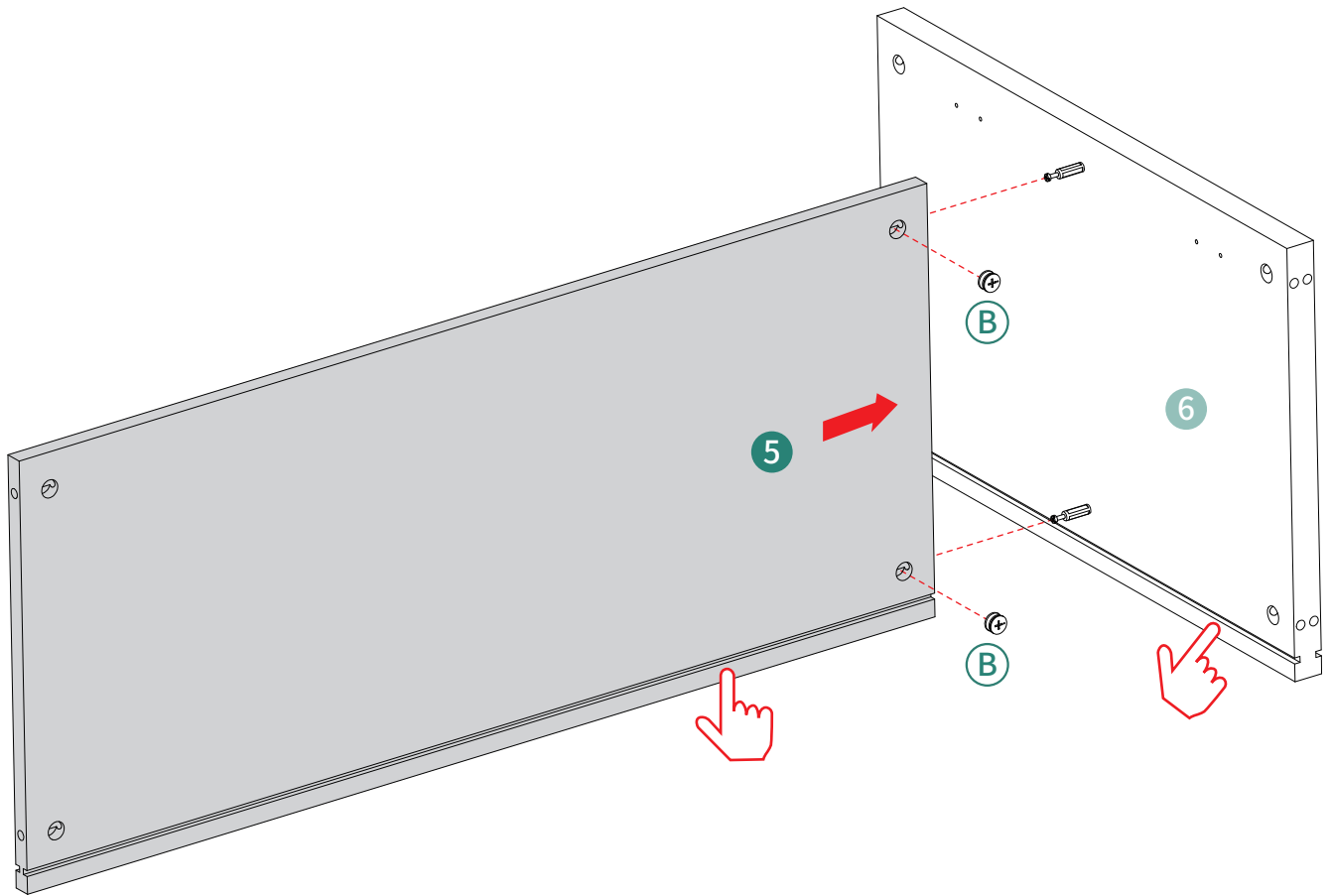

3

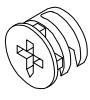

(B) 2pcs

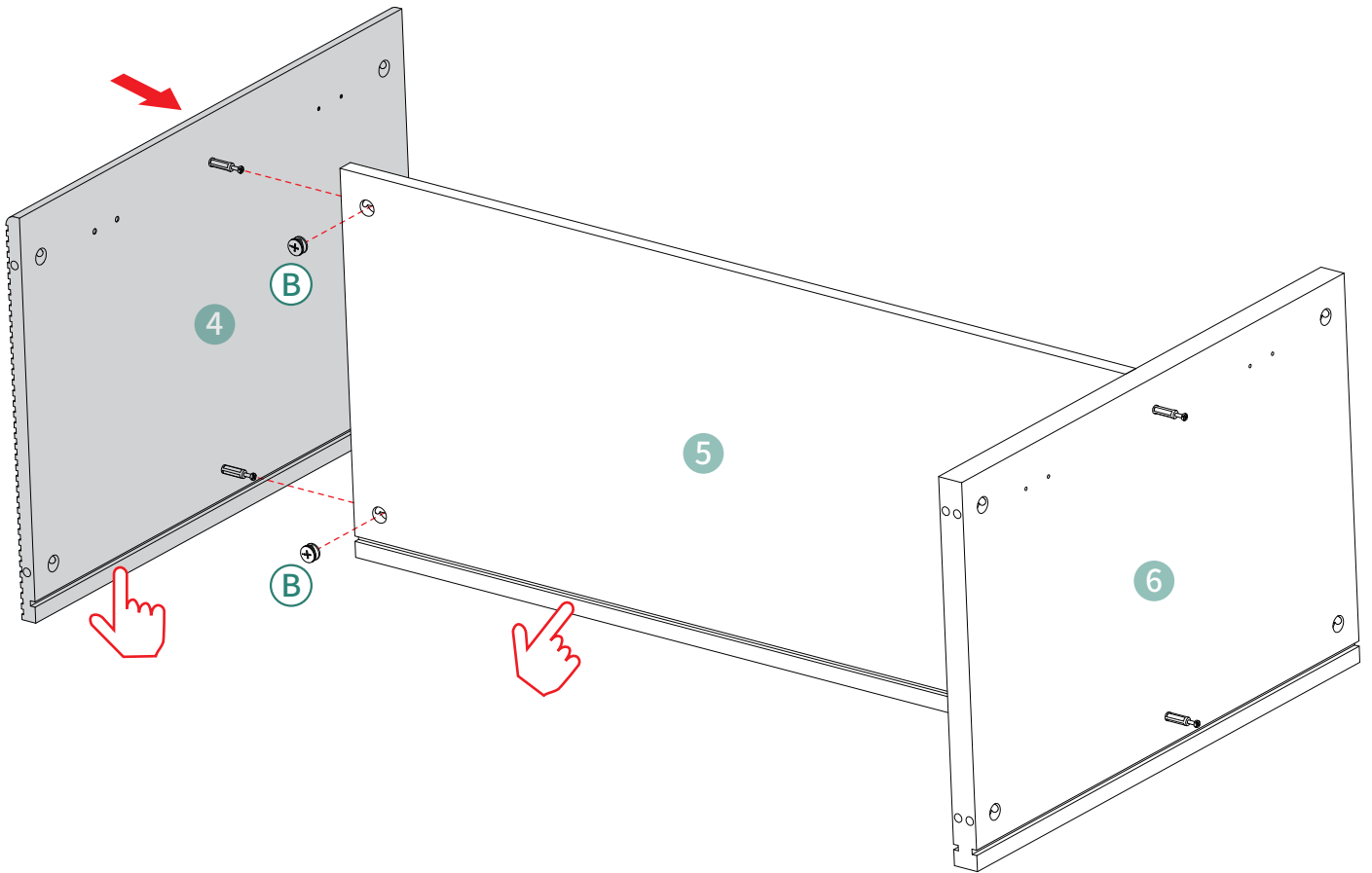

4

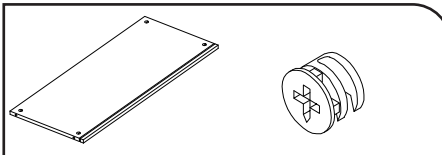

⑤ 1pc ② B 4pcs

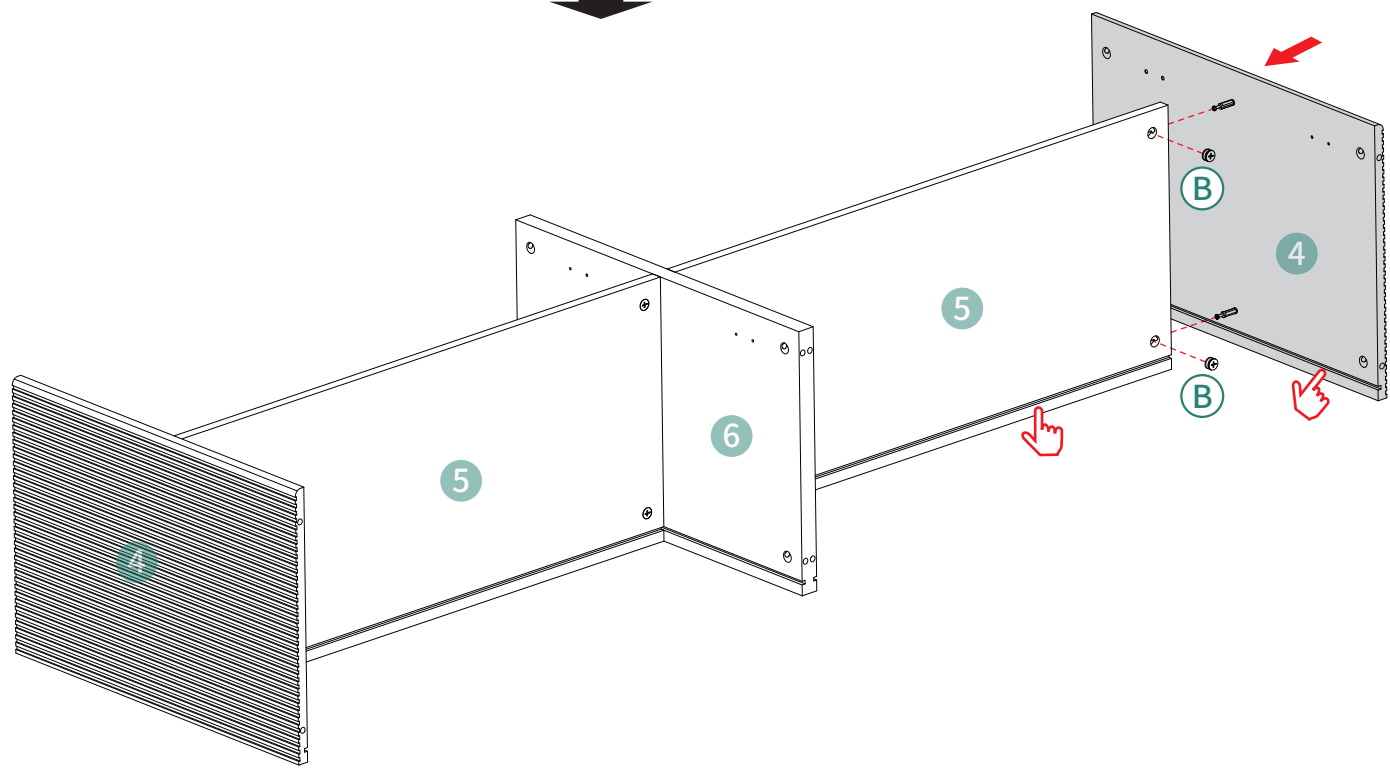
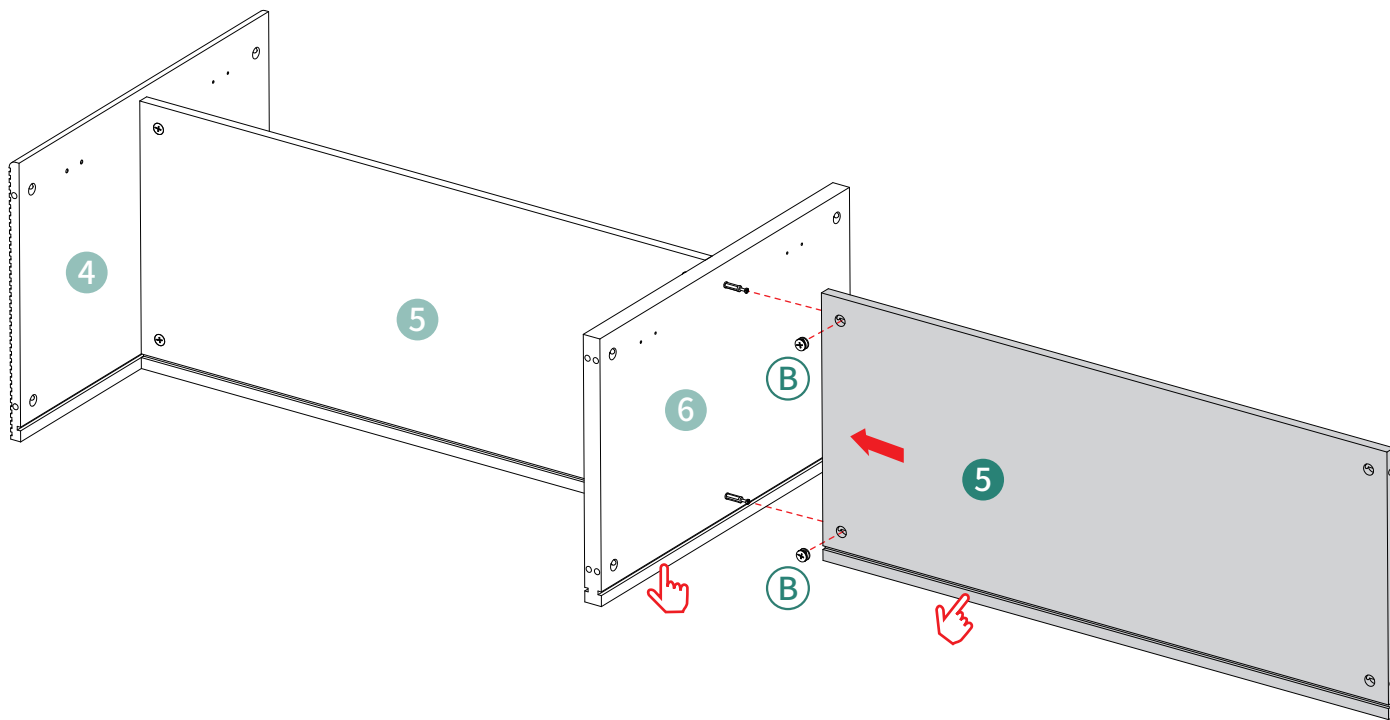

5

Note: Areas marked with a triangle are prone to disconnection before completing step 10. Please handle them with special care in the following steps.

Hinweis: Bereiche, die mit einem Dreieck markiert sind, neigen dazu, sich vor Abschluss von Schritt 10 zu lösen. Bitte gehen Sie in den folgenden Schritten besonders vorsichtig mit ihnen um.

Remarque : Les zones marquées d'un triangle sont sujettes à des déconnexions avant de terminer l'étape 10. Veuillez les manipuler avec un soin particulier dans les étapes suivantes.

Nota: Le aree contrassegnate con un triangolo sono soggette a disconnessione prima di completare il passaggio 10. Si prega di maneggiarle con particolare attenzione nei passaggi successivi.

Nota: Las áreas marcadas con un triángulo son propensas a desconectarse antes de completar el paso 10. Por favor, manéjelas con especial cuidado en los pasos siguientes.

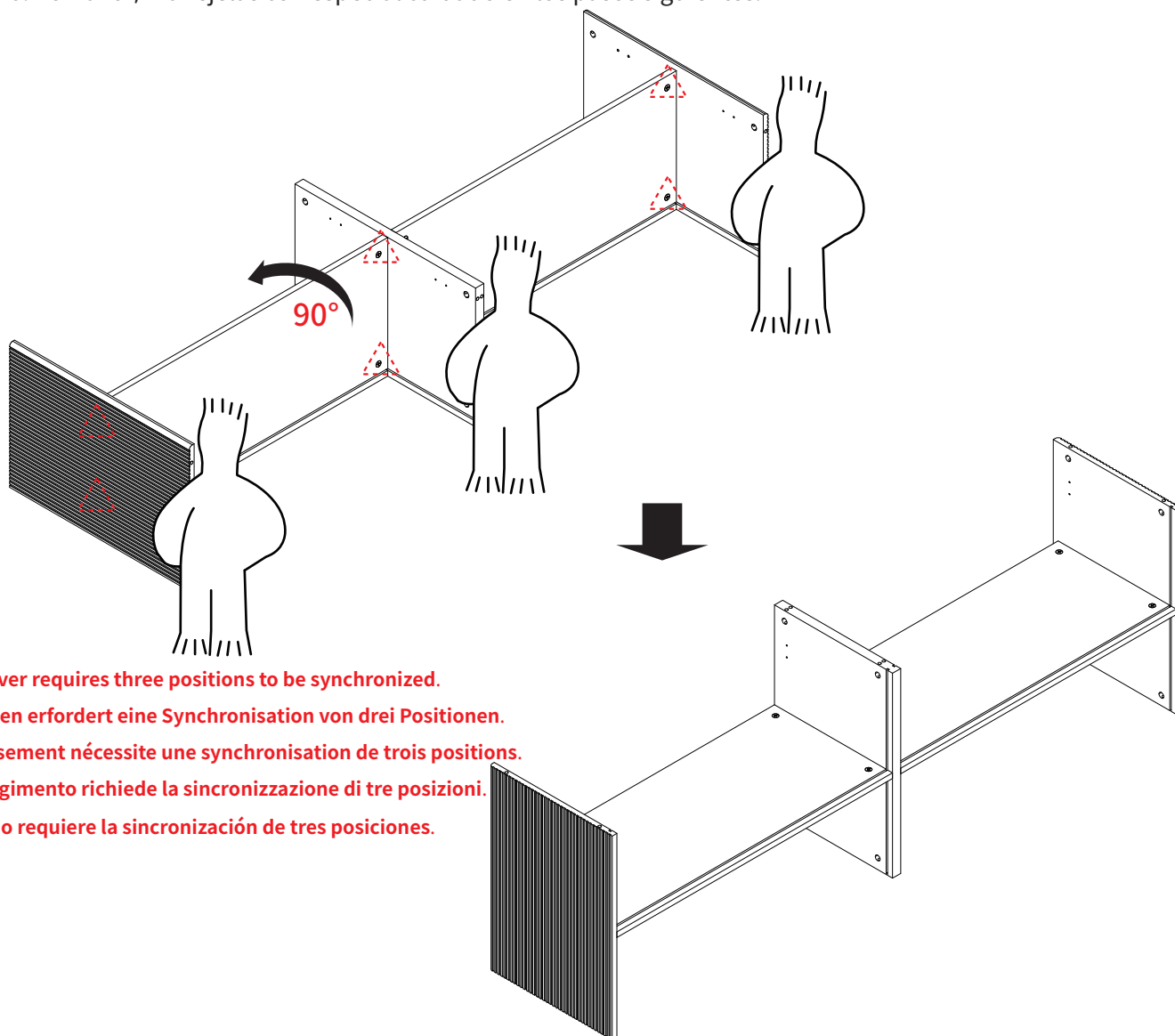

Turning over requires three positions to be synchronized.

Das Wenden erfordert eine Synchronisation von drei Positionen.

Le renversement nécessite une synchronisation de trois positions.

Il capovolgimento richiede la sincronizzazione di tre posizioni.

El volteado requiere la sincronización de tres posiciones.

7

⑦1pc ⑧1pc ⑪1pc ⑫1pc ①22pcs

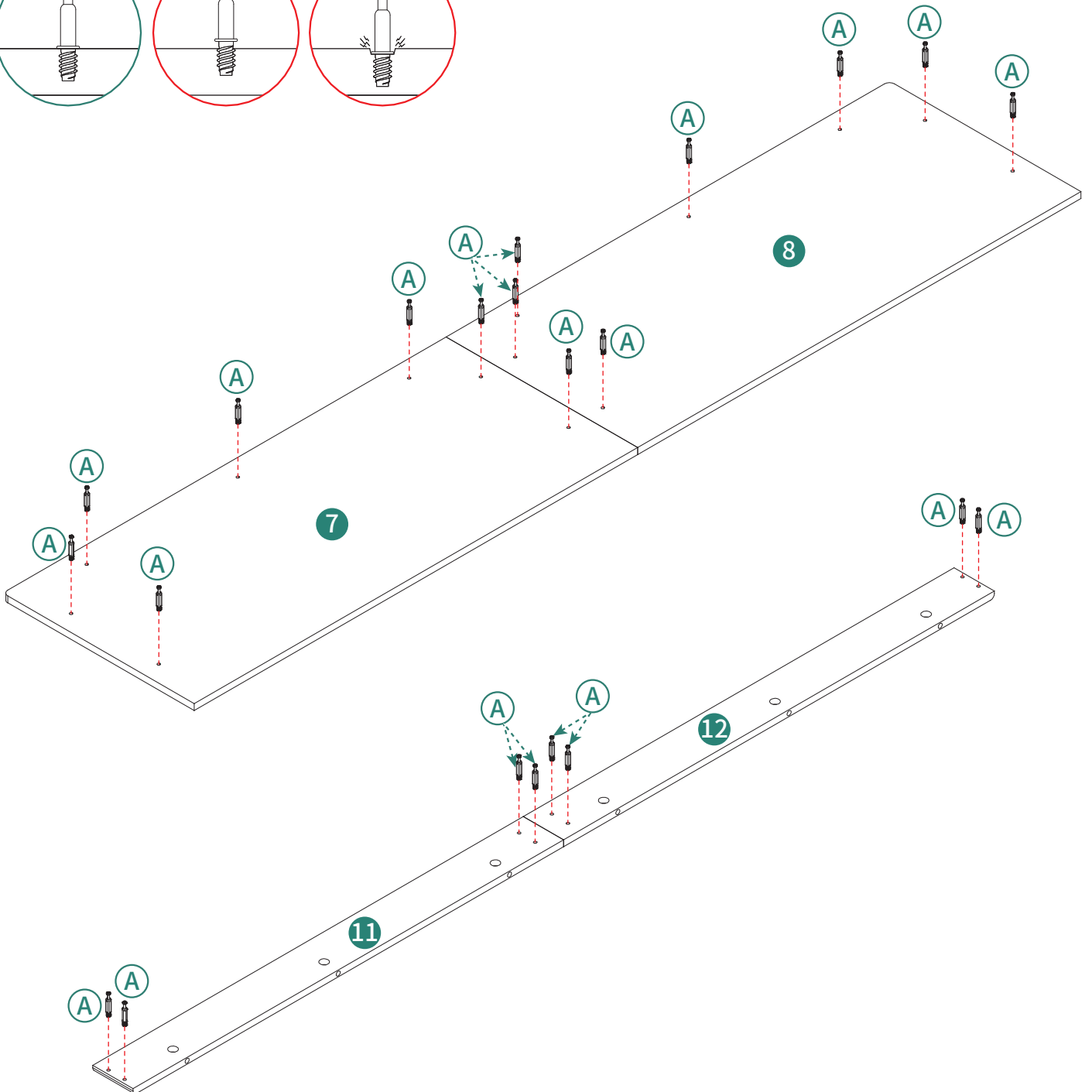
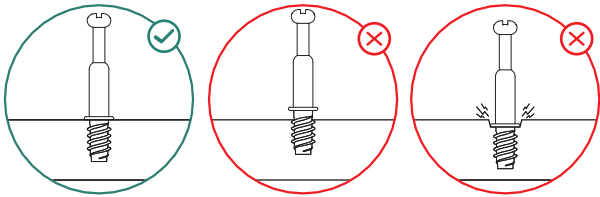

8

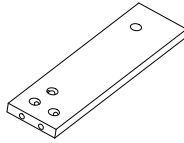

⑨ 2pcs

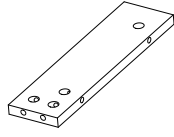

⑩ 2pcs



Ⓑ 8pcs

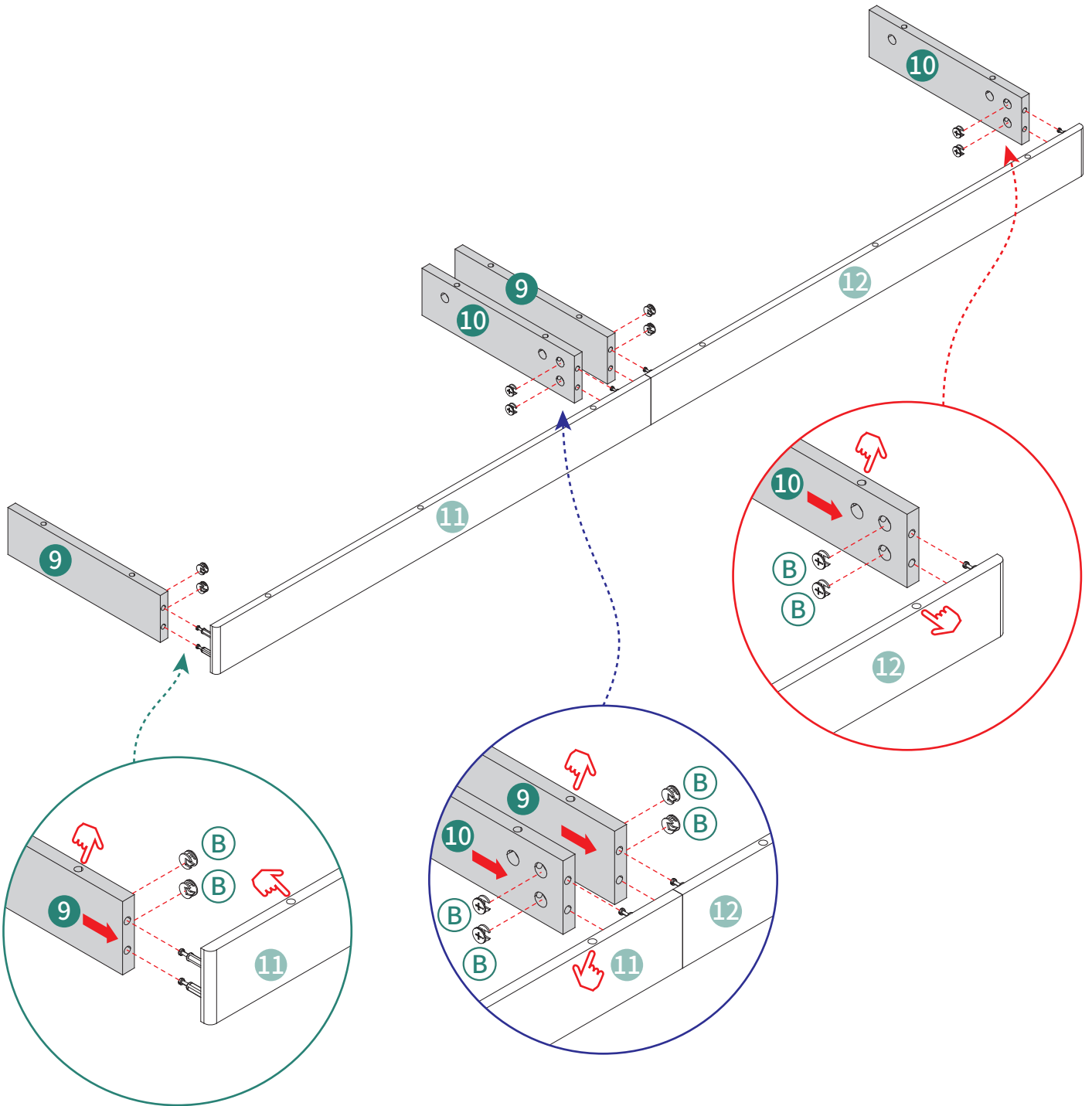

10



ⓑ8pcs

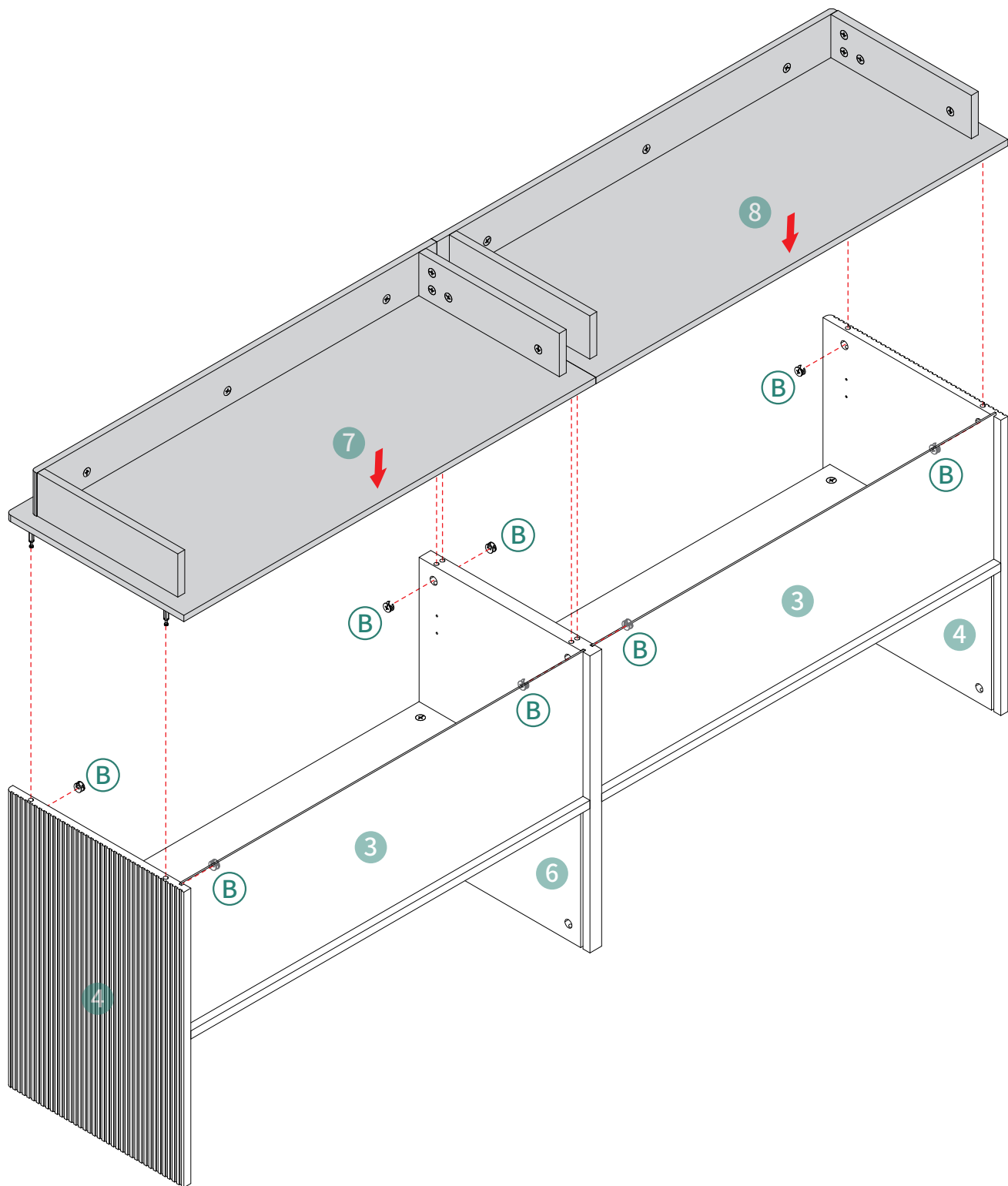

11

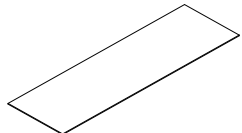

③ 2pcs

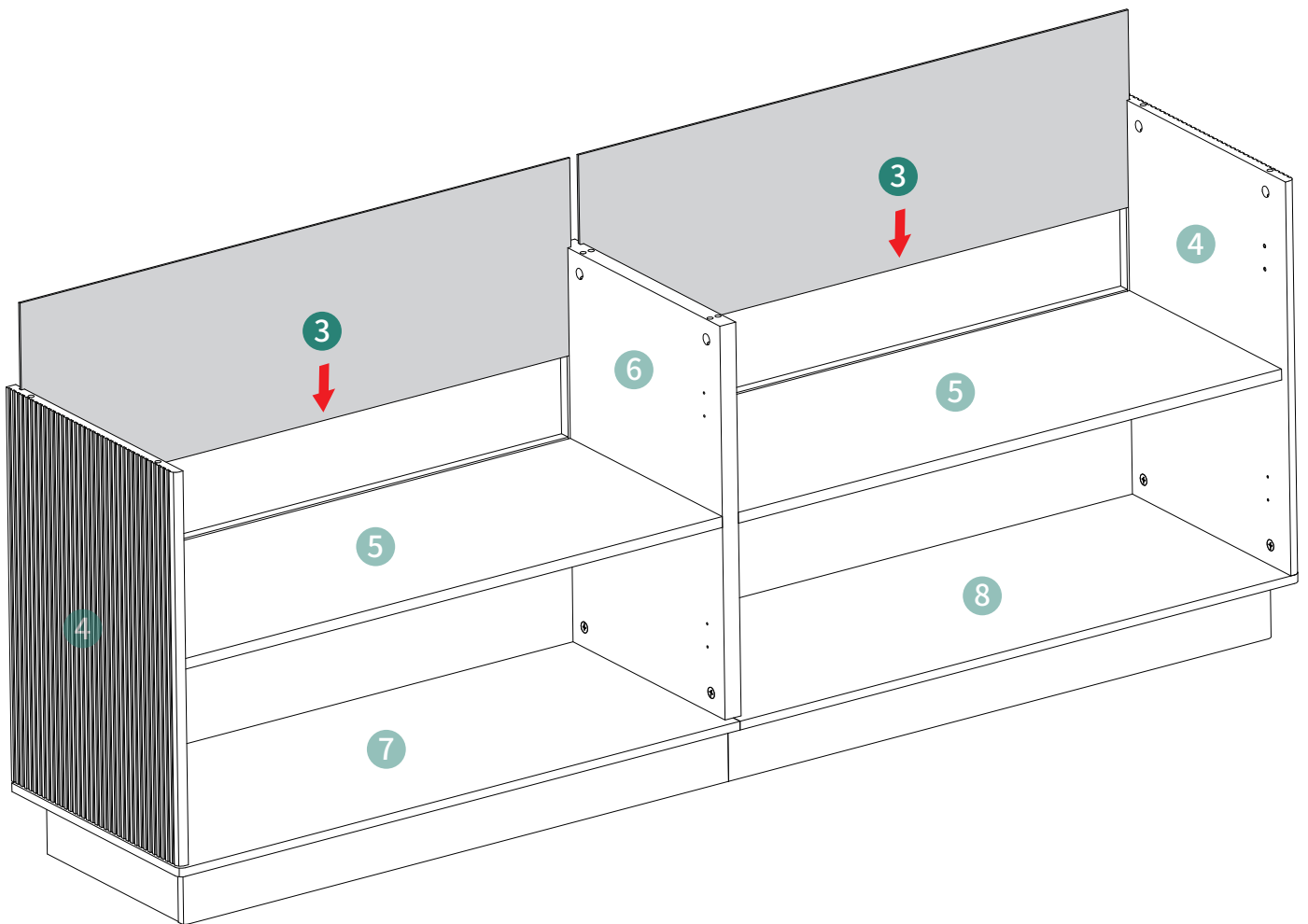

12

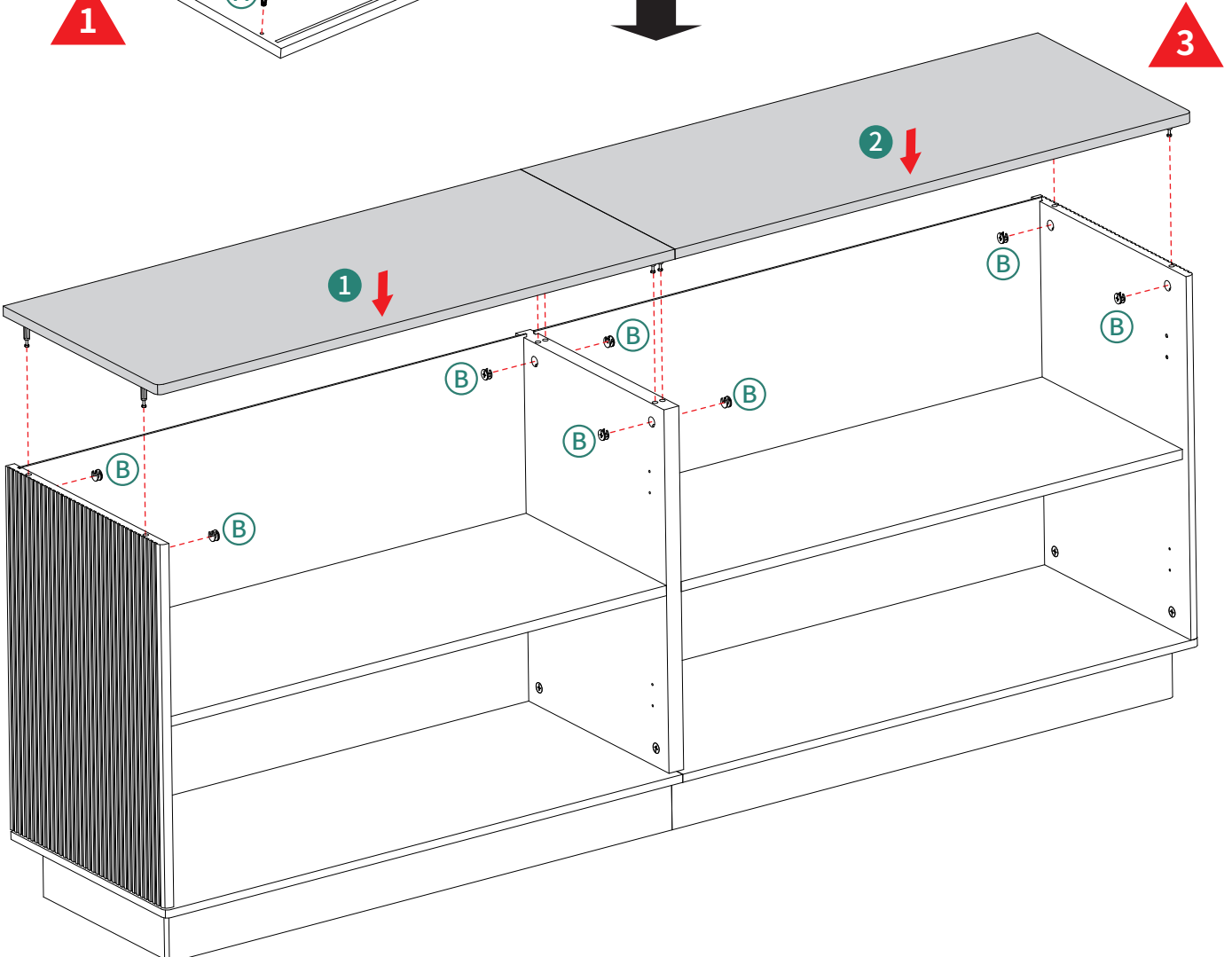
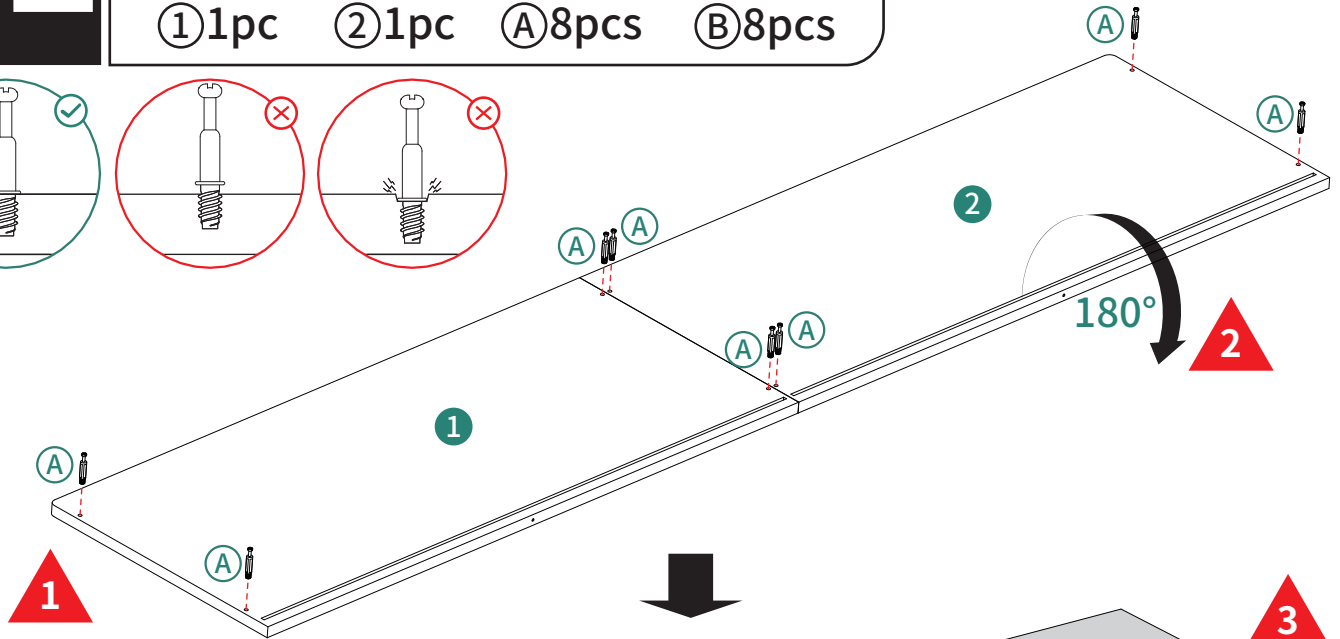
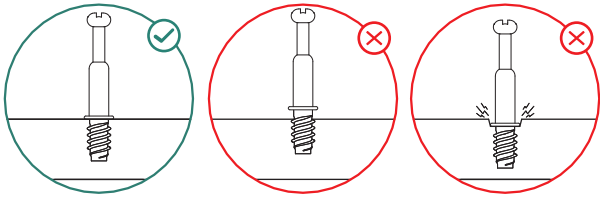
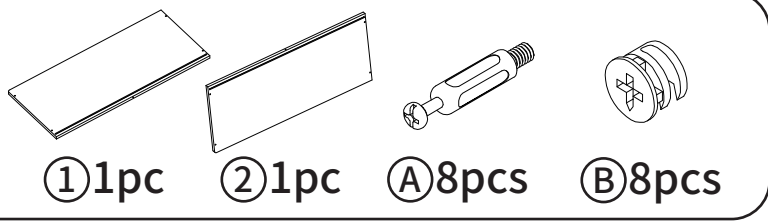

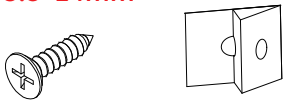
13 ST3.5*14mm

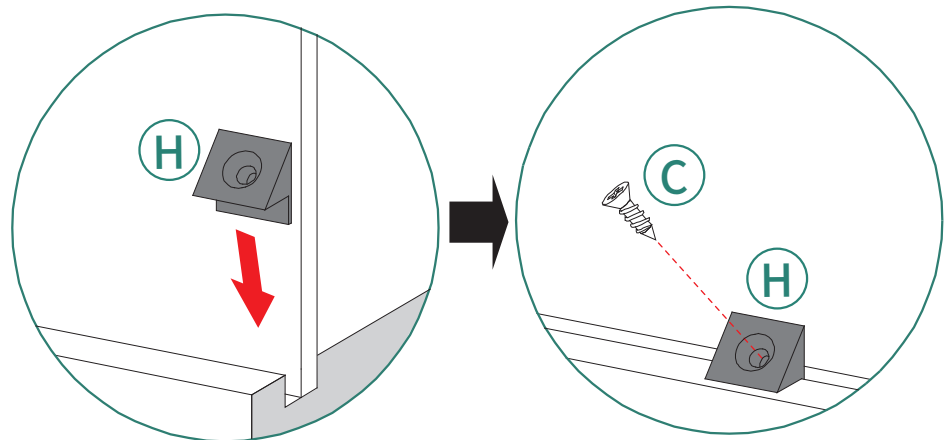
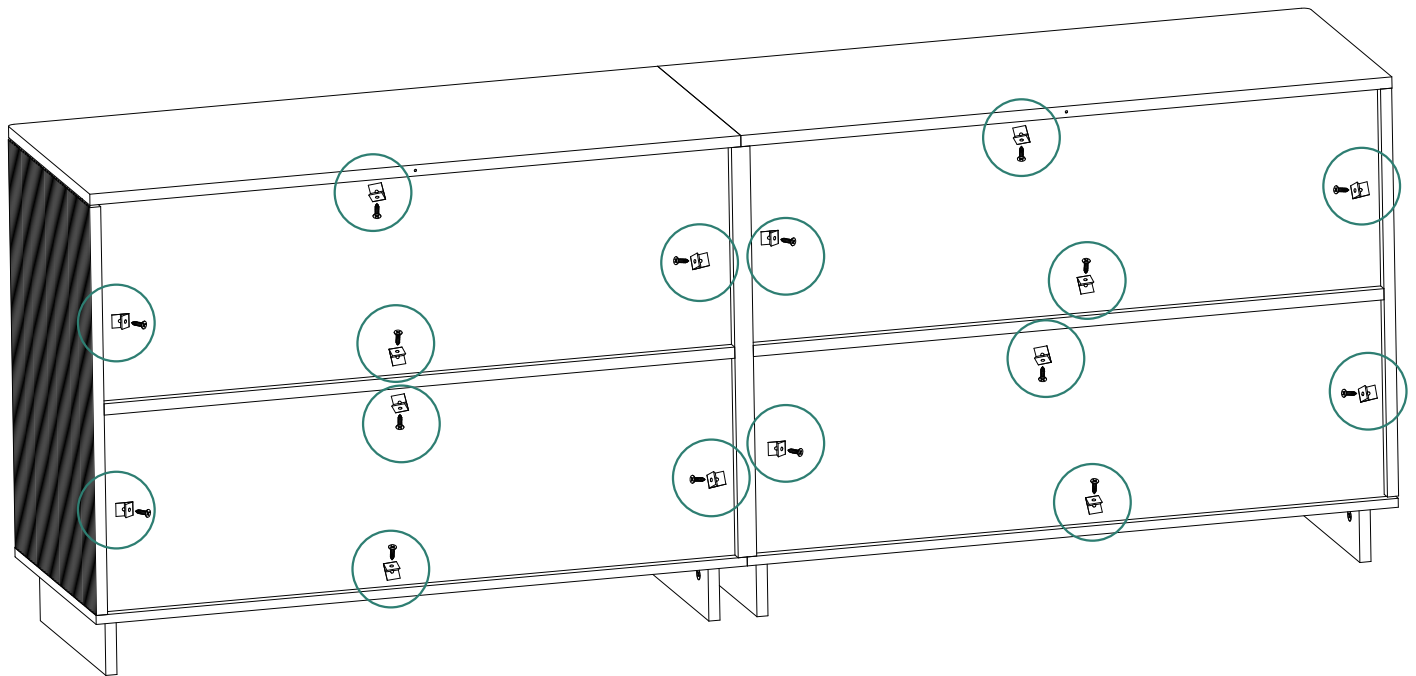
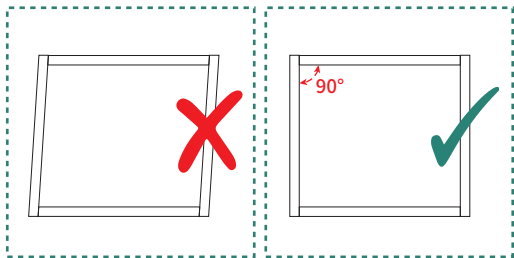
ⓐ16pcs ⓓ16pcs



14

ST4*14mm



I 2pcs

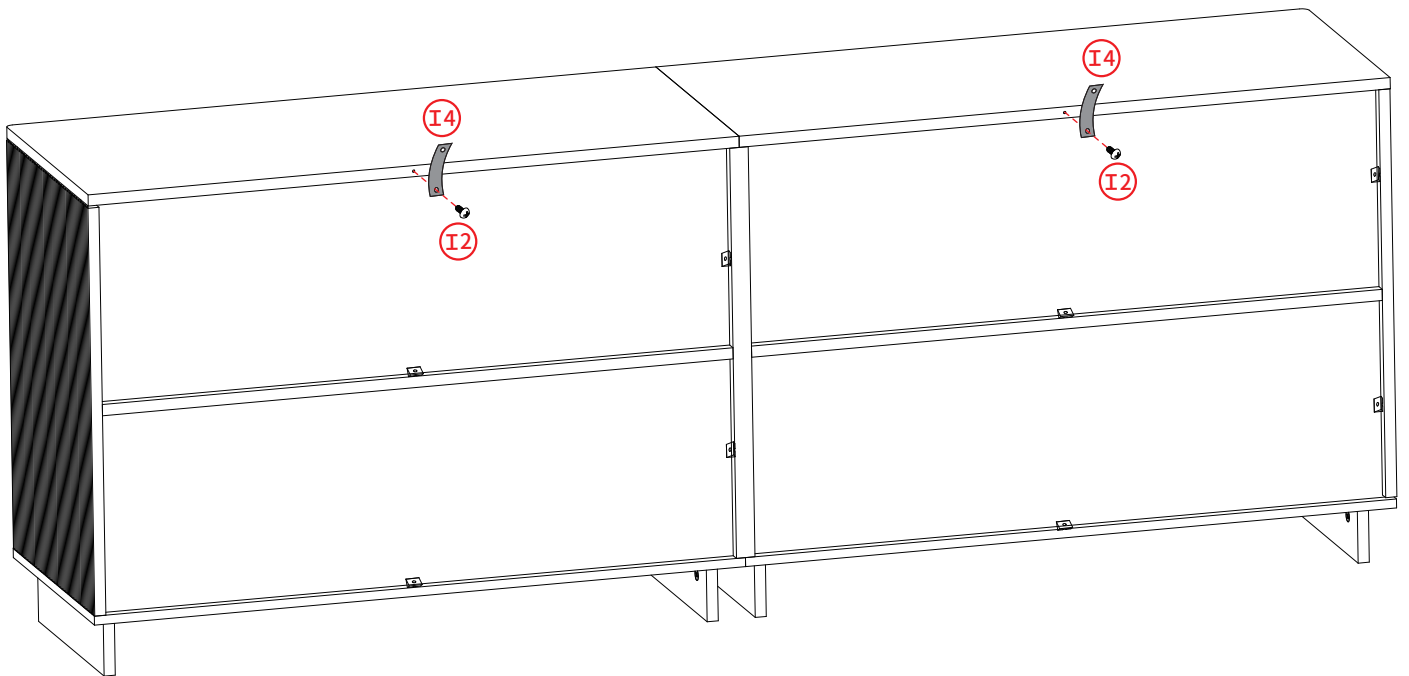
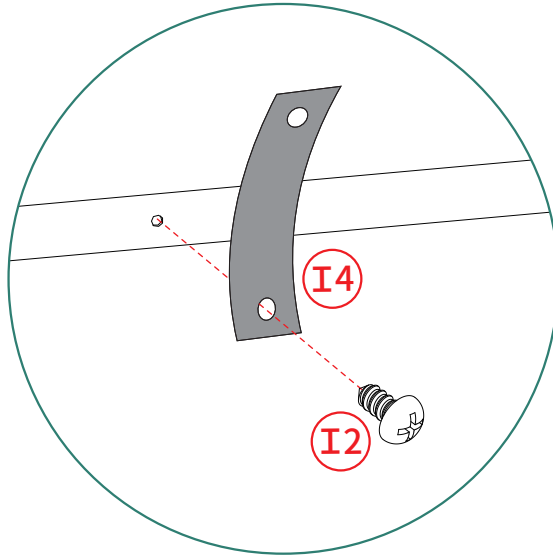

15

X2

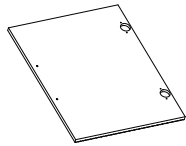

13 2pcs

ST3.5*14mm M4*25mm



C 8pcs

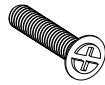

D 4pcs

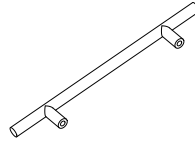

E 2pcs

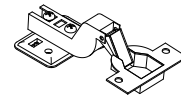

F 4pcs

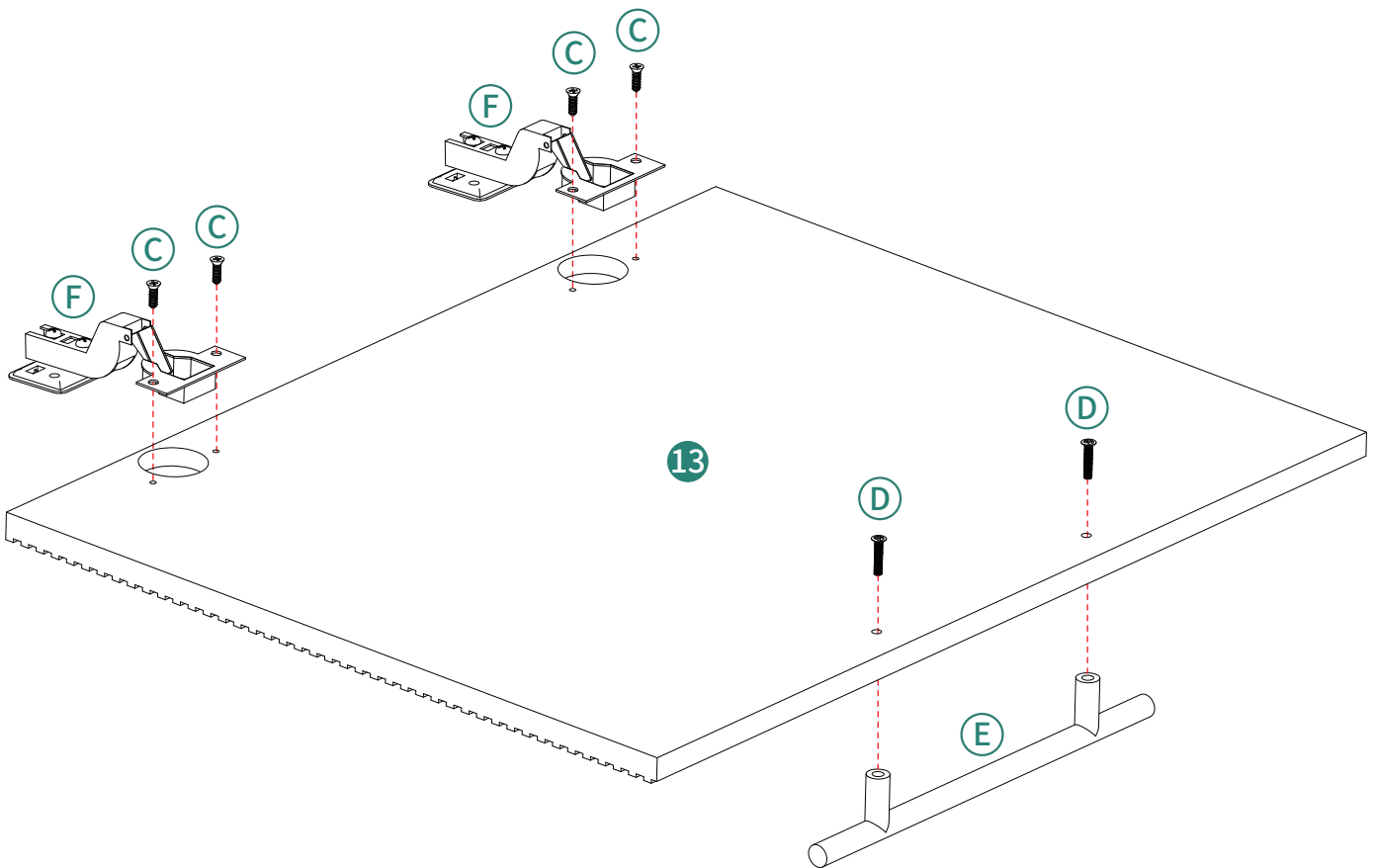
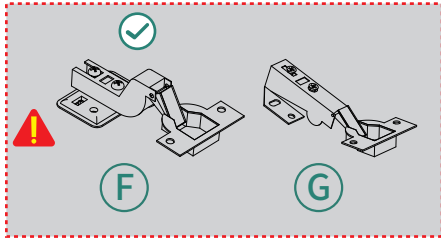

16 ST3.5*14mm
C8pcs

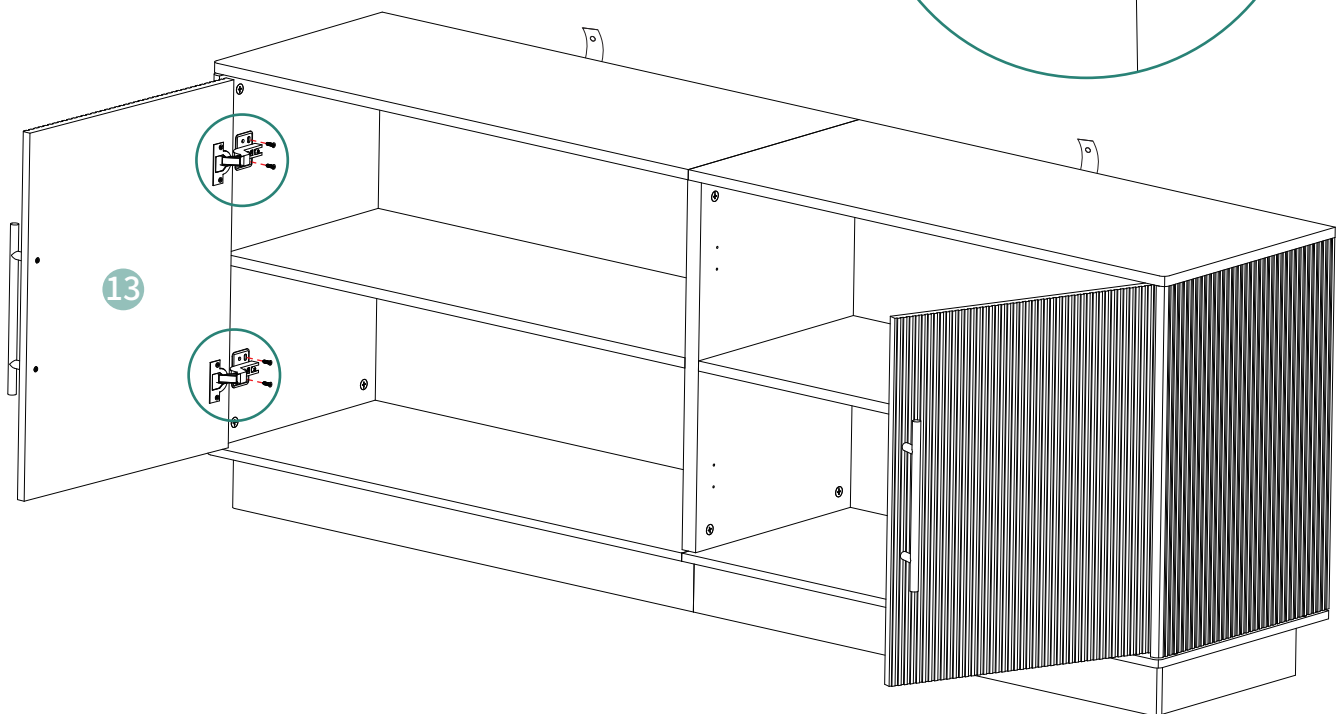
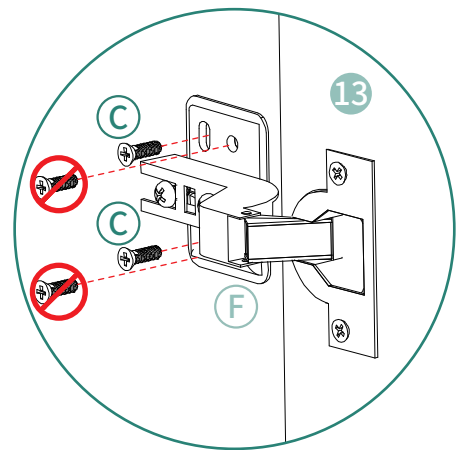
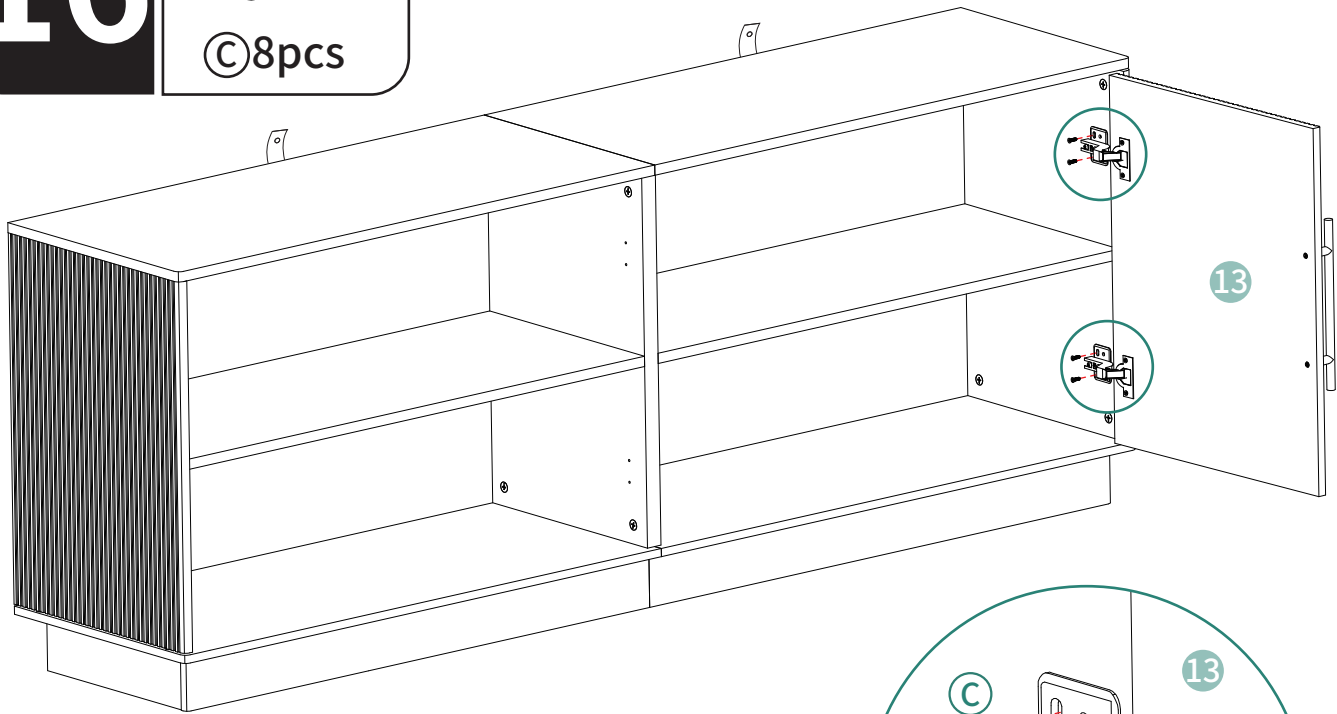

17

X2

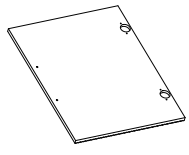

13 2pcs

ST3.5*14mm M4*25mm



C 8pcs

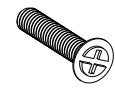

D 4pcs

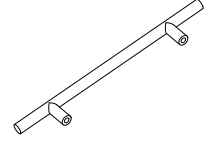

E 2pcs

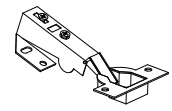

G 4pcs

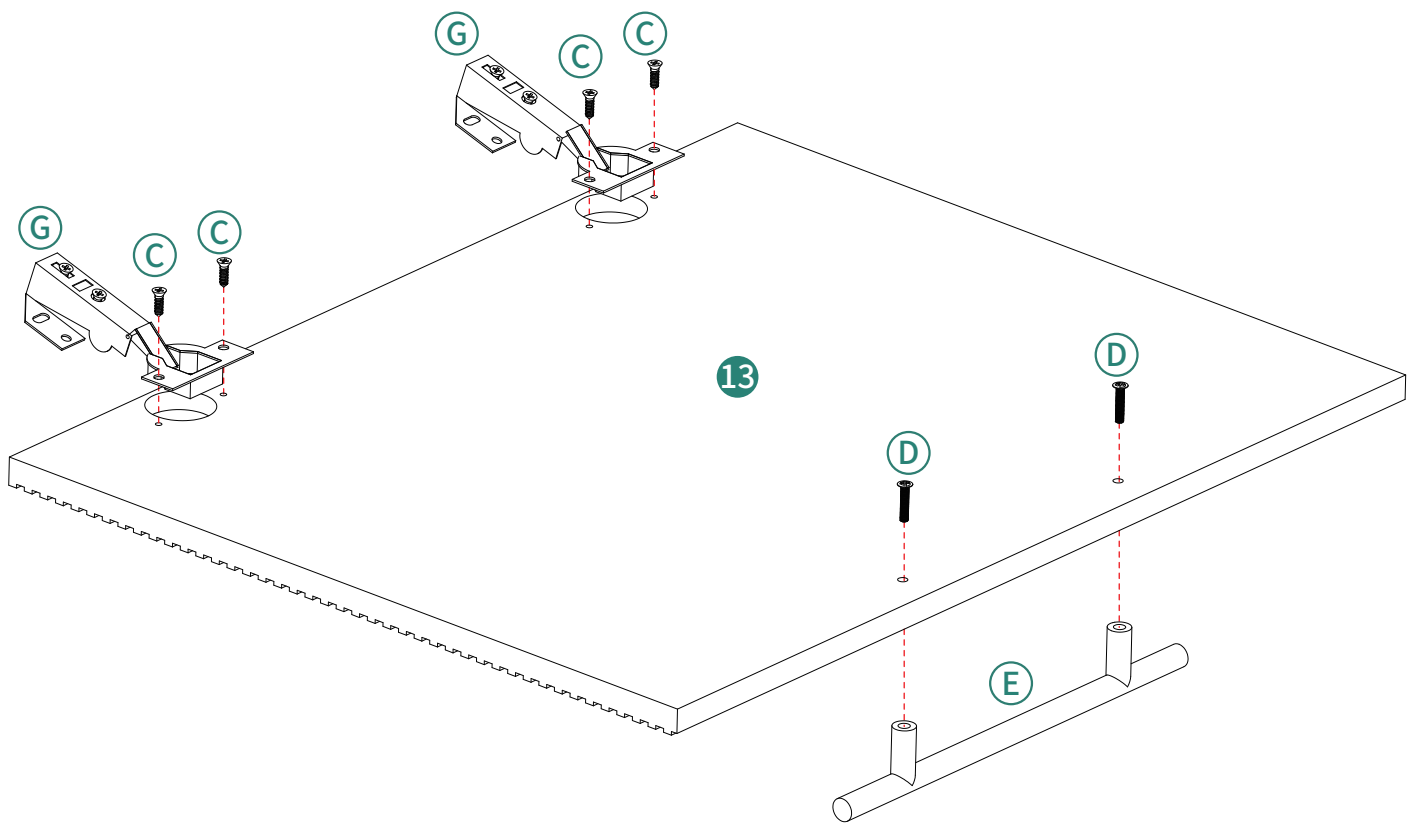
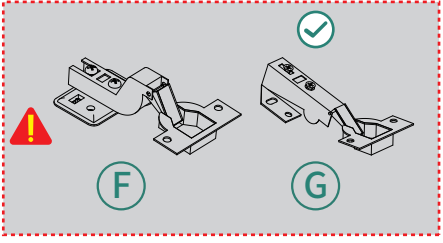

18

ST3.5*14mm



Ⓢ8pcs

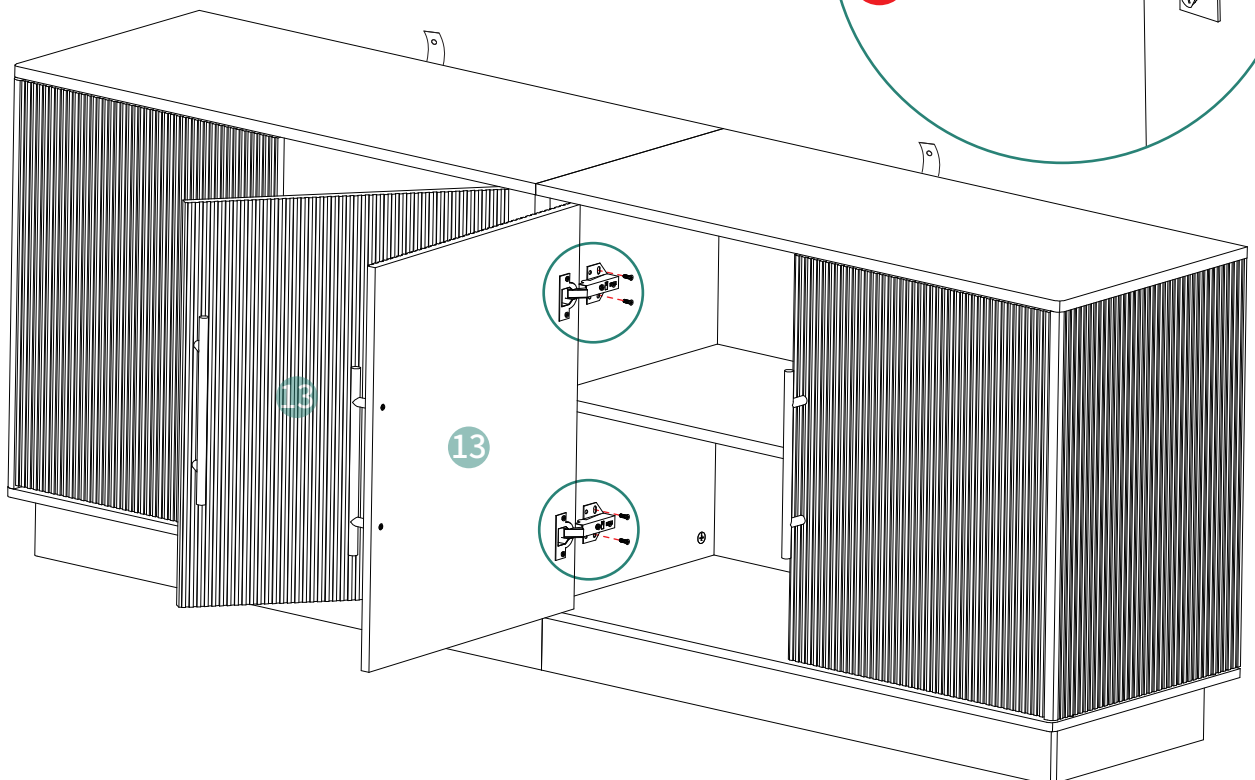
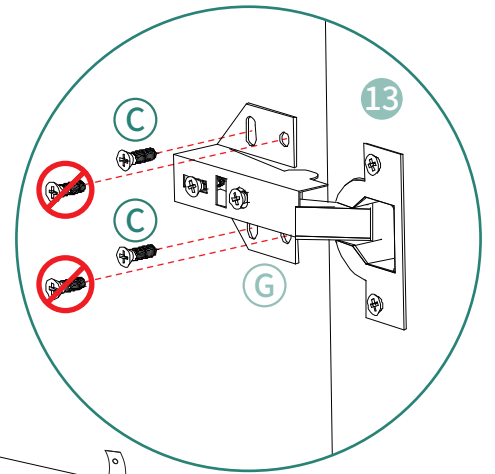
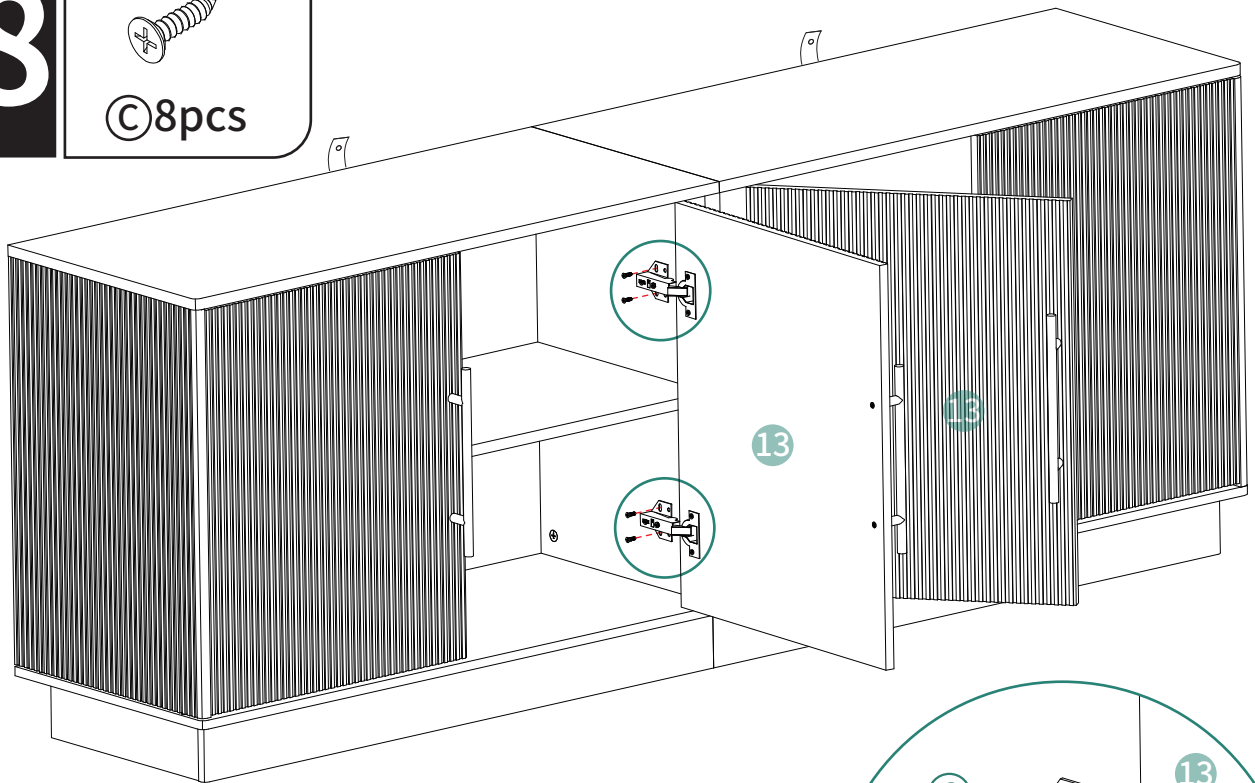

Regarding the installation and adjustment of the door hinge:
Für die Installation und Einstellung des Türscharniers beachten Sie bitte folgendes:
Concernant l'installation et le réglage de la charnière de la porte :
Per quanto riguarda l'installazione e la regolazione della cerniera della porta:
En cuanto a la instalación y ajuste de la bisagra de la puerta:

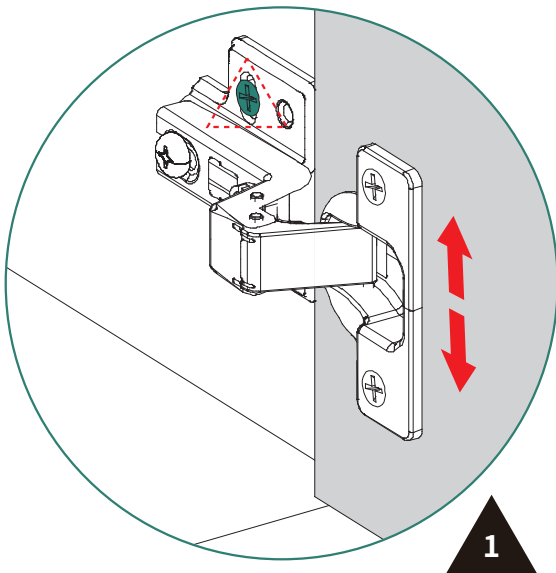

Use the "waist round hole" marked with a triangle to adjust the position of the door panel (ensure that the gap between the door panel and the upper and lower panels is consistent).

Verwenden Sie das mit einem Dreieck markierte "Tailenrundloch", um die Position des Türpanels einzustellen (stellen Sie sicher, dass der Abstand zwischen dem Türpanel und den oberen und unteren Paneelen konsistent ist).

Utilisez le "trou rond de taille" marqué d'un triangle pour régler la position du panneau de la porte (assurez-vous que l'écart entre le panneau de la porte et les panneaux supérieur et inférieur est cohérent).

Utilizzare il "foro rotondo in vita" contrassegnato da un triangolo per regolare la posizione del pannello della porta (assicurarsi che lo spazio tra il pannello della porta e i pannelli superiore e inferiore sia consistente).

Utilizzare il "foro rotondo in vita" contrassegnato da un triangolo per regolare la posizione del pannello della porta (assicurarsi che lo spazio tra il pannello della porta e i pannelli superiore e inferiore sia consistente).

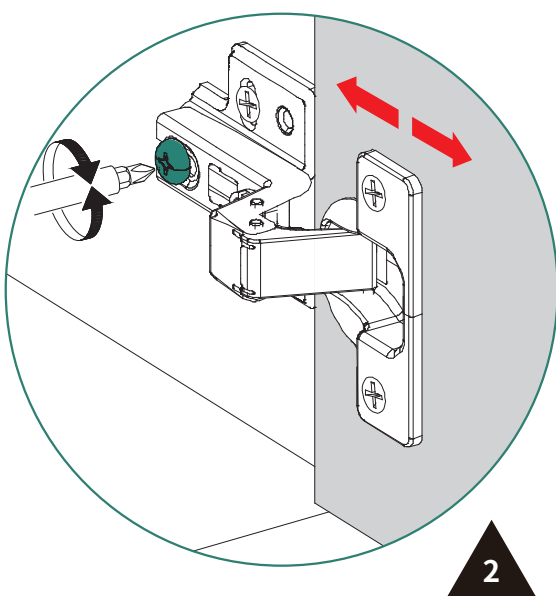

Use the screw at the back end of the hinge to adjust the front and back position of the door panel (ensure that the front of the door panel is in the same plane as the upper and lower panels).

Verwenden Sie die Schraube am hinteren Ende des Scharniers, um die vordere und hintere Position des Türpanels zu justieren (stellen Sie sicher, dass die Vorderseite des Türpanels in der gleichen Ebene wie die oberen und unteren Paneelen liegt).

Utilisez la vis à l'extrémité arrière de la charnière pour régler la position avant-arrière du panneau de la porte (assurez-vous que la partie avant du panneau de la porte est dans le même plan que les panneaux supérieur et inférieur).

Utilizzare la vite all'estremità posteriore della cerniera per regolare la posizione avanti-indietro del pannello della porta (assicurarsi che la parte anteriore del pannello della porta sia nello stesso piano dei pannelli superiore e inferiore).

Utilice el tornillo en el extremo trasero de la bisagra para ajustar la posición delantera y trasera del panel de la puerta (asegúrese de que la parte delantera del panel de la puerta esté en el mismo plano que los paneles superior e inferior).

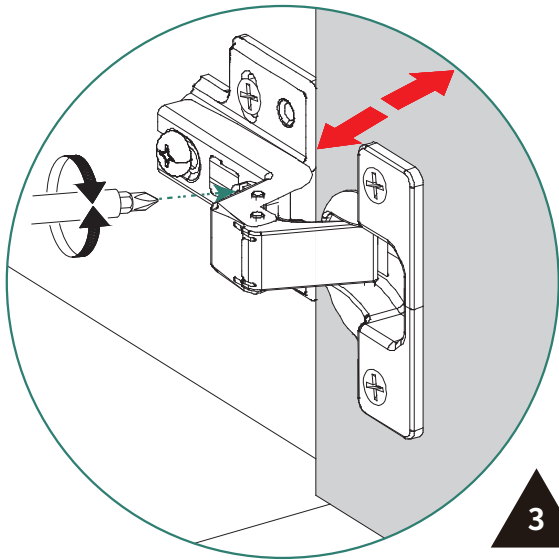

Use the screw at the front end of the hinge to adjust the left and right position of the door panel (ensure that the left and right sides of the door panel are in the same plane as the upper and lower panels).

Verwenden Sie die Schraube am vorderen Ende des Scharniers, um die links- und rechtsseitige Position des Türpanels zu justieren (stellen Sie sicher, dass die linke und rechte Seite des Türpanels in der gleichen Ebene wie die oberen und unteren Paneelen liegt).

Utilisez la vis à l'extrémité avant de la charnière pour régler la position gauche-droite du panneau de la porte (assurez-vous que les côtés gauche et droit du panneau de la porte sont dans le même plan que les panneaux supérieur et inférieur).

Utilizzare la vite all'estremità anteriore della cerniera per regolare la posizione sinistra-destra del pannello della porta (assicurarsi che i lati sinistro e destro del pannello della porta siano nello stesso piano dei pannelli superiore e inferiore).

Utilice el tornillo en el extremo frontal de la bisagra para ajustar la posición izquierda y derecha del panel de la puerta (asegúrese de que los lados izquierdo y derecho del panel de la puerta estén en el mismo plano que los paneles superior e inferior).

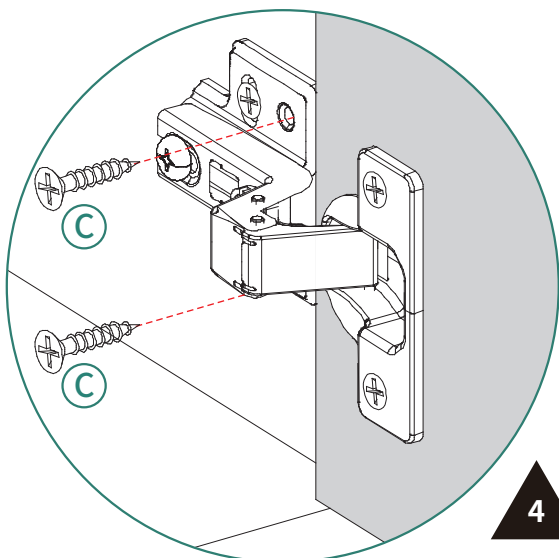
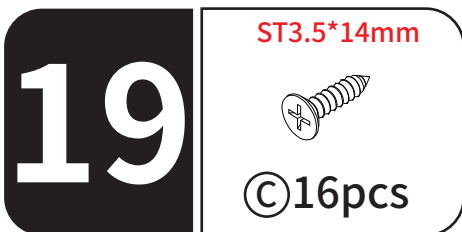

After completing these three steps, secure the other two screws on the hinge.

Nach Abschluss dieser drei Schritte sichern Sie die anderen beiden Schrauben am Scharnier fest.

Après avoir effectué ces trois étapes, fixez les deux autres vis sur la charnière.

Dopo aver completato questi tre passaggi, fissare le altre due viti sulla cerniera.

Después de completar estos tres pasos, asegure los otros dos tornillos en la bisagra.

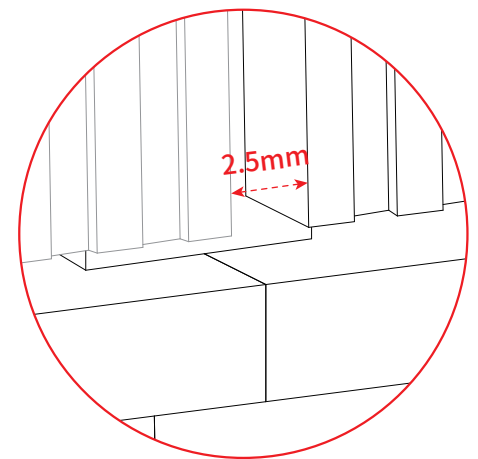
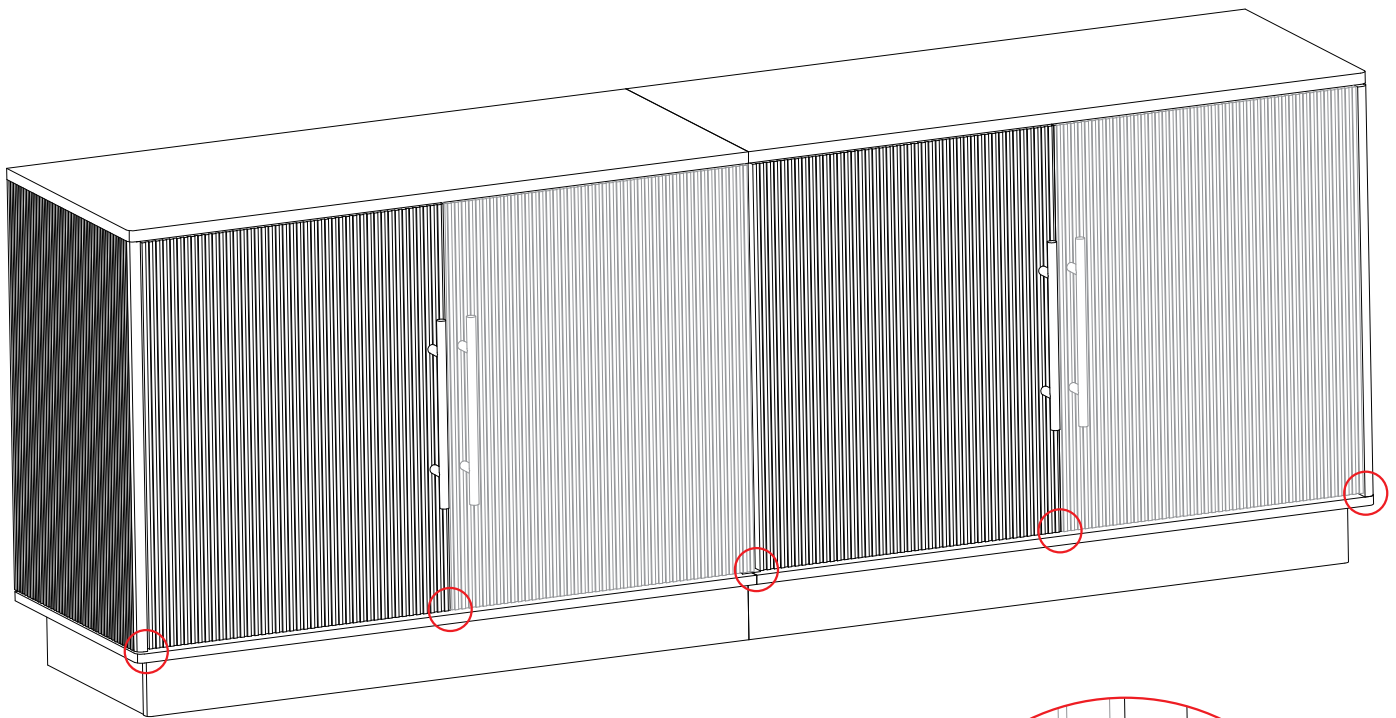

A door gap must be left at each position;
otherwise, the normal opening and closing of the door will be affected.

An jeder Position muss ein Türspalt gelassen werden,
sonst wird das normale Öffnen und Schließen der Tür beeinträchtigt.

Un jeu de porte doit être laissé à chaque emplacement ;
sinon, l'ouverture et la fermeture normales de la porte seront affectées.

È necessario lasciare un gioco di porta in ogni posizione;
altrimenti, verrà compromessa l'apertura e la chiusura normali della porta.

Se debe dejar un juego de puerta en cada posición;
de lo contrario, se verá afectada la apertura y cierre normales de la puerta.

20

ST4*30mm

I1 I3

I 2pcs

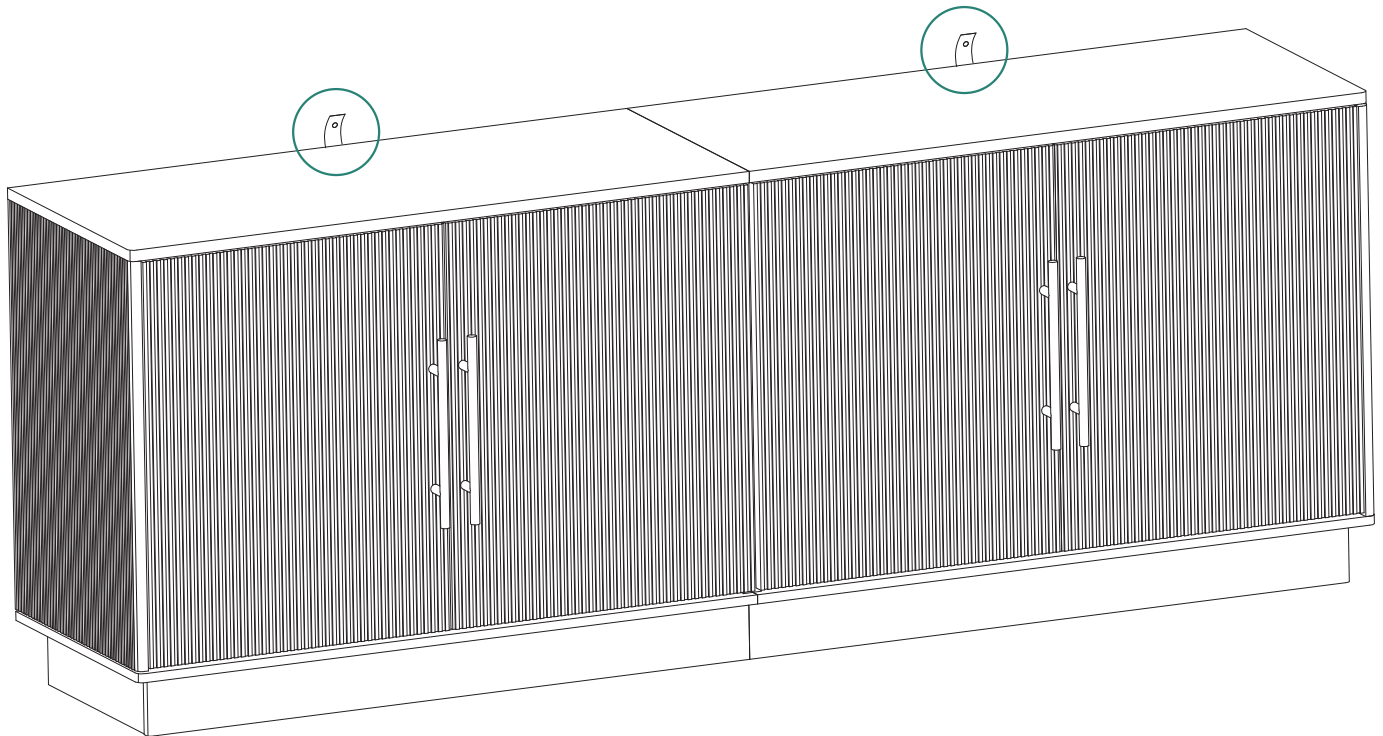
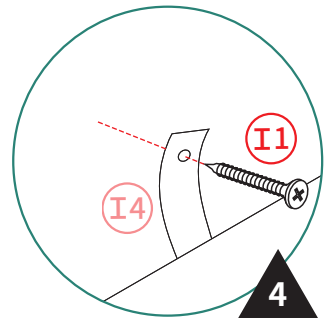
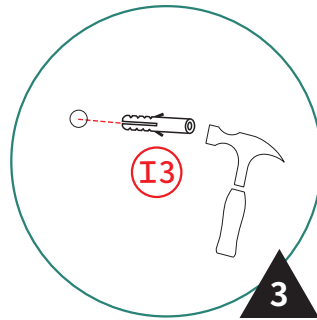
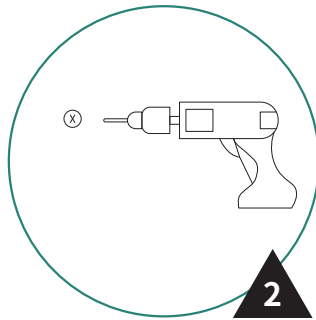
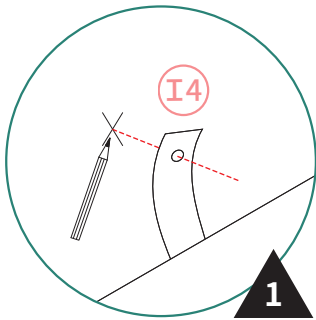

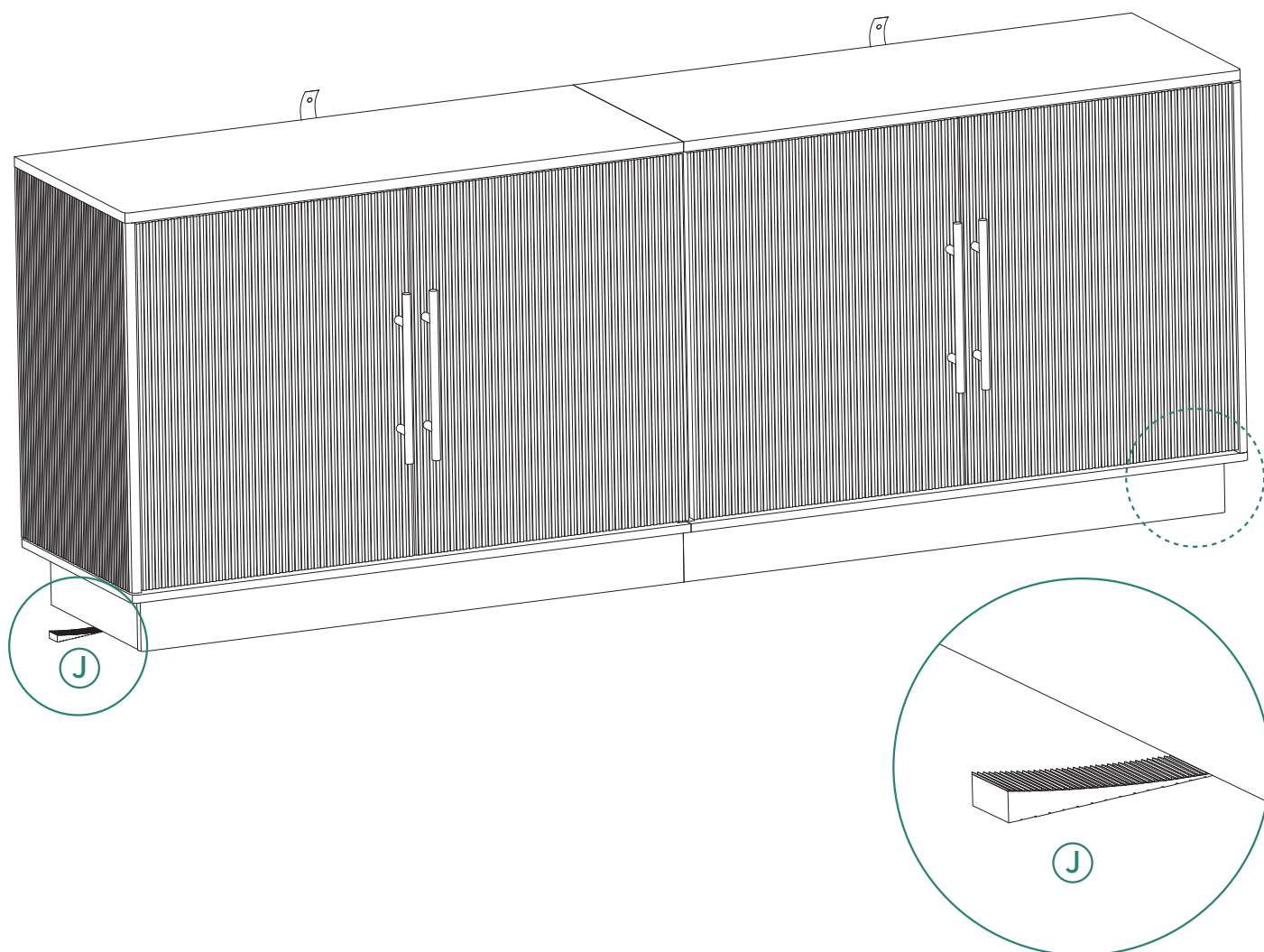
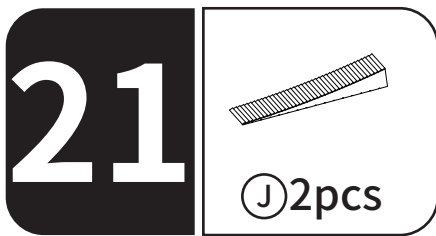

To prevent the product from shaking, insert accessory J into the bottom of the product.

Um ein Verrutschen des Produkts zu verhindern, stecken Sie das Zubehör J in den unteren Teil des Produkts.

Pour empêcher le produit de vibrer, insérez l'accessoire J dans le fond du produit.

Per evitare che il prodotto si agiti, inserisci l'accessorio J nella parte inferiore del prodotto.

Para evitar que el producto se mueva, inserta el accesorio J en la parte inferior del producto.

22

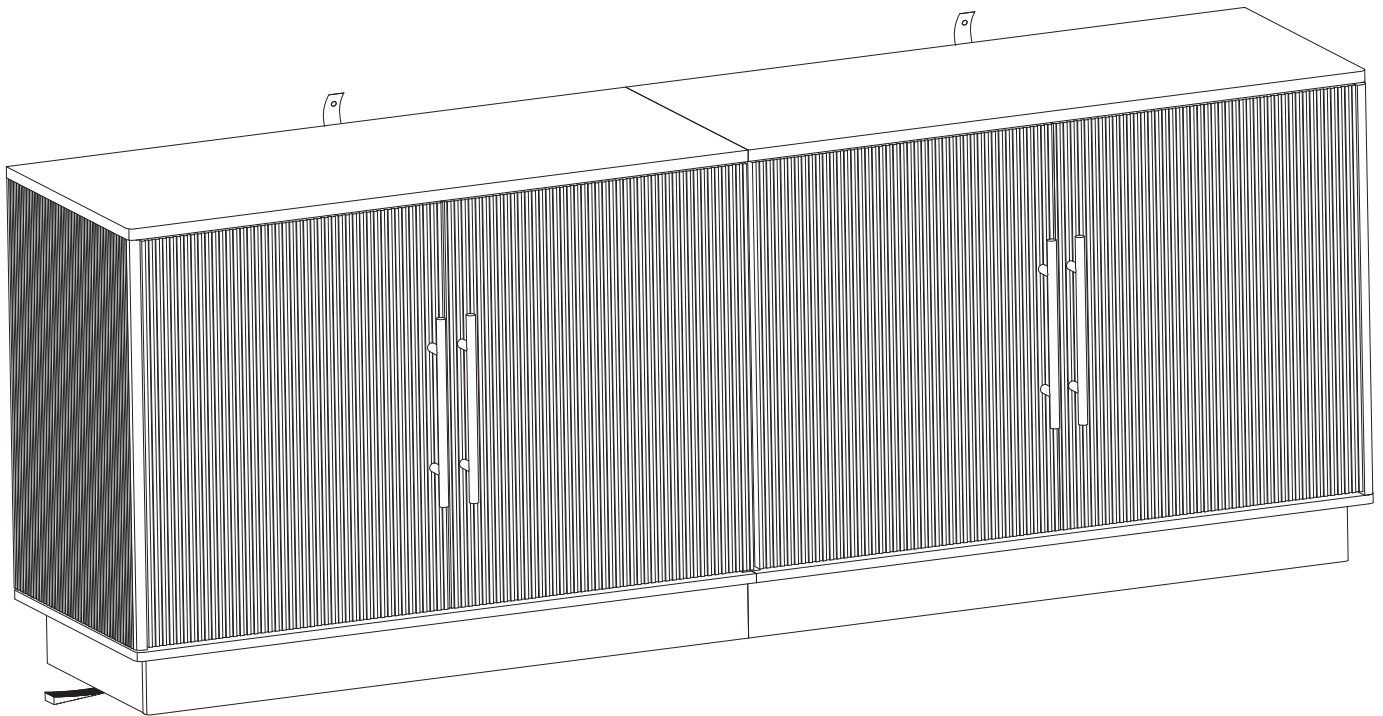

Installation Completed

Installation Abgeschlossen

Installation Complétée

Installazione Completata

Instalación Completada

HELP CENTER



Inquiry



Assembly issue



Missing parts

If you encounter any difficulties during assembly, please contact us.

Wenn Sie während der Montage auf Schwierigkeiten stoßen, kontaktieren Sie uns bitte.

Si vous rencontrez des difficultés lors du montage, veuillez nous contacter.

Se incontri difficoltà durante il montaggio, ti preghiamo di contattarci.

Si encuentras alguna dificultad durante el ensamblaje, por favor contáctanos.

DISCLAIMER

Manufacturer and seller expressly disclaim any and all liability for personal injury, property damage or loss, whether direct, indirect, or incidental, resulting from the incorrect attachment, improper use, inadequate maintenance, unapproved modification, or neglect of this product.

Der Hersteller und Verkäufer lehnen ausdrücklich jegliche Haftung für Personenschäden, Sachschäden oder Verluste ab, egal ob direkt, indirekt oder zufällig, die durch falsche Anbringung, unsachgemäßen Gebrauch, unzureichende Wartung, nicht genehmigte Änderungen oder Vernachlässigung dieses Produkts entstehen.

El fabricante y vendedor renuncian expresamente a toda responsabilidad por lesiones personales, daños materiales o pérdidas, ya sean directos, indirectos o incidentales, derivados de la incorrecta colocación, uso inadecuado, mantenimiento insuficiente, modificación no aprobada o negligencia de este producto.

Il produttore e il venditore declinano espressamente ogni responsabilità per lesioni personali, danni materiali o perdite, dirette, indirette o incidentali, derivanti dall'errato fissaggio, uso improprio, manutenzione inadeguata, modifica non autorizzata o negligenza di questo prodotto.

Le fabricant et le vendeur déclinent expressément toute responsabilité en cas de blessures corporelles, de dommages matériels ou de pertes, qu'ils soient directs, indirects ou accessoires, résultant de la fixation incorrecte, de l'utilisation inappropriée, de l'entretien insuffisant, de la modification non approuvée ou de la négligence de ce produit.