

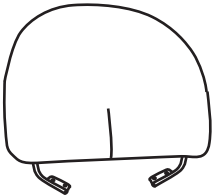







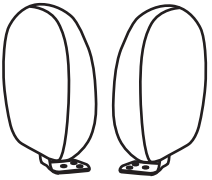
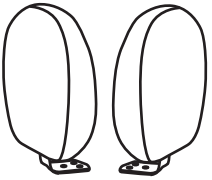
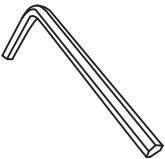

ASSEMBLY INSTRUCTIONS

| | |
|--|--|
| ①×1 | A×14  M6*22mm |
|  | B×6  |
| ②×1 | C×4  |
|  |  |
| ③×2 |  |
|  |  |
| ④×1 |  |
|  |  |

1

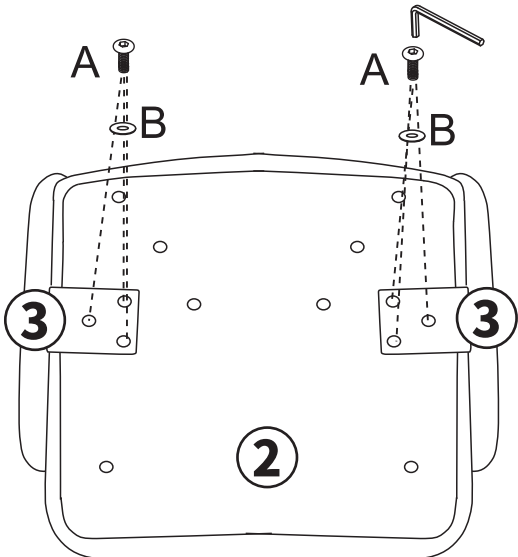

A **B** **3** **2** **3**

A×6

M6*22mm
B×6

Connect (2) and (3) by screwing (A) through (B).

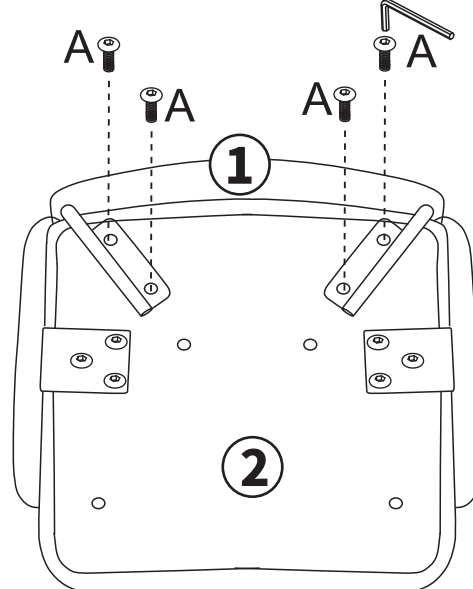
2



A **A** **1** **2** **A** **A**

A×4

M6*22mm

Screw (A) to connect (1) and (2).

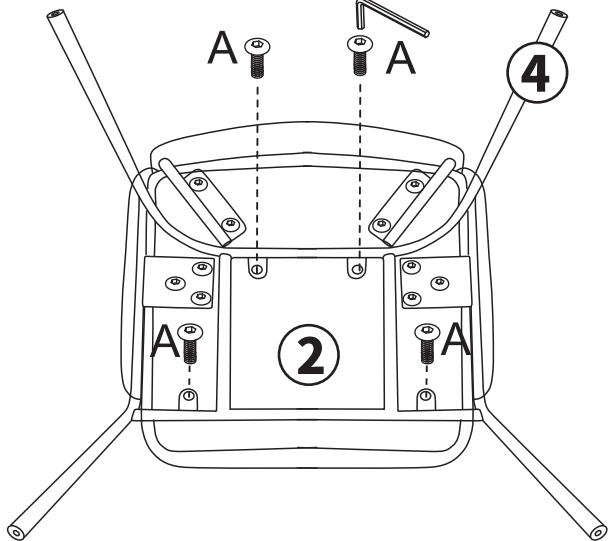
3



A **A** **4** **2** **A** **A**

A×4

M6*22mm

Screw (A) to connect (4) and (2).

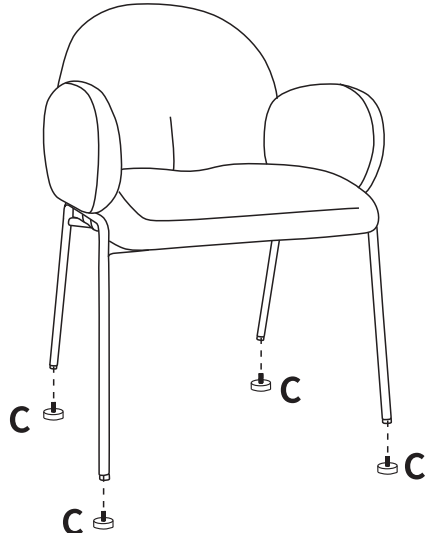
4



C **C** **C** **C**

C×4

If you feel that the chair is leaning to one side due to uneven ground, rotate the foot pads (C) to adjust it.

If there are any questions during the assembly process, please contact us at AssemblyMaster@hotmail.com. An video and description about the step you were stuck will help us to understand the problem quickly.