

ASSEMBLY INSTRUCTIONS / INSTRUCTIONS DE MONTAGE

FULL HOUSE BED / LIT COMPLET

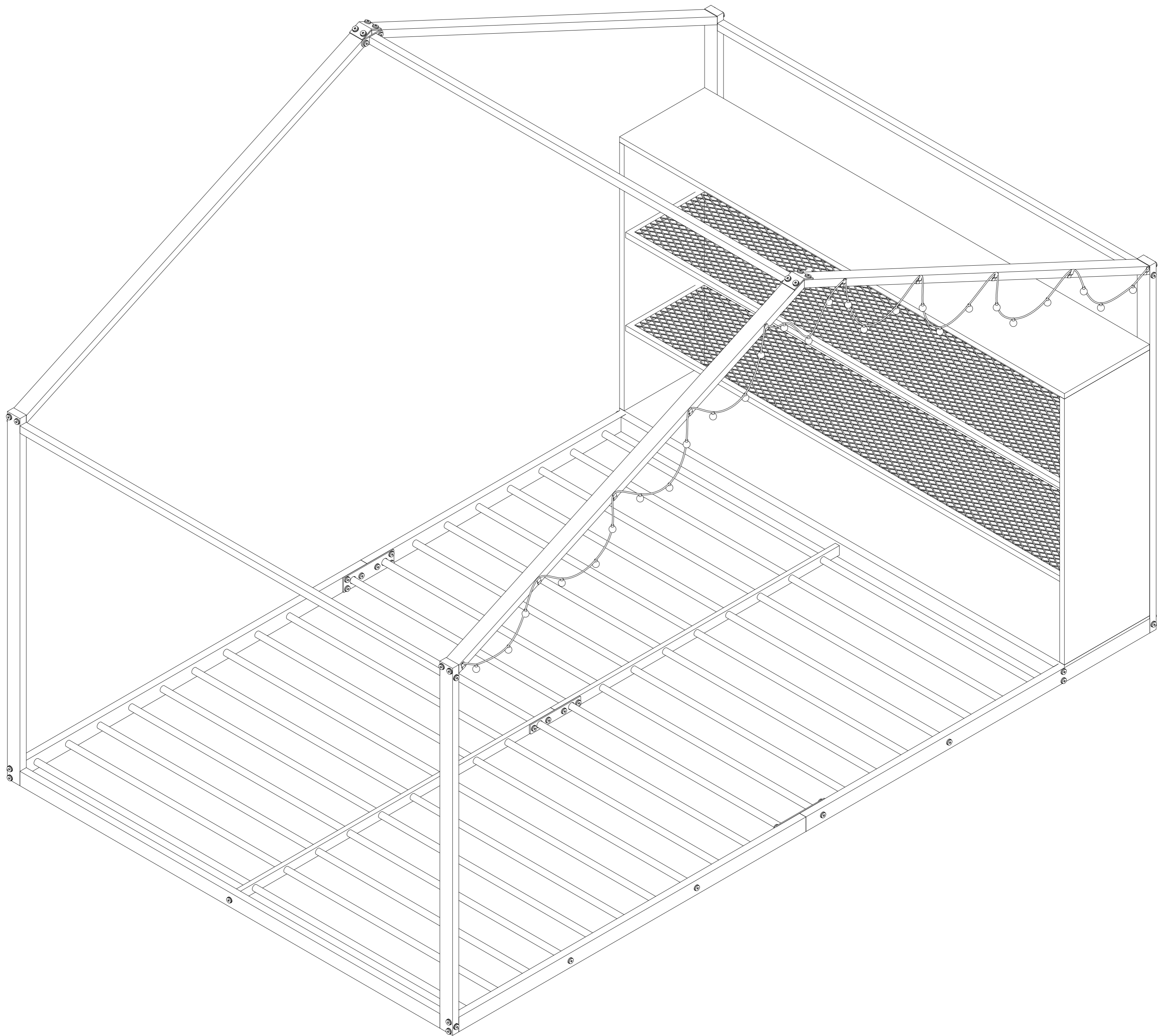

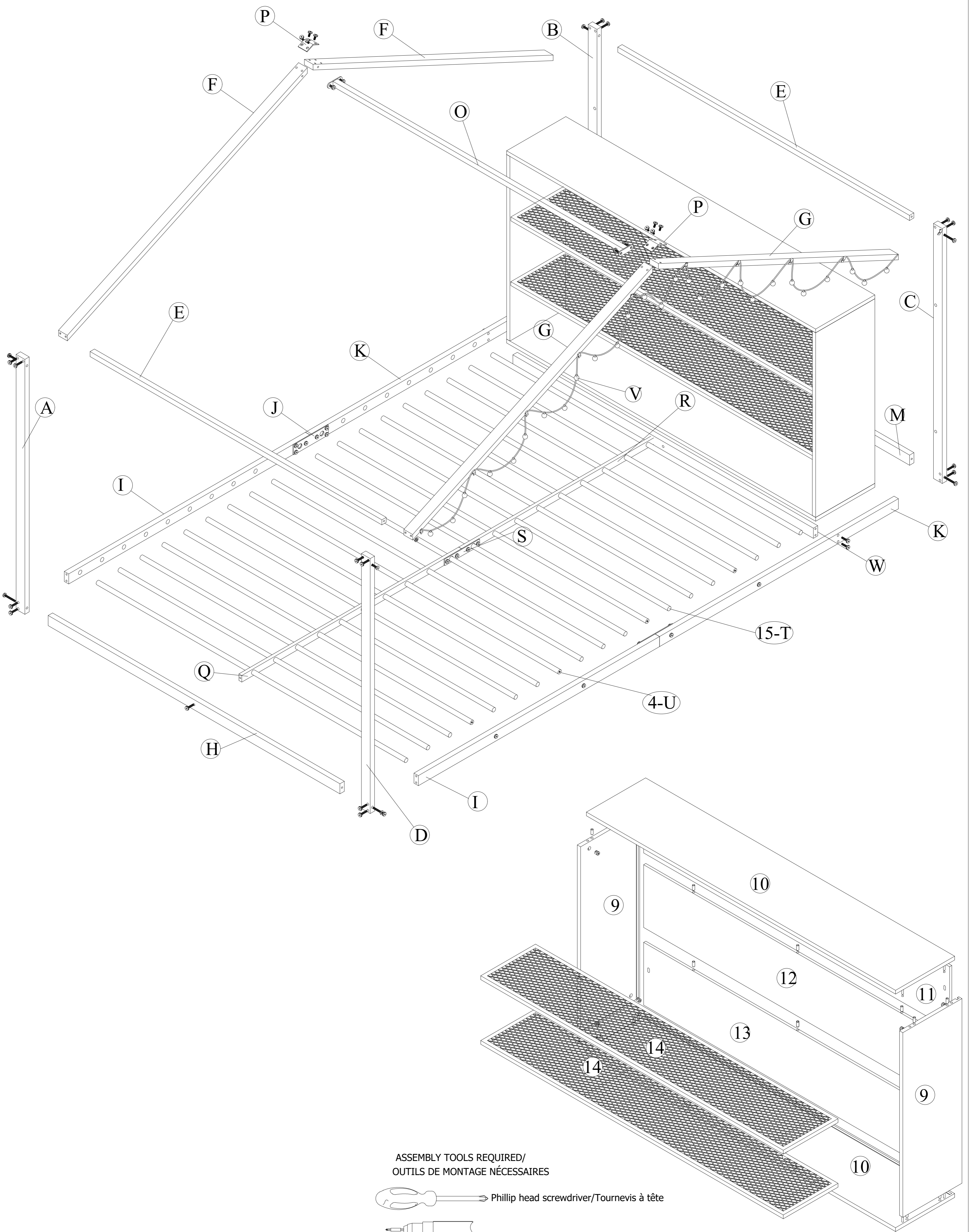



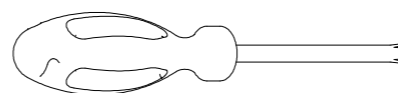

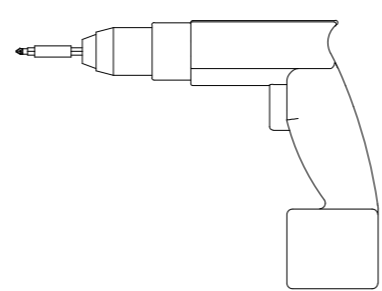

ASSEMBLY TOOLS REQUIRED/
OUTILS DE MONTAGE NÉCESSAIRES

 Phillip head screwdriver/Tournevis à tête

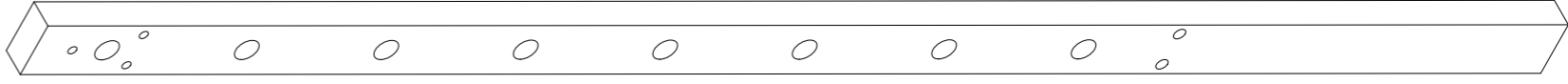
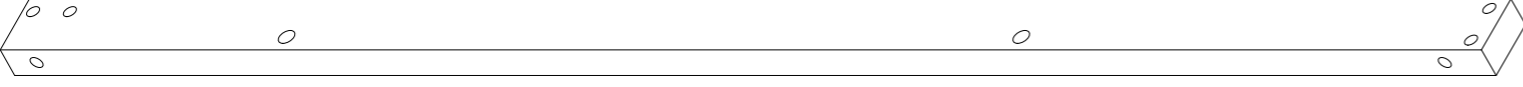
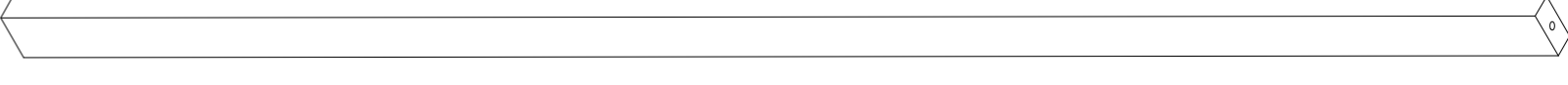
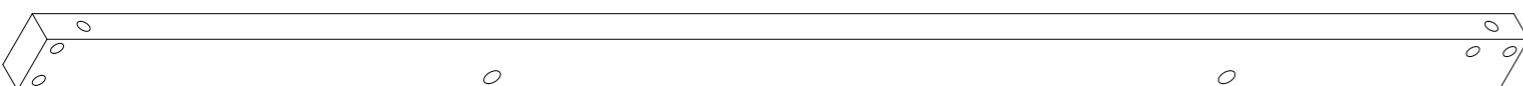
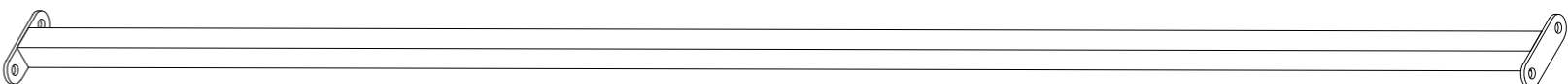

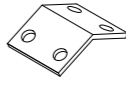
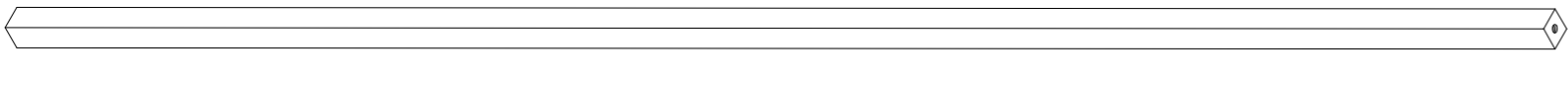
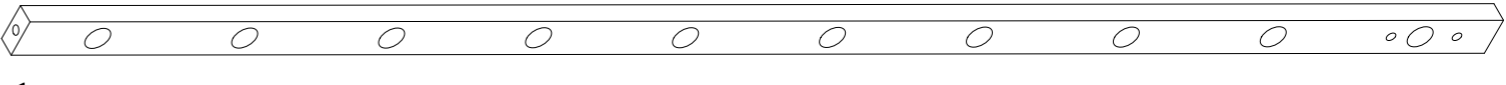
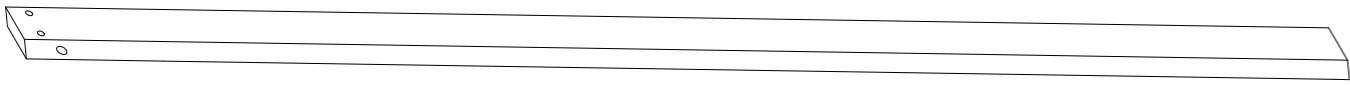
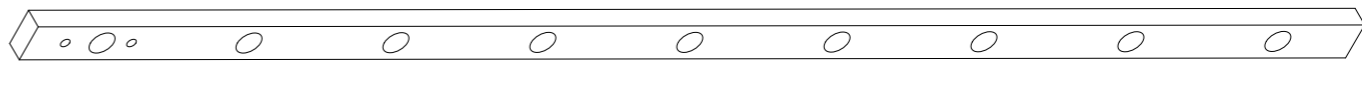
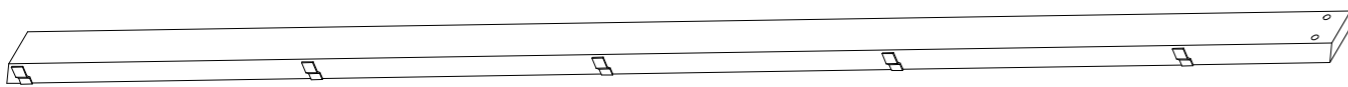
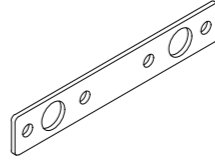
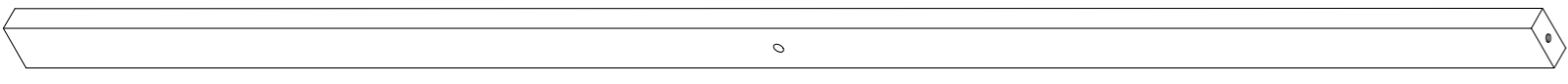
Power tools assemble this product/
Les outils électriques assemblent ce produit

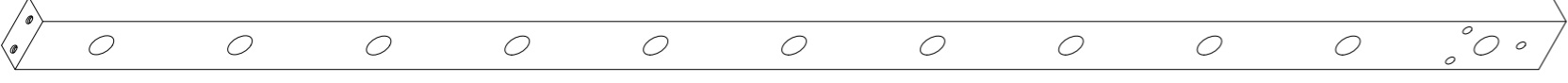
PARTS LIST/LISTE DES PIECES

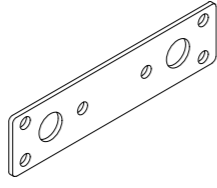
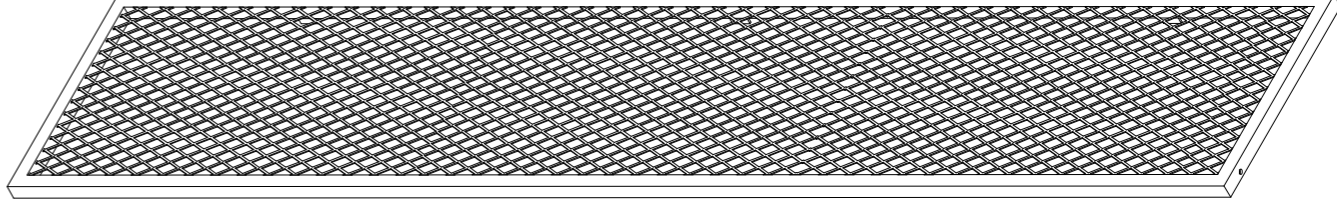
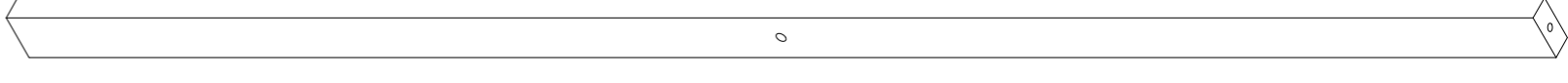
| | |
|---|--|
| <p>A</p>  <p>Qty: 1 pcs</p> | <p>K</p>  <p>Qty: 2 pcs</p> |
| <p>B</p>  <p>Qty: 1 pcs</p> | <p>M</p>  <p>Qty: 1 pcs</p> |
| <p>C</p>  <p>Qty: 1 pcs</p> | <p>O</p>  <p>Qty: 1 pcs</p> |
| <p>D</p>  <p>Qty: 1 pcs</p> | <p>P</p>  <p>Qty: 2 pcs</p> |
| <p>E</p>  <p>Qty: 2 pcs</p> | <p>Q</p>  <p>Qty: 1 pcs</p> |
| <p>F</p>  <p>Qty: 2 pcs</p> | <p>R</p>  <p>Qty: 1 pcs</p> |
| <p>G</p>  <p>Qty: 2 pcs</p> | <p>S</p>  <p>Qty: 1 pcs</p> |
| <p>H</p>  <p>Qty: 1 pcs</p> | <p>T</p>  <p>Qty: 15 pcs</p> |
| <p>I</p>  <p>Qty: 2 pcs</p> | <p>U</p>  <p>Qty: 4 pcs</p> |
| <p>J</p>  <p>Qty: 2 pcs</p> | <p>V</p>  <p>Qty: 2 pcs</p> |
| <p>W</p>  <p>Qty: 1 pcs</p> | |

PARTS LIST/LISTE DES PIECES

9 Wood panels / panneaux de bois

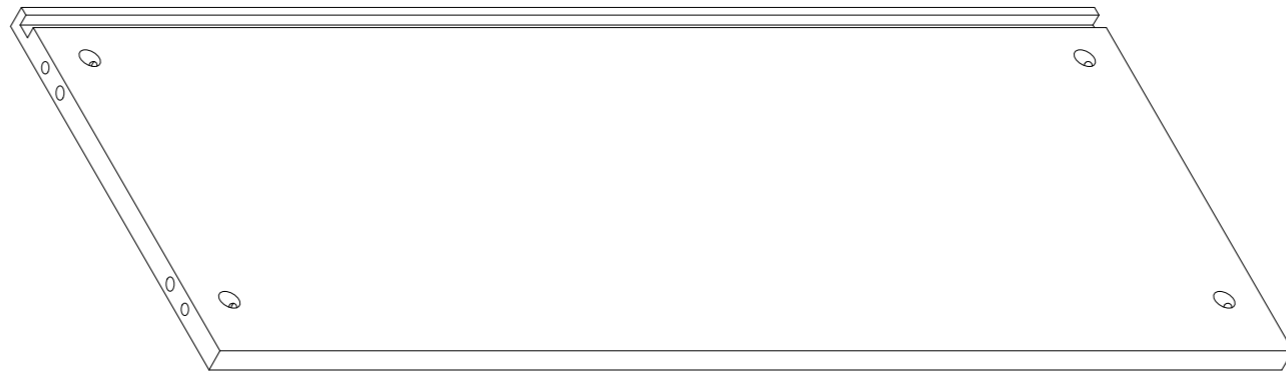

Qty: 2 pcs

10 Wood panels / panneaux de bois

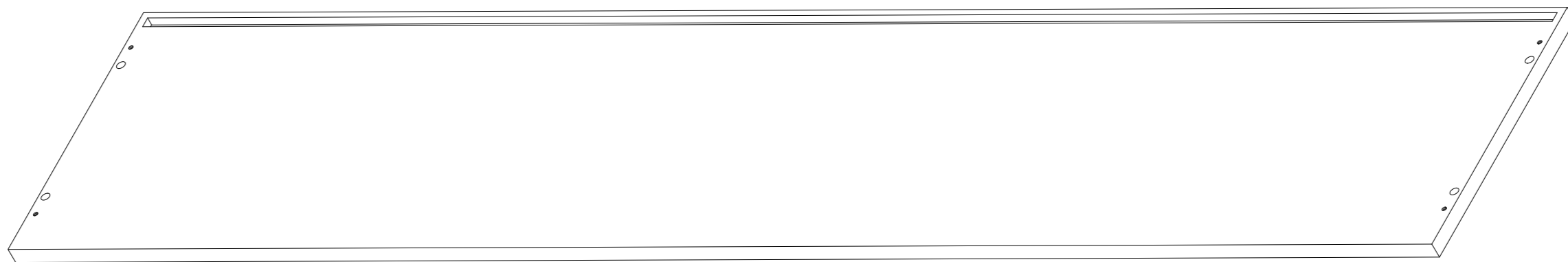

Qty: 2 pcs

11 Wood panels / panneaux de bois

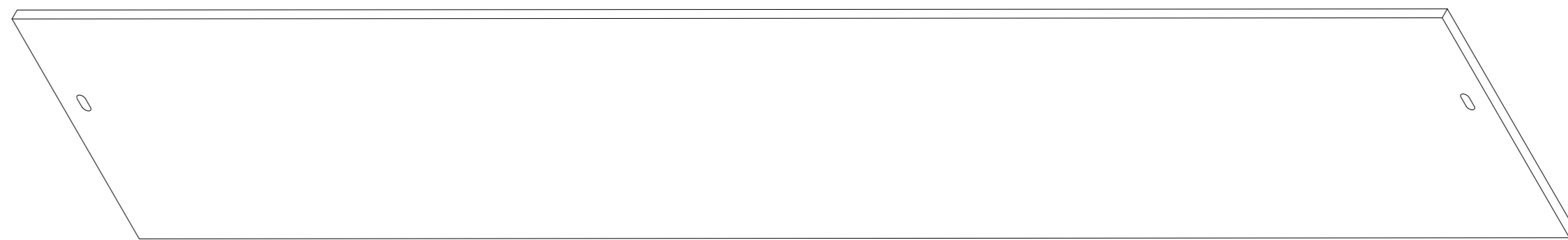

Qty: 1 pcs

12 Wood panels / panneaux de bois

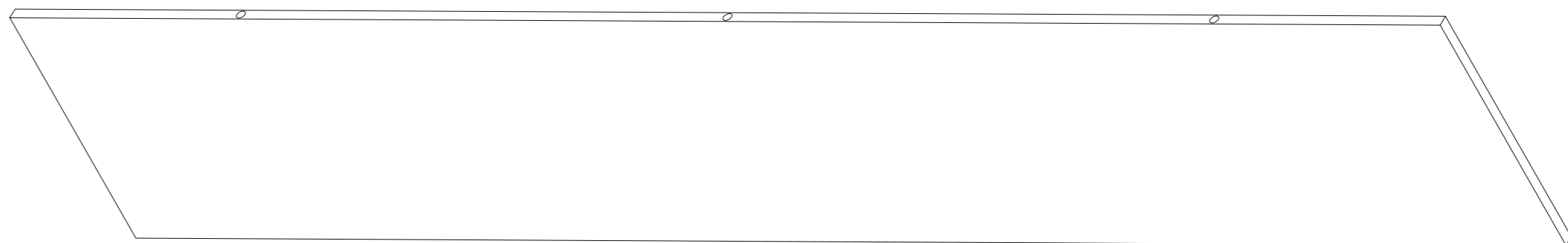

Qty: 1 pcs

13 Wood panels / panneaux de bois

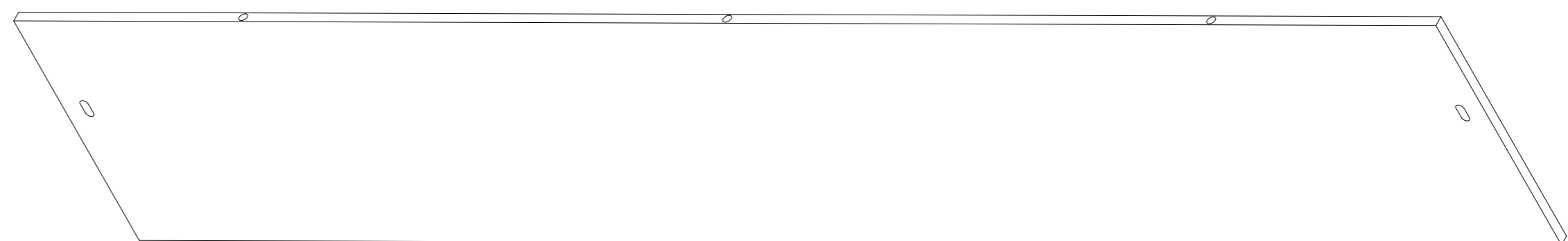

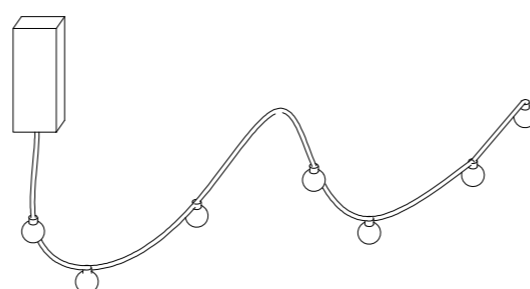

Qty: 1 pcs

14 Led Light

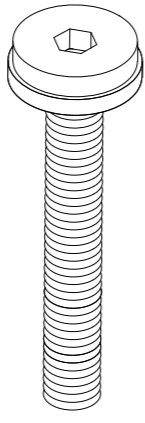
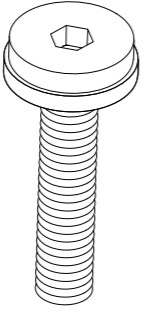
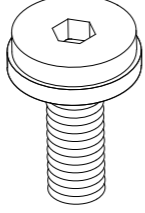
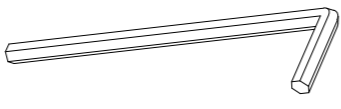
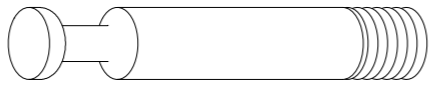

Qty: 1 pcs

Hardware List/ Liste du matériel

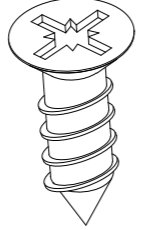
| | | | |
|------|---|---|-----|
| I |  | 1/4 x50 | x8 |
| II |  | 1/4 x30 | x26 |
| III |  | 1/4 x15 | x36 |
| IV |  | 4 x48 | x1 |
| V |  | Cam latch 1 | x8 |
| VI |  | Cam latch 2 | x8 |
| VII |  | Positioning pin Ø8 Goupille de positionnement Ø8 | x8 |
| VIII |  | Positioning pin Ø6 Goupille de positionnement Ø6 | x6 |
| IX |  | Wood screw L12 Vis à bois L12 | x10 |

STEP 1 / ÉTAPE 1

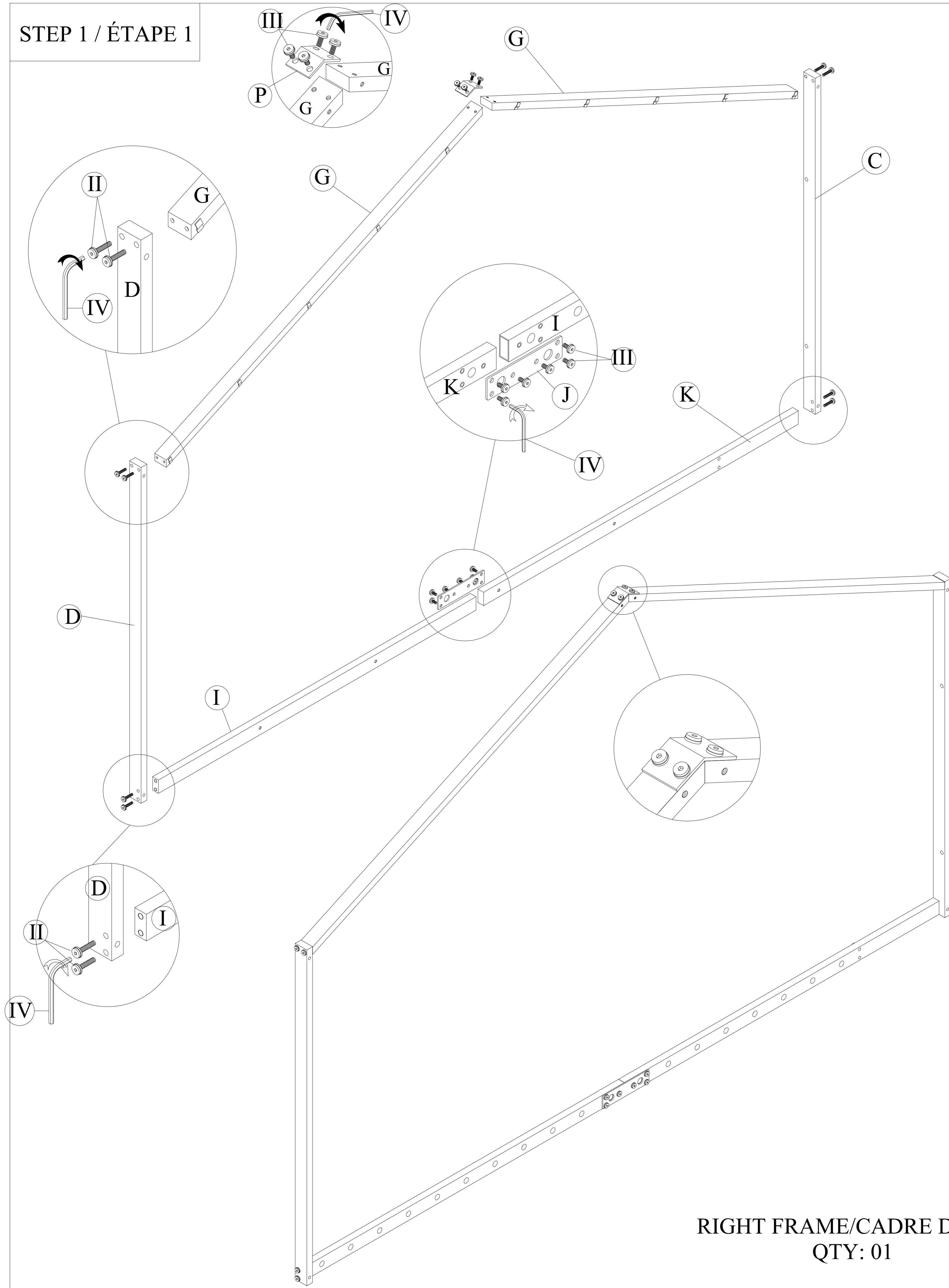

RIGHT FRAME/CADRE DROIT
QTY: 01

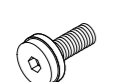
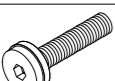
| Hardware/Matériel | | |
|-------------------|---|---------|
| Code | Image | Qty/Qte |
| III |  | 10 pcs |
| II |  | 8 pcs |

STEP 2 / ÉTAPE 2

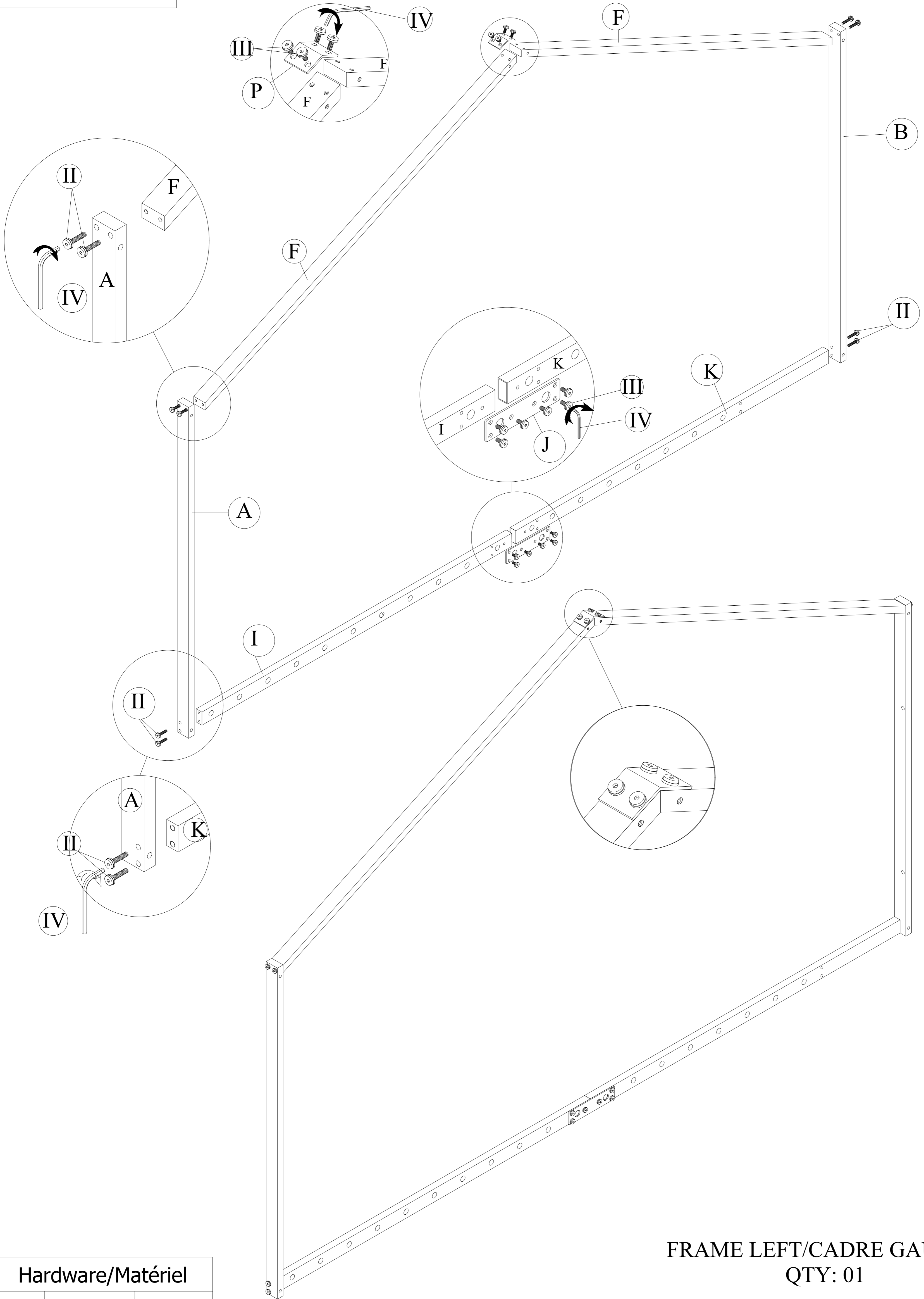

FRAME LEFT/CADRE GAUCHE
QTY: 01

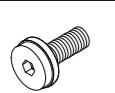
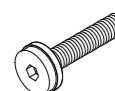
| Hardware/Matériel | | |
|-------------------|---|---------|
| Code | Image | Qty/Qte |
| III |  | 10 pcs |
| II |  | 8 pcs |

STEP 3 / ÉTAPE 3

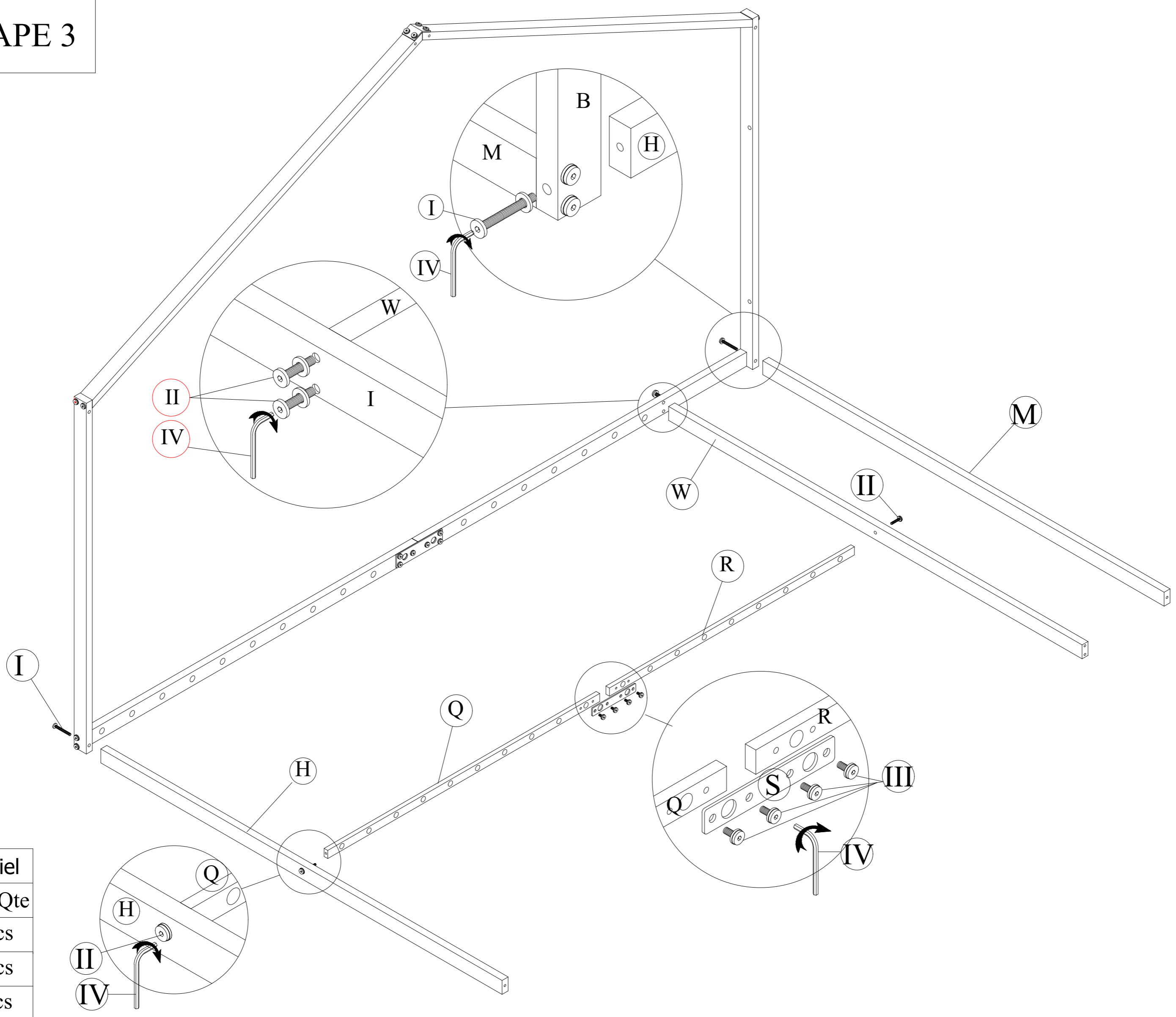

| Hardware/Matériel | | |
|-------------------|-------|---------|
| Code | Image | Qty/Qte |
| III | | 4 pcs |
| II | | 4 pcs |
| I | | 2 pcs |

STEP 4 / ÉTAPE 4

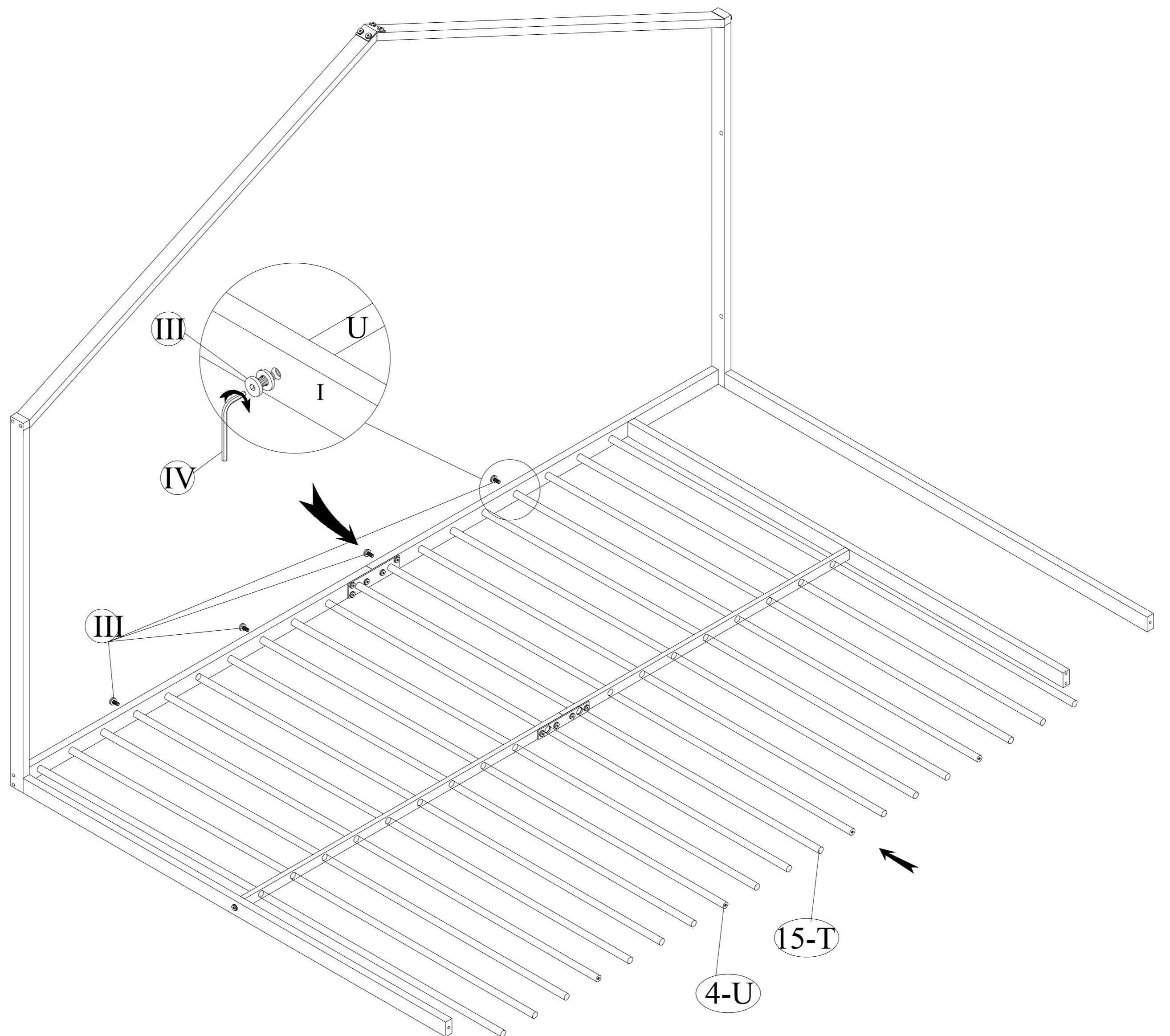

| Hardware/Matériel | | |
|-------------------|-------|---------|
| Code | Image | Qty/Qte |
| III | | 4 pcs |

STEP 5 / ÉTAPE 5

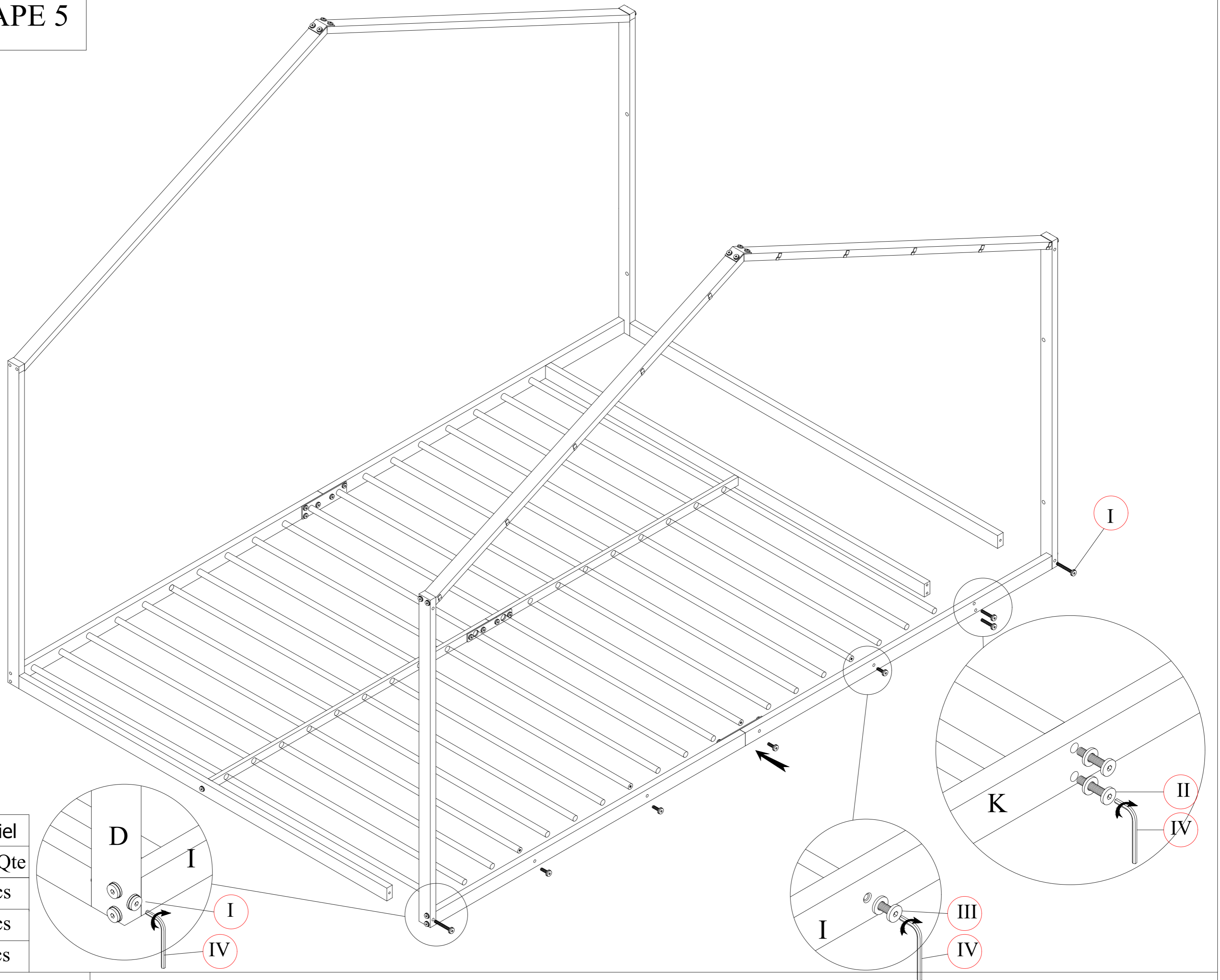

| Hardware/Matériel | | |
|-------------------|-------|---------|
| Code | Image | Qty/Qte |
| III | | 4 pcs |
| II | | 2 pcs |
| I | | 2 pcs |

STEP 6 / ÉTAPE 6

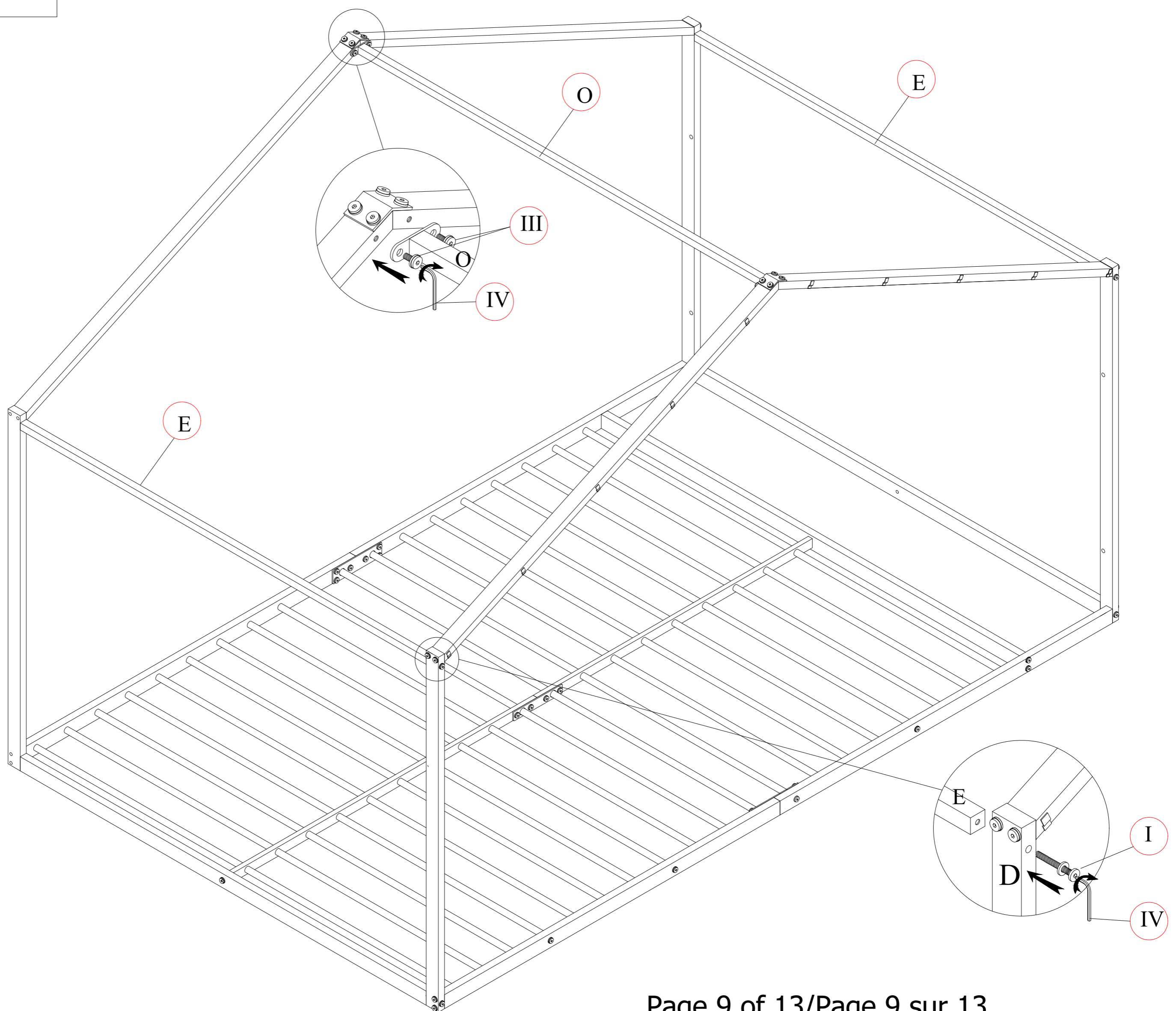

| Hardware/Matériel | | |
|-------------------|-------|---------|
| Code | Image | Qty/Qte |
| III | | 4 pcs |
| I | | 4 pcs |

STEP 7 / ÉTAPE 7

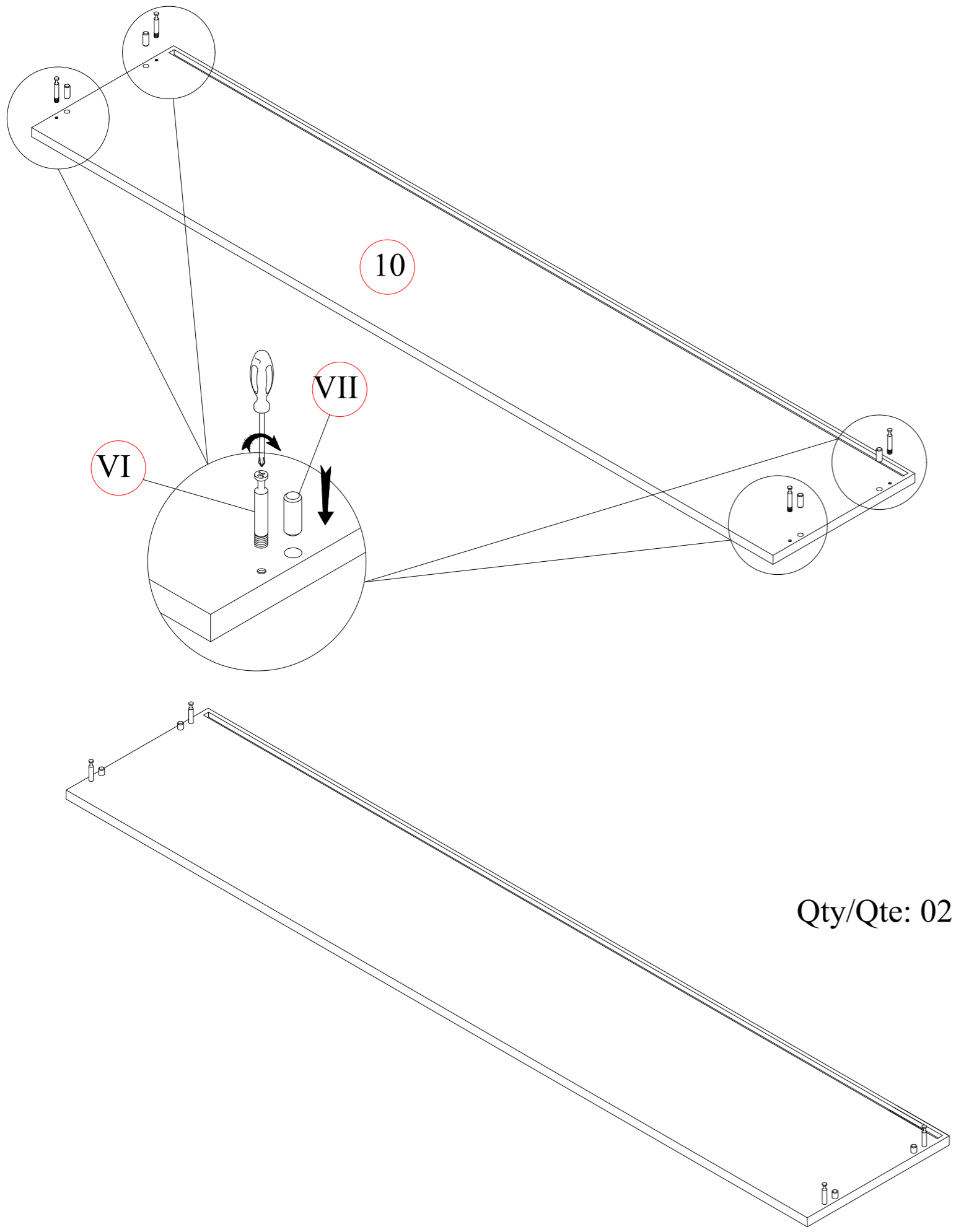

| Hardware/Matériel | | |
|-------------------|-------|---------|
| Code | Image | Qty/Qte |
| VII | | 8 pcs |
| VI | | 8 pcs |

STEP 8 / ÉTAPE 8

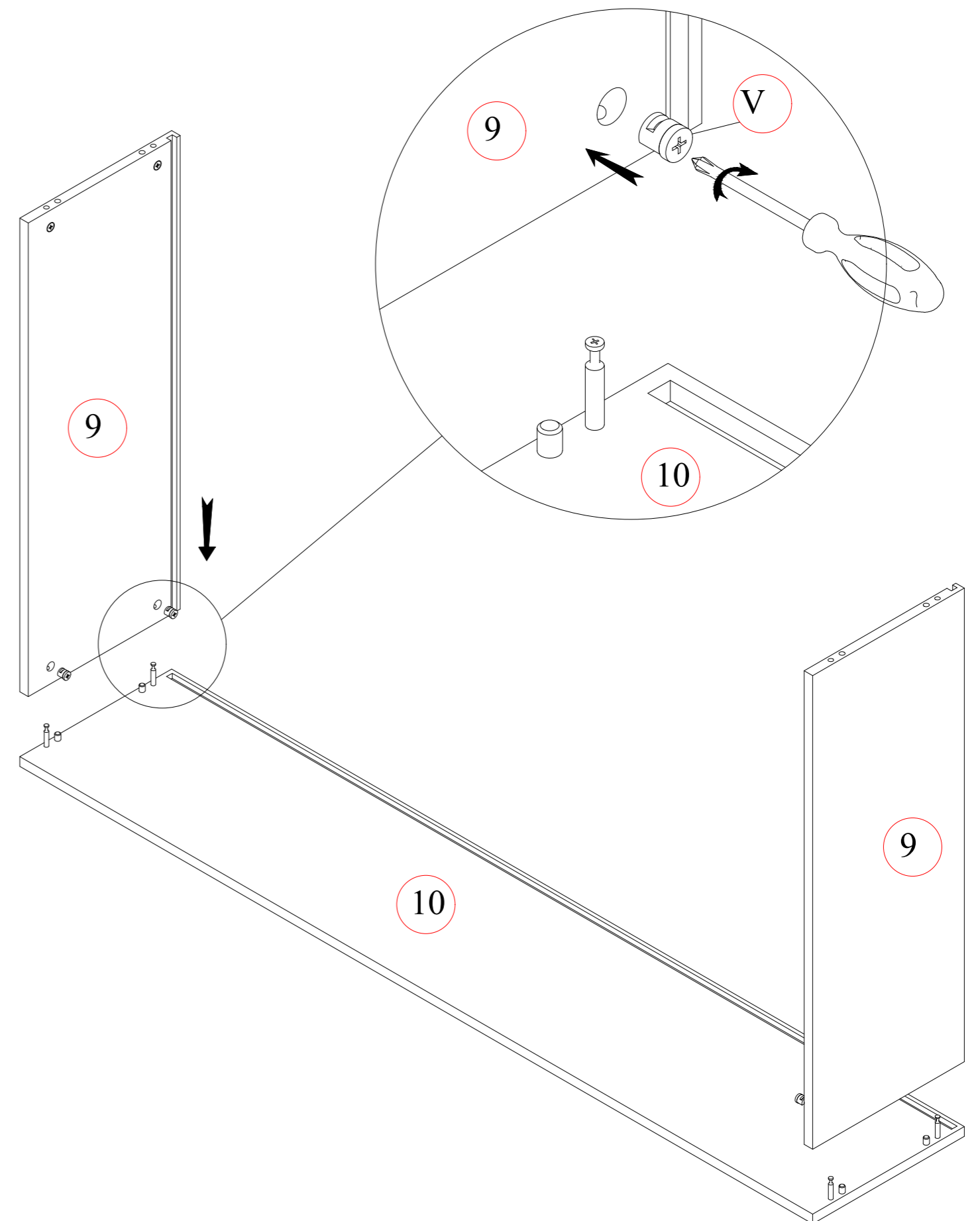

| Hardware/Matériel | | |
|-------------------|-------|---------|
| Code | Image | Qty/Qte |
| V | | 4 pcs |

STEP 9 / ÉTAPE 9

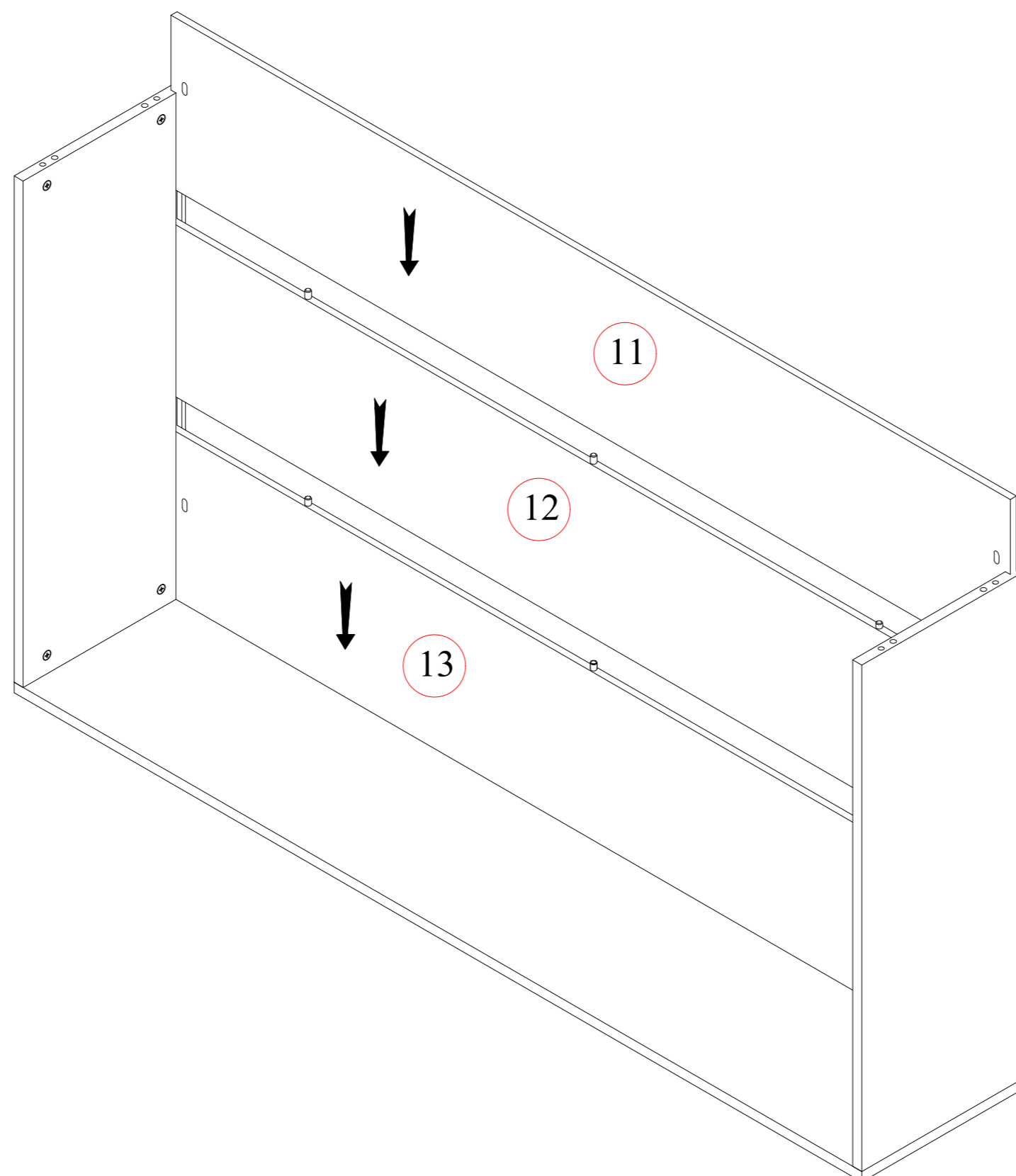

| Hardware/Matériel | | |
|-------------------|-------|---------|
| Code | Image | Qty/Qte |
| VIII | | 6 pcs |

STEP 10 / ÉTAPE 10

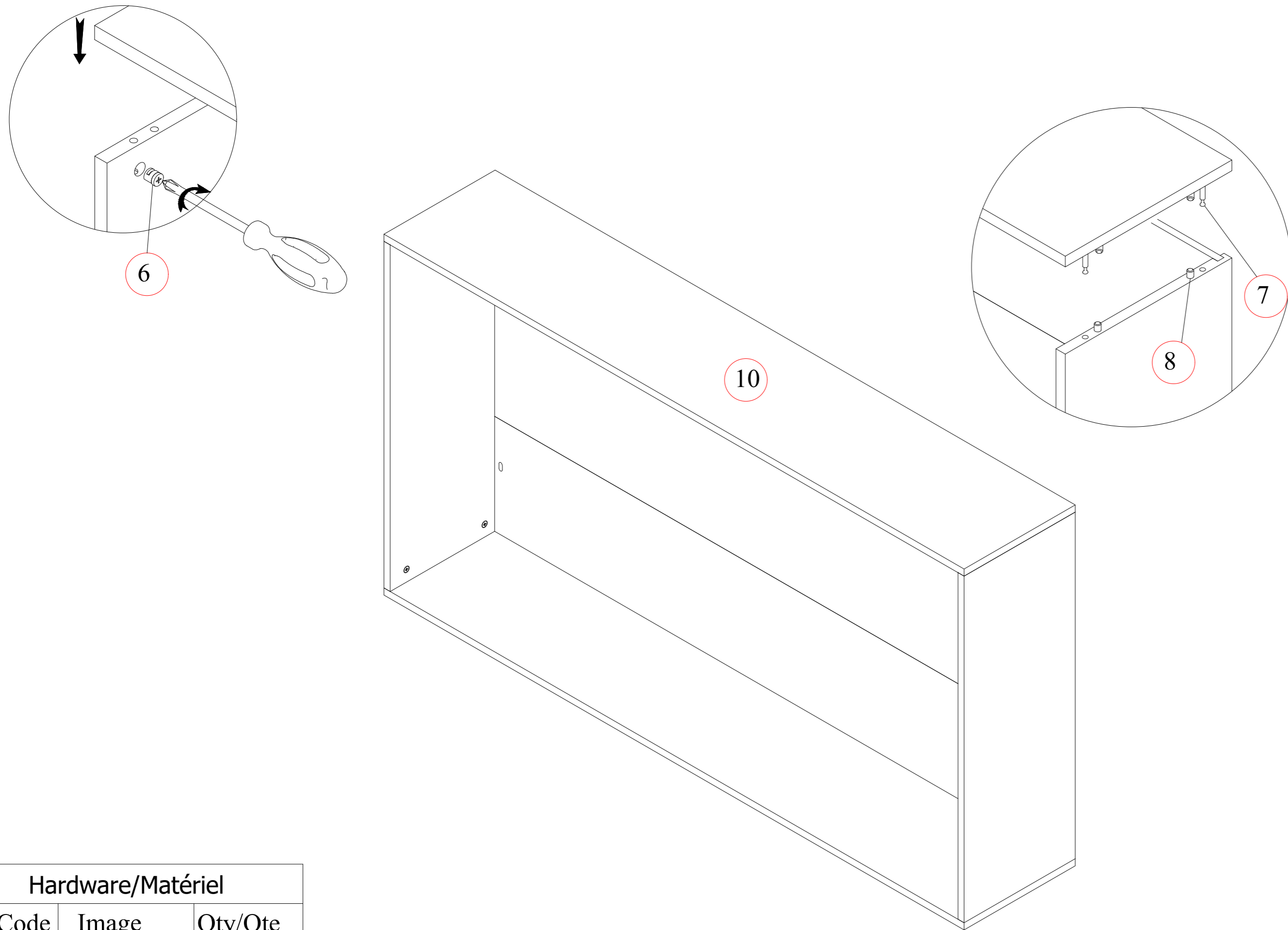

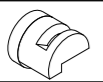
| Hardware/Matériel | | |
|-------------------|---|---------|
| Code | Image | Qty/Qte |
| V |  | 4 pcs |

STEP 11 / ÉTAPE 11

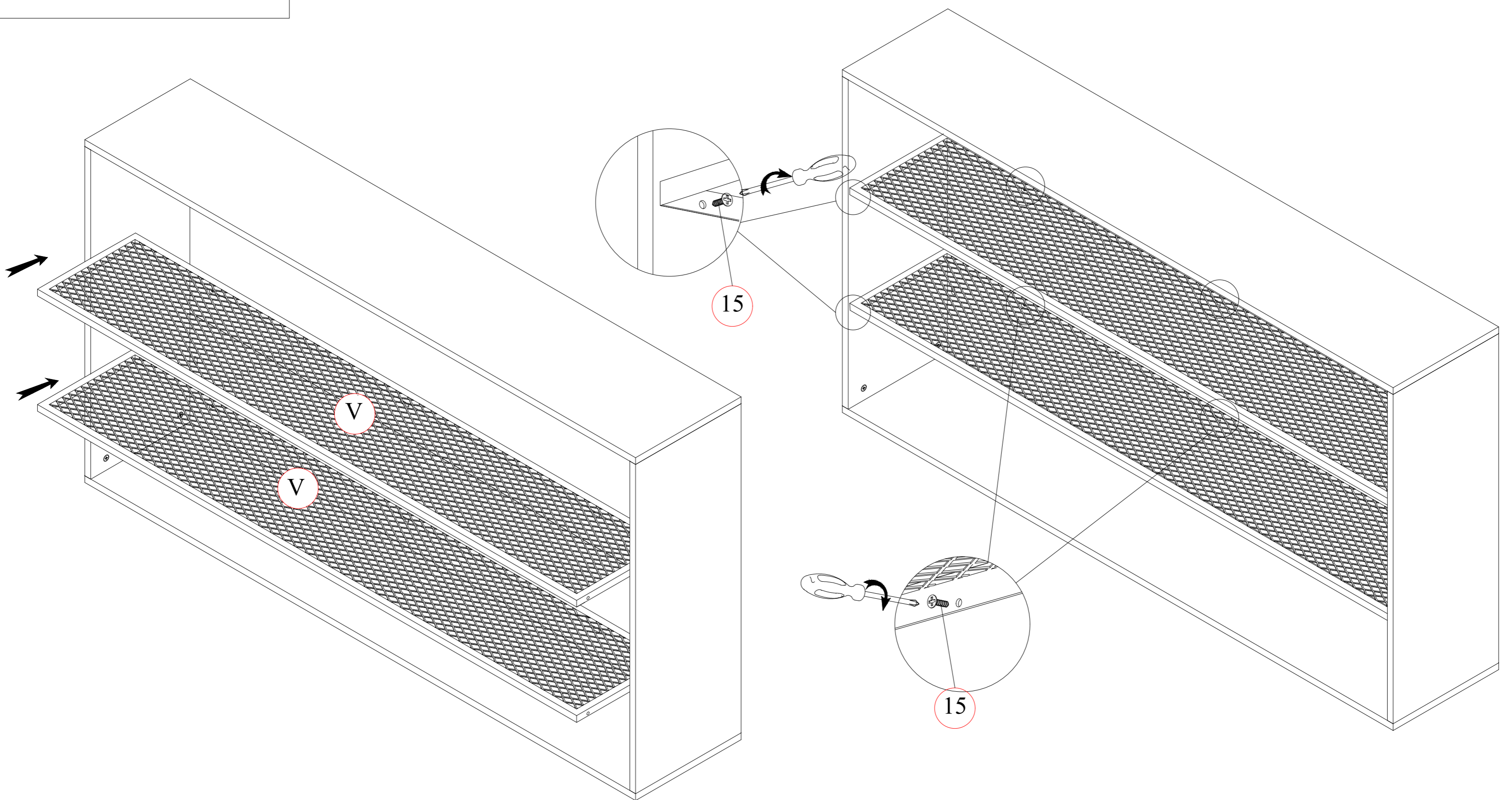

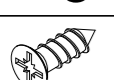
| Hardware/Matériel | | |
|-------------------|---|---------|
| Code | Image | Qty/Qte |
| IX |  | 10 pcs |

STEP 11 / ÉTAPE 11

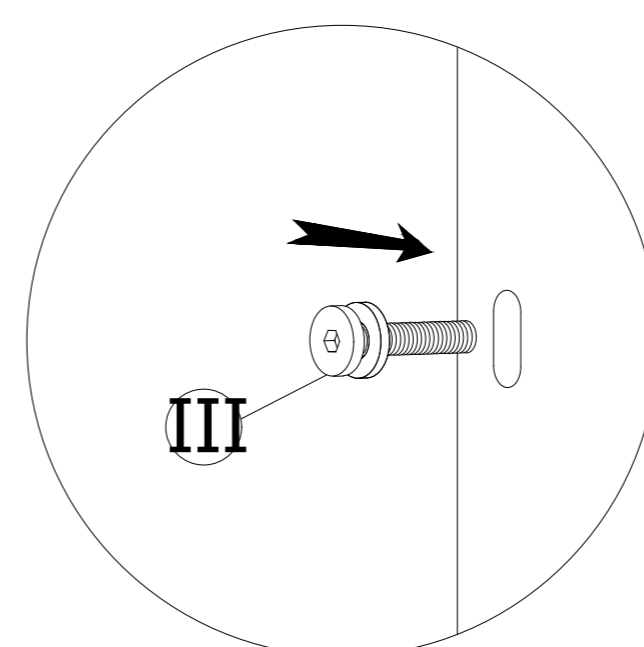
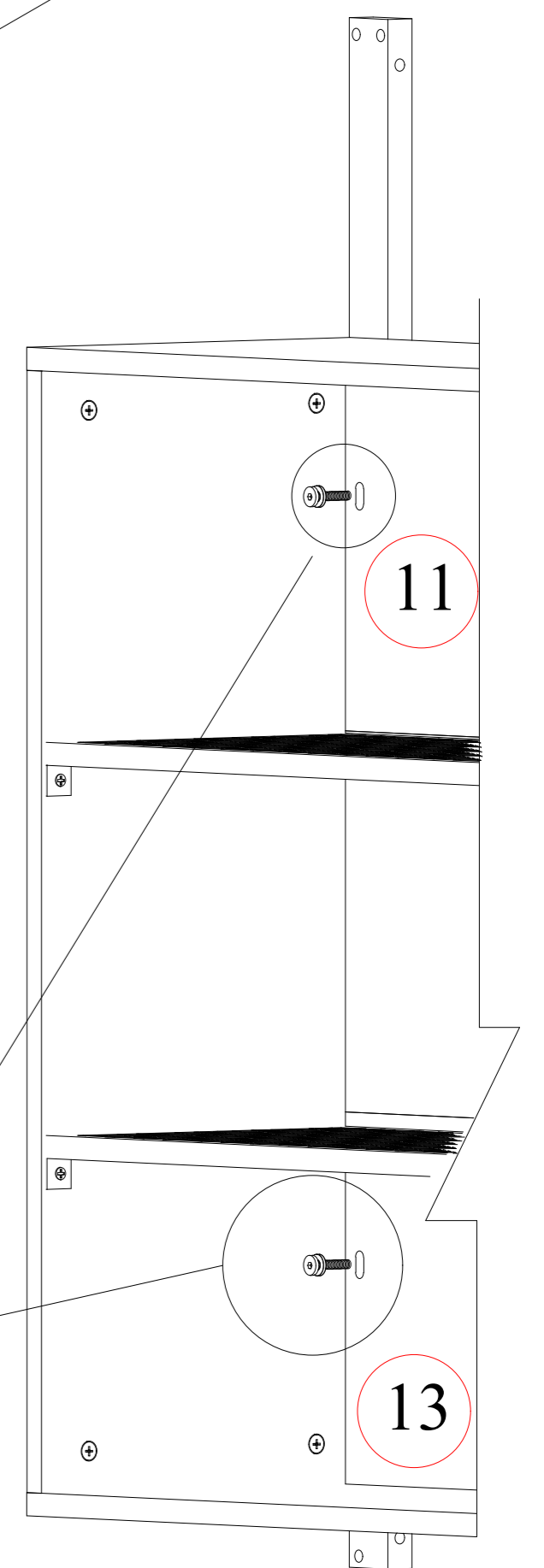
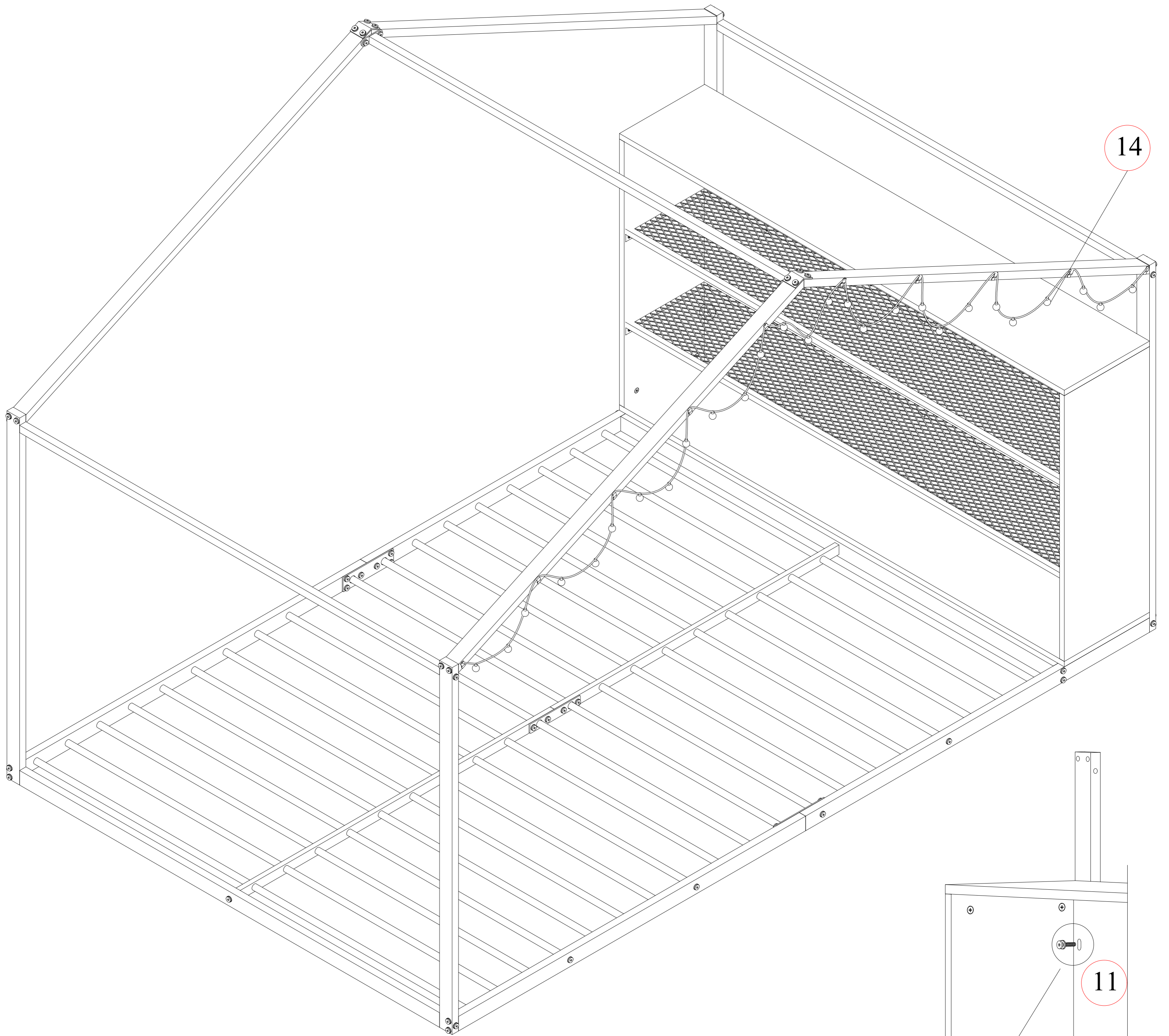

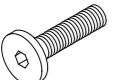
| Hardware/Matériel | | |
|-------------------|---|---------|
| Code | Image | Qty/Qte |
| 2 |  | 4 pcs |

FULL HOUSE BED / LIT COMPLET

