

INSTALLATION

Product Manual
Description du produit

Version: 020527CA-01-25A-AA



IMPORTANT INFORMATION!

please read the entire manual before starting to assemble and/or using this product. follow the manual thoroughly and keep it for further reference.



AVOID SCRATCHES!

In order to avoid scratching this furniture should be assembled on a soft layer- could be a rug.



IMPROVE EFFICIENCY !

Try to find a partner to install with you, which can speed up the installation efficiency and shorten the time.



ANTI-TOPPLE WARNING !

Overturnd furniture can cause serious or fatal crush injuries. To prevent tipping over, be sure to use the wall attachment, if not included with this product. Please purchase the wall attachment that fit your wall. If unsure, seek professional advice. Please read and follow each step of the instructions carefully.

IMPORTANT !

It is important that any product which is assembled using any kind of screw is re-tightened 2 weeks after assembly, and once every 3 months - in order to assure stability through-out the lifespan of the product.

For regular maintenance and cleaning of the product, for the frame, please use a rag dipped in neutral detergent to fully wipe it, and then dry it with a clean rag. For glass materials, wipe with a rag dampened with water glass cleaner, and then dry with a dry rag.

Do not use an electric screwdriver, and do not use too much force when installing, because the board is easy to break.

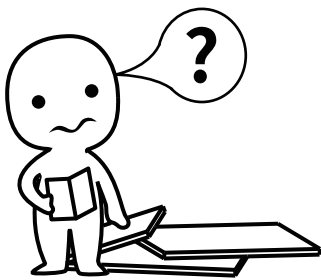

AVERTISSEMENT!

Veillez lire le manuel en entier avant de commencer à assembler et/ou à utiliser ce produit. Suivez attentivement le manuel et conservez-le pour référence ultérieure.

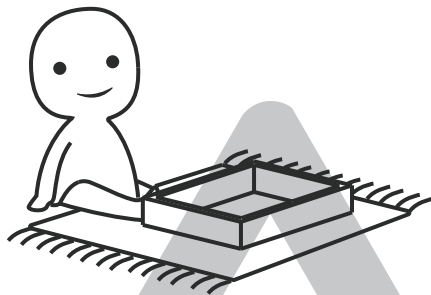
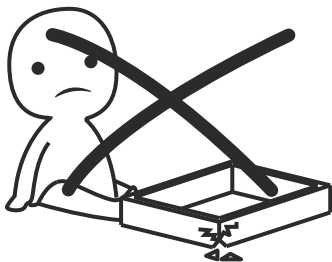

ÉVITEZ LES RAYURES !

Afin d'éviter de rayer ce meuble doit être assemblé sur une couche souple - pourrait être un tapis.

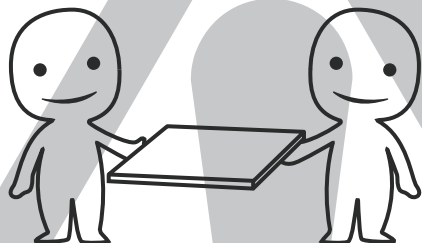

OPTIMISEZ L'EFFICACITÉ !

Essayez de trouver un partenaire à installer avec vous, ce qui peut accélérer l'efficacité de l'installation et raccourcir le temps.

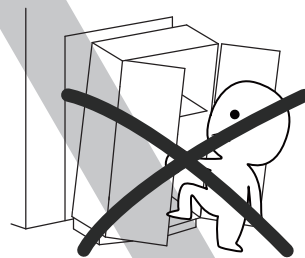
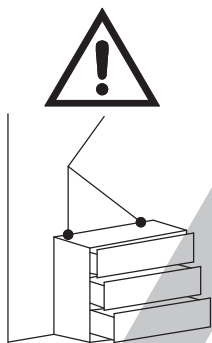

AVERTISSEMENT ANTI-RENVERSEMENT !

Les meubles renversés peuvent causer des blessures graves ou mortelles par écrasement. Pour éviter de basculer, assurez-vous d'utiliser la fixation murale, si elle n'est pas incluse avec le produit. Veillez acheter la fixation murale qui s'adapte à votre mur. En cas de doute, demandez conseil à un professionnel. Veillez lire et suivre attentivement chaque étape des instructions.

IMPORTANT !

Il est important que tout produit assemblé à l'aide de tout type de vis soit resserré 2 semaines après l'assemblage et une fois tous les 3 mois, afin d'assurer la stabilité tout au long de la durée de vie du produit.

Pour l'entretien régulier et le nettoyage du produit, pour le cadre, veuillez utiliser un chiffon trempé dans un nettoyant doux pour l'essuyer complètement, puis séchez-le avec un chiffon propre. Pour les matériaux en verre, essuyez avec un chiffon imbibé d'eau nettoyant pour vitres, puis séchez avec un chiffon sec.

N'utilisez pas de tournevis électrique et n'utilisez pas trop de force lors de l'installation, car la panneau est facile à casser.

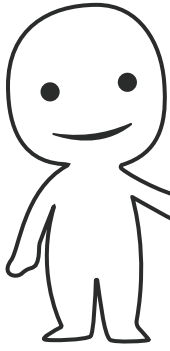

Please prepare the following tools
Veuillez préparer les outils suivants

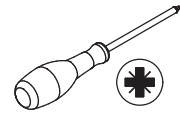
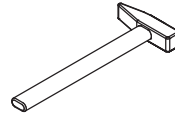
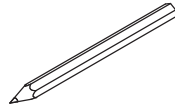

When installing, please carefully confirm whether each screw corresponds to the manual, accessories with similar shapes can be distinguished by size



Lors de l'installation, veuillez vérifier soigneusement si chaque vis correspond au manuel. Les accessoires de forme similaire peuvent être distingués par leur taille.

A x 192

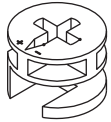

Ø 15 x 10 mm

B x 192

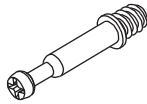

Ø 6 x 35 mm

C x 21

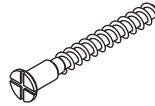

Ø 5 x 40 mm

D x 102

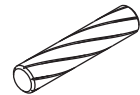

Ø 6 x 30 mm

E x 4

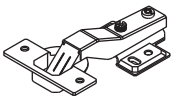

F x 4

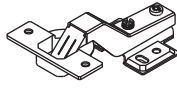

G x 4

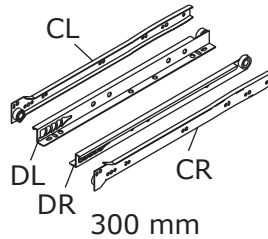

H x 32



Ø 3.5 x 12 mm

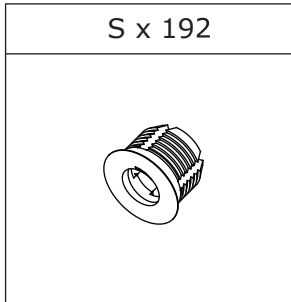
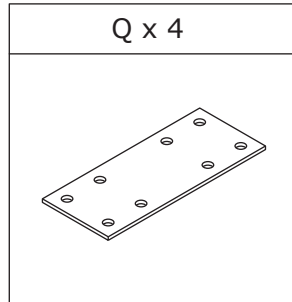
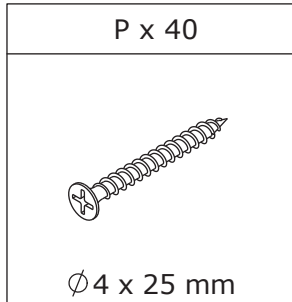
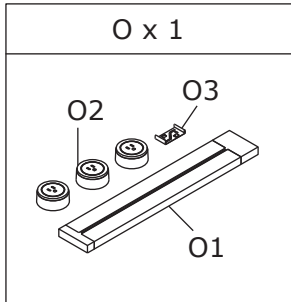
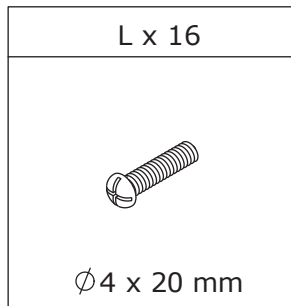
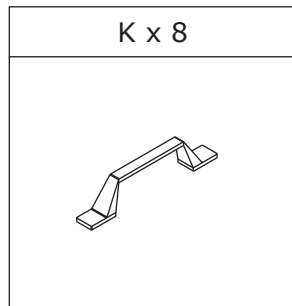
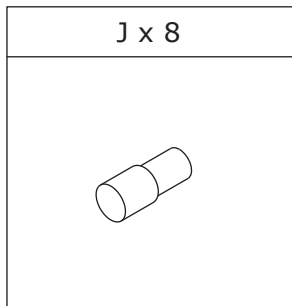
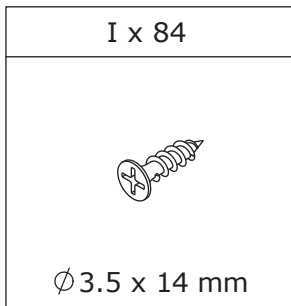

⚠ WARNING



Children have died from furniture tipover. To reduce the risk of furniture tipover:

- ALWAYS install Anti-tip device provided.
- NEVER put a TV on this product.
- NEVER allow children to stand, climb or hang on any drawers, doors, or shelves.
- NEVER open more than one drawer at a time.
- Place heaviest items in the lowest drawers.



*This is a permanent label.
Do not remove!*

⚠ AVERTISSEMENT



Des enfants sont morts à cause du renversement de meubles :

-TOUJOURS installer le dispositif anti-basculement fourni.

- N'installez jamais un téléviseur sur ce produit.
- NE jamais permettre aux enfants de se tenir debout, de grimper ou de s'accrocher aux tiroirs, aux portes ou aux étagères.
- N'ouvrez jamais plus d'un tiroir à la fois.
- Placez les objets les plus lourds dans les tiroirs les plus bas.



*Il s'agit d'une étiquette permanente.
Ne l'enlevez pas !*

INSTRUCTION FOR USE MODE D'EMPLOI

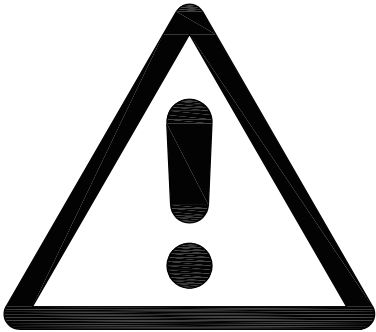

DO NOT MOVE SOCKET
WHEN POWERED ON (O2)

NE PAS DÉPLACER LA PRISE
LORSQUE L'APPAREIL EST
SOUS TENSION (O2)

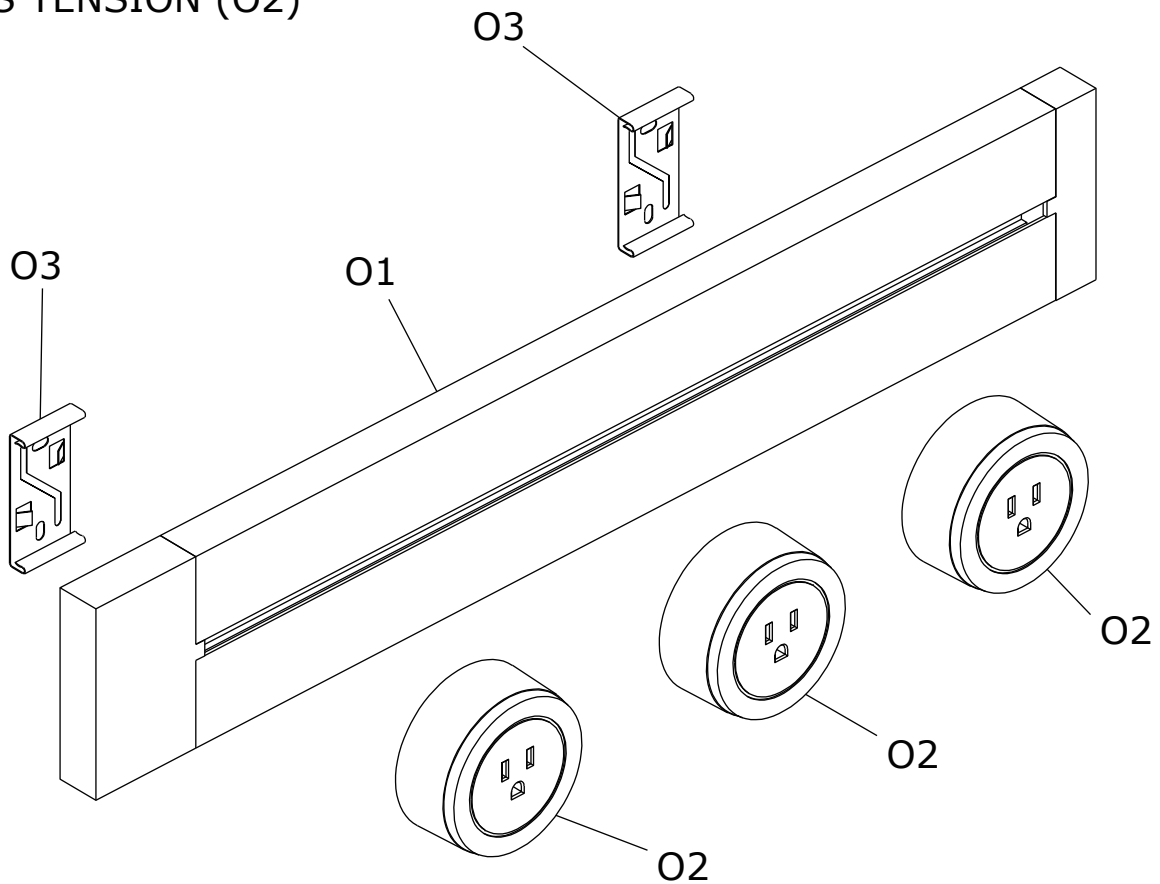
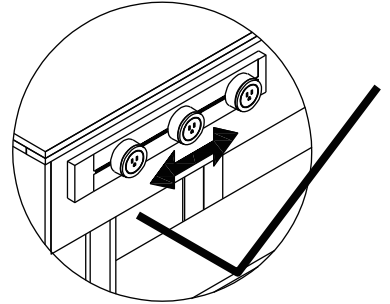
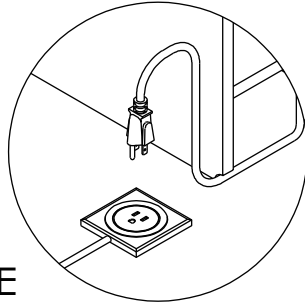
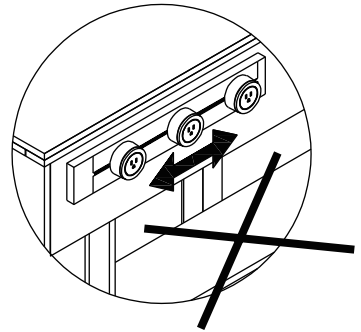
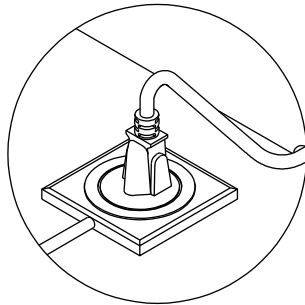

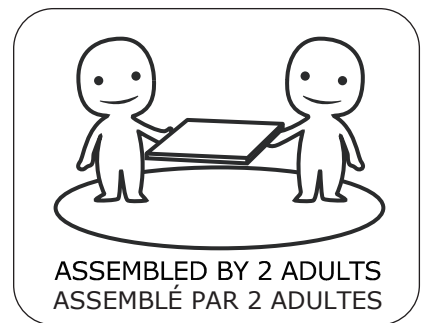
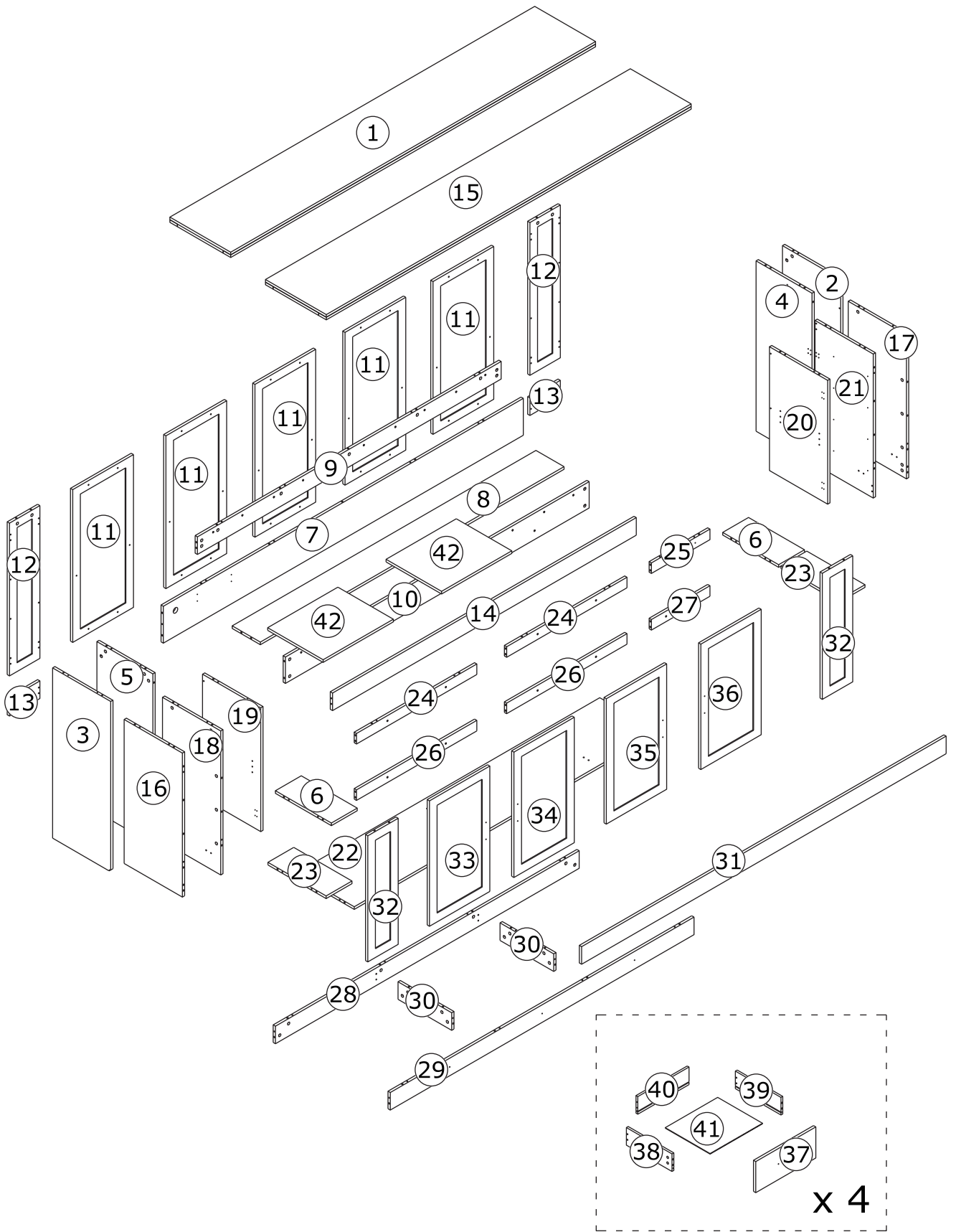

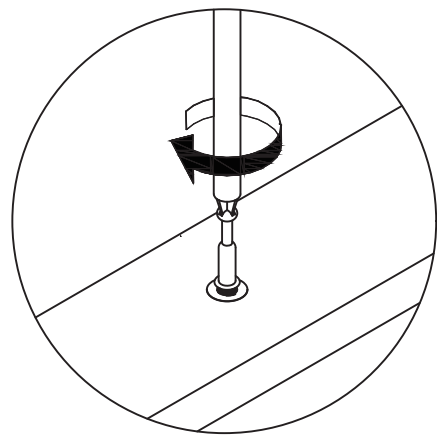
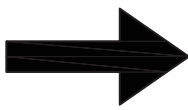
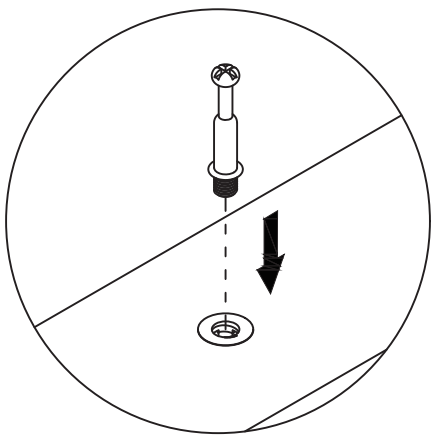
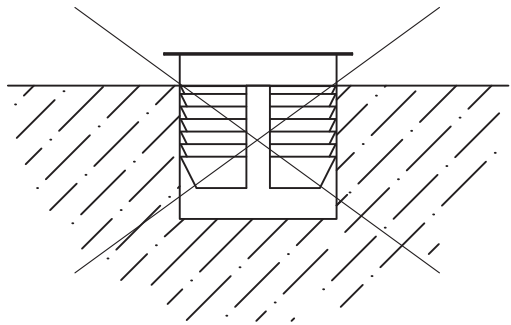
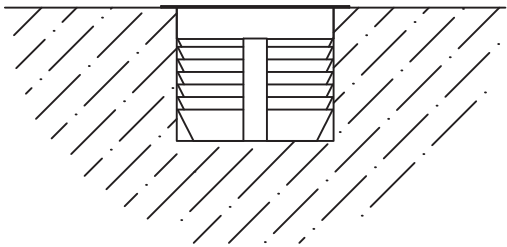
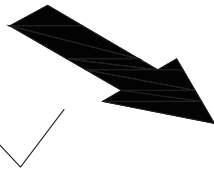
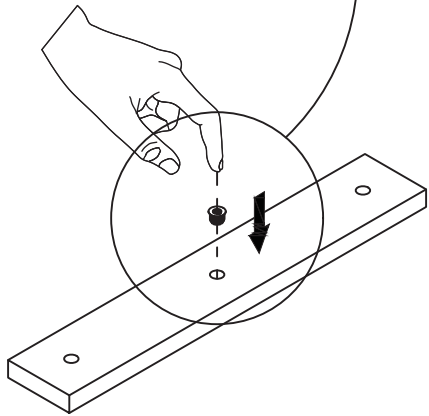
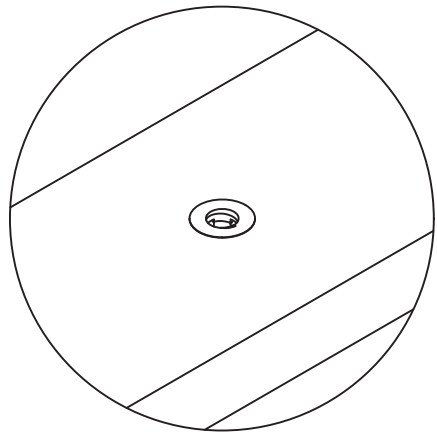
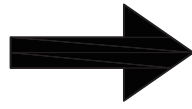
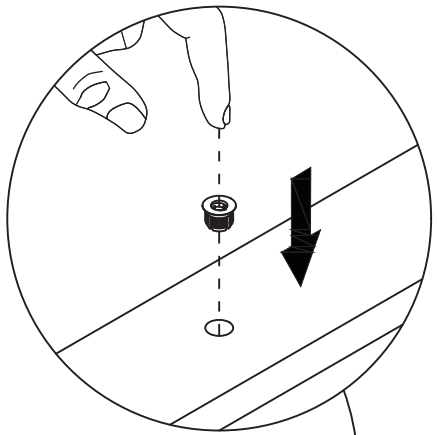

1

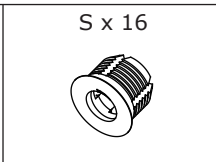
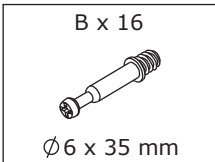

Screw eccentric rod(B) into board 4 and 5 at first.

Flip the two to back, screw eccentric rod(B) into as well.

Vissez d'abord la tige excentrique (B) dans les planches 4 et 5.

Retournez les deux planches, puis vissez également la tige excentrique (B) dans celles-ci.

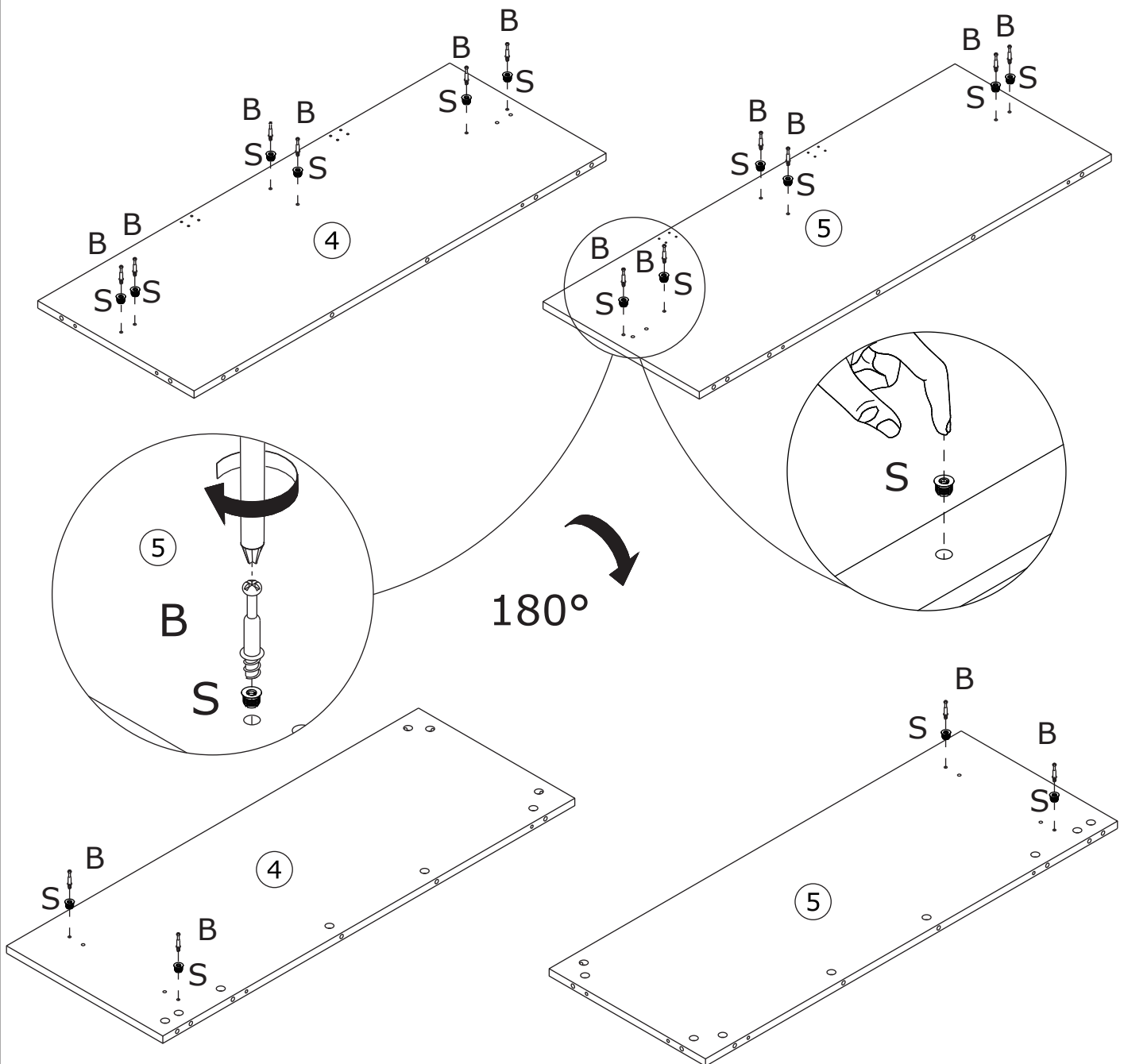
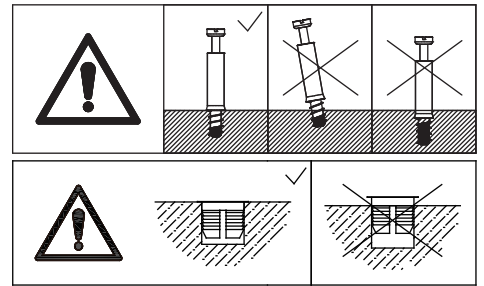

2

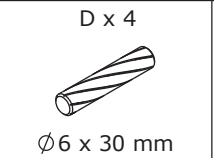
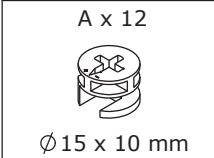

Insert wooden dowel(D) into board 14 at first. Connect board 4 and 5 to board 9, 8, 10 and 14, add cam lock(A) into board 9, 8, 10 and turn clockwise to tighten as shown.

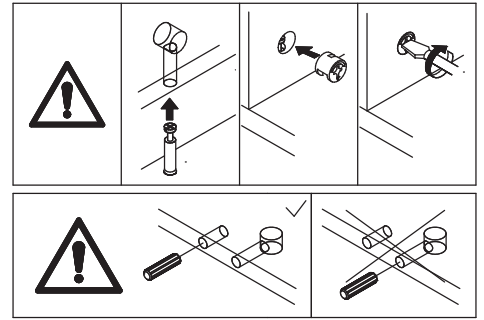

Insérez d'abord la cheville en bois (D) dans la planche 14.
Reliez les planches 4 et 5 aux planches 9, 8, 10 et 14, ajoutez le verrou à came (A) dans les planches 9, 8, 10 et tournez dans le sens des aiguilles d'une montre pour serrer comme indiqué.

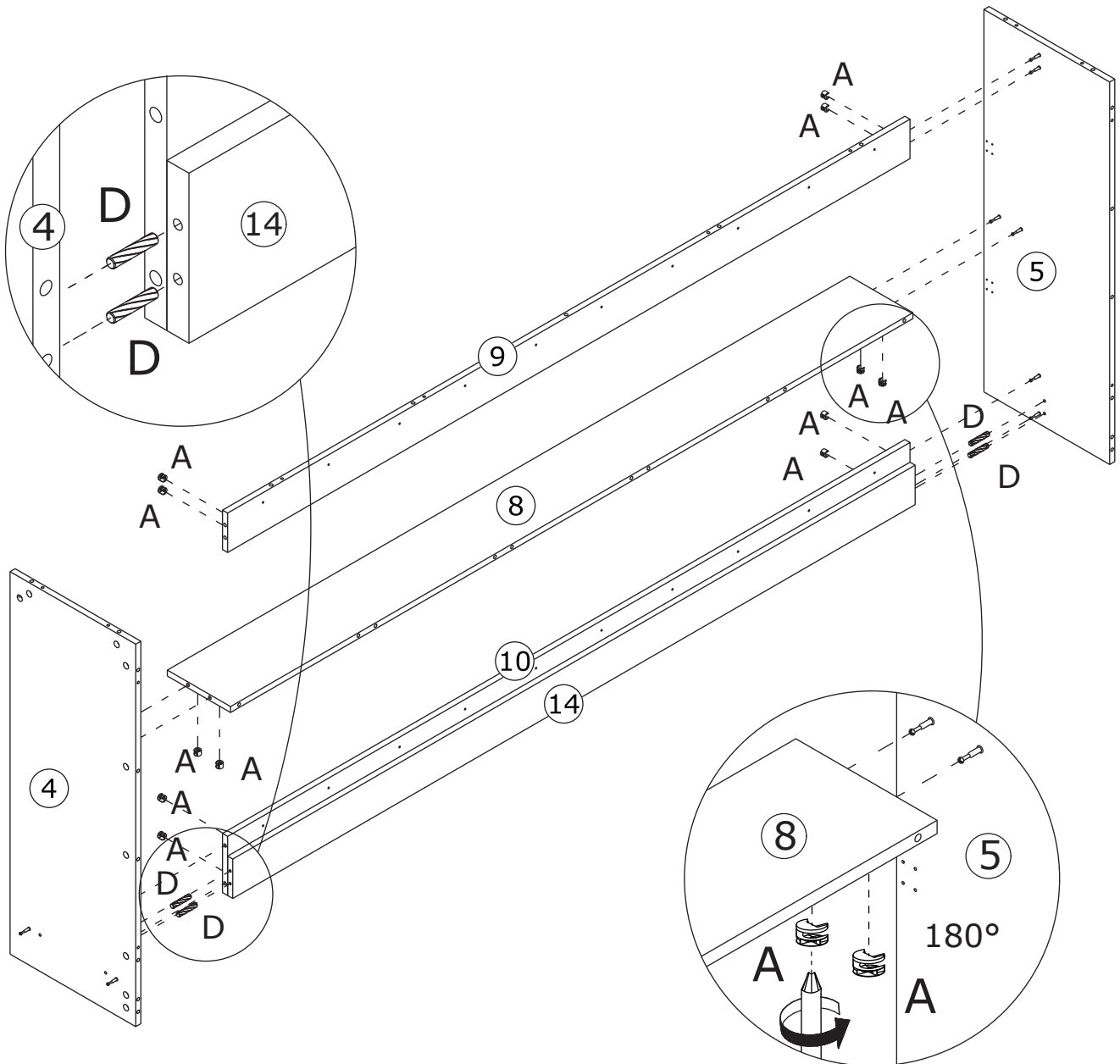

3

P x 3

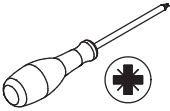
Ø4 x 25 mm

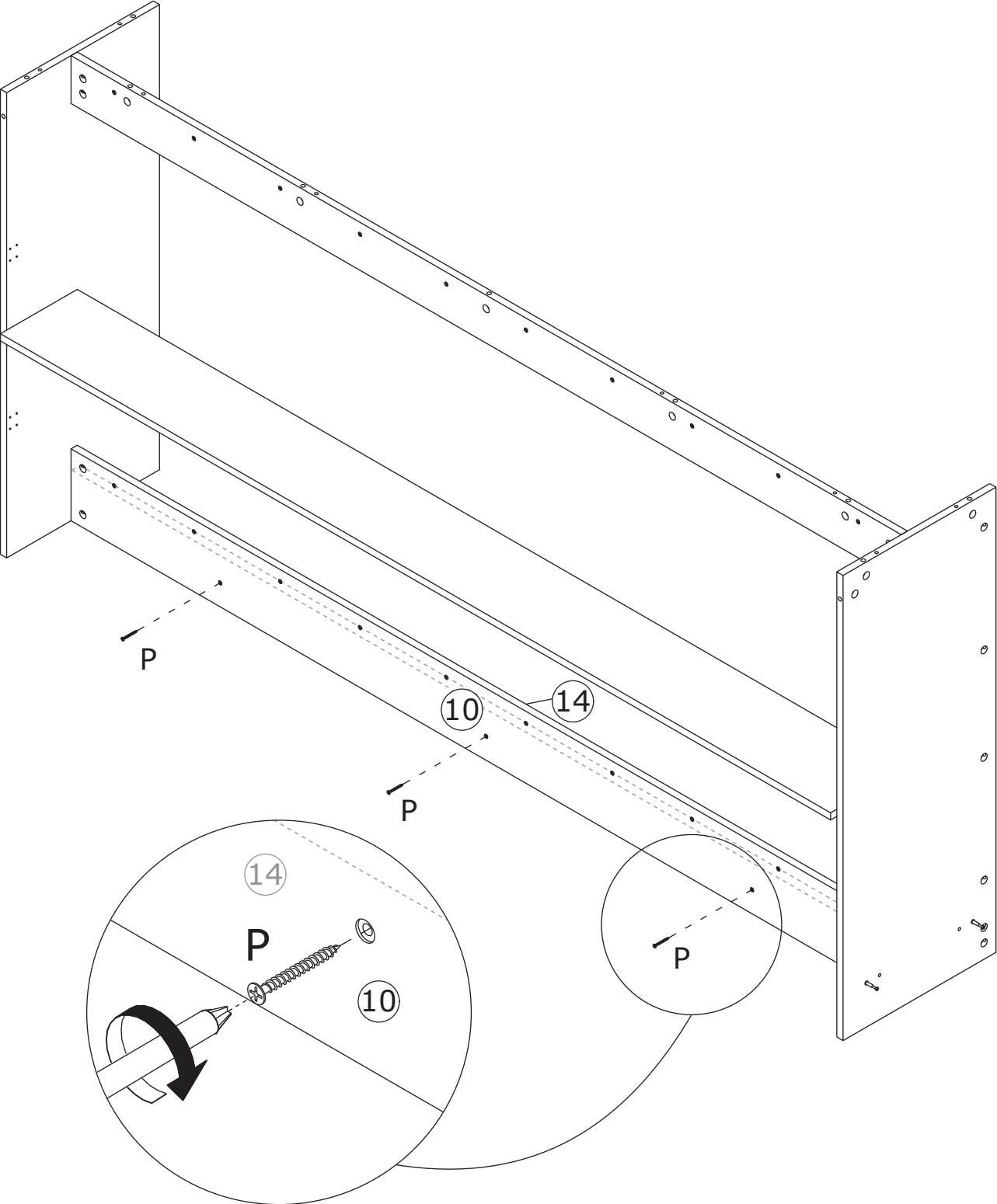

Fix board 10 to board 14 using screw(P) as shown.

Fixez la planche 10 à la planche 14 à l'aide de la vis (P) comme indiqué.



4

A x 4



Ø15 x 10 mm

D x 4

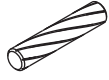

Ø6 x 30 mm

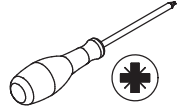

Attach board 6 to board 4 and 5 using wooden dowel(D), add cam lock(A) into board 6 and turn clockwise to tighten as shown.

Fixez la planche 6 aux planches 4 et 5 à l'aide du goujon en bois (D), ajoutez le verrou à came (A) dans les planches 4 et 5 et tournez dans le sens des aiguilles d'une montre pour serrer comme indiqué.

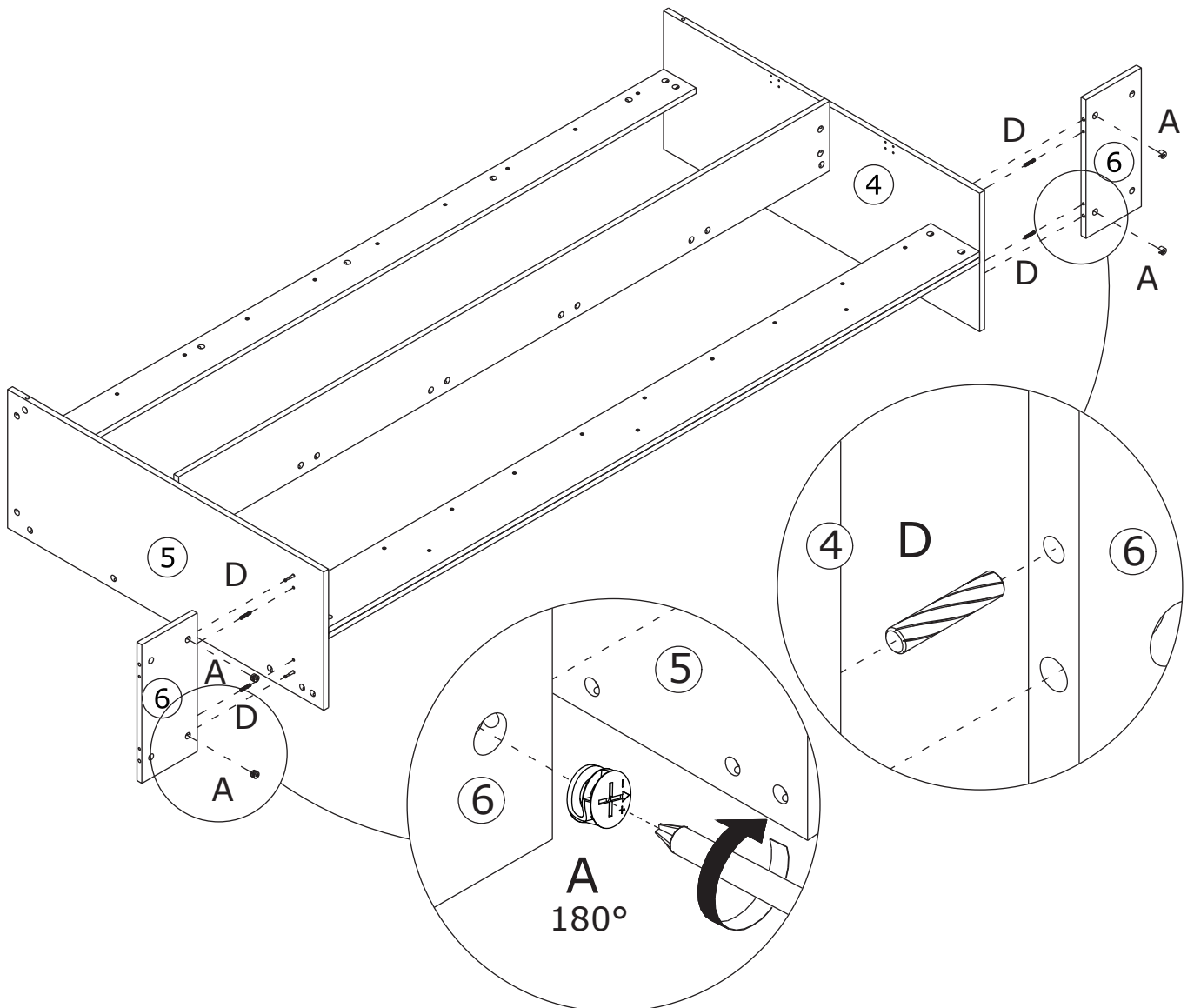
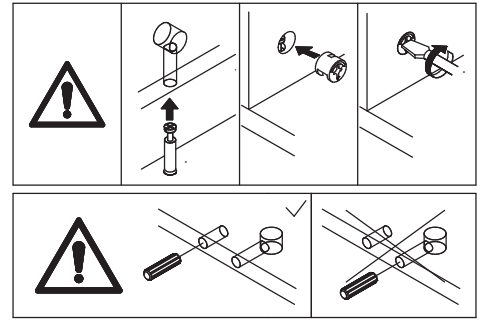

5

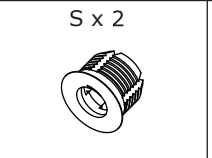
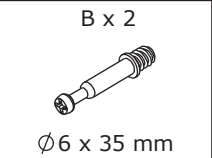
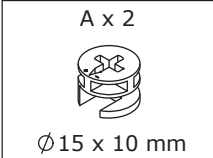

Screw eccentric rod(B) into board 7 at first. Attach board 7 to board 4 and 5, add cam lock(A) into board 4,5 and turn clockwise to tighten as shown.

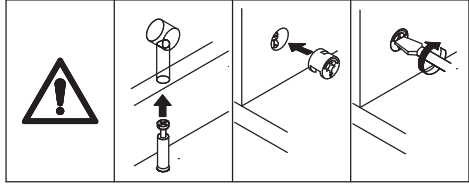
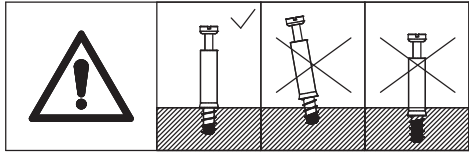

Visser d'abord la tige excentrique (B) dans la planche 7.

Fixer la planche 7 aux planches 4 et 5, ajouter le verrou à came (A) dans les planches 4 et 5 et tourner dans le sens des aiguilles d'une montre pour serrer comme indiqué.

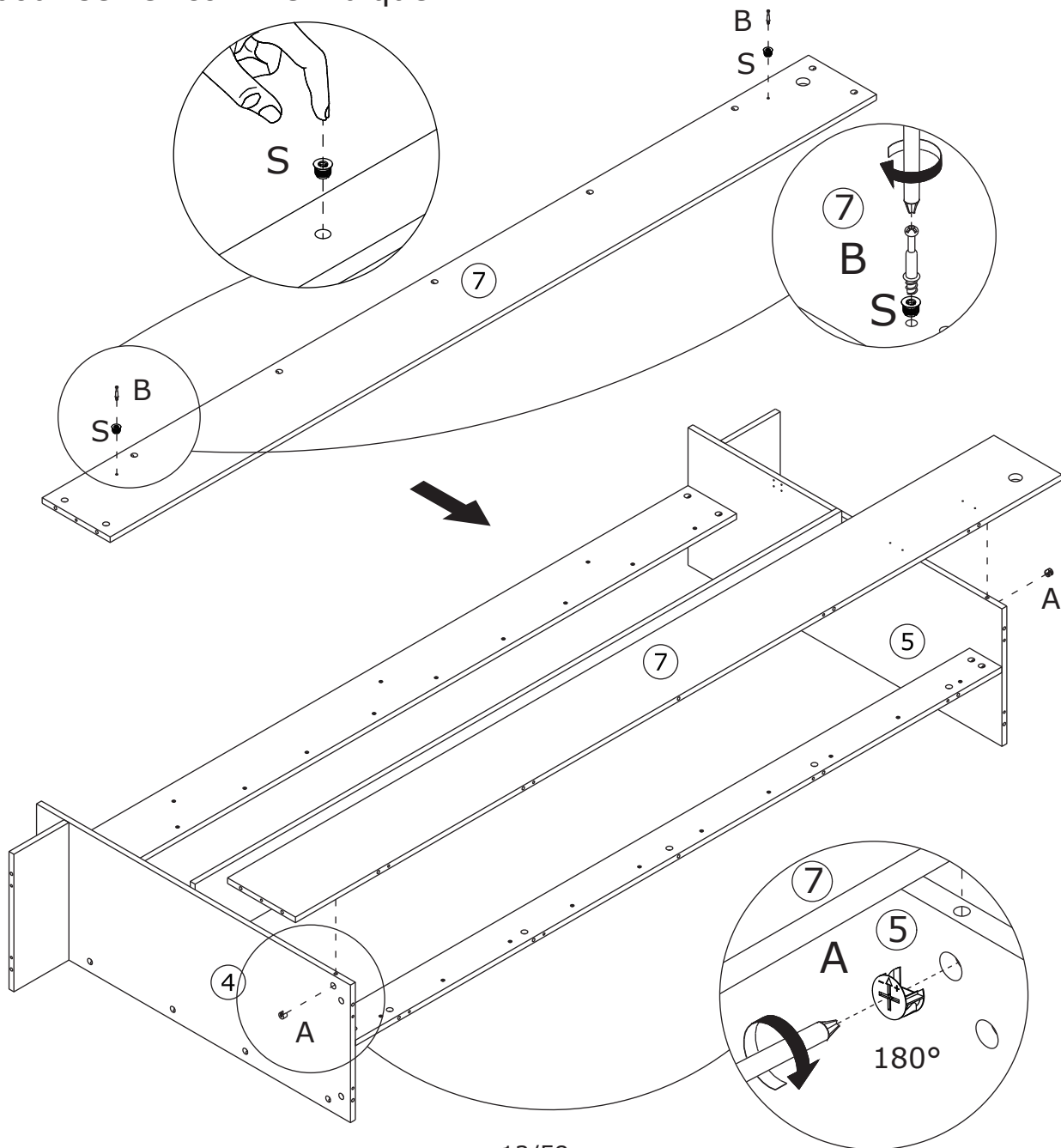

6

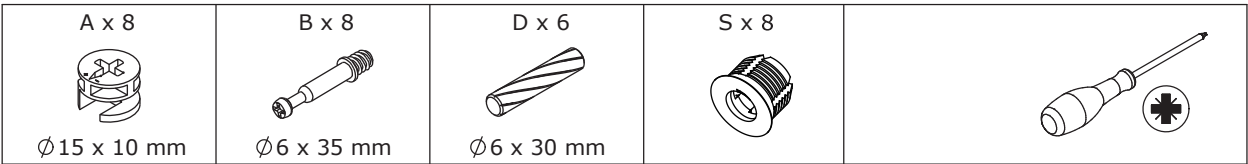

Screw eccentric rod(B) into board 2 and 3 at first.

Attach board 2 and 3 to board 6 and 7 using wooden dowel(D), add cam lock(A) into board 6, 7 and turn clockwise to tighten as shown.

Vissez d'abord la tige excentrique (B) dans les planches 2 et 3.

Fixez les planches 2 et 3 aux planches 6 et 7 à l'aide de chevilles en bois (D), ajoutez le verrou à came (A) dans les planches 6 et 7 et tournez dans le sens des aiguilles d'une montre pour serrer comme indiqué.

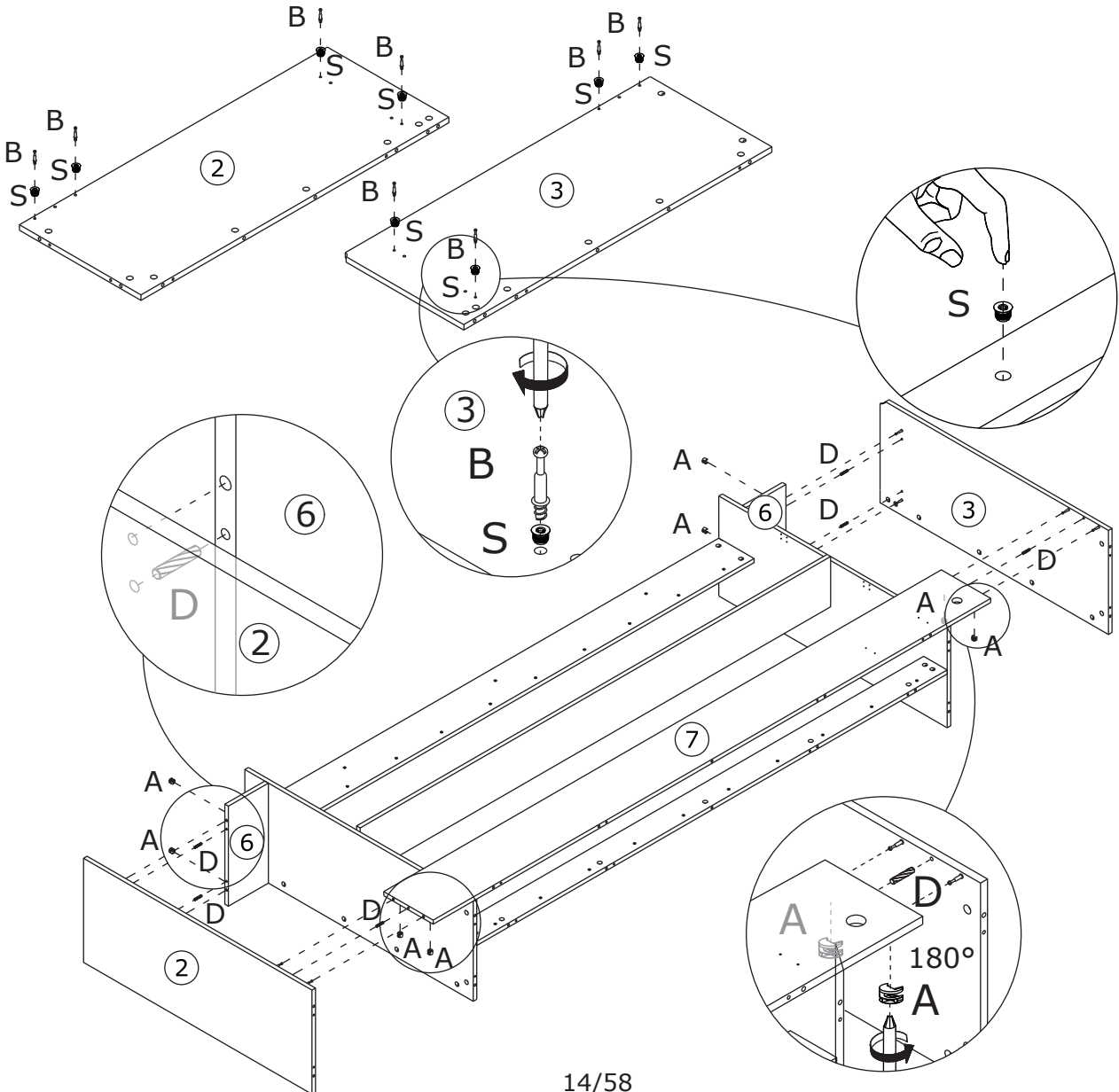
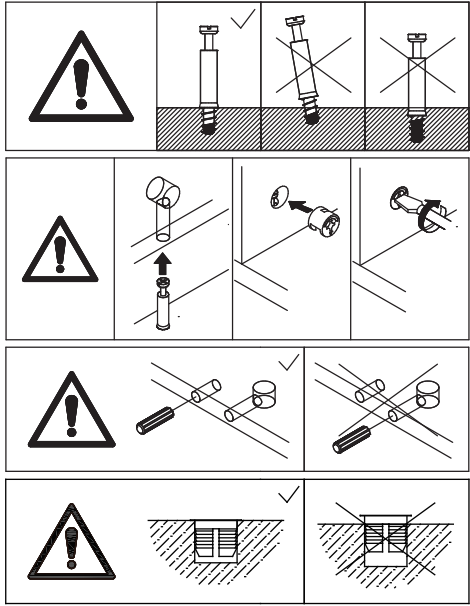

7

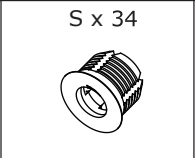
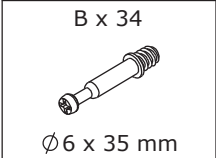

Screw eccentric rod(B) into board 12, 13 and 11 at first.

Vissez d'abord la tige excentrique (B) dans les planches 12, 13 et 11.

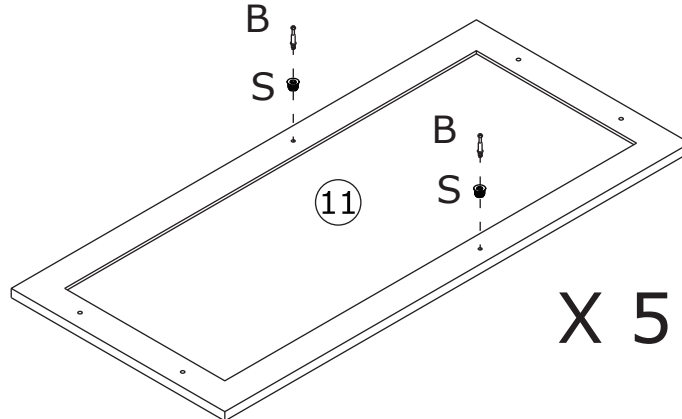
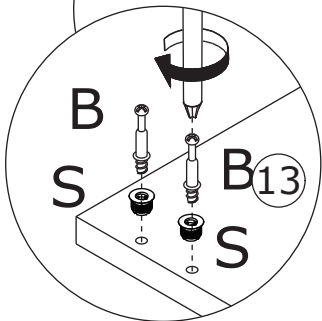
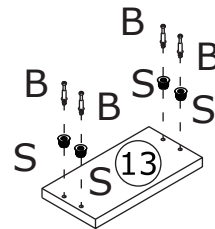
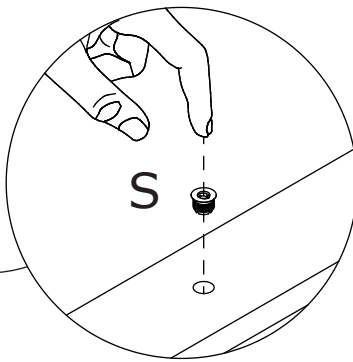
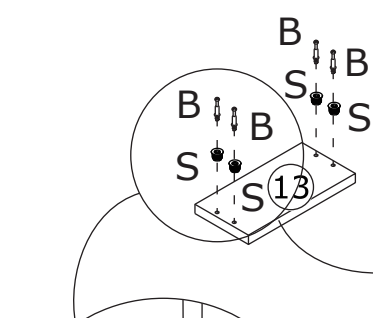
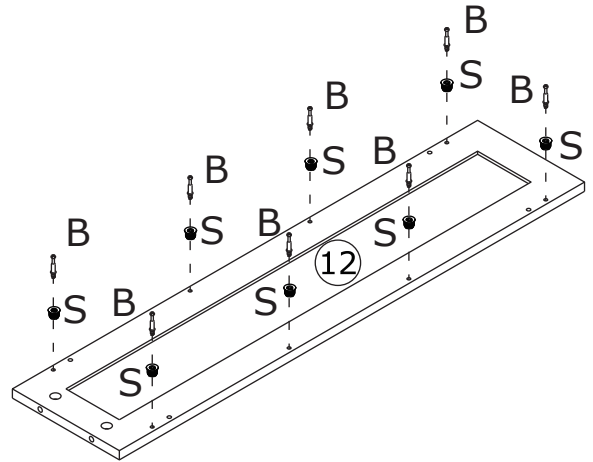
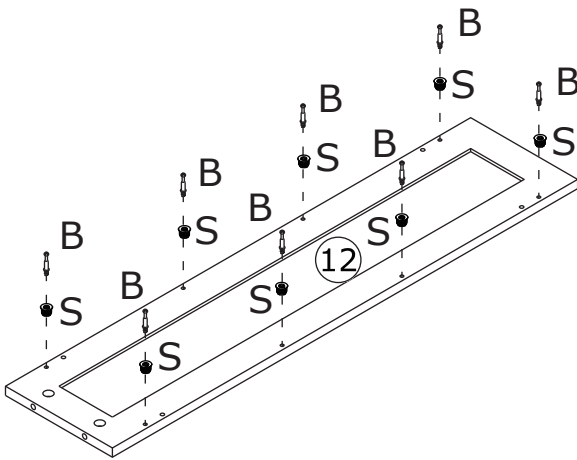
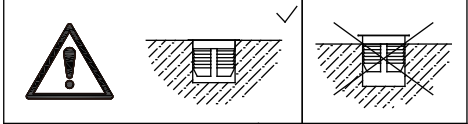
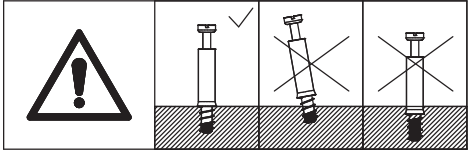

8

Attach board 13 to board 2, 4 and 5, 3 as shown.

Fixez la planche 13 aux planches 2, 4, 5 et 3
comme indiqué.

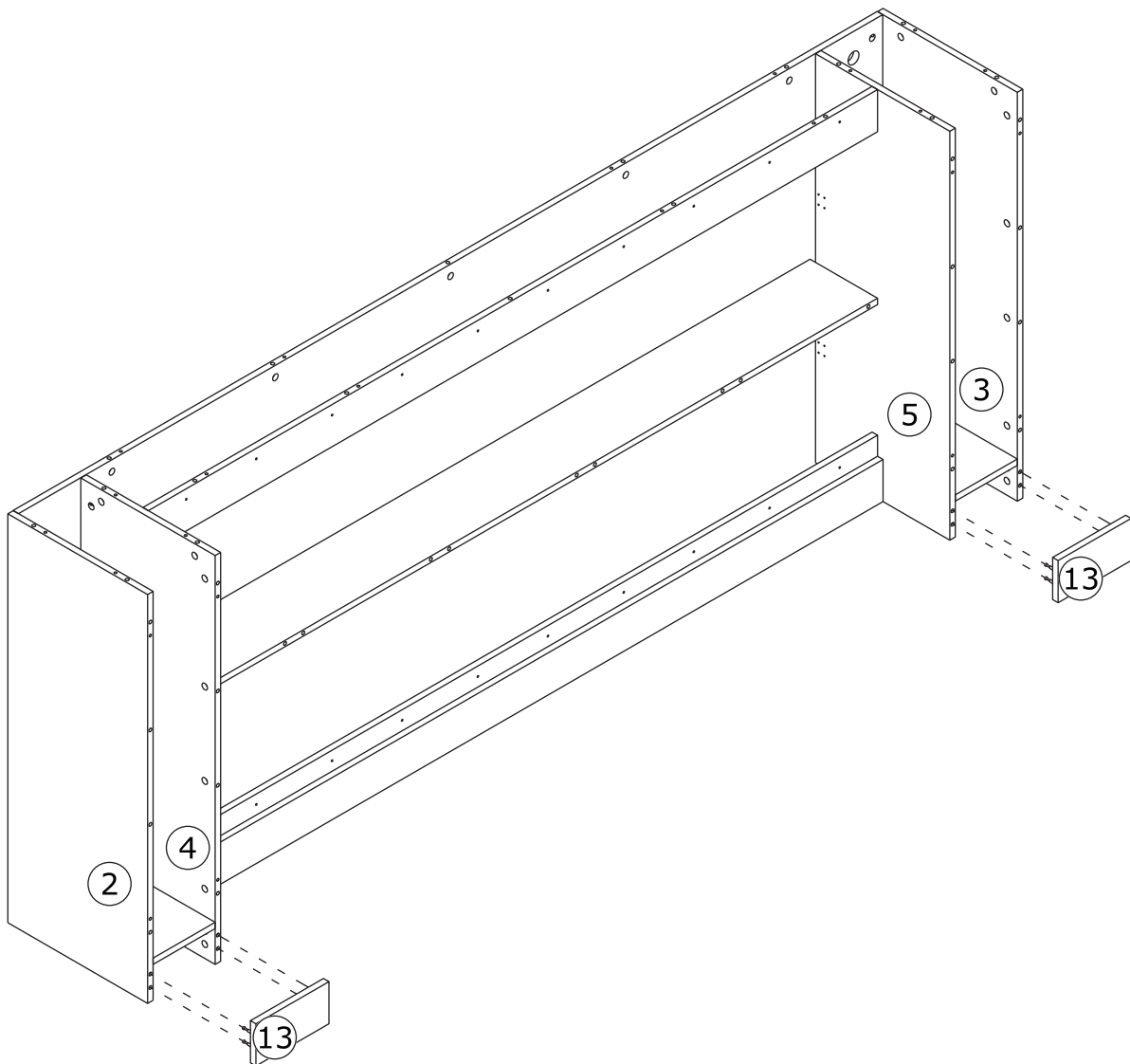

9



Attach board 12 to board 2, 4 and 5, 3 using wooden dowel(D), add cam lock(A) into board 2, 4, 5, 3 and turn clockwise to tighten as shown.

Fixez la planche 12 aux planches 2, 4, 5 et 3 à l'aide de chevilles en bois (D), ajoutez le verrou à came (A) dans les planches 2, 4, 5 et 3, puis tournez dans le sens des aiguilles d'une montre pour serrer comme indiqué.

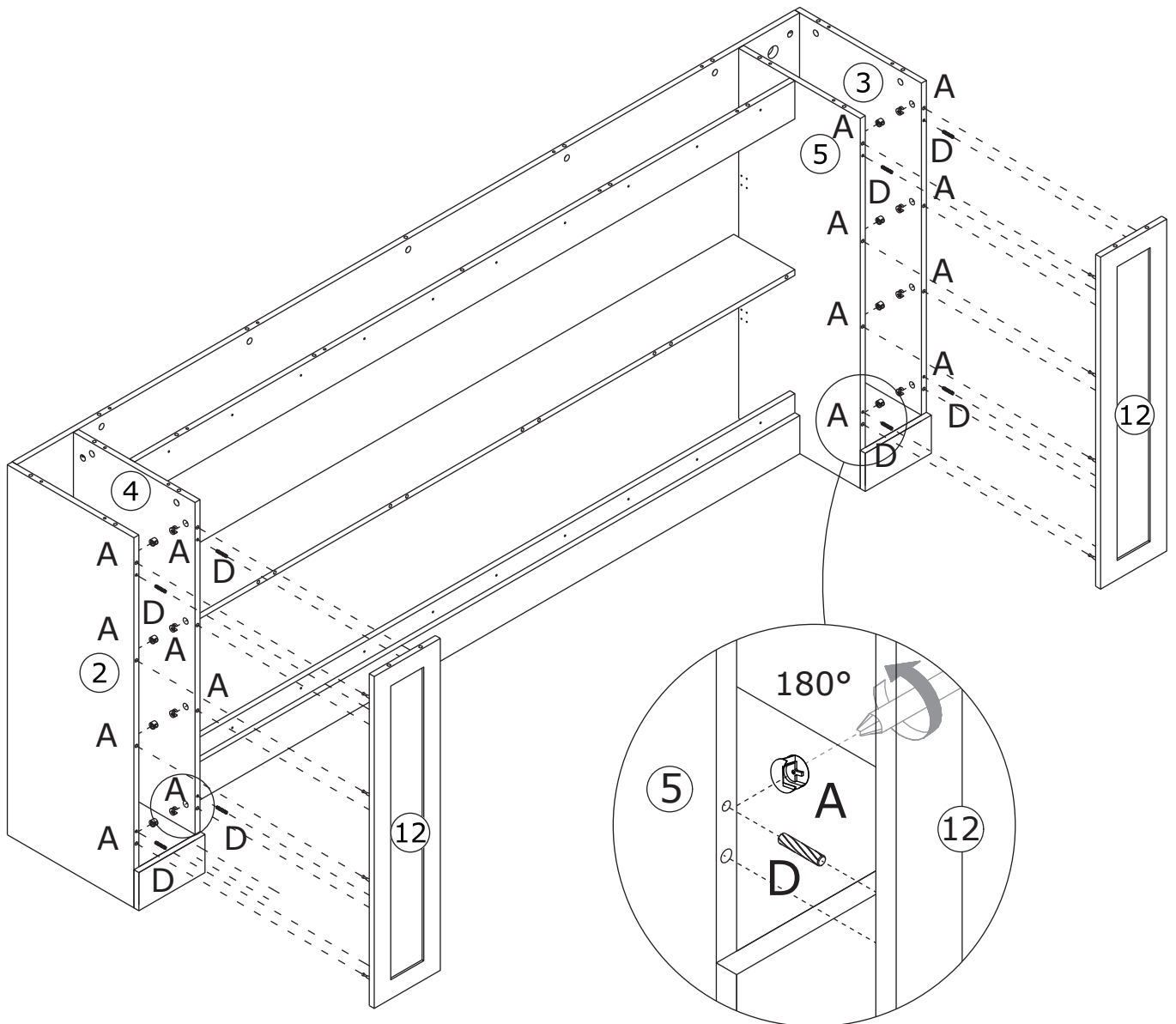
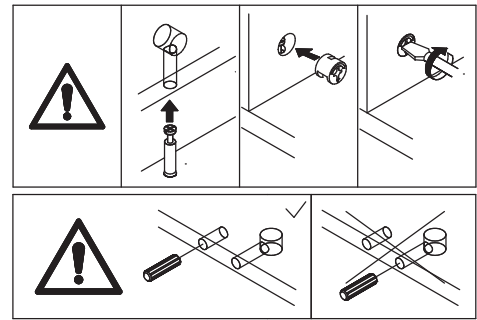

10

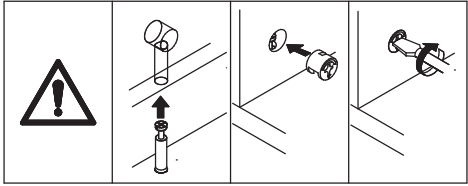
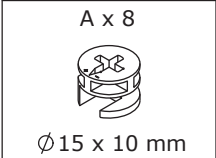

Add cam lock(A) into board 2, 4, 5, 3 and turn clockwise to tighten as shown.

Ajoutez le verrou à came (A) dans les planches 2, 4, 5, 3 et tournez dans le sens des aiguilles d'une montre pour serrer comme indiqué.

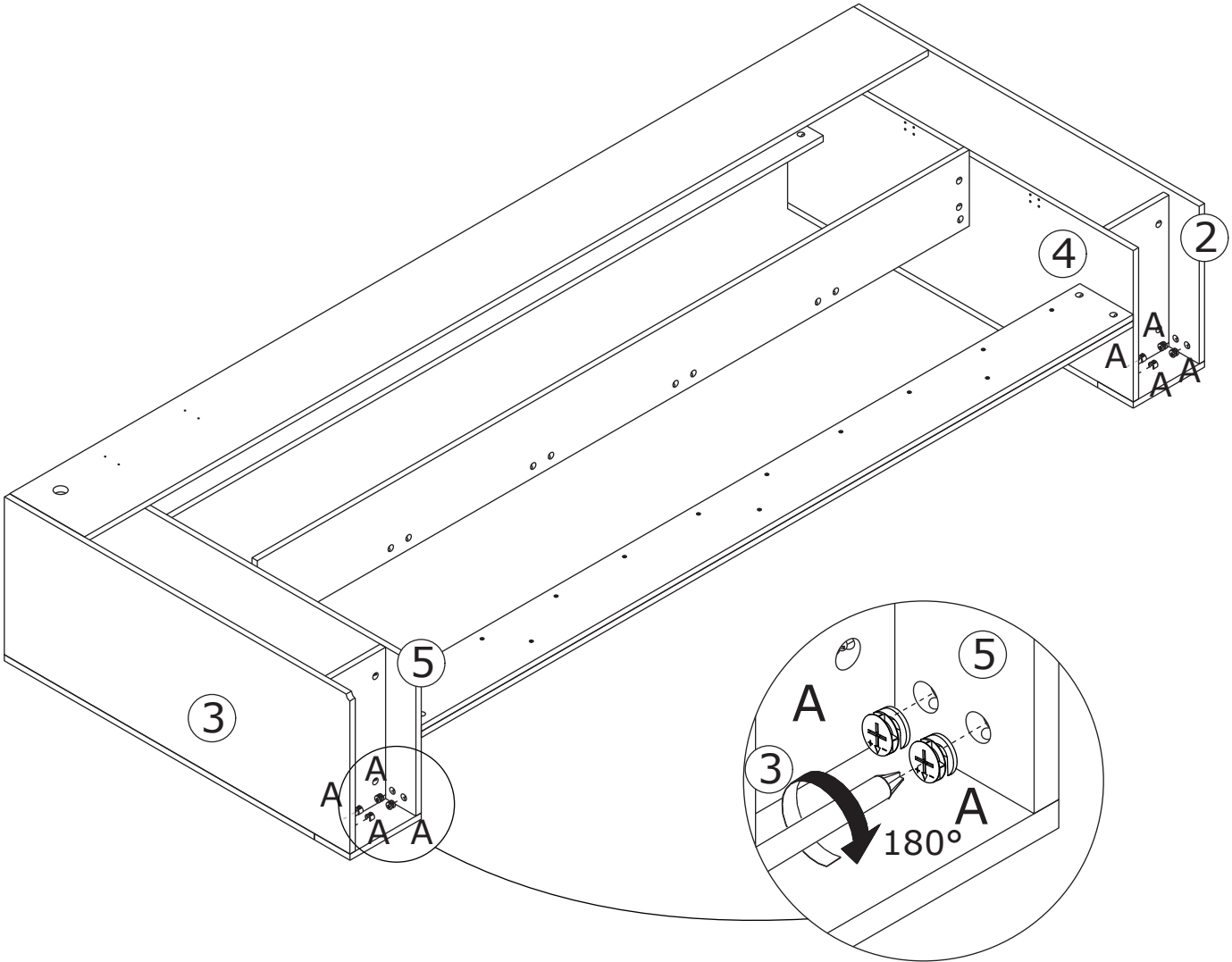

11

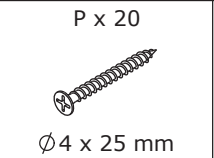
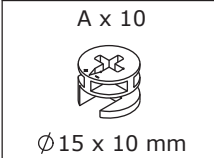

Attach board 11 to board 8, add cam lock(A) into board 8 and turn clockwise to tighten at first.
Fix board 11 to board 9 and 10 using screw(P) as shown.

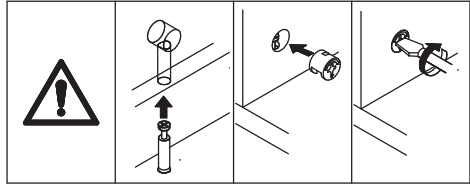

Fixez la planche 11 à la planche 8, ajoutez le verrou à came (A) dans la planche 8 et tournez dans le sens des aiguilles d'une montre pour serrer dans un premier temps.
Fixez la planche 11 aux planches 9 et 10 à l'aide de la vis (P) comme indiqué.

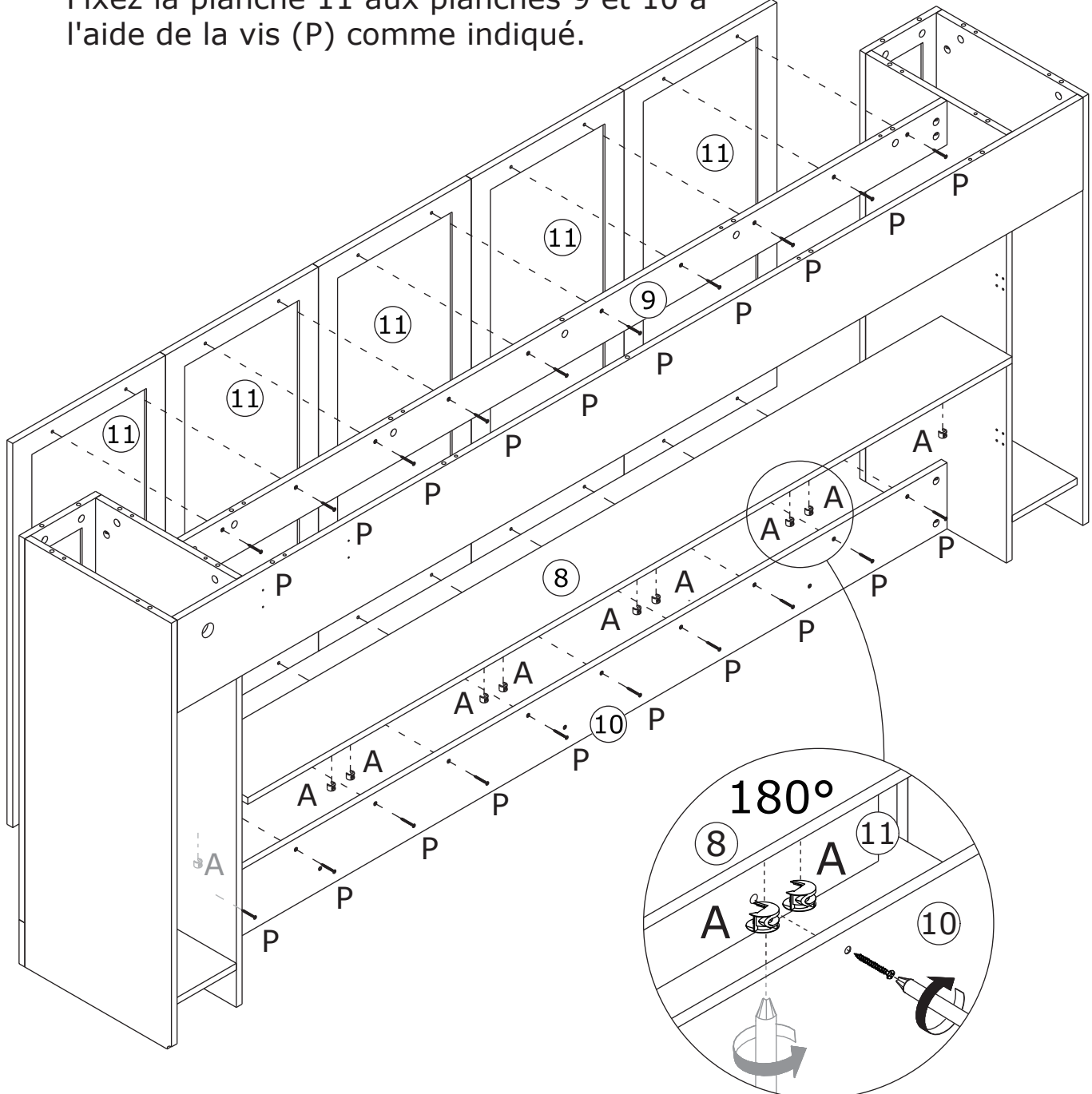

12

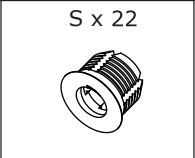
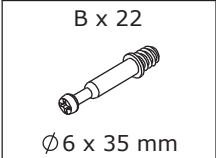

Screw eccentric rod(B) into board 1 at first.

Vissez d'abord la tige excentrique (B) dans la planche 1.

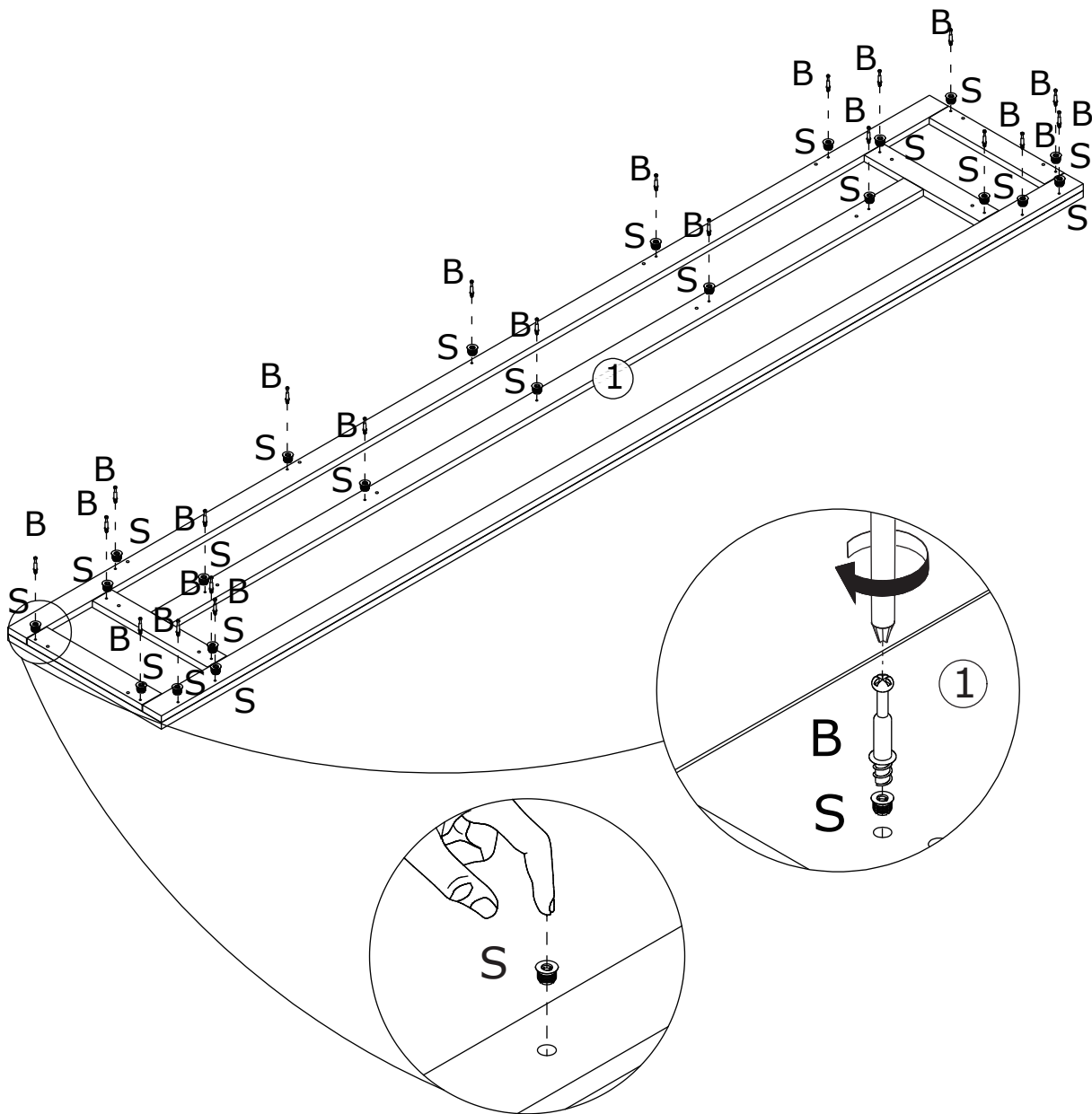
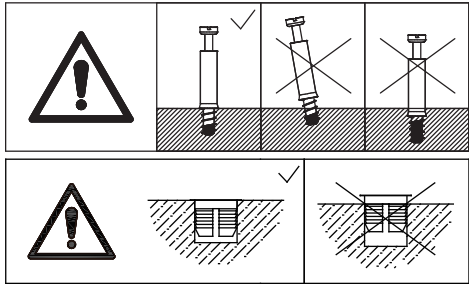

13

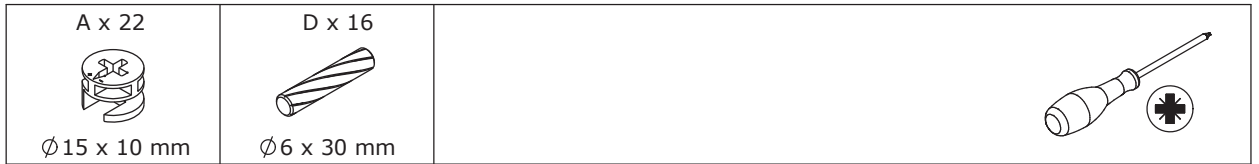

Attach board 1 to top using wooden dowel(D), add cam lock(A) into and turn clockwise to tighten as shown.

Fixez la planche 1 au sommet à l'aide d'un goujon en bois (D), ajoutez le verrou à came (A) et tournez dans le sens des aiguilles d'une montre pour serrer comme indiqué.

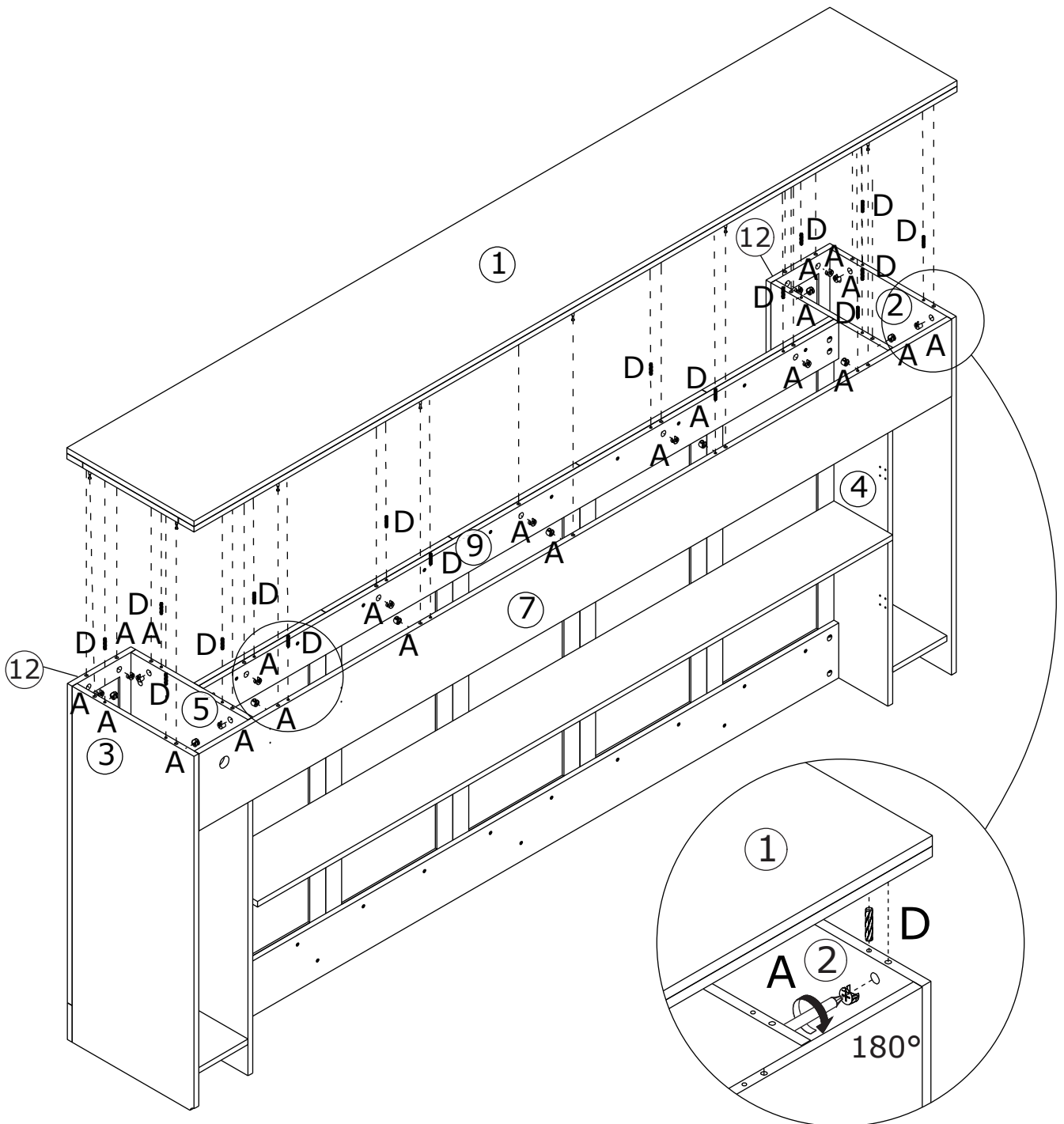
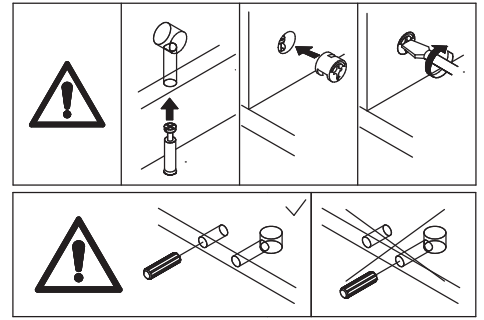

14

B x 20



S x 20

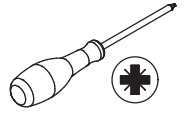

Screw eccentric rod(B) into board 22, 28, 29 and 31 at first.

Vissez d'abord la tige excentrique (B) dans les planches 22, 28, 29 et 31.

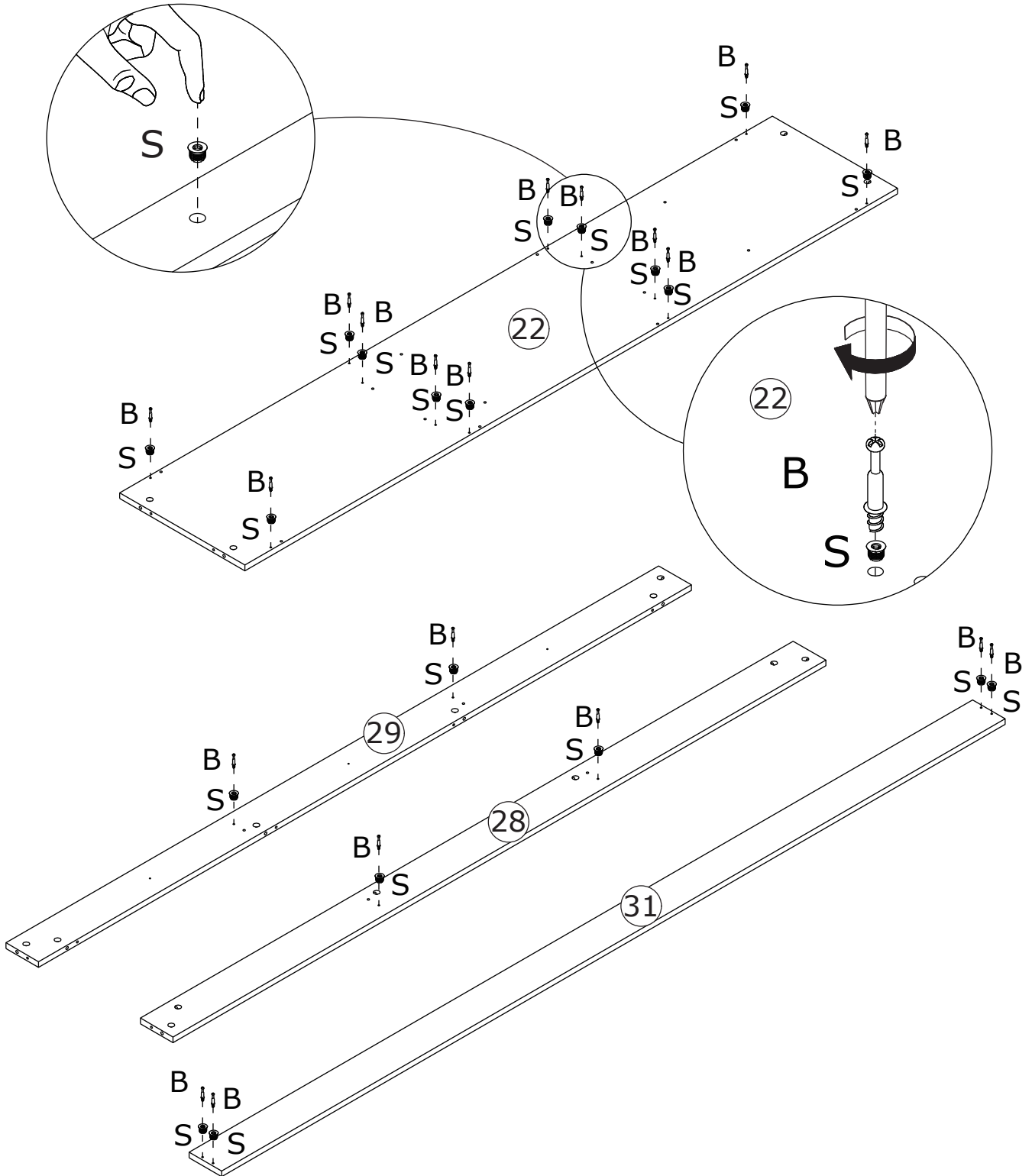
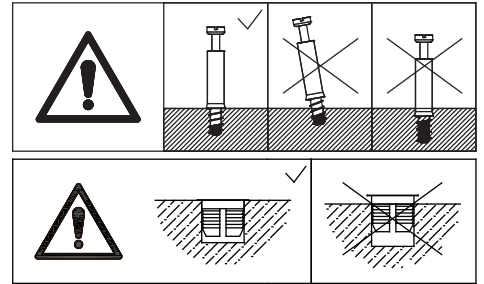

15

A x 4



Ø 15 x 10 mm

D x 4

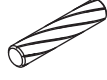

Ø 6 x 30 mm

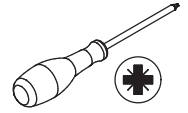

Connect board 30 to board 28 and 29 using wooden dowel(D), add cam lock(A) into board 30 and turn clockwise to tighten as shown.

Reliez la planche 30 aux planches 28 et 29 à l'aide d'un goujon en bois (D), ajoutez le verrou à came (A) dans la planche 30 et tournez dans le sens des aiguilles d'une montre pour serrer comme indiqué.

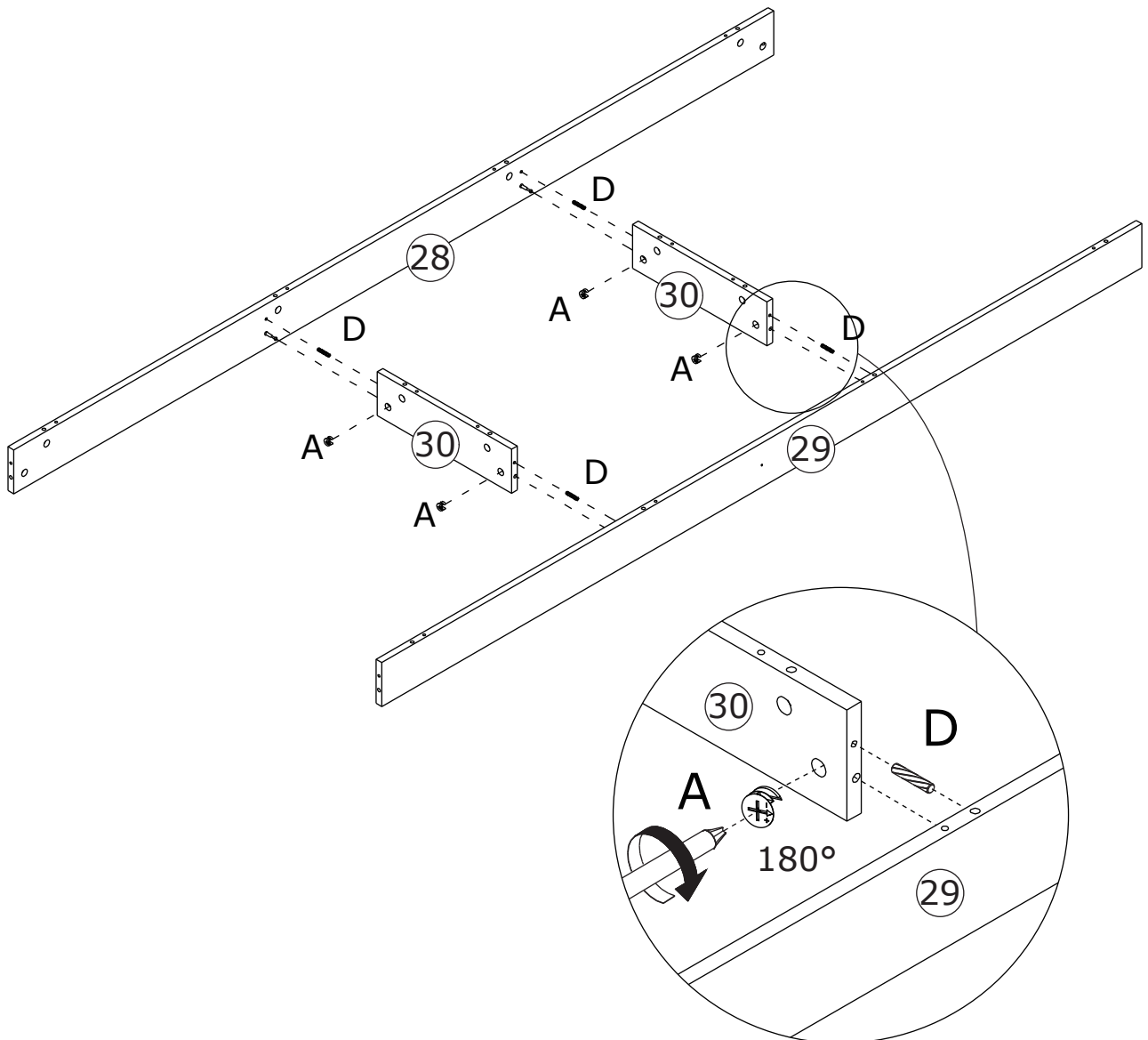
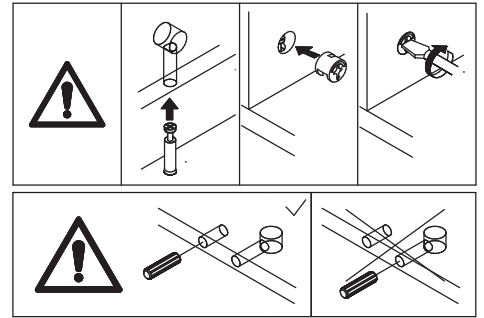

16

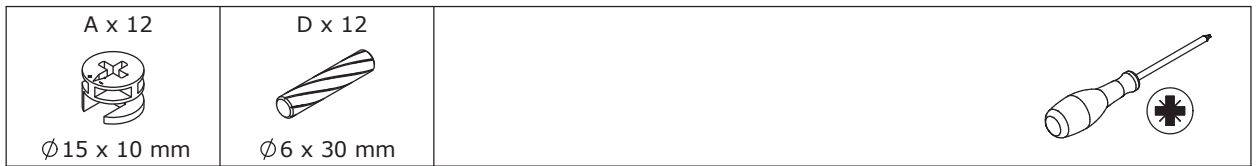

Attach board 28, 30 and 29 to board 22 using wooden dowel(D), add cam lock(A) into and turn clockwise to tighten as shown.

Fixez les planches 28, 30 et 29 à la planche 22 à l'aide d'un goujon en bois (D), ajoutez le verrou à came (A) et tournez dans le sens des aiguilles d'une montre pour serrer comme indiqué.

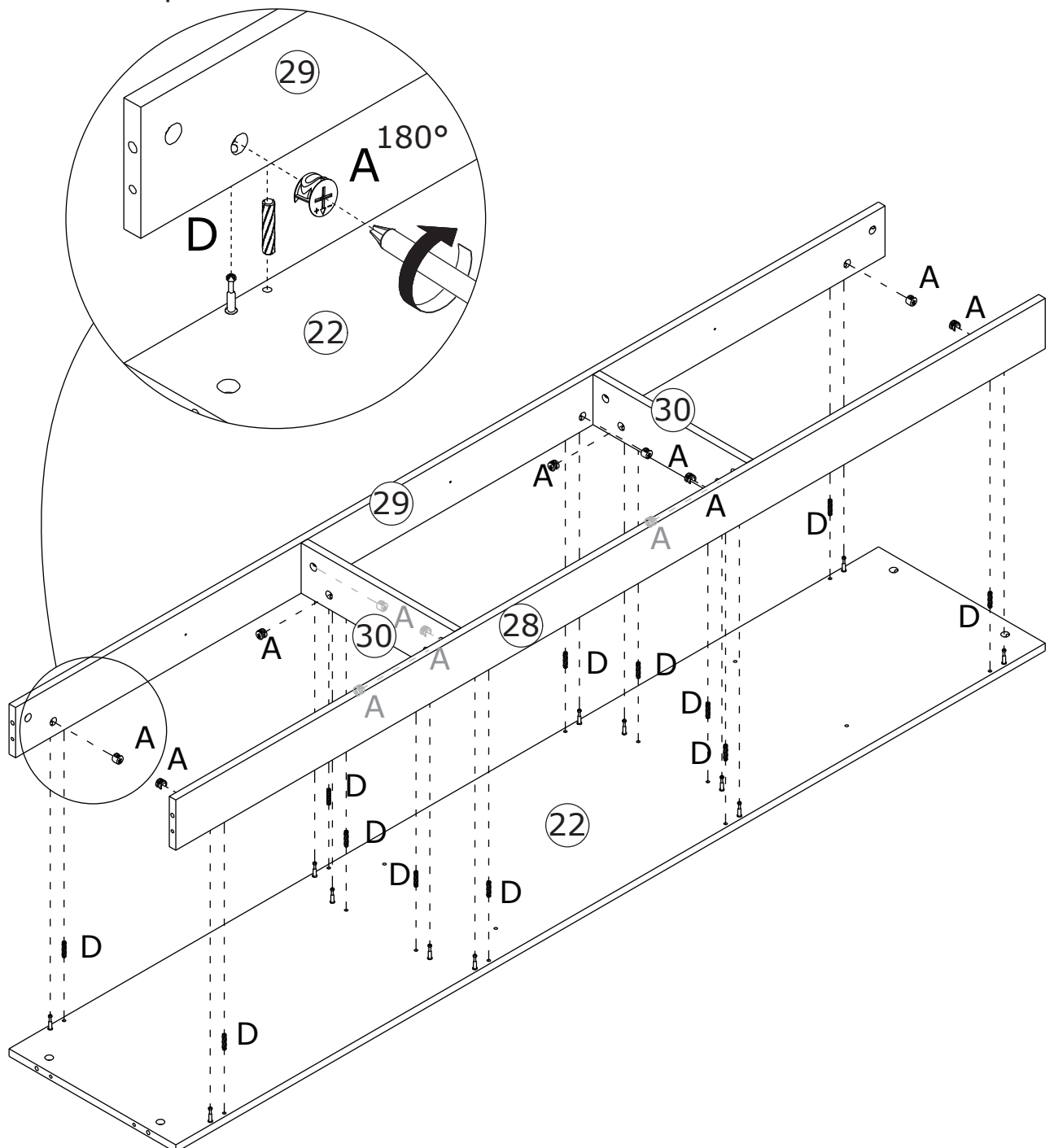
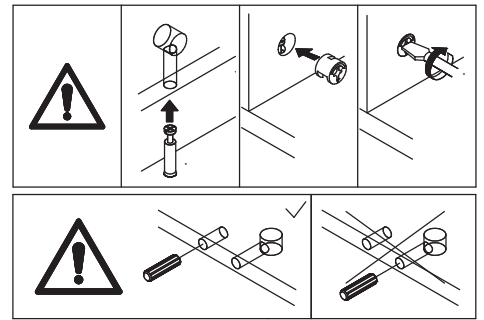

17

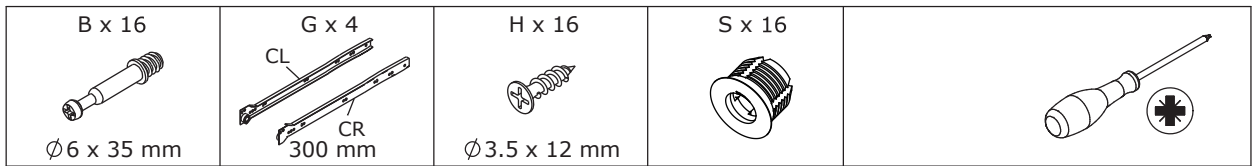

Screw eccentric rod (B) into board 20 and 21, fix rail (CL) and (CR) with screw (H) at first.
Flip the two to back, screw eccentric rod (B) into as well.

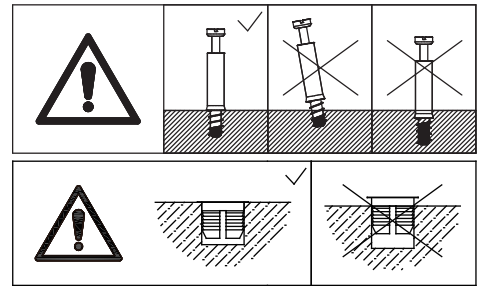

Vissez la tige excentrique (B) dans les planches 20 et 21, fixez d'abord les rails (CL) et (CR) à l'aide de la vis (H).

Retournez les deux vers l'arrière, vissez également la tige excentrique (B).

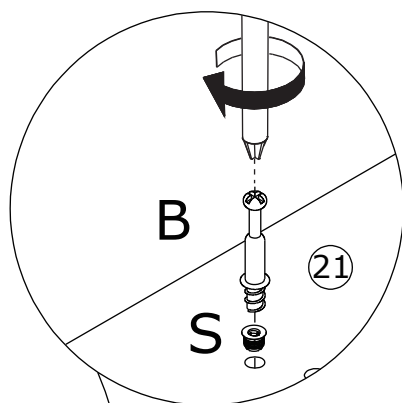
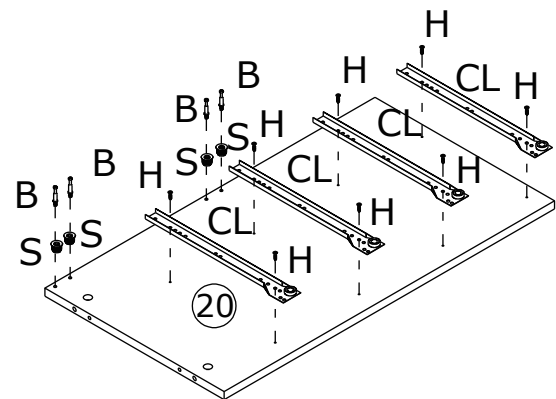
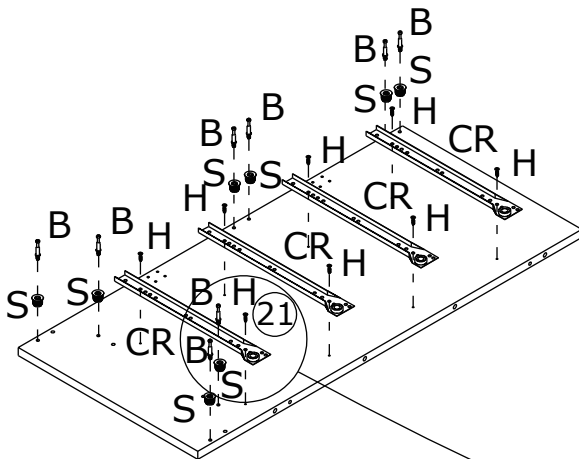
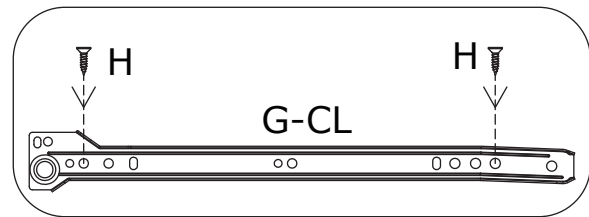
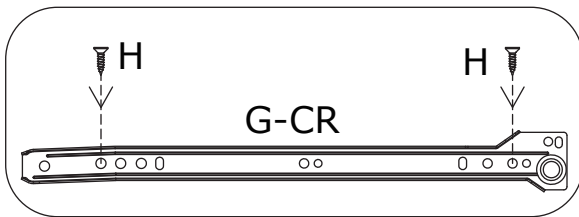

180°

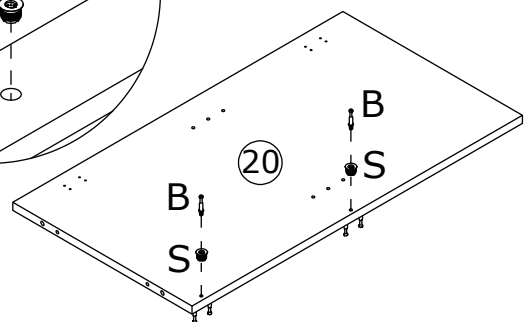
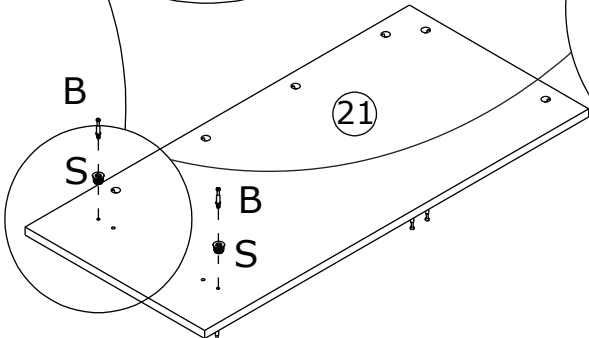
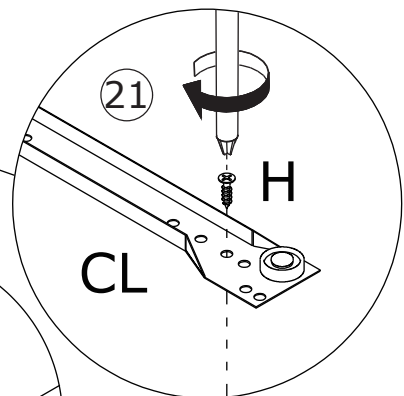
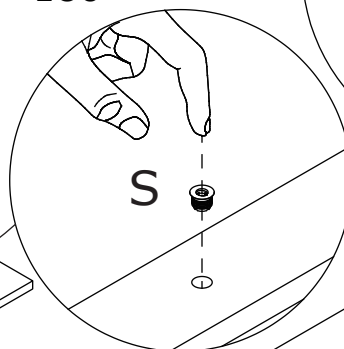

18

B x 18



S x 18

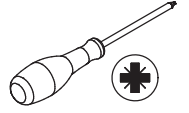

Screw eccentric rod(B) into board 16, 17, 18 and 19 at first.

Flip board 18 and 19 to back, screw eccentric rod(B) into as well.

Vissez d'abord la tige excentrique (B) dans les planches 16, 17, 18 et 19.

Retournez les planches 18 et 19 vers l'arrière, vissez également la tige excentrique (B).

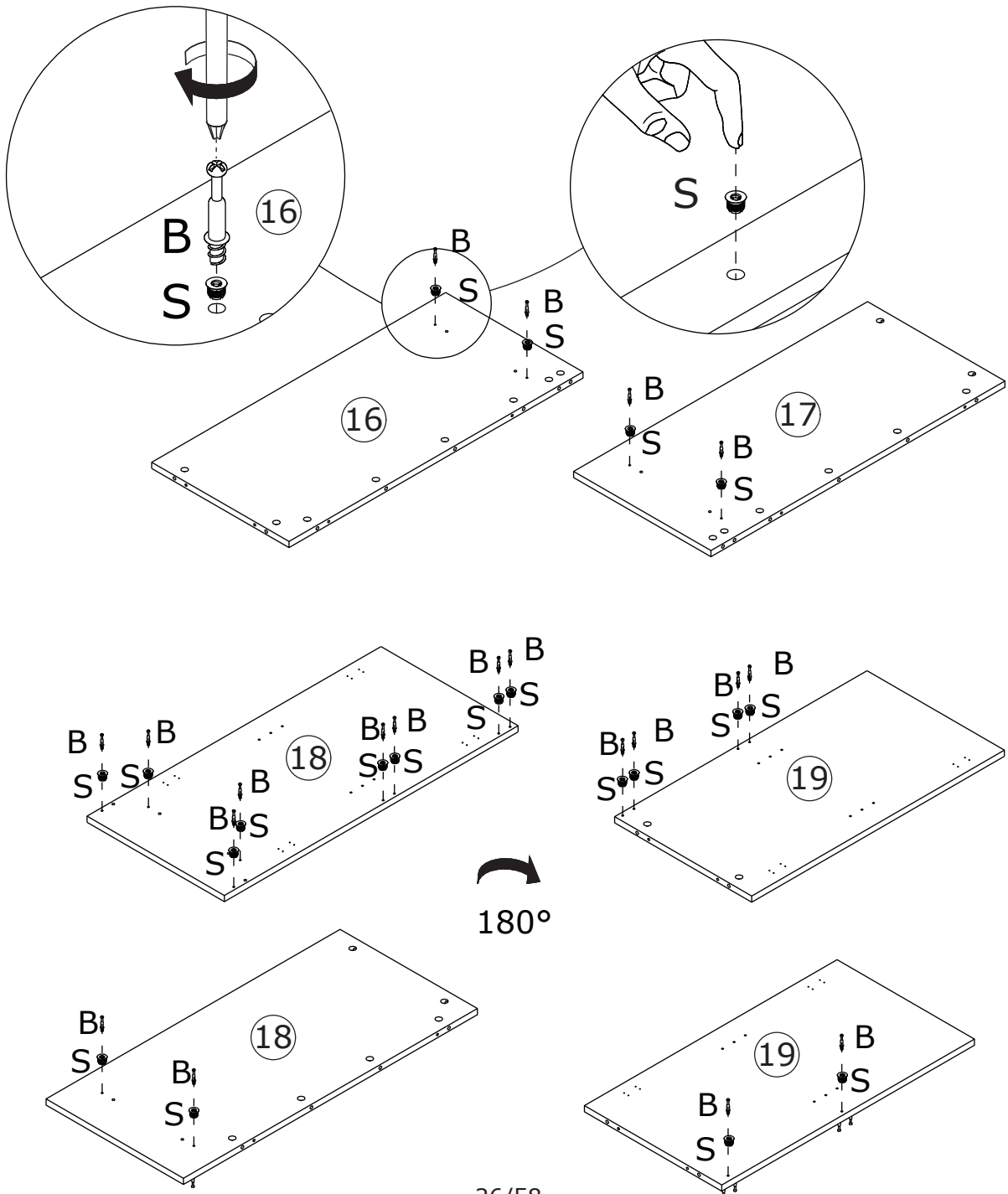
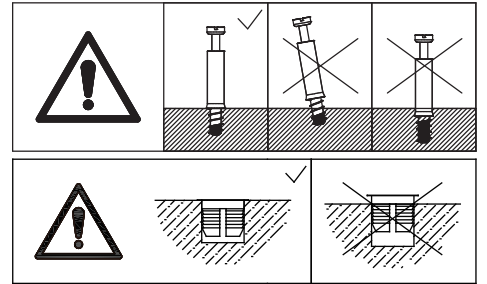

19

Connect board 20 and 19 to board 24 and 26 at first.

Connectez d'abord les planches 20 et 19 aux planches 24 et 26.

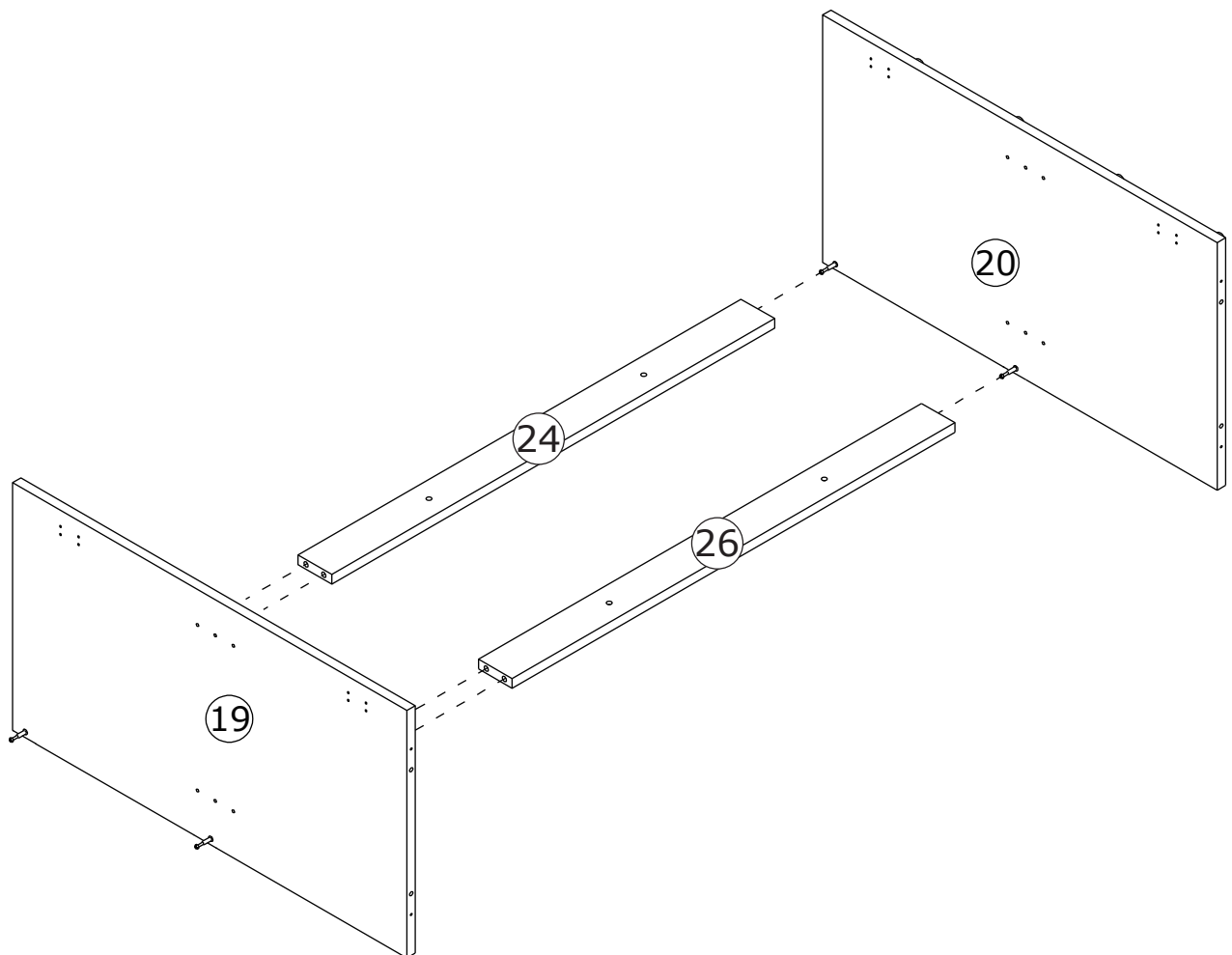

20

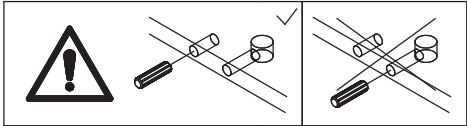
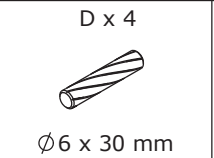
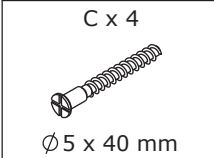

Attach board 19 and 20 to board 22 using wooden dowel(D), and fix with screw(C) as shown.

Fixez les planches 19 et 20 à la planche 22 à l'aide d'une cheville en bois (D) et fixez-les avec la vis (C) comme indiqué.

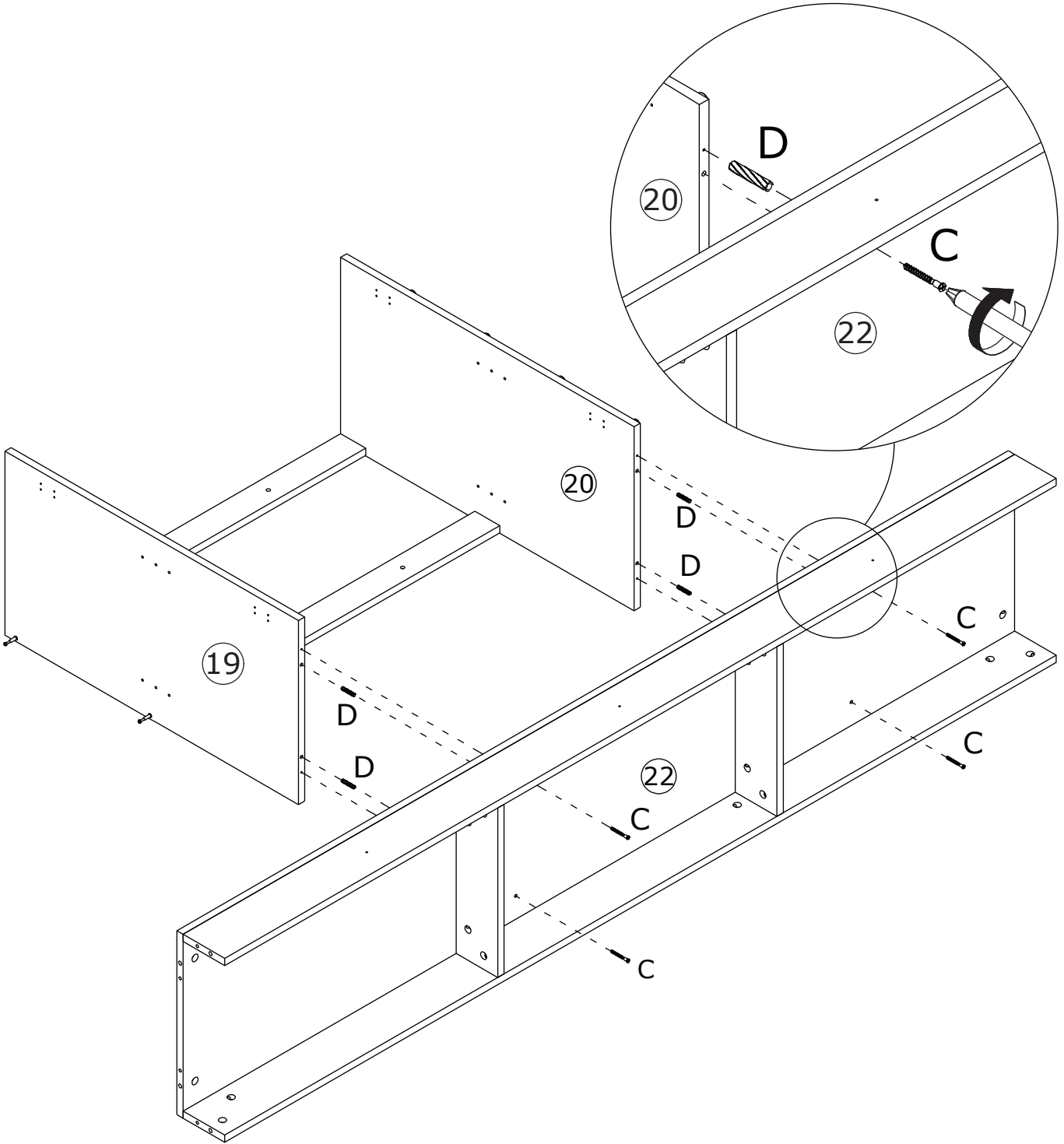

21

Connect board 24 and 26 to board 19,
board 25 and 27 to board 20 at first.

Connectez les cartes 24 et 26 à la carte 19 ;
connectez d'abord les cartes 25 et 27 à la carte 20.

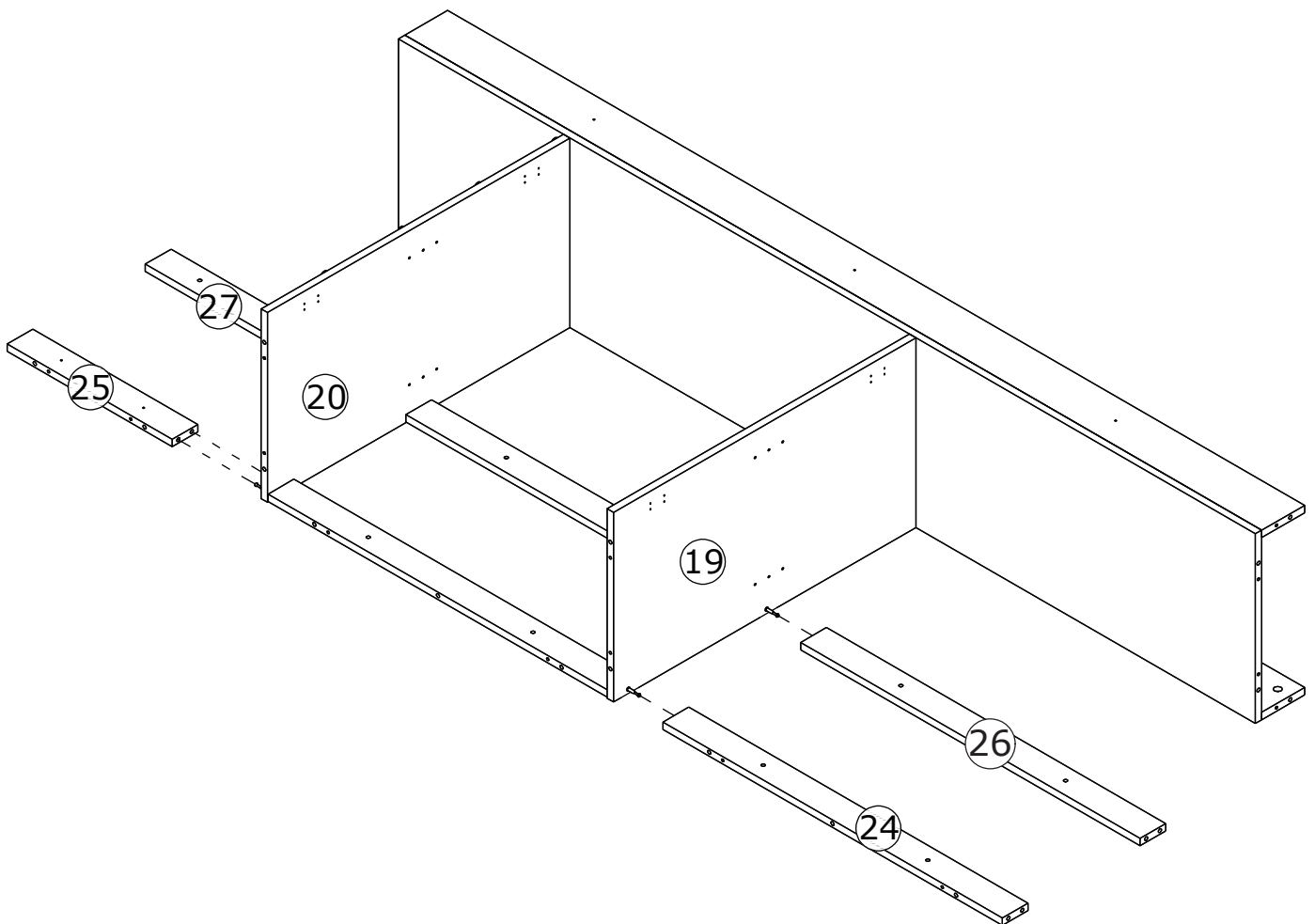

22

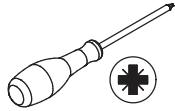
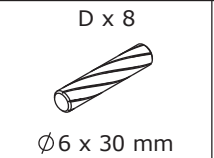
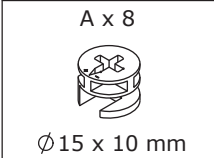

Connect board 18 and 21 to board 24, 26, 28, 22, 29, 25 and 27 using wooden dowel(D), add cam lock(A) into board 28, 22, 29 and turn clockwise to tighten as shown.

Connectez les planches 18 et 21 aux planches 24, 26, 28, 22, 29, 25 et 27 à l'aide de chevilles en bois (D), ajoutez un verrou à came (A) dans les planches 28, 22, 29 et tournez dans le sens des aiguilles d'une montre pour serrer comme indiqué.

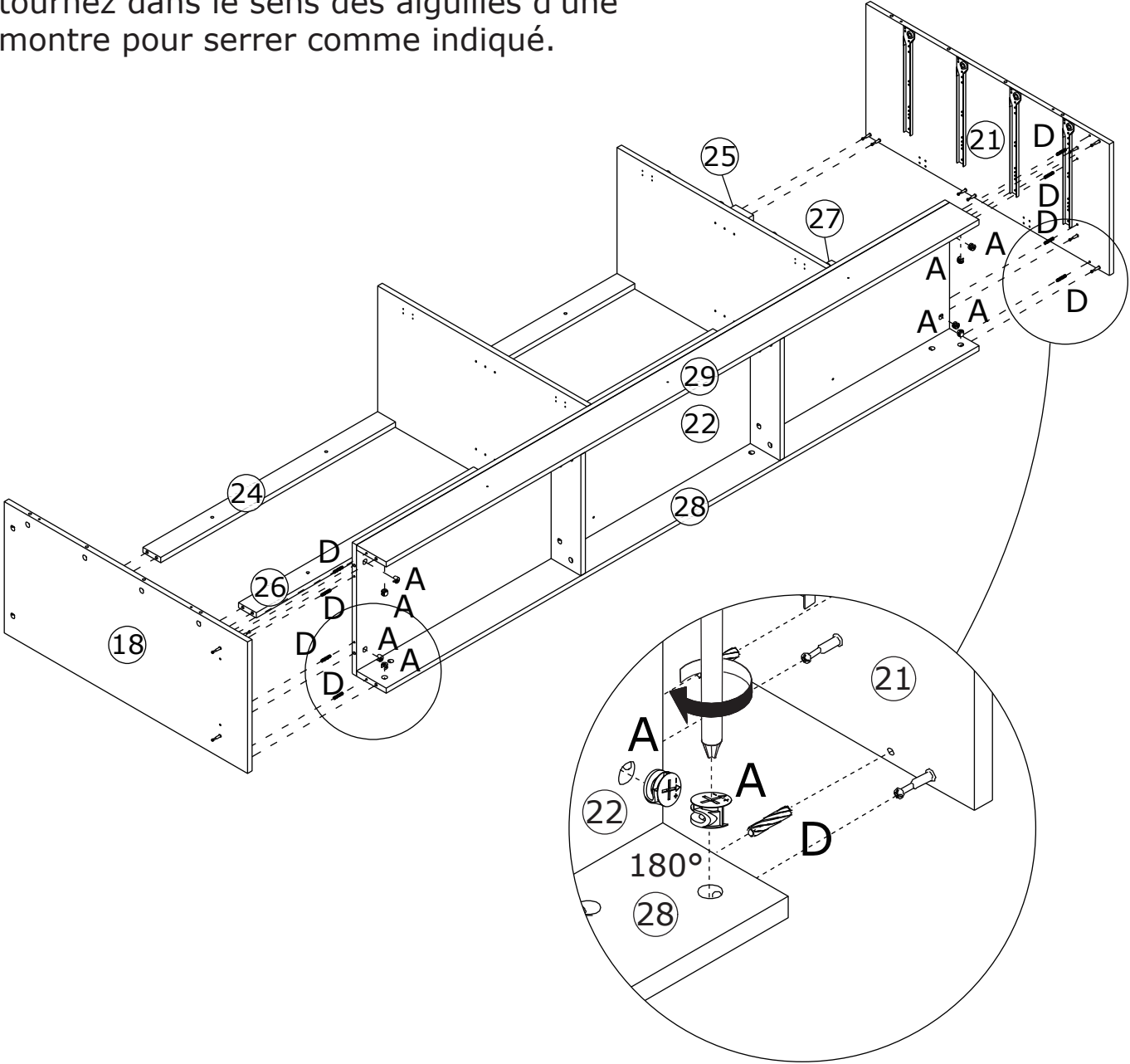
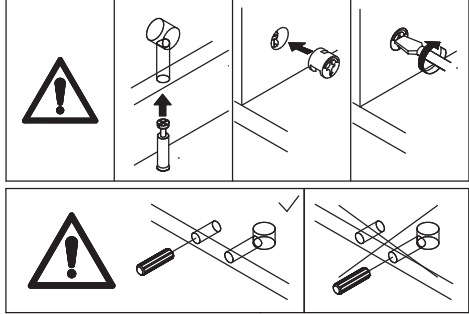

23



Attach board 23 to board 18 and 21 using wooden dowel(D), add cam lock(A) into board 23 and turn clockwise to tighten as shown.

Fixez la planche 23 aux planches 18 et 21 à l'aide de chevilles en bois (D), ajoutez un verrou à came (A) dans la planche 23 et tournez dans le sens des aiguilles d'une montre pour serrer comme indiqué.

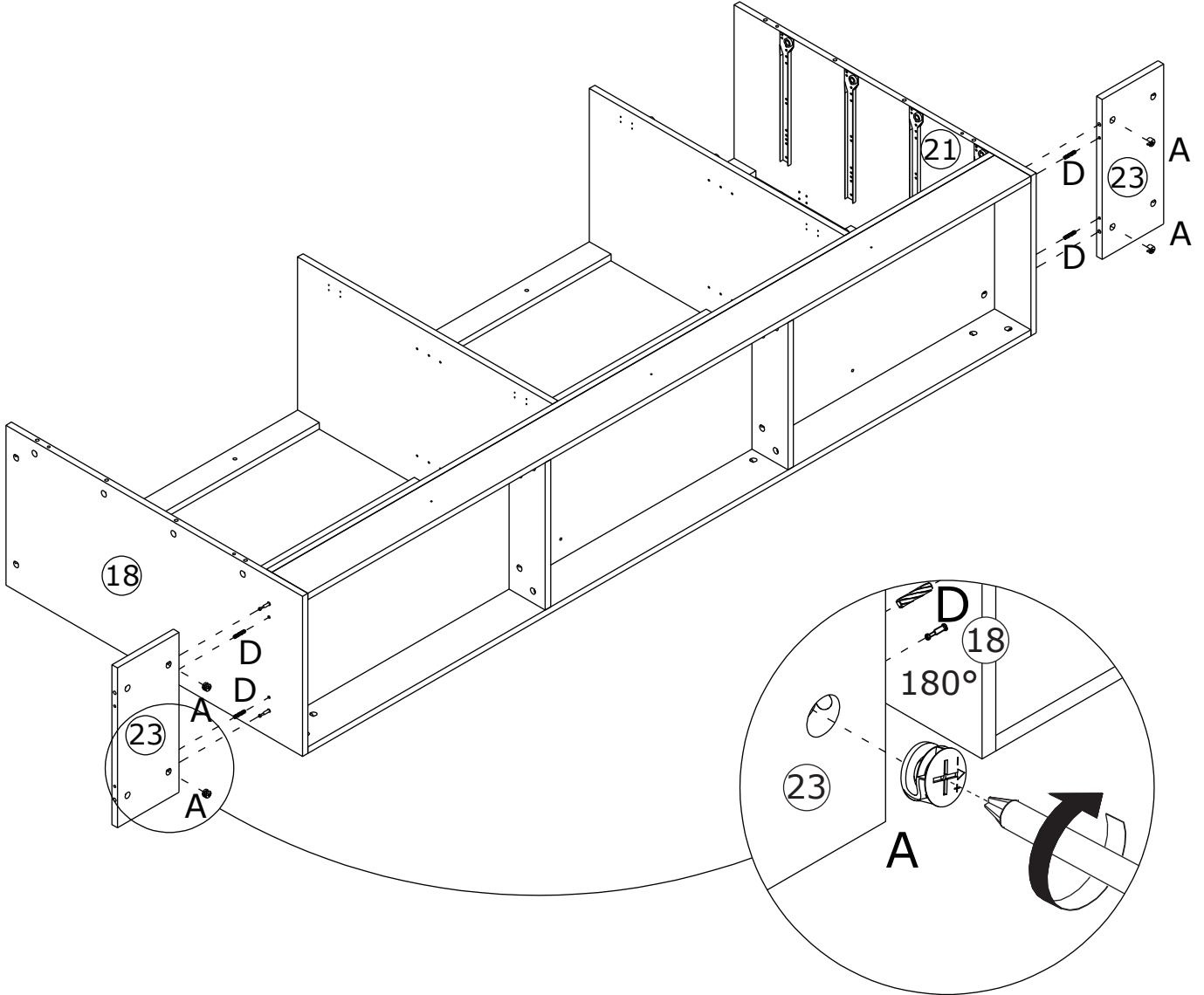
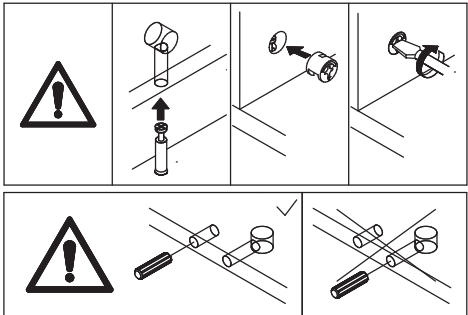

24

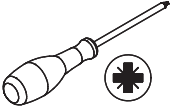
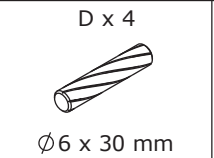
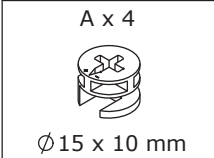

Attach board 16 and 17 to board 23 using wooden dowel(D), add cam lock(A) into board 23 and turn clockwise to tighten as shown.

Fixez les planches 16 et 17 à la planche 23 à l'aide de chevilles en bois (D), ajoutez un verrou à came (A) dans la planche 23 et tournez dans le sens des aiguilles d'une montre pour serrer comme indiqué.

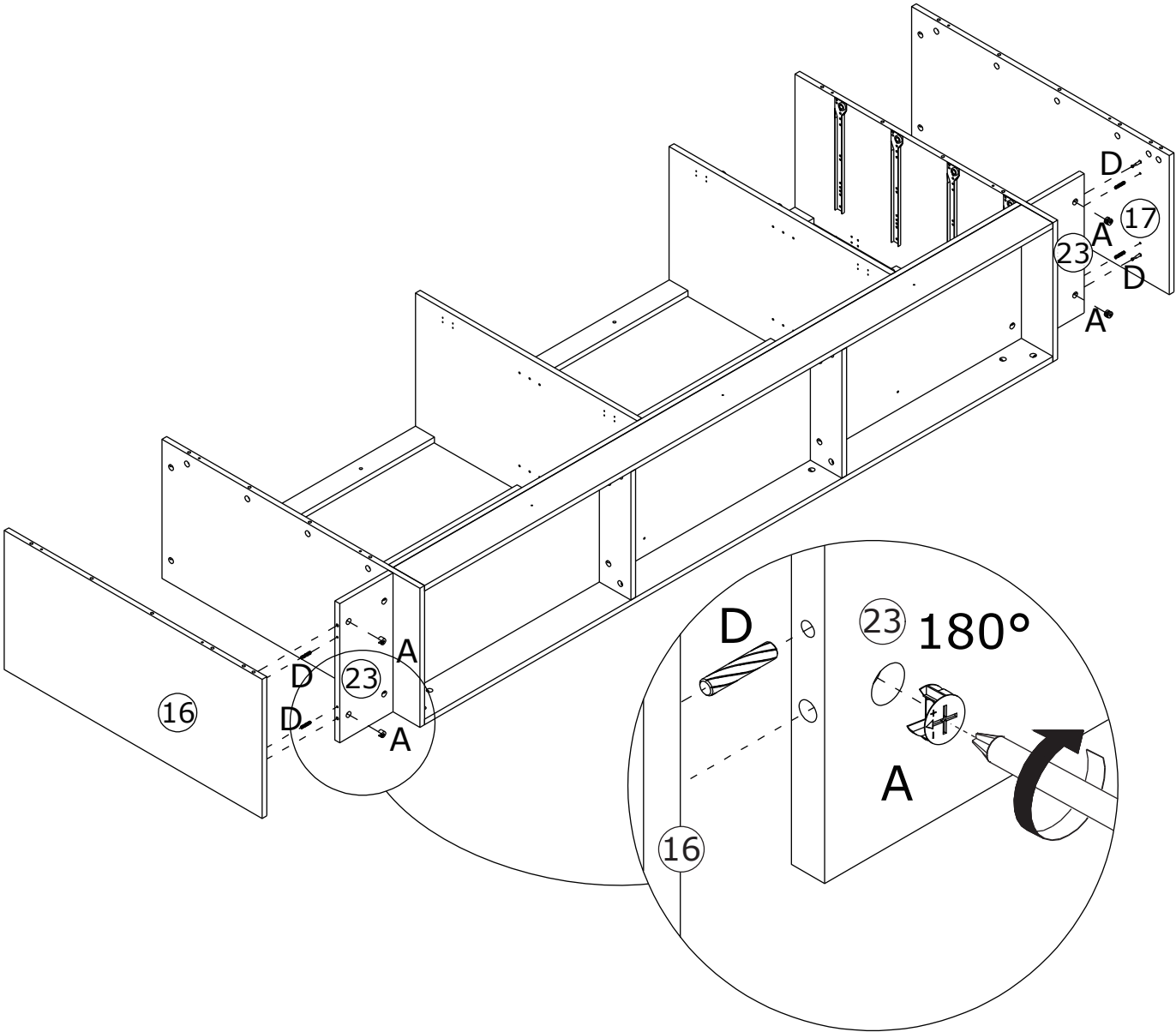
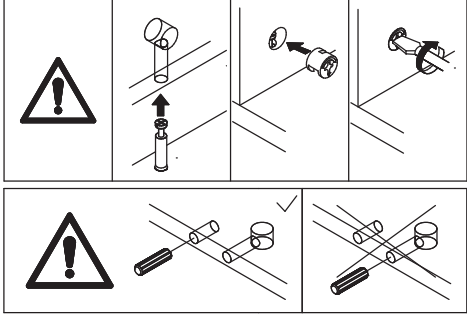

25

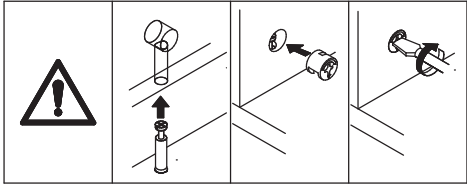
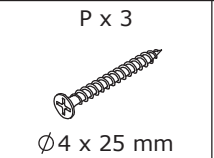
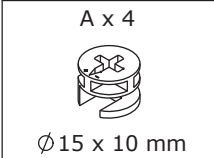

Attach board 31 to board 16 and 17, add cam lock(A) into board 16,17 and turn clockwise to tighten as shown.

Fix board 31 to board 28 using screw(P) as shown.

Fixez la planche 31 aux planches 16 et 17, insérez le verrou à came (A) dans les planches 16 et 17 et tournez dans le sens des aiguilles d'une montre pour serrer comme indiqué.

Fixez la planche 31 à la planche 28 à l'aide de la vis (P) comme indiqué.

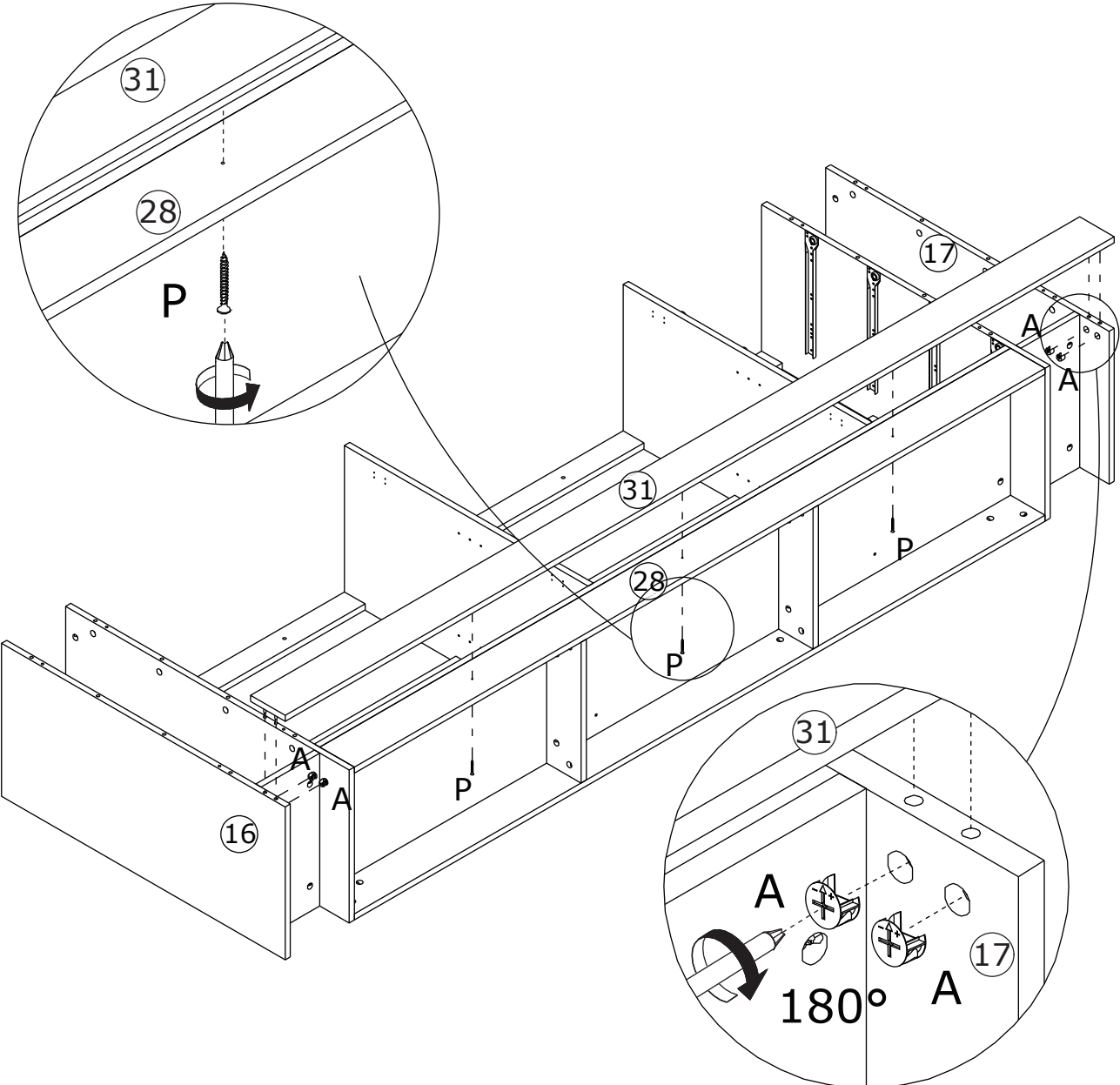

26

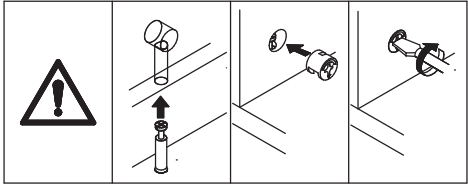
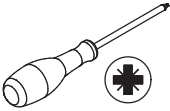
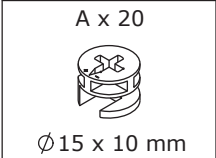

Add cam lock(A) into board 25, 24, 27, 26 and turn clockwise to tighten as shown.

Insérez le verrou à came (A) dans les planches 25, 24, 27 et 26 et tournez dans le sens des aiguilles d'une montre pour serrer comme indiqué.

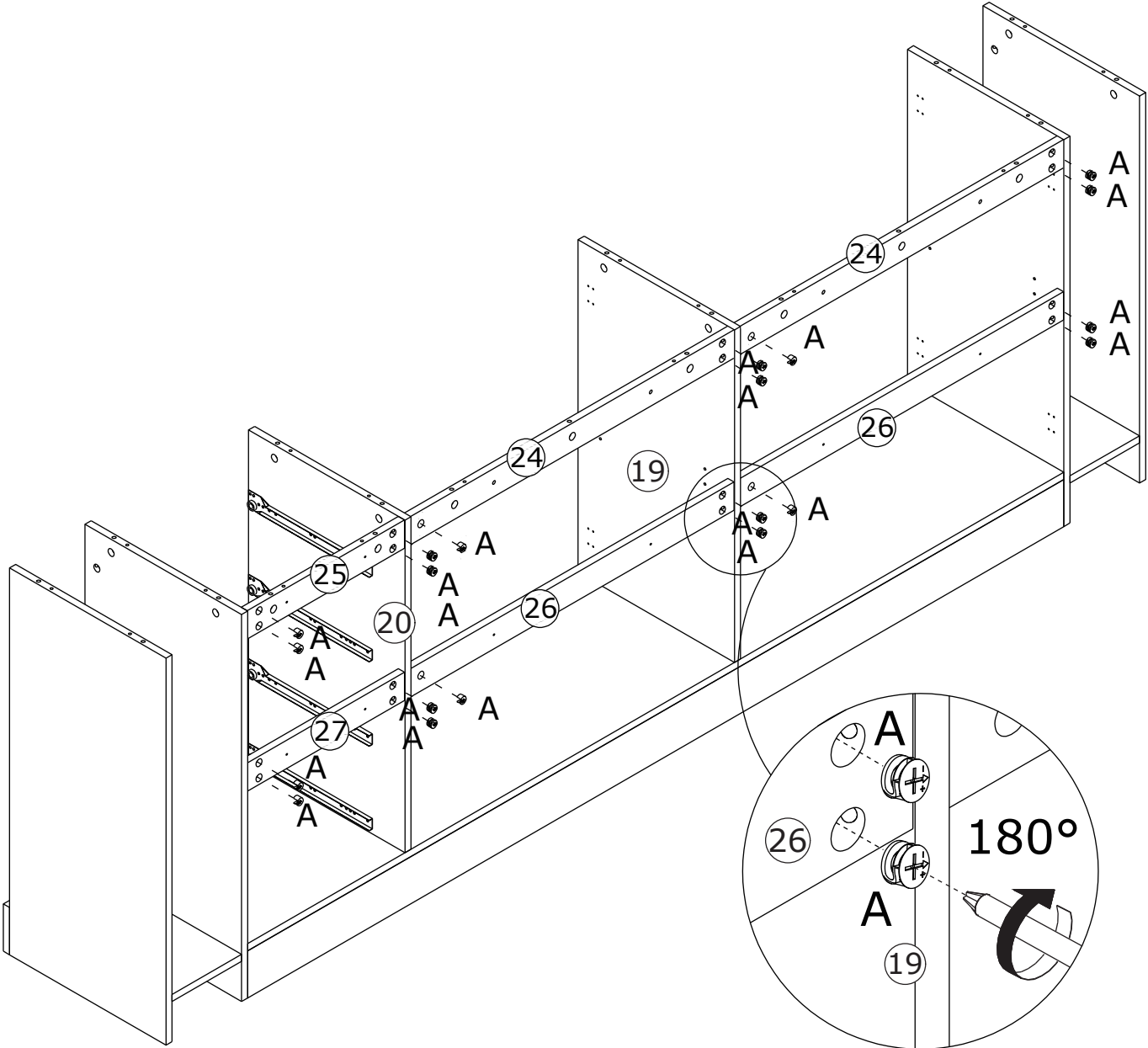

27

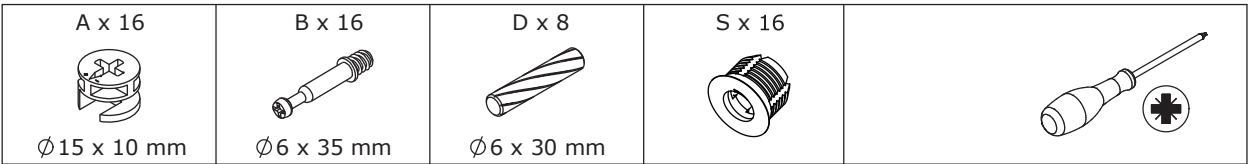

Screw eccentric rod(B) into board 32 at first. Attach board 32 to board 16, 18 and 21, 17 using wooden dowel(D), add cam lock(A) into and turn clockwise to tighten as shown.

Vissez d'abord la tige excentrique (B) dans la planche 32.
 Fixez la planche 32 aux planches 16, 18 et 21, 17 à l'aide d'un goujon en bois (D), ajoutez le verrou à came (A) et tournez dans le sens des aiguilles d'une montre pour serrer comme indiqué.

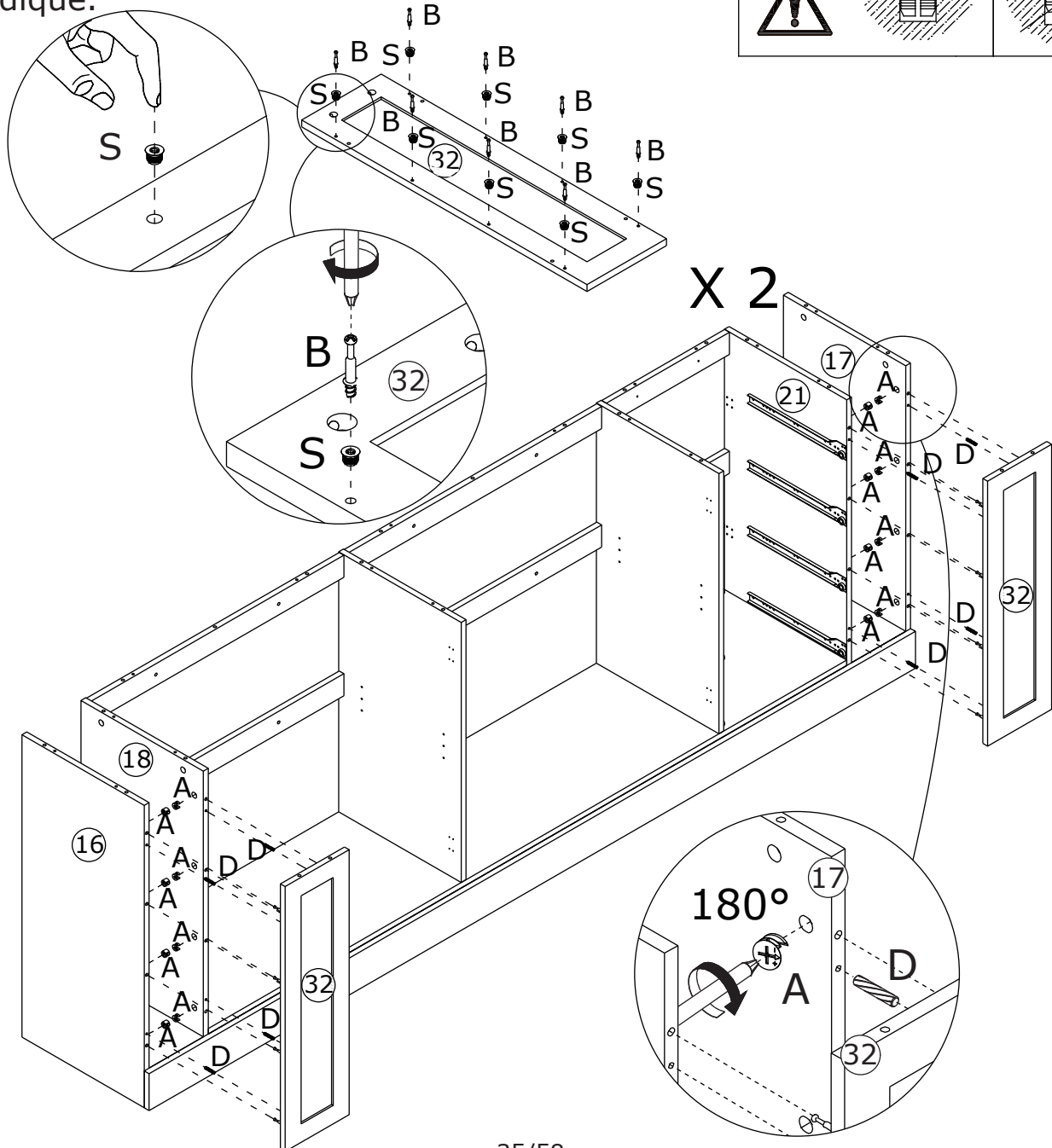
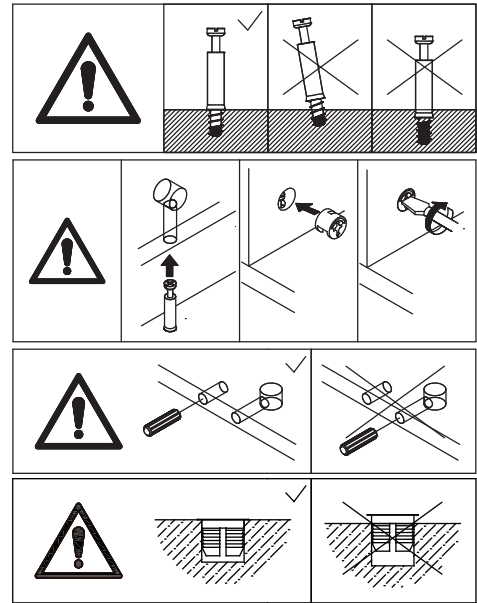

28

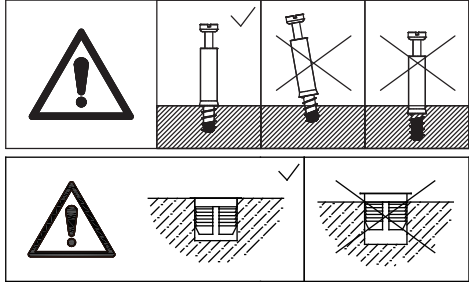
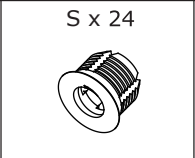
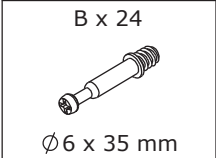

Screw eccentric rod(B) into board 15 at first.

Vissez d'abord la tige excentrique (B) dans la planche 15.

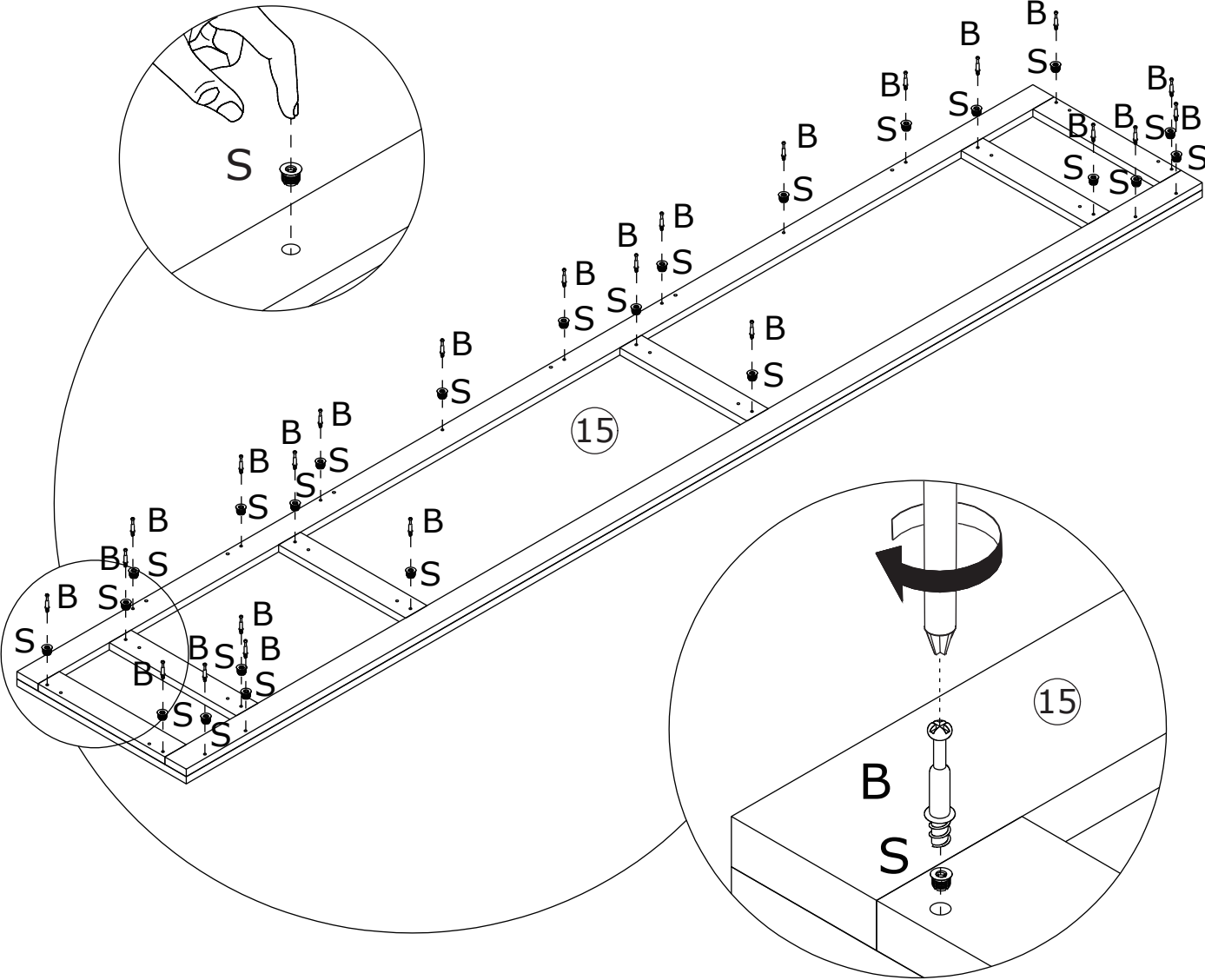

29



Attach board 15 to top using wooden dowel(D), add cam lock(A) into and turn clockwise to tighten as shown.

Fixez la planche 15 au sommet à l'aide d'un goujon en bois (D), ajoutez le verrou à came (A) et tournez dans le sens des aiguilles d'une montre pour serrer comme indiqué.

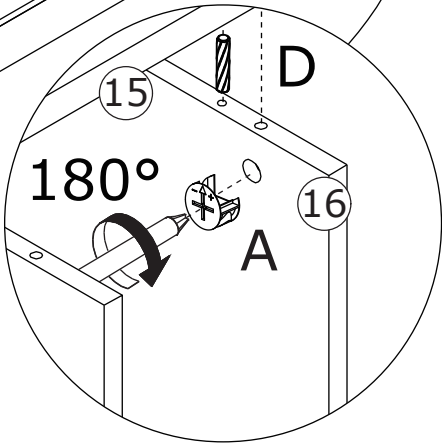
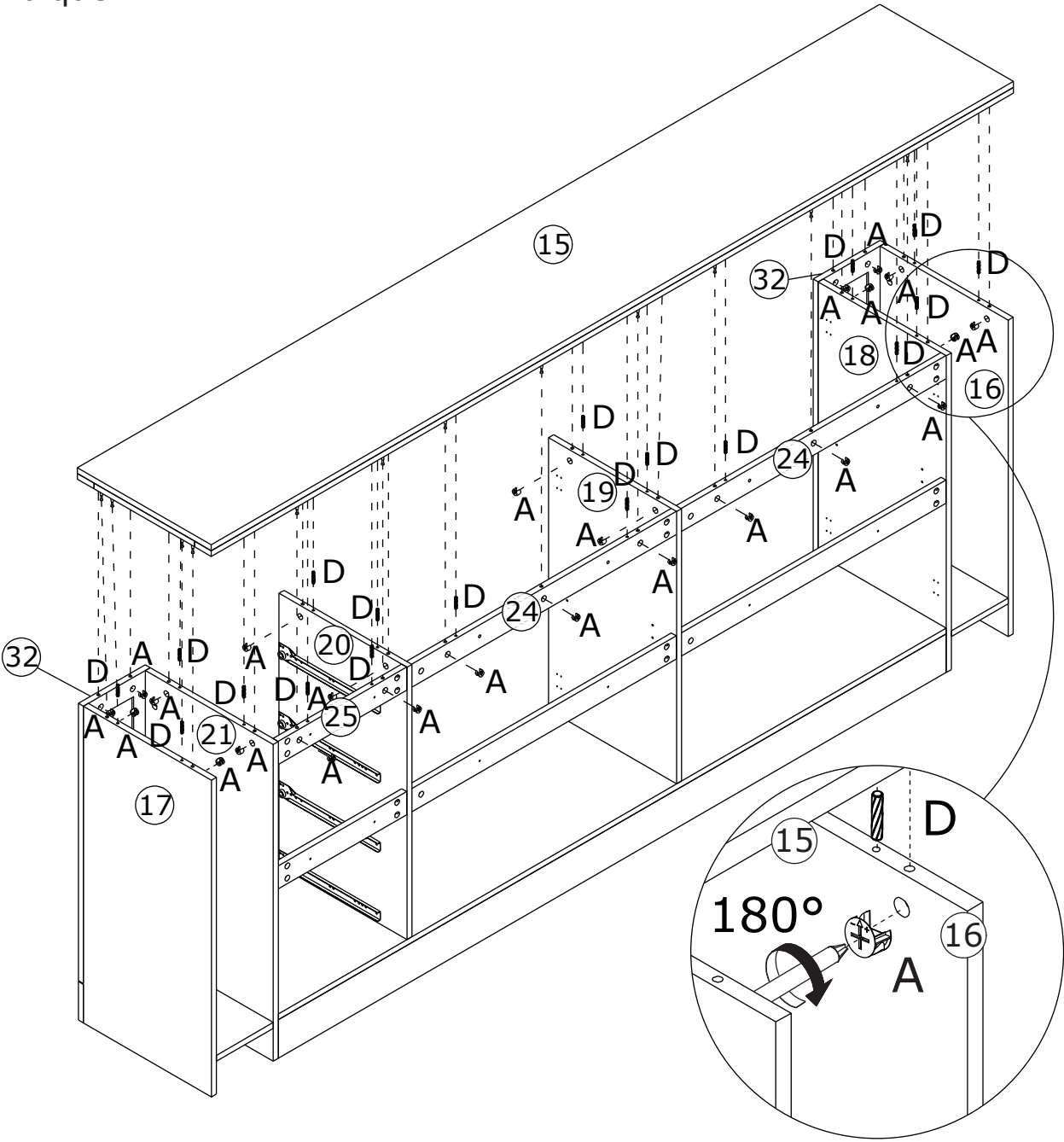
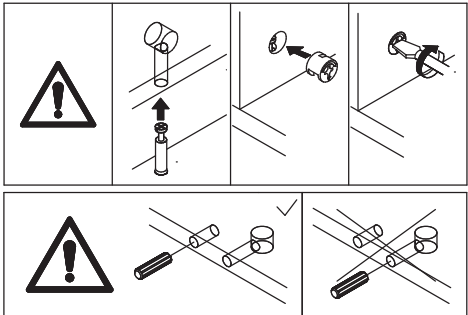

30

As shown in drawing.

Comme indiqué sur le dessin.

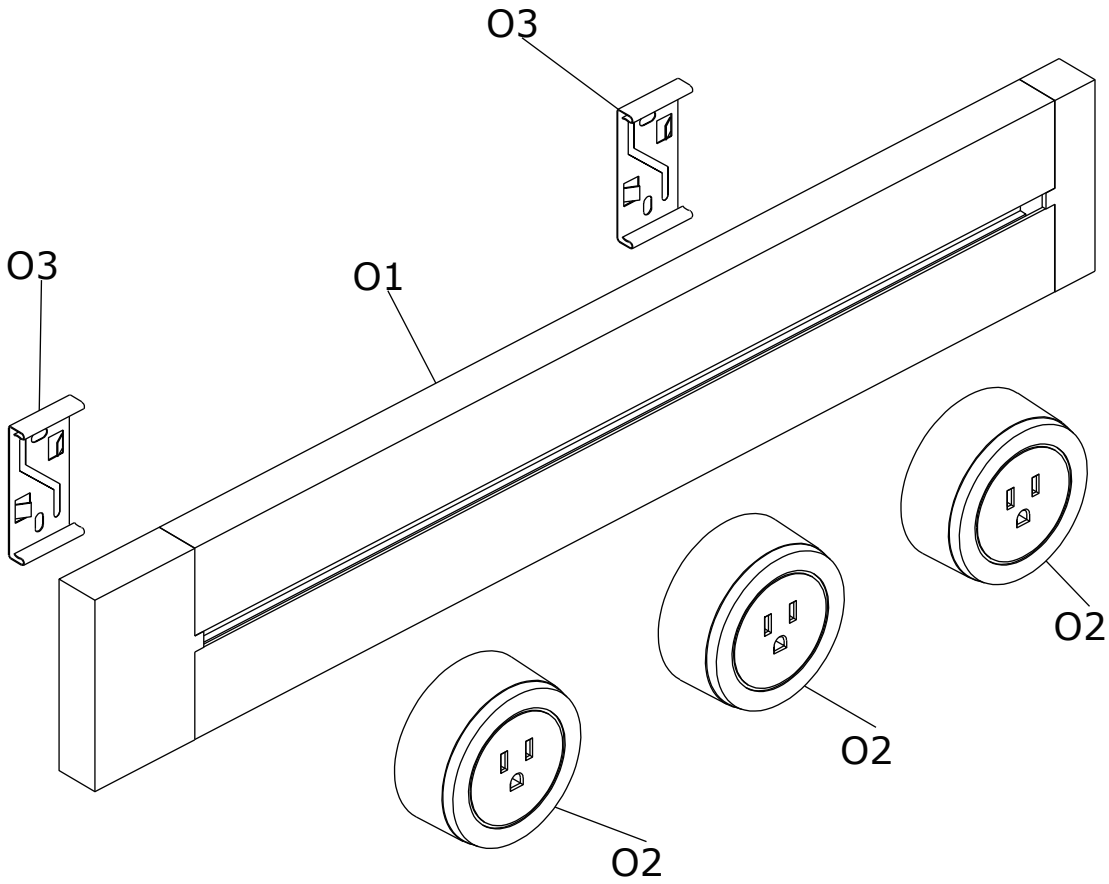

31

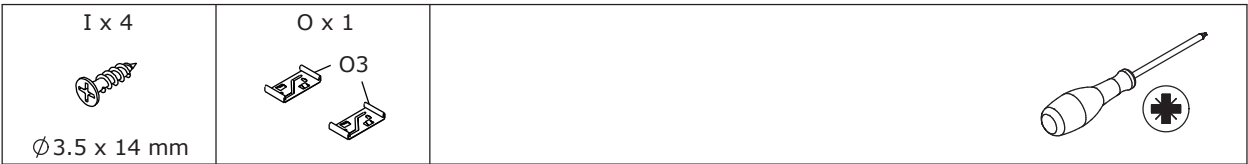

Fix part(O3) to board 7 with screw(I) as shown.

Fixez la pièce (O3) à la carte 7 à l'aide de la vis (I) comme indiqué.

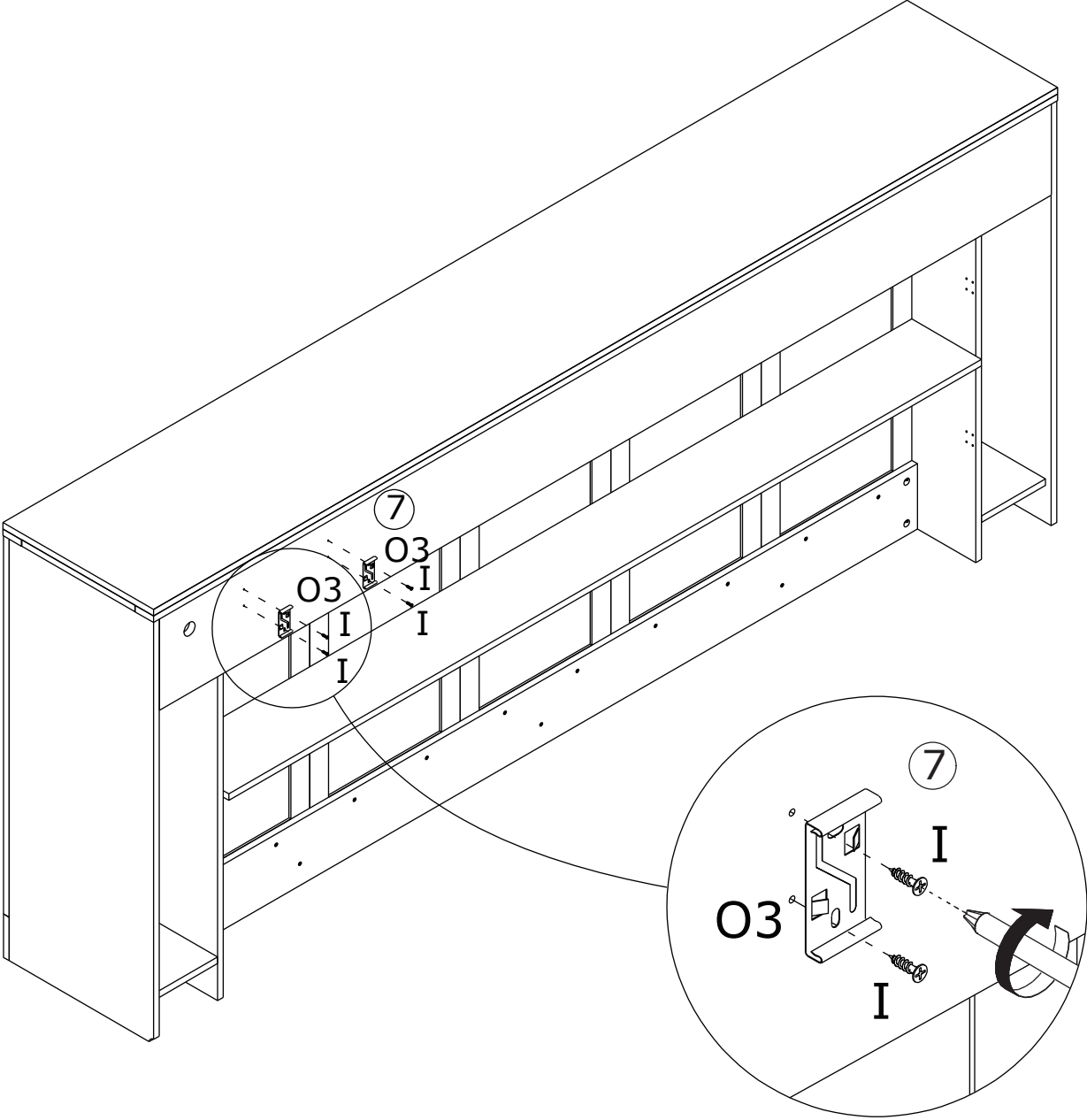

32

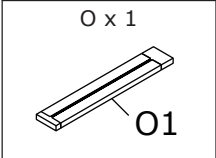

As shown in drawing.

Comme indiqué sur le dessin.

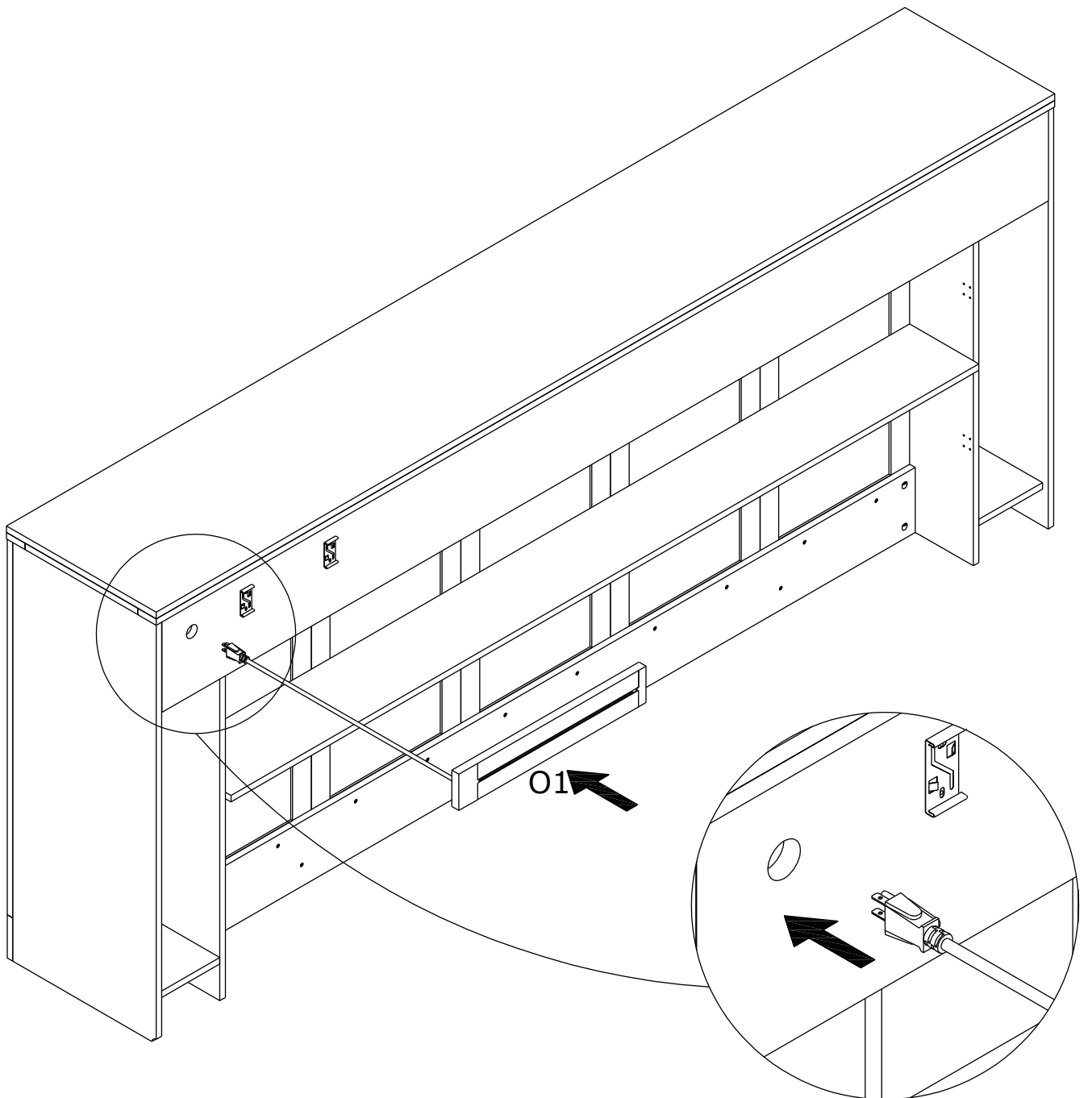

33

As shown in drawing.

Comme indiqué sur le dessin.

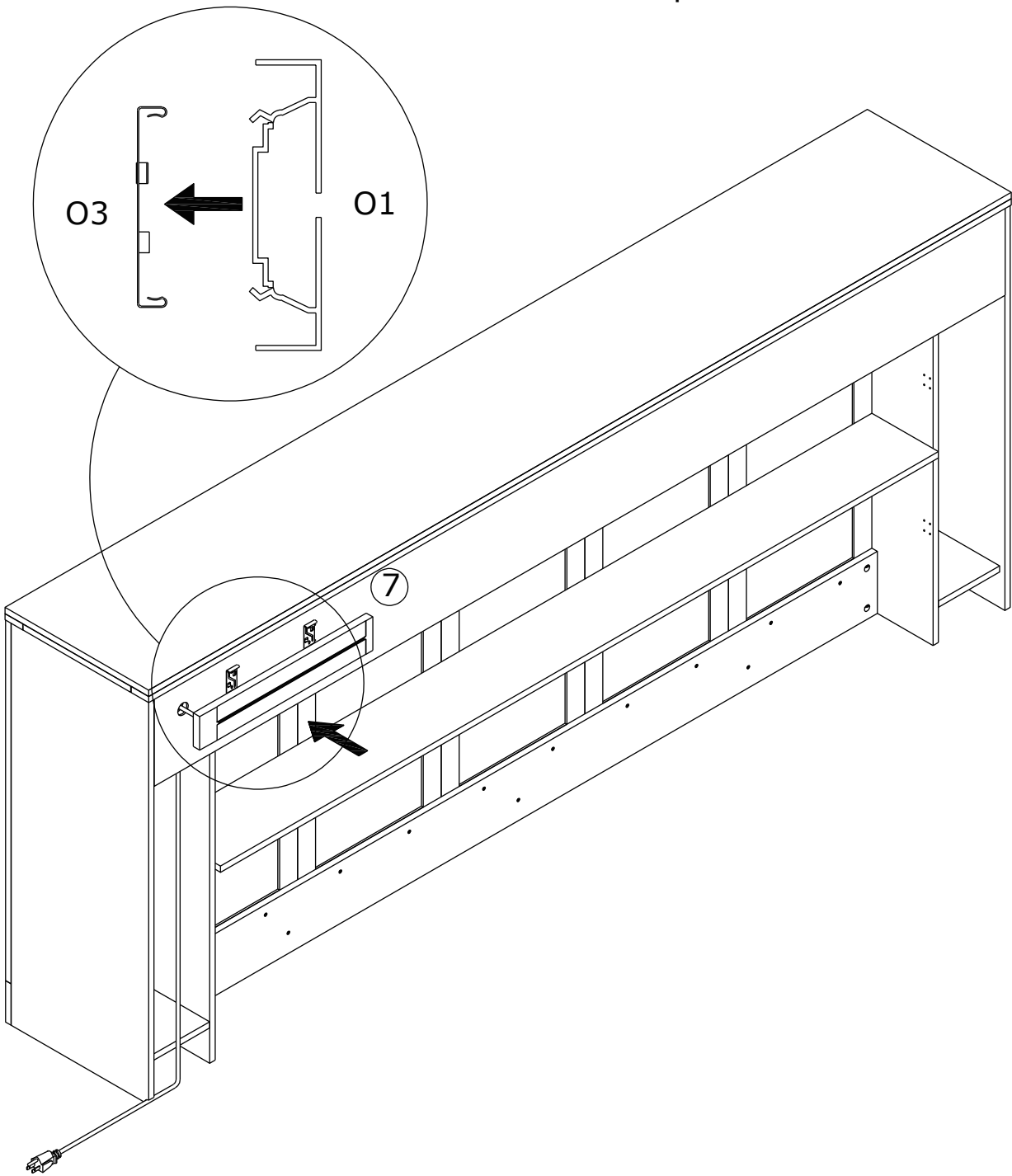

34

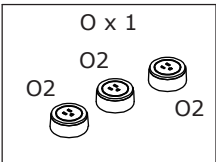

As shown in drawing.

Comme indiqué sur le dessin.

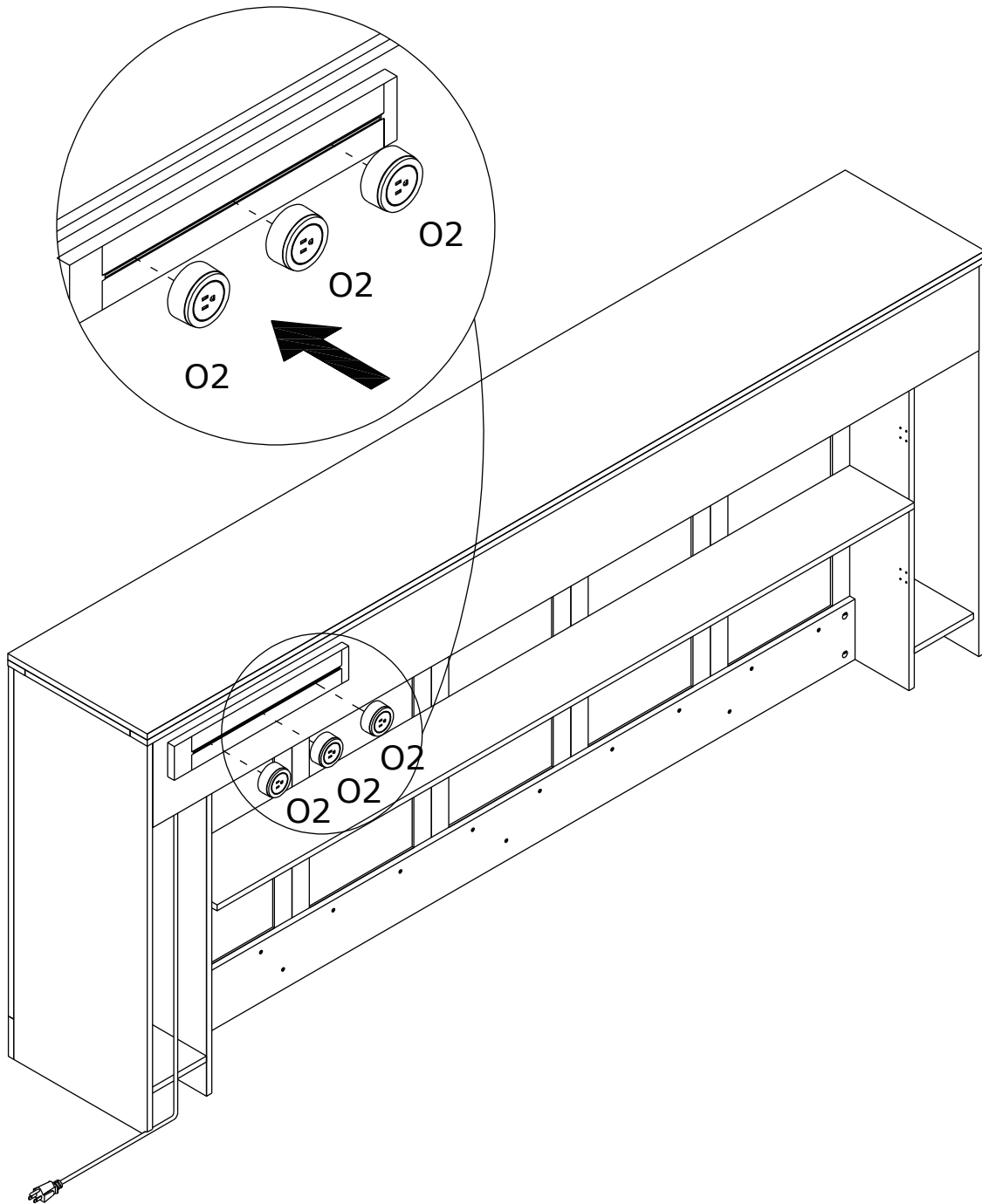
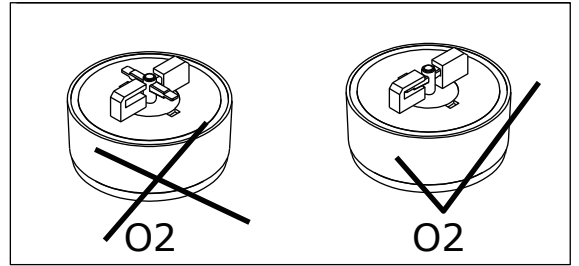

35

As shown in drawing.

Comme indiqué sur le dessin.

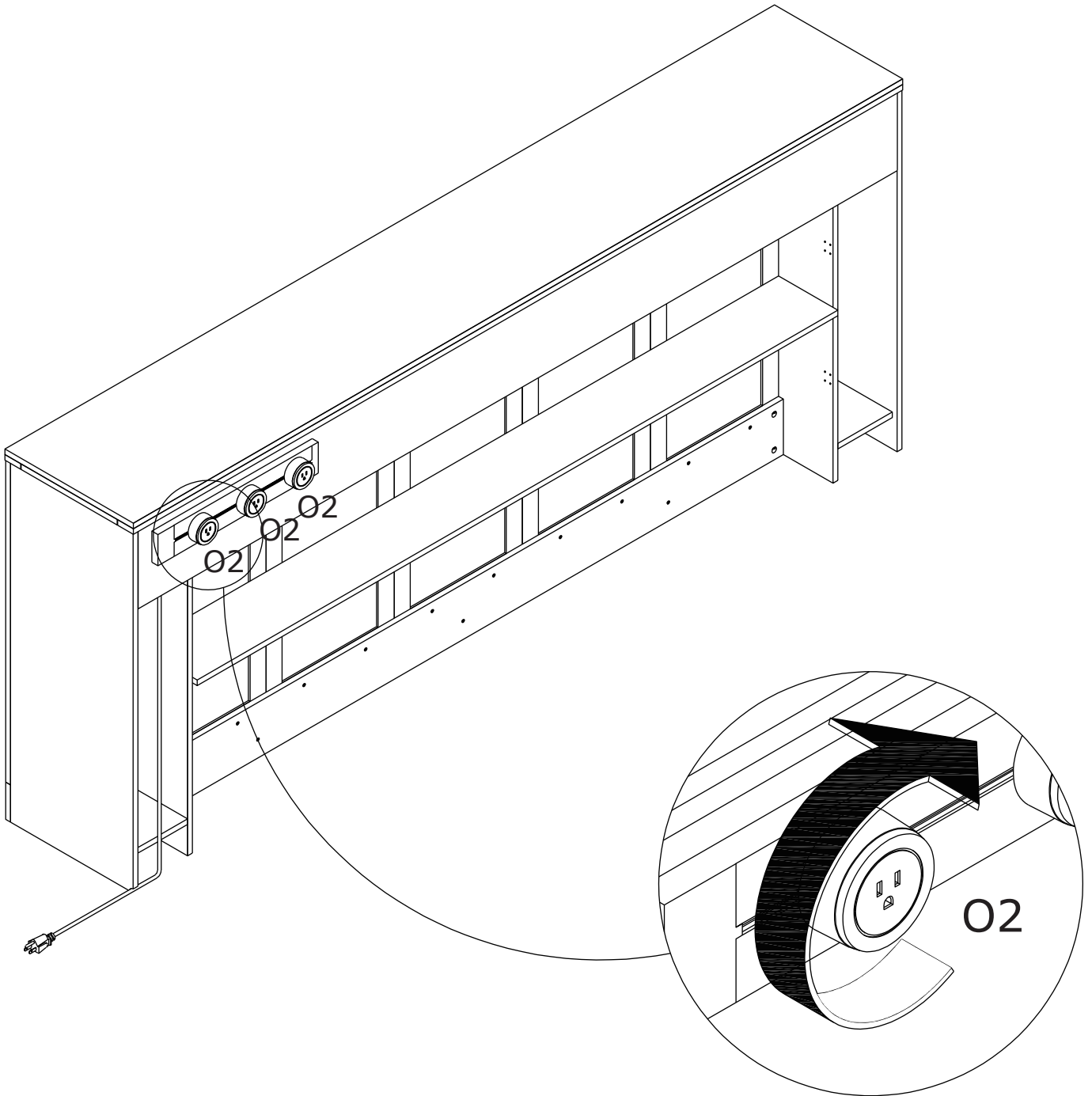

36

As shown in drawing.

Comme indiqué sur le dessin.

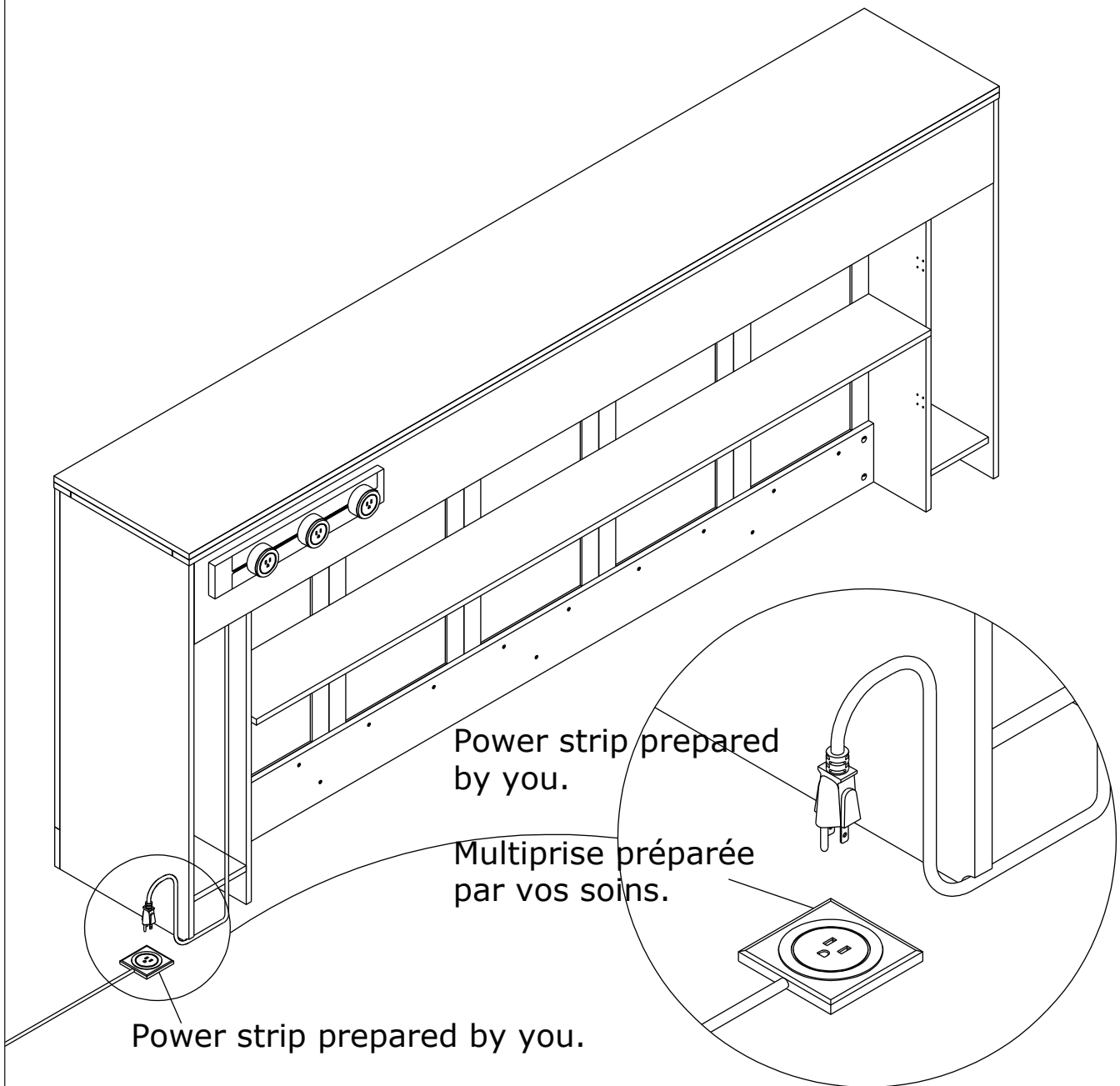

Power strip prepared by you.

Multiprise préparée par vos soins.

Power strip prepared by you.

Multiprise préparée par vos soins.

37

P x 12



Ø4 x 25 mm

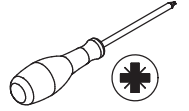

Fix the two components using screw(P) as shown.

Fixez les deux composants à l'aide de vis (P) comme indiqué.

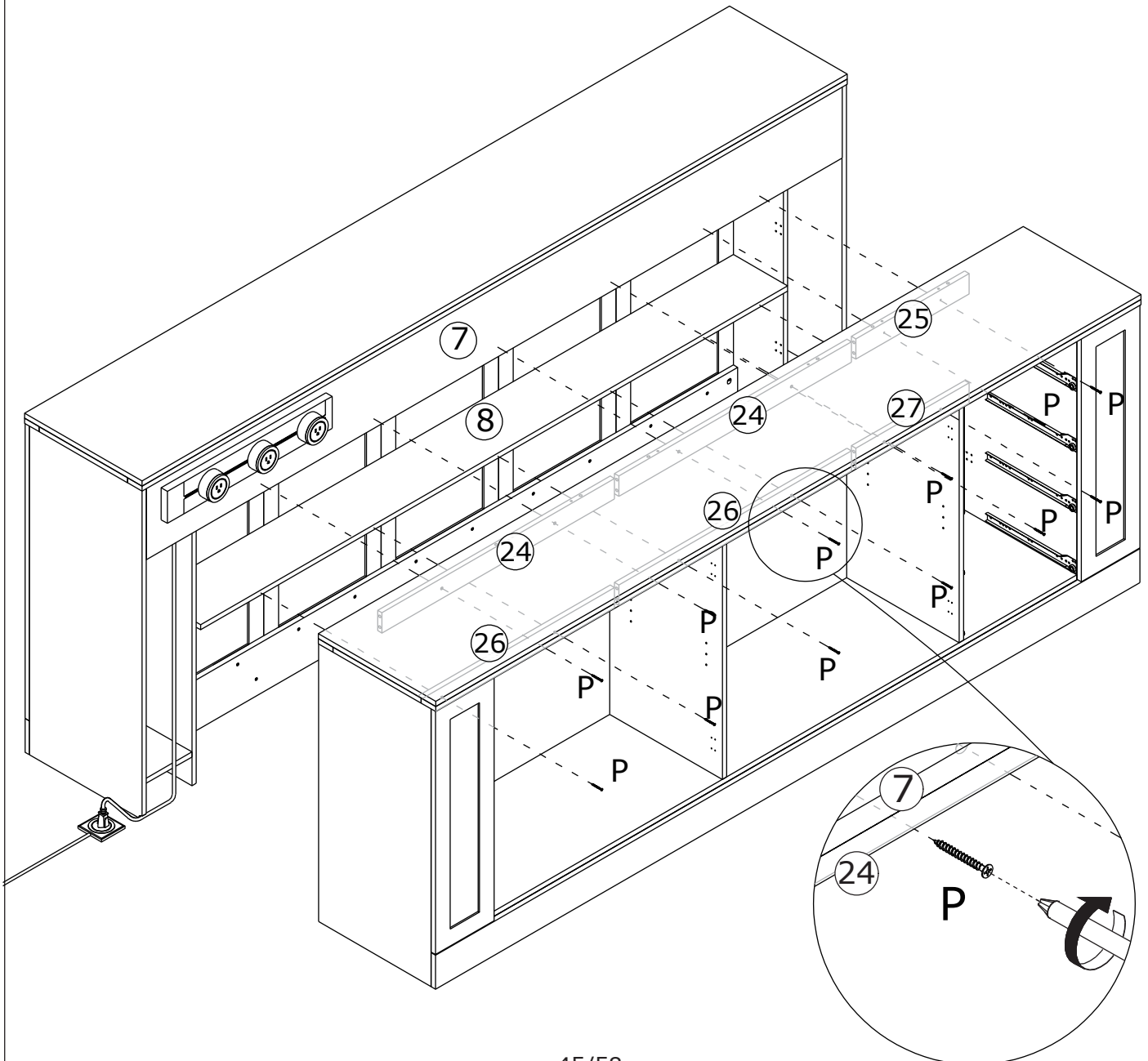

38

I x 32



Ø3.5 x 14 mm

Q x 4

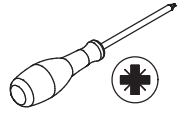
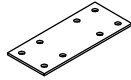

Fix metal plate(Q) to board 5, 18 and 4, 21 using screw(I) as shown.

Fixez la plaque métallique (Q) aux cartes 5, 18 et 4, 21 à l'aide de la vis (I) comme indiqué.

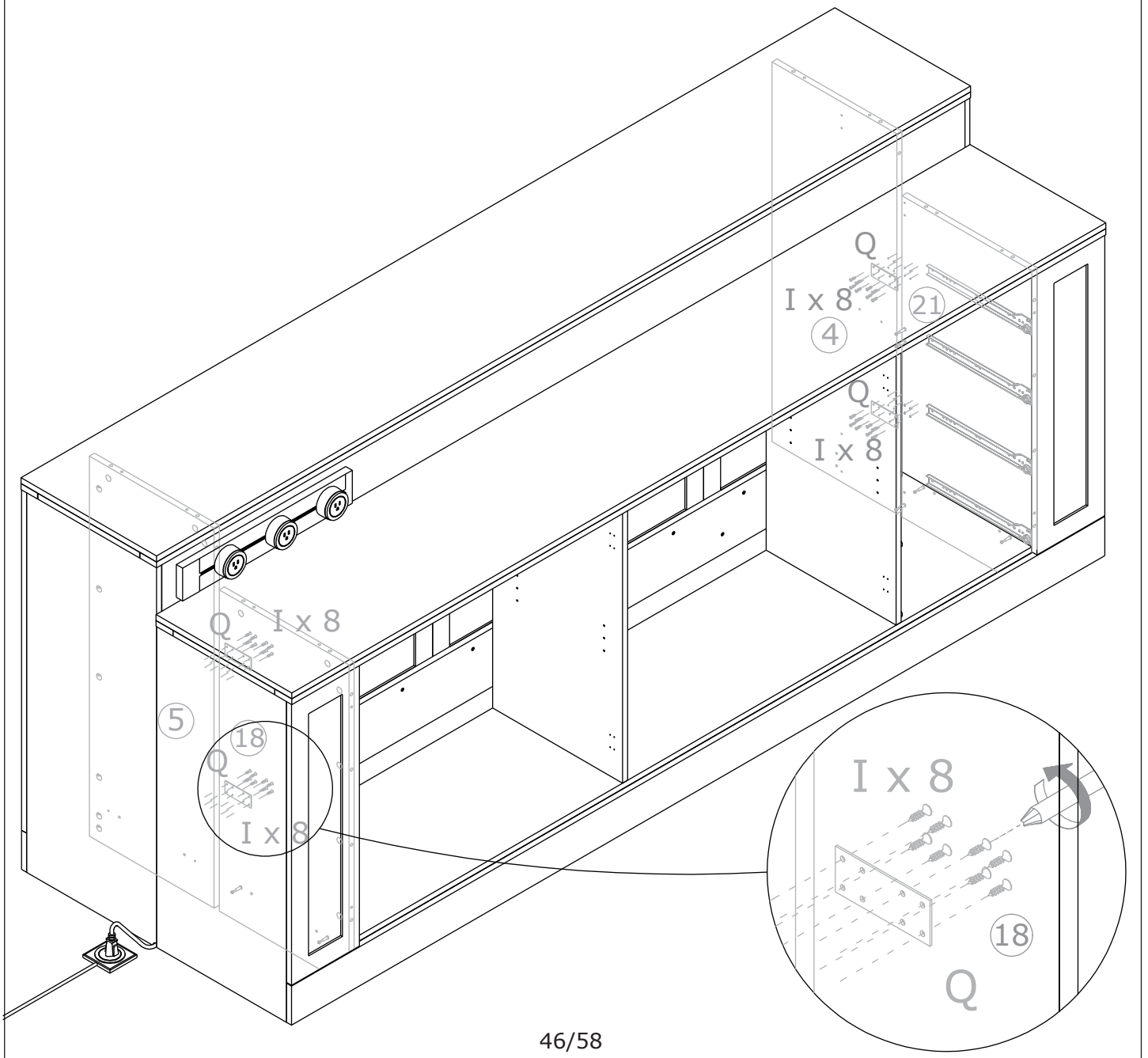

Pay attention to the difference between the middle parts of the two types of door hinges.





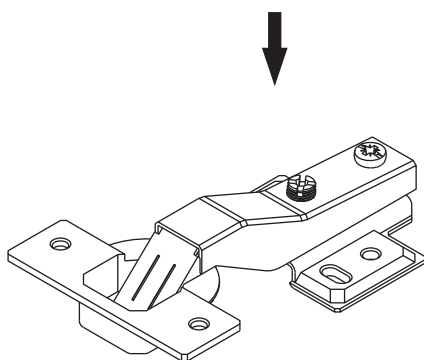
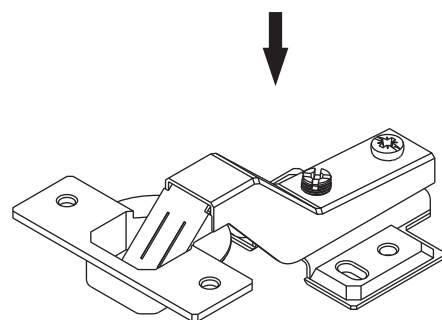

- The curved door hinges(F) are used on the outermost door plates.
- The curved door hinges(E) are used on the door panel in the middle of the cabinet.

Faites attention à la différence entre les parties centrales des deux types de charnières de porte.

- Les charnières de porte courbées (F) sont utilisées sur les plaques de porte les plus à l'extérieur.
- Les charnières de porte courbées (E) sont utilisées sur le panneau de porte au milieu de l'armoire.

**E****F**

40

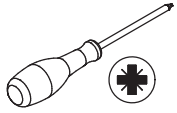
<p>F x 4</p> 	<p>I x 8</p>  <p>Ø3.5 x 14 mm</p>	<p>K x 2</p> 	<p>L x 4</p>  <p>Ø4 x 20 mm</p>	
--	--	--	---	---

Fix hinge(F) to board 33 and 36 with screw(I) as shown.
Fix handle(K) with screw(L) as shown.

Fixez la charnière (F) aux panneaux 33 et 36 à l'aide de la vis (I) comme indiqué.
Fixez la poignée (K) à l'aide de la vis (L) comme indiqué.

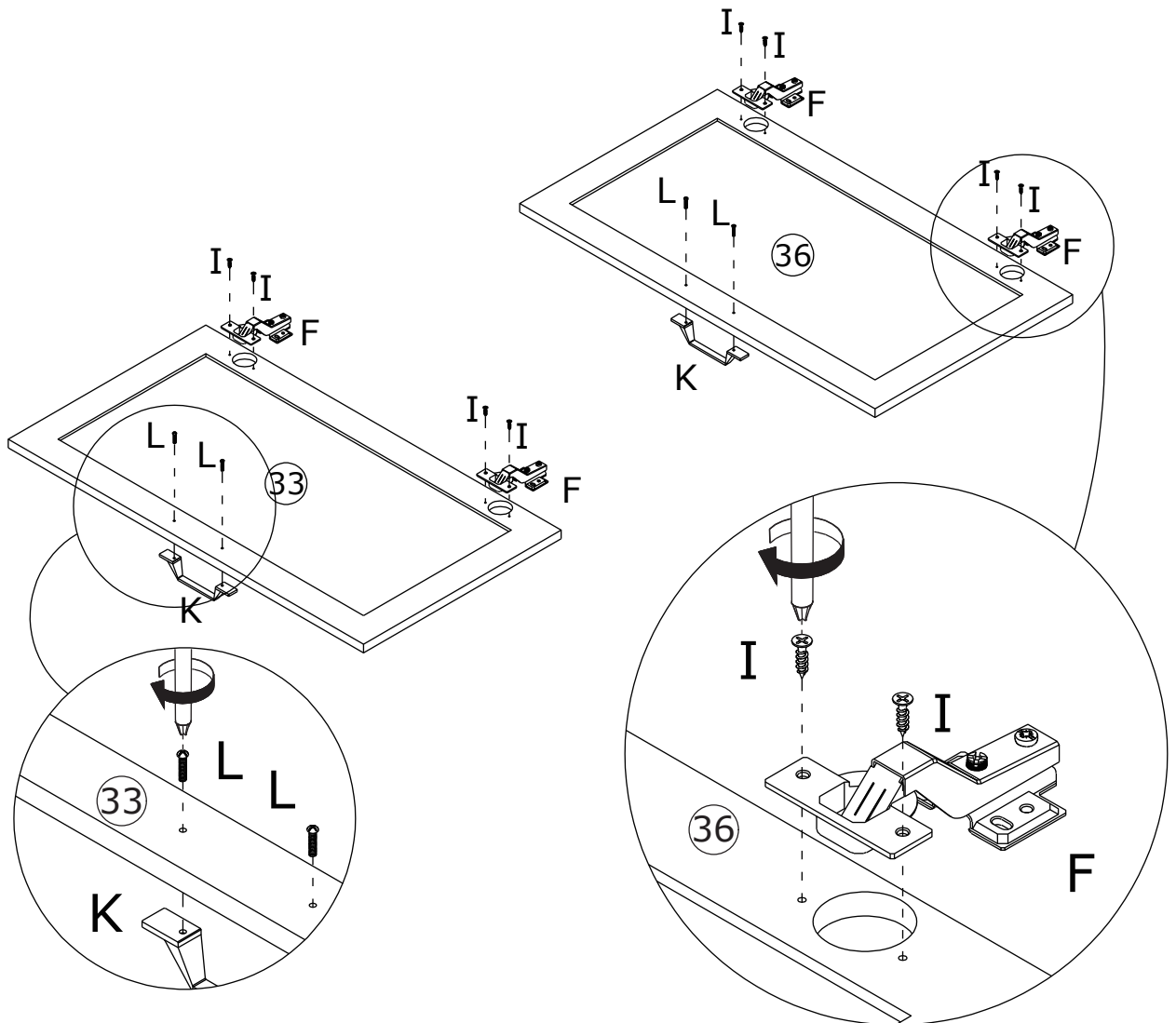

41

I x 16



Ø3.5 x 14 mm

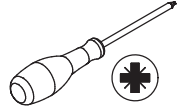



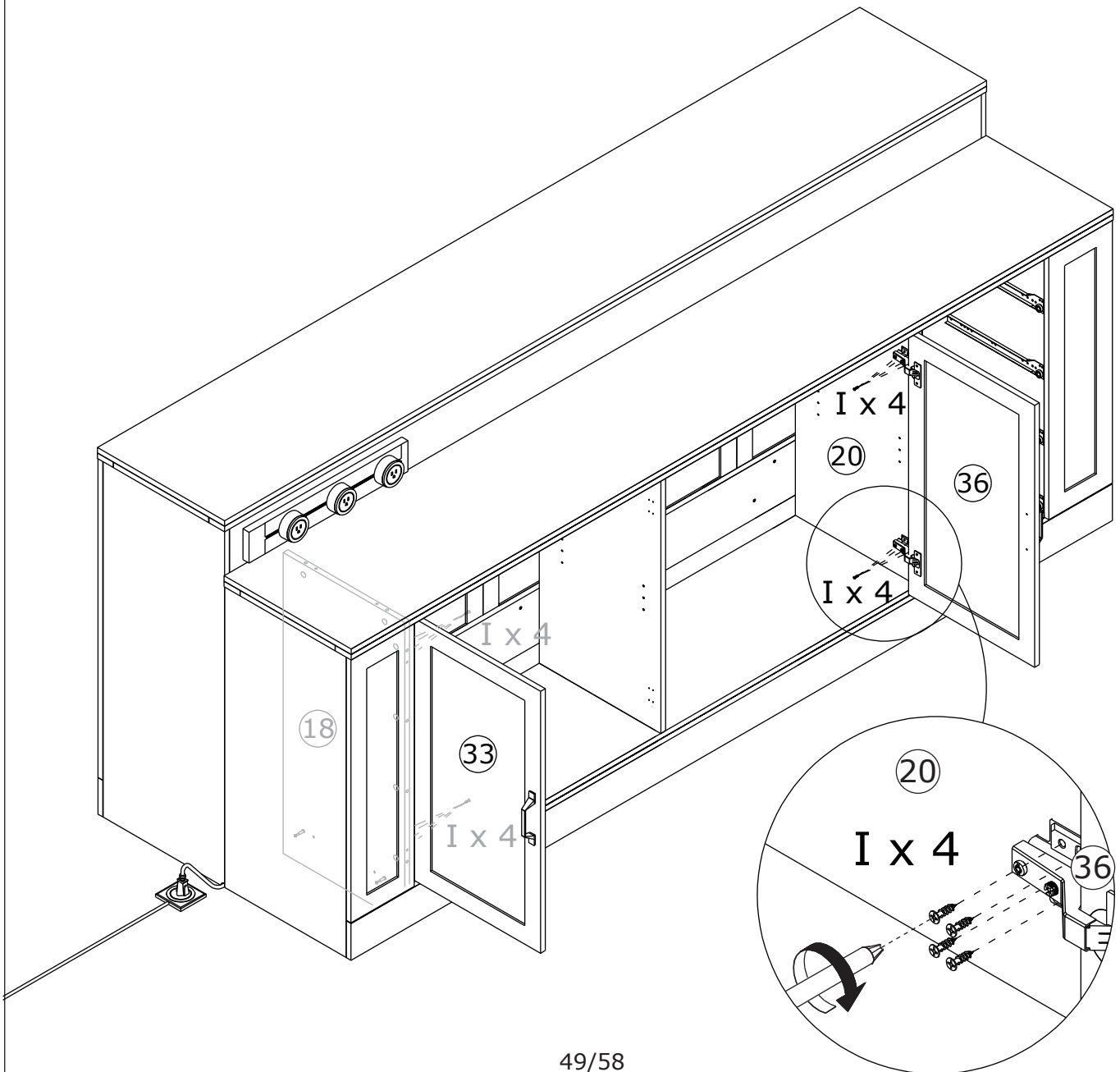

Assemble door 33 and 36 to board 18 and 20 by fixing hinge with screw(I) as shown.

Assemblez les portes 33 et 36 aux panneaux 18 et 20 en fixant la charnière à l'aide de la vis (I) comme indiqué.

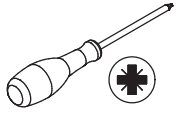

42

<p>E x 4</p> 	<p>I x 8</p>  <p>Ø3.5 x 14 mm</p>	<p>K x 2</p> 	<p>L x 4</p>  <p>Ø4 x 20 mm</p>	
--	--	--	---	---

Fix hinge(E) to board 34 and 35 with screw(I) as shown.
Fix handle(K) with screw(L) as shown.

Fixez la charnière (E) aux panneaux 34 et 35 à l'aide de la vis (I) comme indiqué.
Fixez la poignée (K) à l'aide de la vis (L) comme indiqué.

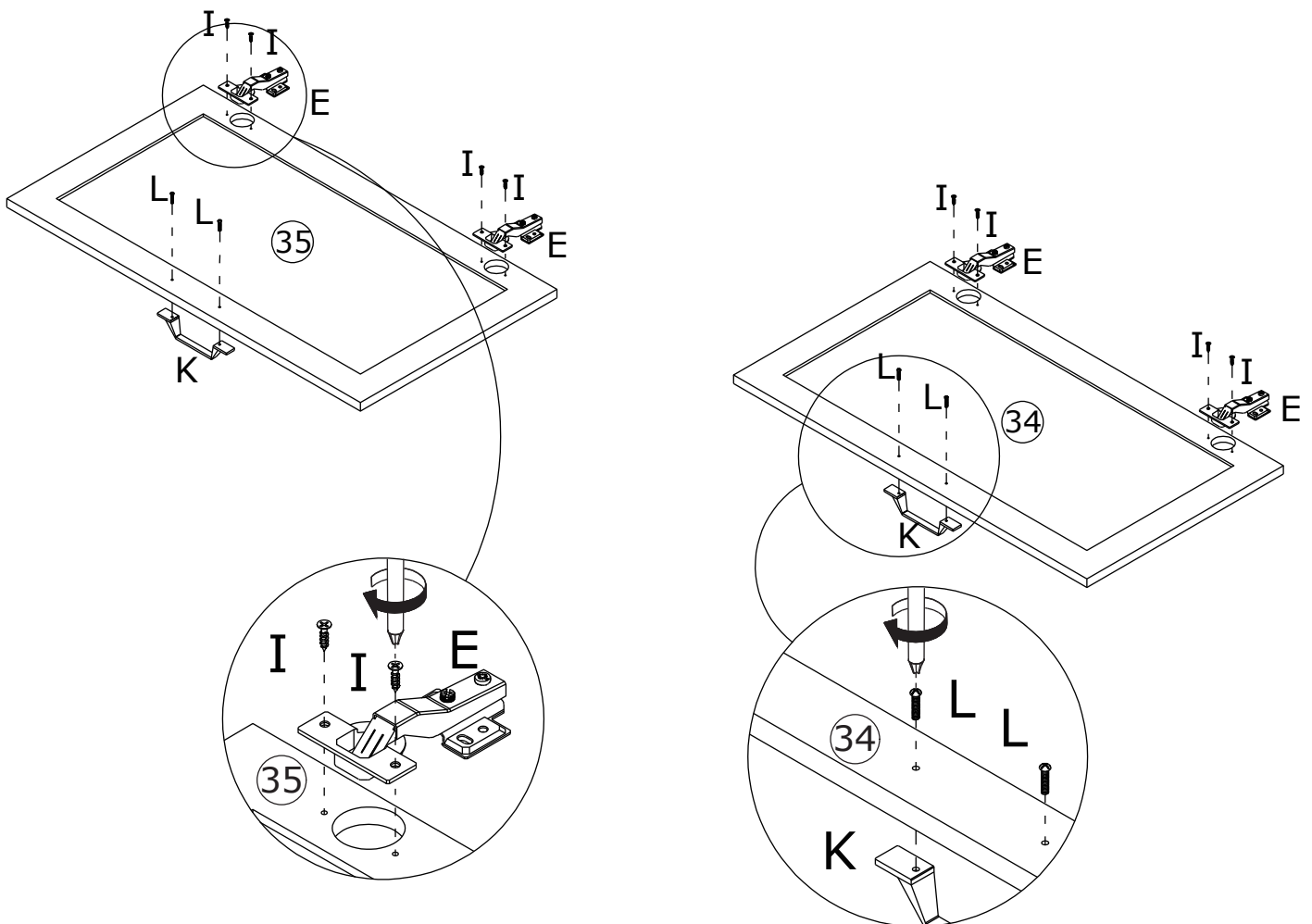

43

I x 16



Ø3.5 x 14 mm

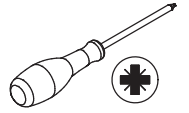

Assemble door 34 and 35 to board 19 by fixing hinge with screw(I) as shown.

Assemblez les portes 34 et 35 à la planche 19 en fixant la charnière à l'aide de la vis (I) comme indiqué.

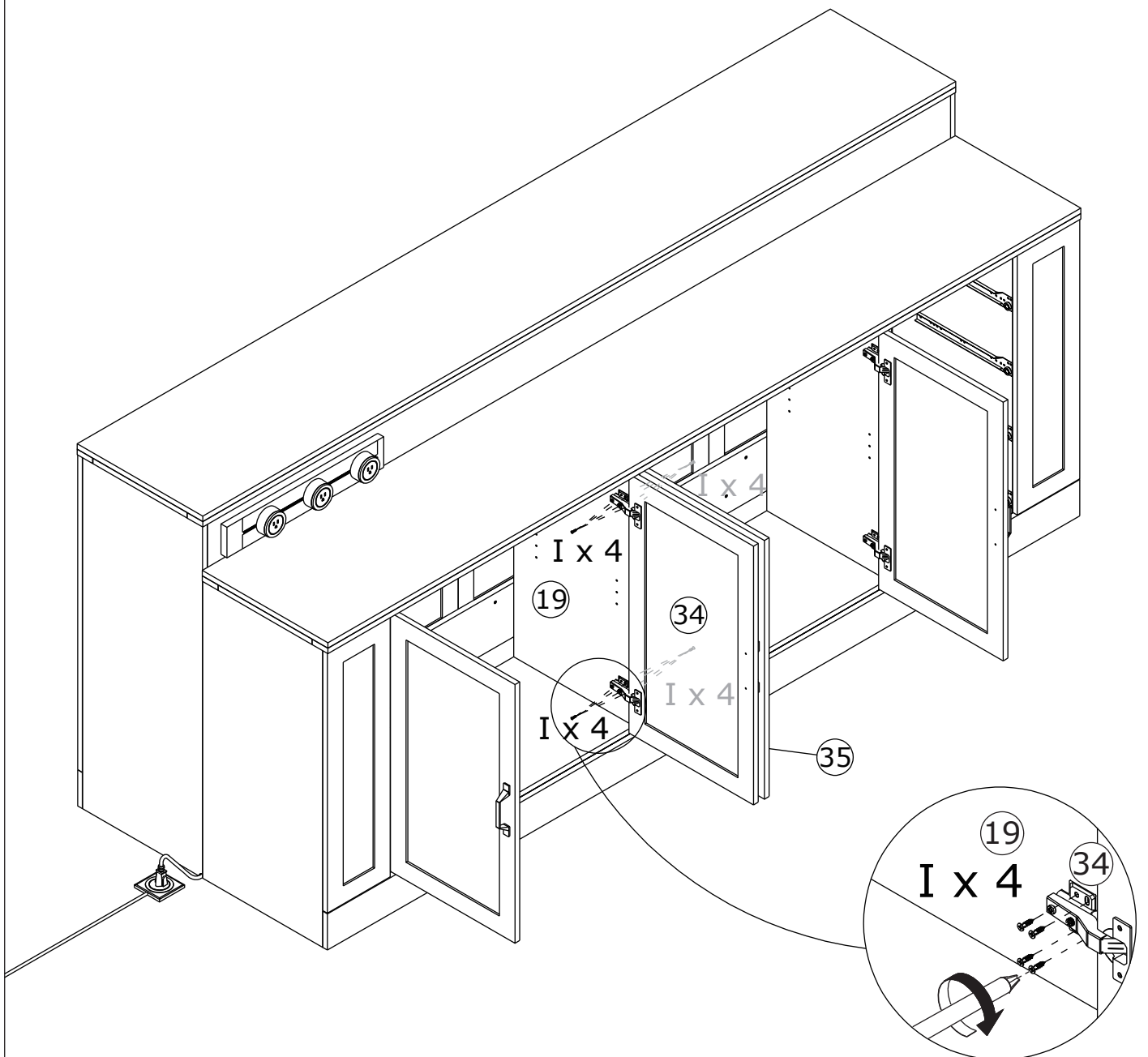

44

J x 8



Insert layer pin(J) into board 18, 19 and 20 at first.

Insérez d'abord la broche de couche (J) dans les cartes 18, 19 et 20.

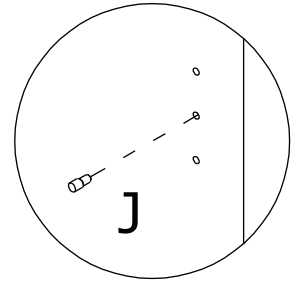

OR

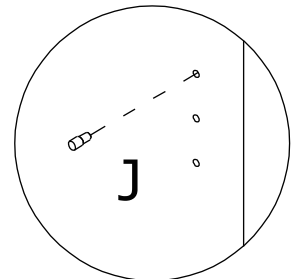

OR

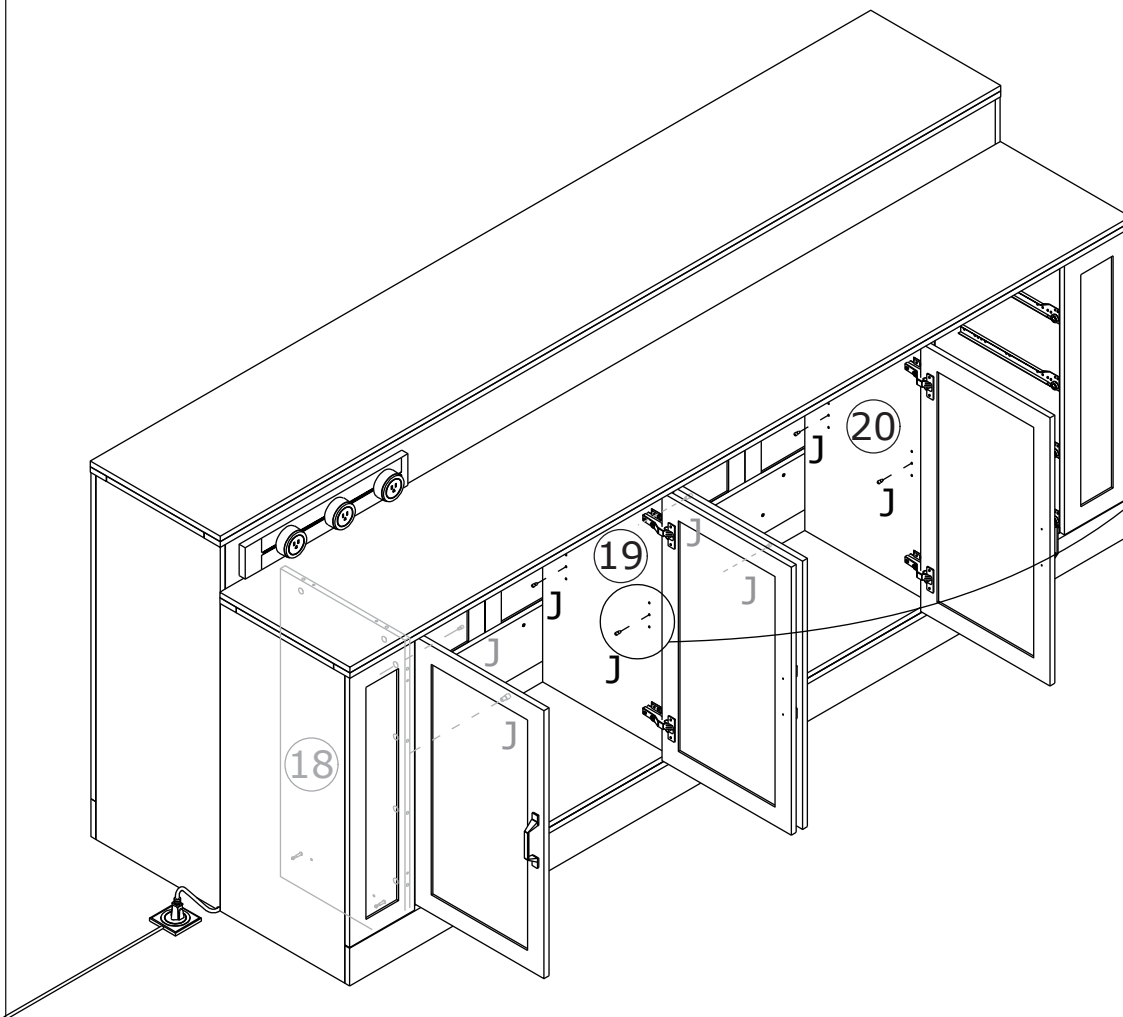
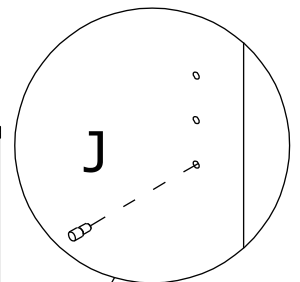

45

Place shelf board 42 on.

Placez l'étagère 42.

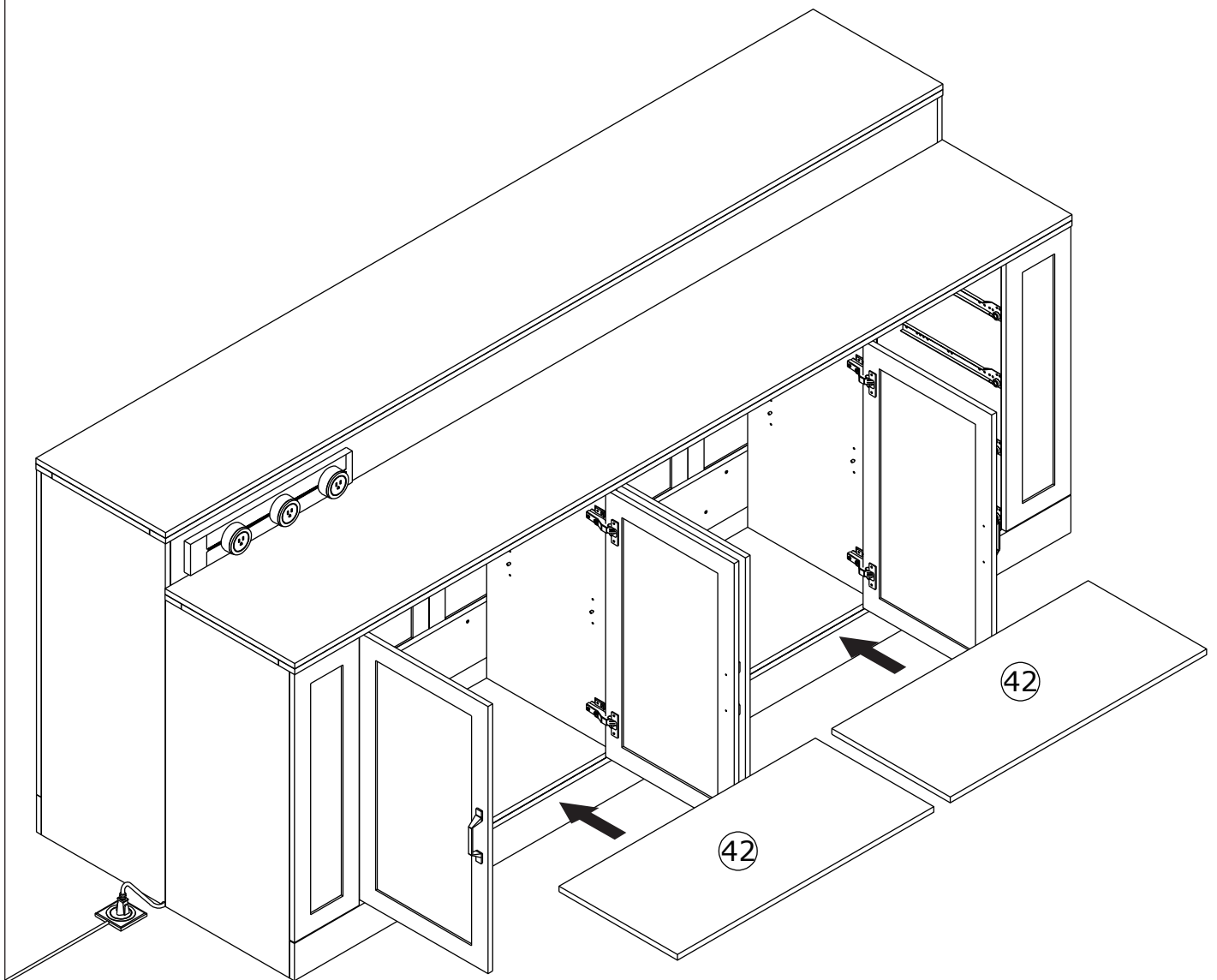

46

C x 16

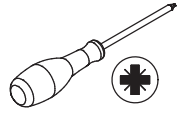

Fix board 40 to board 38 and 39 using screw(C) as shown.
Insert board 41 along available grooves as shown.

Fixez la planche 40 aux planches 38 et 39 à l'aide de la vis (C) comme indiqué.
Insérez la planche 41 le long des rainures disponibles comme indiqué.

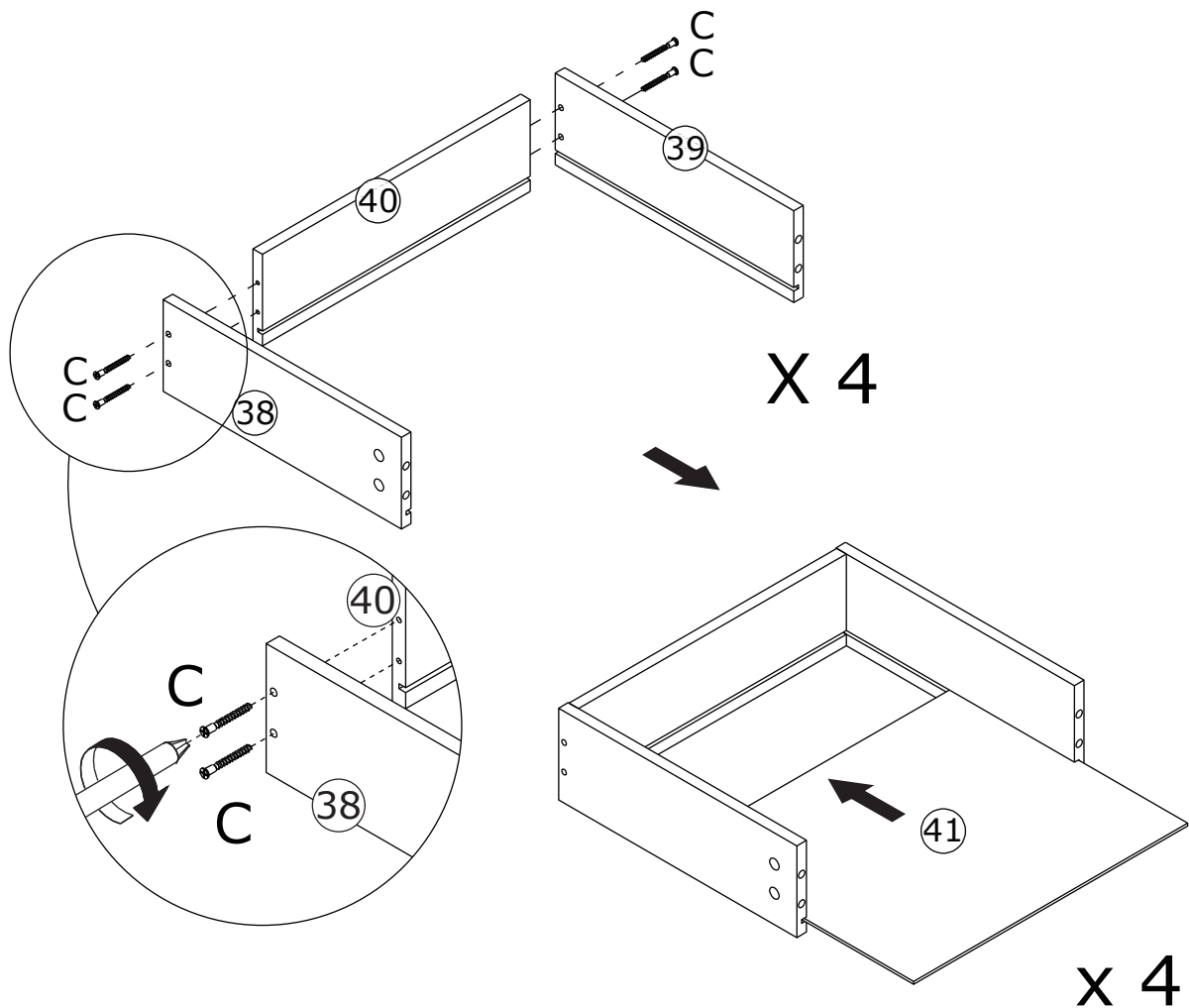

47

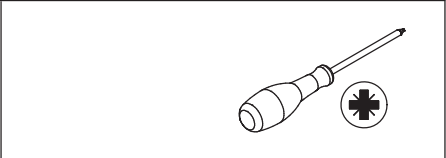
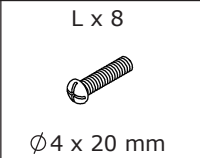
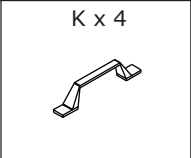

Screw eccentric rod(B) into board 37 and fix handle(K) with screw(L) as shown.

Vissez la tige excentrique (B) dans la planche 37 et fixez la poignée (K) à l'aide de la vis (L) comme indiqué.

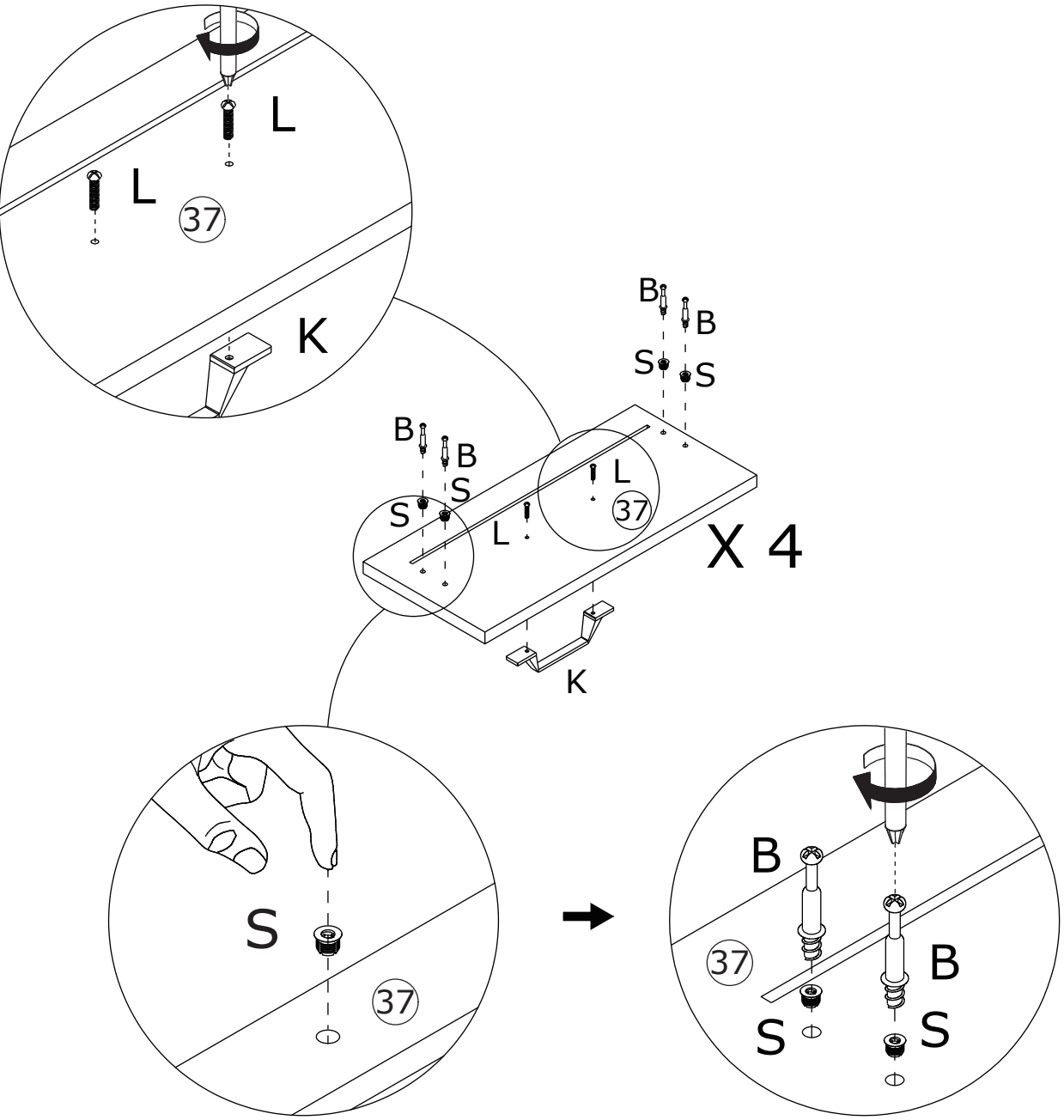
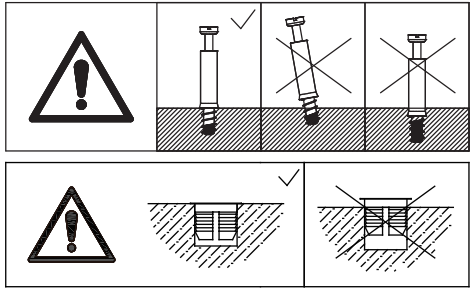

48

A x 16
Ø15 x 10 mm

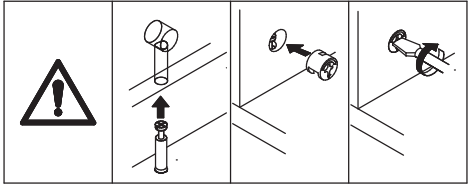
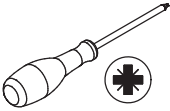

Attach board 37 to board 38 and 39, add cam lock(A) into and turn clockwise to tighten as shown.

Fixez la planche 37 aux planches 38 et 39, ajoutez le verrou à came (A) et tournez-le dans le sens des aiguilles d'une montre pour le serrer, comme indiqué.

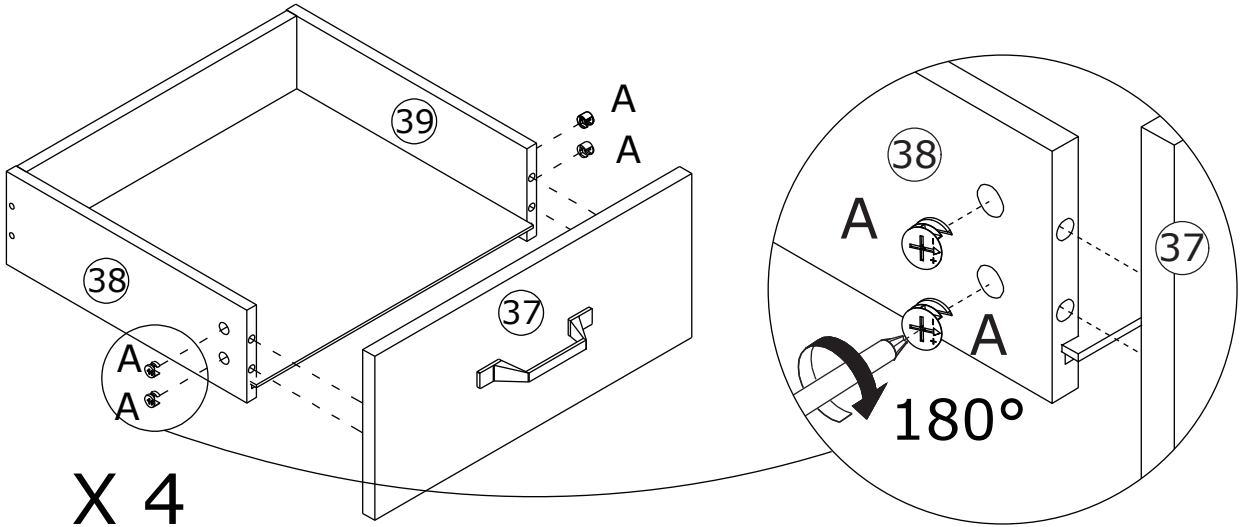

49

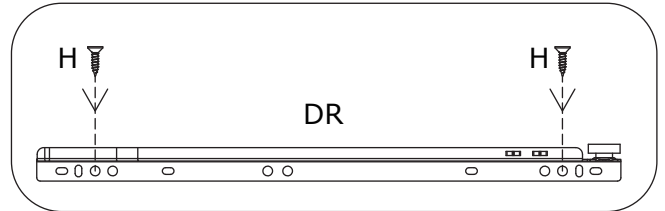
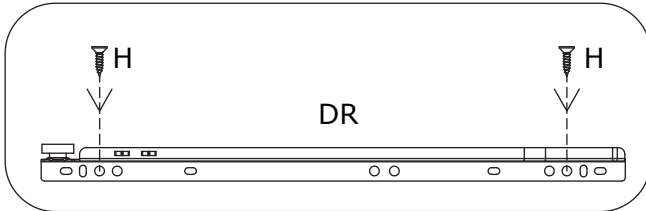
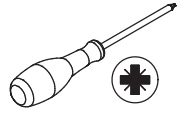
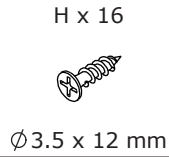
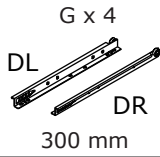

Fix track(DL) and (DR) to board 38 and 39 with screw(H) as shown.

Fixez les rails (DL) et (DR) aux cartes 38 et 39 à l'aide de vis (H) comme indiqué.

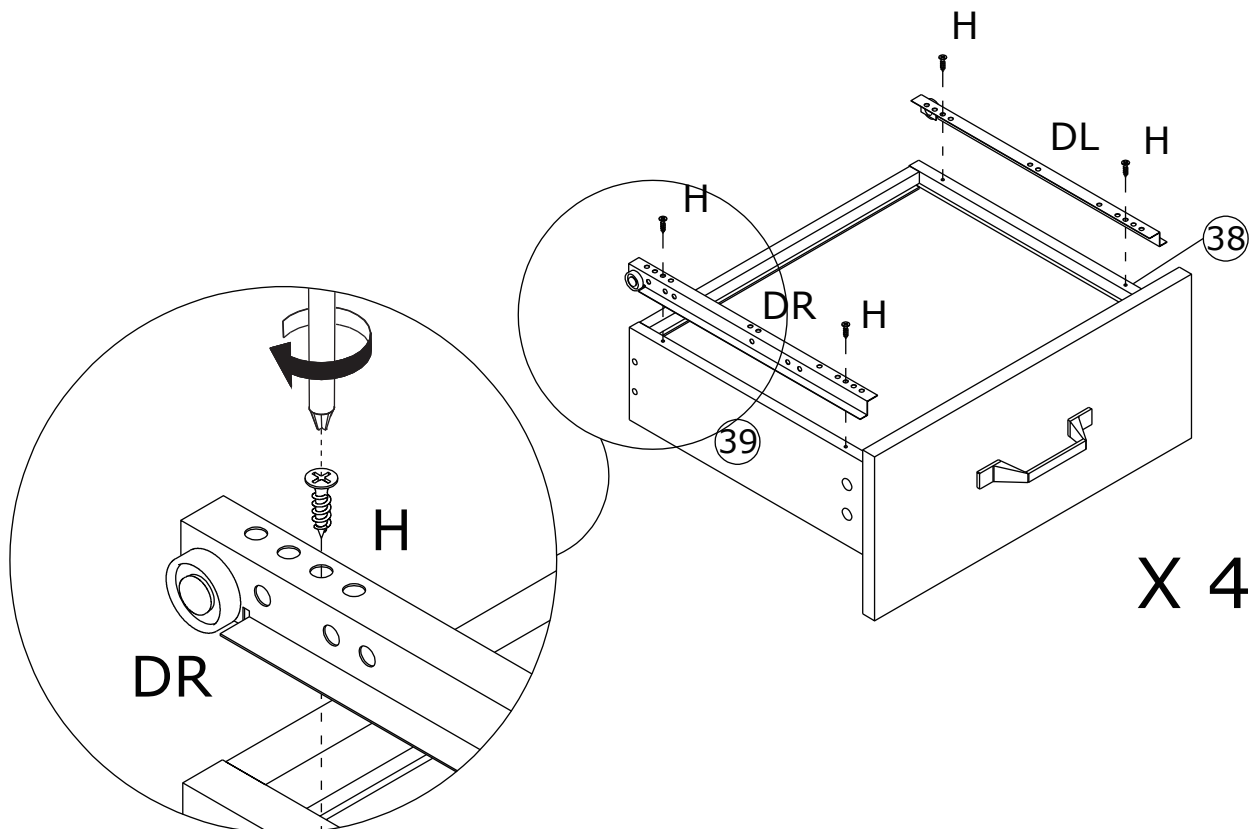

X 4

50

Align rails, slide all drawers in.

Alignez les rails, faites glisser
tous les tiroirs vers l'intérieur.

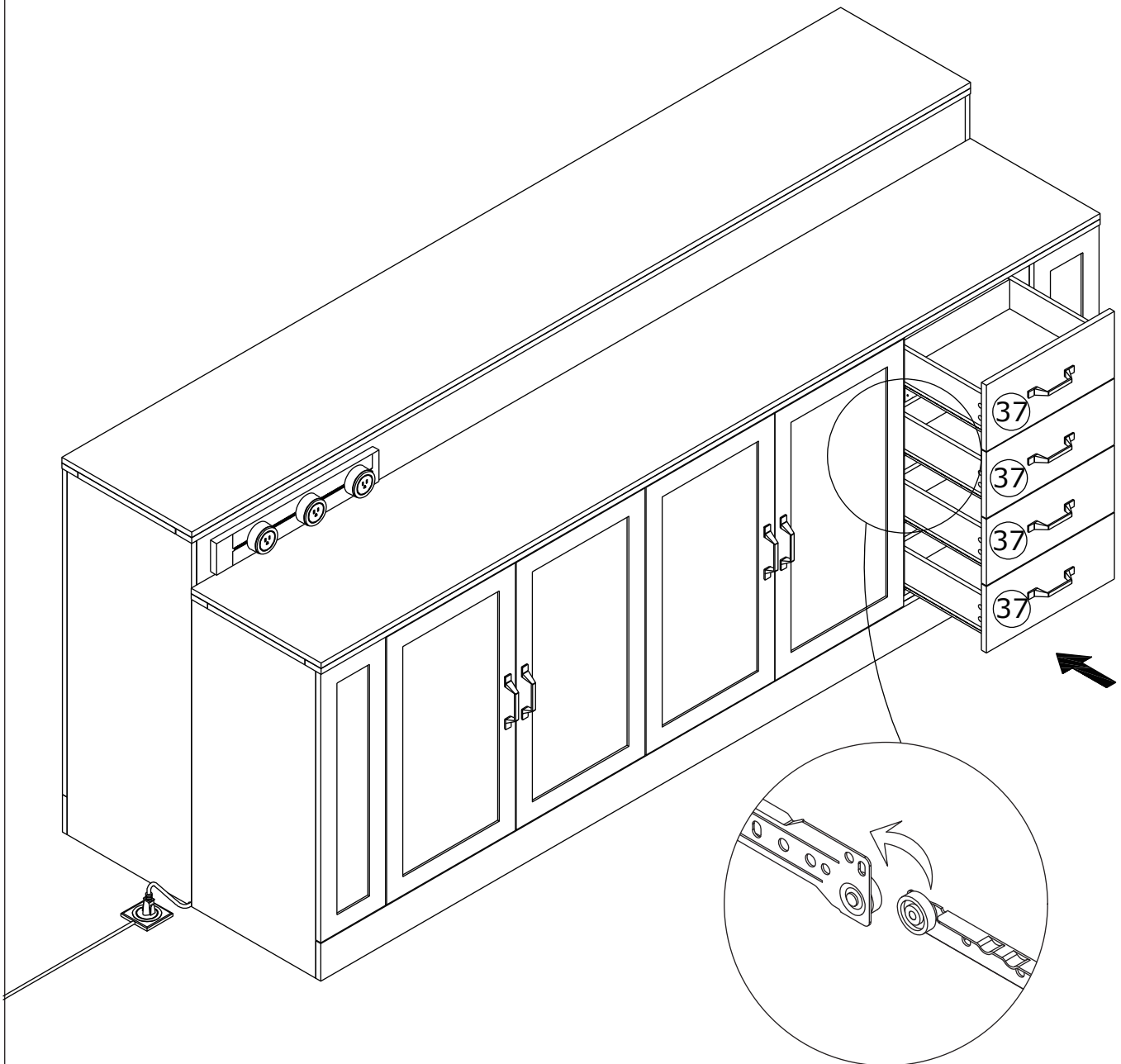

WARRANTY

WARRANTY CLAIMS

- There is a 30-day warranty for broken furniture or any other problems that do not work properly. The warranty will start from the date of purchase which must be verified by proof of purchase.
- Before making a claim, we may be able to answer your query, simply call us. Please leave your purchase order number, along with some details of the problem, if you want a replacement part. We will arrange within 48 hours. If there is out of stock, we will reply with a shipping date.
- The product must be used in accordance with the instructions provided. For health reasons.
- For other reasons, if the furniture needs to be returned, it must be cleaned and dried and operated within 30 days of receipt.

Type of Warranty Claim

- Failure to follow the furniture instructions will invalidate the warranty. Attention please.
- Does not include damage during installation, but includes damage during transportation.

Scope of responsibility

- Shall not bear any responsibility for misuse or user damage and / or loss of parts during the installation of furniture.
- After using, the damage and scratches of the furniture are not covered by the warranty.

The Warranty Relates to All Bought in The Us and Covers The Following Areas

- Sheet parts: 1 month from the date of purchase.
- Electrical parts: 1 month from the date of purchase.

GARANTIE

RÉCLAMATIONS DE GARANTIE

Il existe une garantie de 30 jours pour les meubles cassés ou tout autre problème qui ne fonctionne pas correctement. La garantie commencera à partir de la date d'achat qui doit être vérifiée par une preuve d'achat.

Avant de faire une réclamation, nous pourrions peut-être répondre à votre demande, il vous suffit de nous appeler. Veuillez laisser votre numéro de bon de commande, ainsi que quelques détails sur le problème, si vous voulez une pièce de rechange. Nous organiserons dans les 48 heures. En cas de rupture de stock, nous vous répondrons avec une date d'expédition.

Le produit doit être utilisé conformément aux instructions fournies. Pour des raisons de santé.

Pour d'autres raisons, si les meubles doivent être retournés, ils doivent être nettoyés et séchés et utilisés dans les 30 jours suivant leur réception.

Type de demande de garantie

Le non-respect des instructions du meuble annulera la garantie. Attention, s'il vous plaît. N'inclut pas les dommages pendant l'installation, mais inclut les dommages pendant le transport.

Portée de la responsabilité

N'assume aucune responsabilité en cas de mauvaise utilisation ou de dommages causés par l'utilisateur et / ou de perte de pièces lors de l'installation du meuble.

Après utilisation, les dommages et rayures du meuble ne sont pas couverts par la garantie.

La garantie s'applique à tous les produits achetés aux États-Unis, dans tous les pays d'Europe et couvre les domaines suivants:

Pièces en tôle: 1 mois à compter de la date d'achat.

Pièces électriques: 1 mois à compter de la date d'achat..

RETURNS

CHANGED YOUR MIND AND NEED TO RETURN YOU ITEM?

PLEASE FOLLOW THE BELOW INSTRUCTIONS:

- If you have purchased and have simply changed your mind, follow the retailer's instructions for returns.

DEFECTIVE ITEMS

- If your item is defective in any way, i.e. it doesn't work but you can't identify why, in the first instance, please call us.

DAMAGED ITEMS

- If you receive an order with obvious shipping damage from the retailer, then we suggest the delivery is refused. If the delivery has been accepted and then shipping damage is found, please follow the specific instructions advised by the retailer. In all circumstances please save all packaging material and paperwork for the order. Please be aware that if you dispose of packaging material or attempt to return the merchandise without contacting the fulfiller, you jeopardise your chances of making a claim, and you may not receive a credit for the return.

AFTER-SALES CONTACT



adelahu@fufugaga.com



208-820-0068

RETOUR

VOUS AVEZ CHANGE D'AVIS ET VOUS AVEZ BESOIN DE RETOURNER VOTRE ARTICLE ?

VEUILLEZ SUIVRE LES INSTRUCTIONS CI-DESSOUS:

Si vous avez acheté et que vous avez simplement changé d'avis, suivez les instructions du détaillant pour les retours.

ARTICLES DÉFECTUEUX

Si votre article est défectueux de quelque manière que ce soit, c'est-à-dire qu'il ne fonctionne pas, mais que vous ne pouvez pas identifier pourquoi, en premier lieu, veuillez nous appeler.

ARTICLES ENDOMMAGÉS

Si vous recevez une commande avec des dommages d'expédition évidents du détaillant, nous suggérons que la livraison soit refusée. Si la livraison a été acceptée et que des dommages d'expédition sont constatés, veuillez suivre les instructions spécifiques conseillées par le détaillant.

Dans tous les cas, veuillez conserver tout le matériel d'emballage et les documents pour la commande.

Veuillez noter que si vous vous débarrassez du matériel d'emballage ou tentez de retourner le

Marchandise Sans contacter le remplisseur, vous compromettez vos chances de faire une réclamation, et vous ne pouvez pas recevoir de crédit pour le retour.

