

# Assembly Instructions

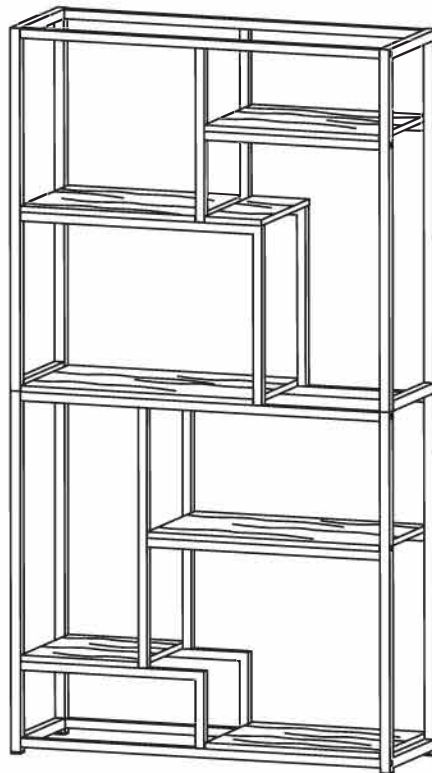

## ASSEMBLY RATING

The Assembly Rating is a 5-point system that shows the degree of effort needed in assembling a specific product (with 1 being easy and 5 being difficult). For some products, two persons are recommended.

EASY



DIFFICULT

## Tools Required For Assembly:

Allen Wrench



(Included)

Phillips Screwdriver



(Not Included)



2 PERSONS RECOMMENDED

# ASSEMBLY & CARE ADVICE

FOR YOUR FURNITURE TO LAST, CORRECT ASSEMBLY AND PROPER MAINTENANCE ARE NECESSARY. PLEASE FOLLOW THE INFORMATION PROVIDED BELOW TO FULLY ENJOY YOUR FURNITURE.

## BASIC ASSEMBLY TECHNIQUES



When lock or spring washer is used in an assembly, please make sure the lock or spring washer is placed between the larger flat washer and the head of the screw or bolt.

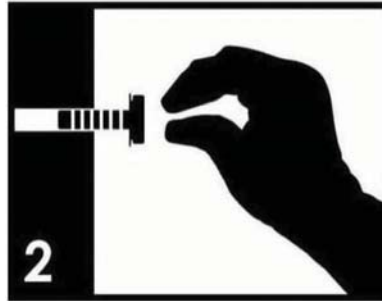

Position each part correctly and insert screws or bolts into their respective holes by hand tighten or using the proper hand tool. Only tighten when step is completed or when instructed to do so.

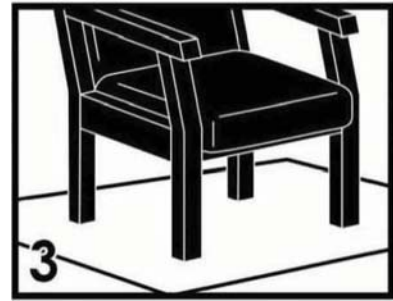

Use cardboard or carpet area when assembling furniture to prevent scratches. Make sure the furniture rests on a flat and level surface with each leg evenly touching the floor.



Some furniture comes with height adjustment knobs underneath each leg. To lower or to raise each leg, you need to turn clockwise or counterclockwise, respectively.

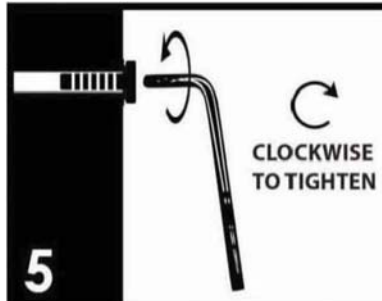

Make sure all parts are properly aligned, then use the appropriate hand tool to completely tighten the bolts or screws. Do not use power tools and do not overtighten.

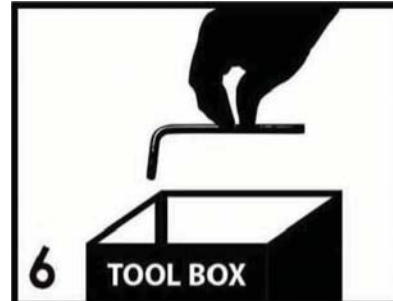

Save the instructions and store the Allen wrench or any supplied tool for later maintenance. After two weeks, check and tighten any loose hardware and repeat again every six months thereafter.

IT IS THE USER'S RESPONSIBILITY TO MAINTAIN THE FURNITURE. THE HARDWARE MAY LOOSEN OVER TIME AND MAY CAUSE THE FURNITURE TO BE WOBBLY AND UNABLE TO SUPPORT ITS INTENDED WEIGHT CAPACITY. THIS MAY LEAD TO COLLAPSE AND MAY CAUSE SERIOUS INJURY.



**FAILURE TO FOLLOW THE GUIDELINES ABOVE MAY RESULT IN INJURY AND/OR PROPERTY DAMAGE.**

ALL RIGHTS RESERVED.



Before you begin, please read Page 2 of "Assembly and Care Advice".

And remember, do not tighten until each step is completed or instructed.

### Parts List



#1 x 1pc  
Left Side Frame ( Up )



#2 x 1pc  
Right Side Frame ( Up )



#3 x 1pc  
Left Side Frame ( Down )



#4 x 1pc  
Right Side Frame ( Down )



#5 x 2pcs  
Stretcher 5 928mm ( 1 Hole )



#6 x 2pcs  
Stretcher 6 928mm ( 4 Hole )



#7 x 2pcs  
Stretcher 7 928mm ( 3 Hole )



#8 x 2pcs  
Stretcher 8 427mm

### Hardware List



#9 x 2pcs  
Stretcher 9 455mm

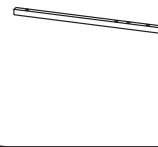

#10 x 2pcs  
Stretcher 10 Large



#11 x 2pcs  
Stretcher 11 660mm



#12 x 2pcs  
Stretcher 12 604mm



#13 x 2pcs  
Stretcher 13 Small



#14 x 3pcs  
Wood Shelf 14 451x336mm



#15 x 2pcs  
Wood Shelf 15 600x336mm



#16 x 1pc  
Wood Shelf 16 150x336mm

## Parts List



#17 x 1pc

Wood Shelf 17 302x336mm

## Hardware List



#A x 6pcs

Flat Bolt 1/4"x1/2"

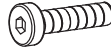

#B x 34pcs

Bolt 1/4" x 1-1/2"



#C x 2pcs

Bolt 1/4"X1-1/2"



#D x 26pcs

Screw 1-1/4"



#E x 4pcs

L Bracket



#F x 2pcs

Wall Anchor



#G x 2pcs

Screw 1"



#H x 2pcs

Plastic Strap

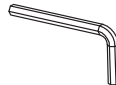

#I x 1pc

Allen Wrench



#1

2. Insert a flat bolt (#A) into the holes. Secure using the Allen wrench (#H) to lock the side frames together.

#A x 4pcs

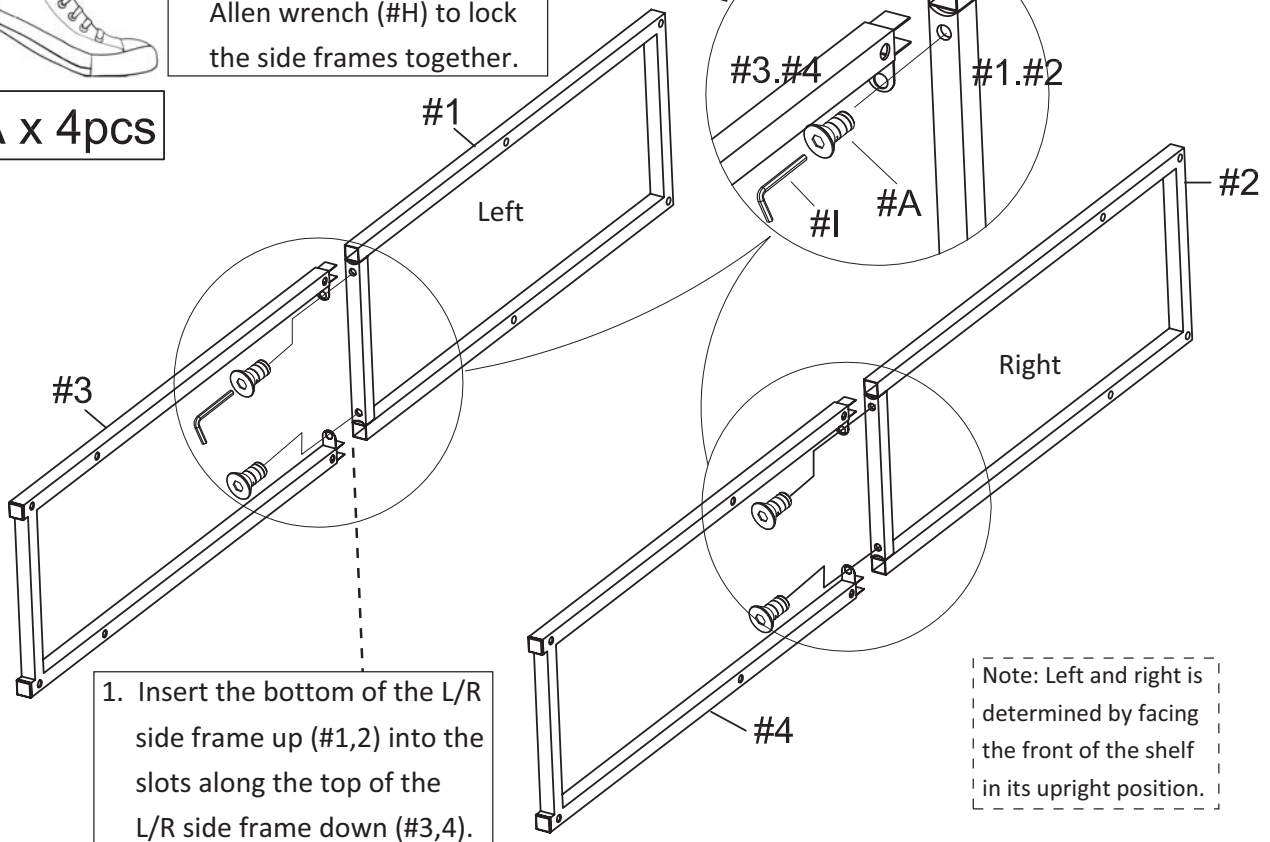

#2

1. Place both side frames onto a protected surface. Align the stretchers to the side frames. Stretchers (#5) align to the top, stretchers (#6) to the center, and stretchers (#7) to the bottom holes.

#B x 12pcs

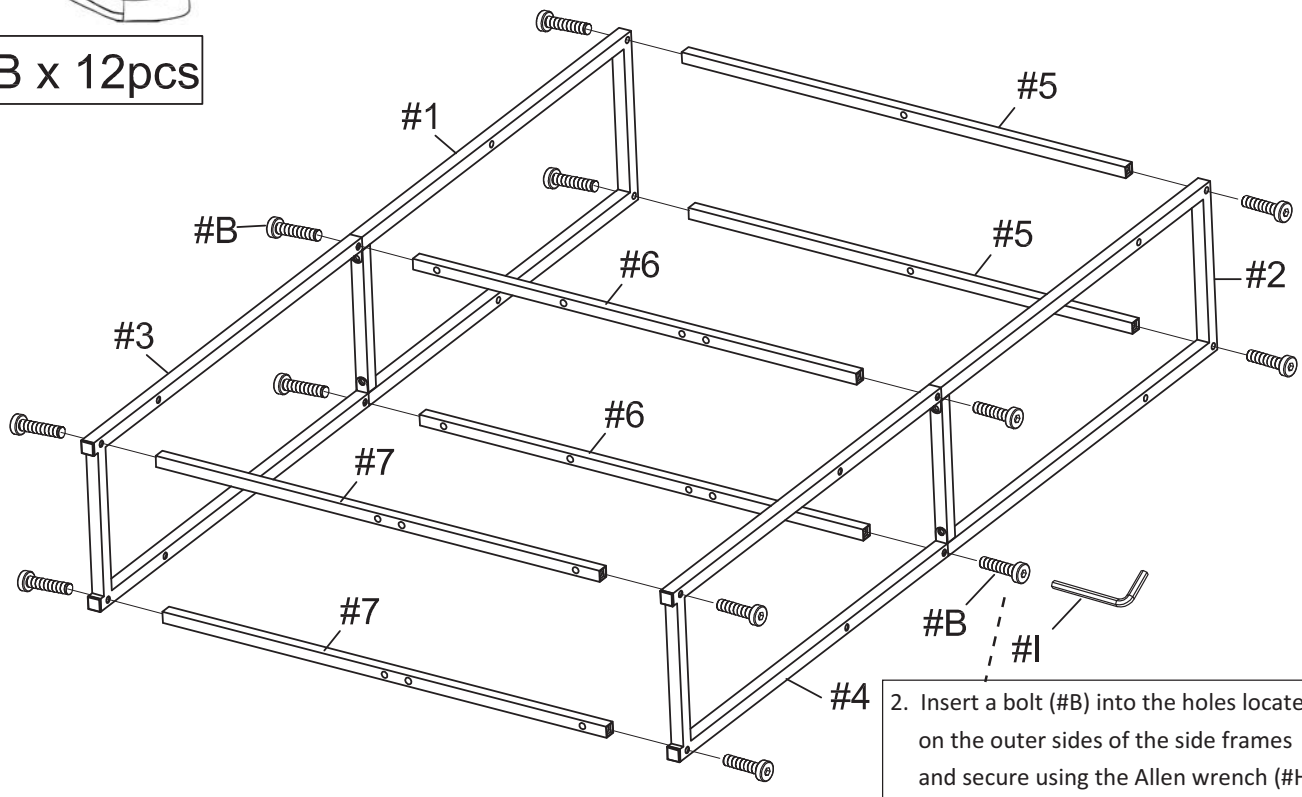



#3

1. Align the stretchers (#8, 9,10) as shown below.

#B x 12pcs

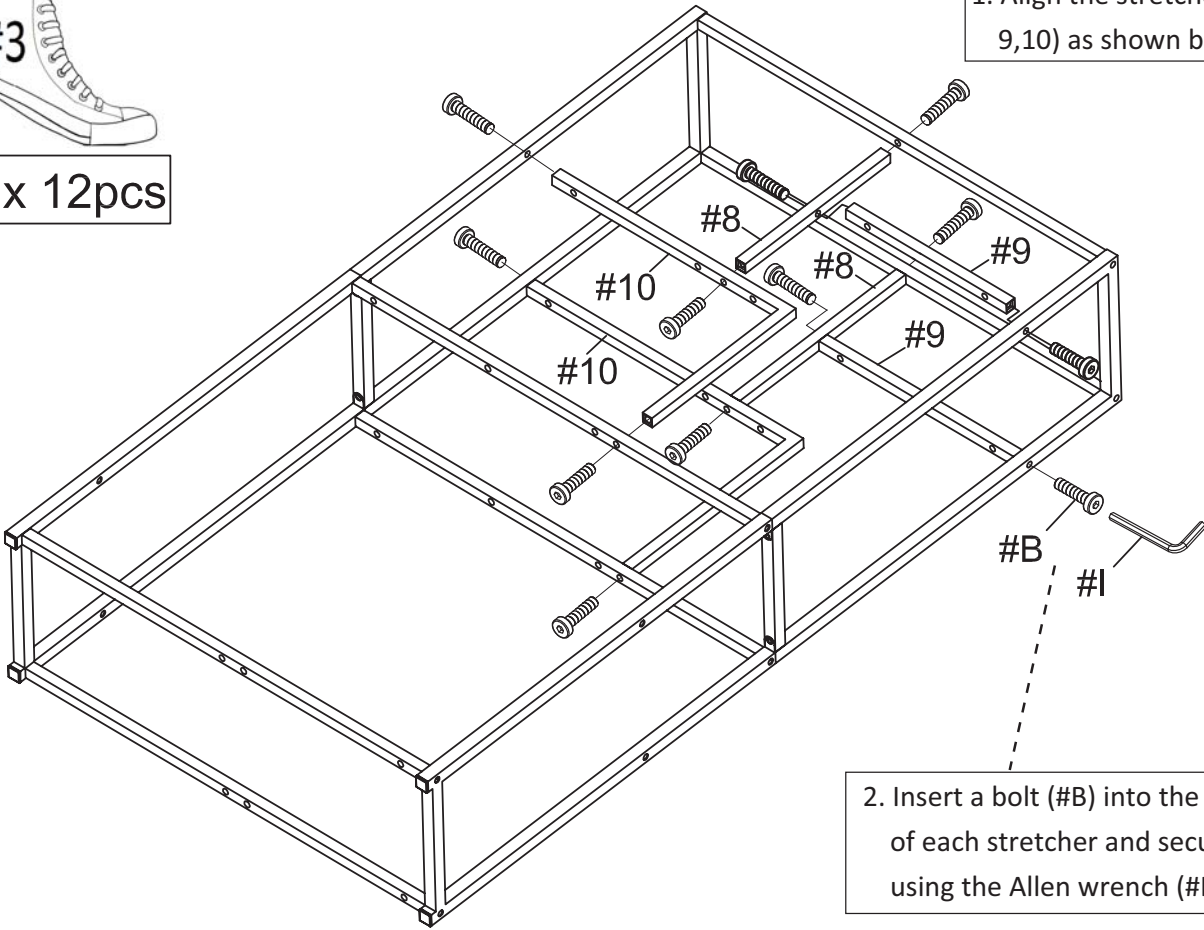

2. Insert a bolt (#B) into the ends of each stretcher and secure using the Allen wrench (#I)



#4

1. Align the stretchers (#11, 12,13) as shown below.

#B x 10pcs  
#C x 2pcs

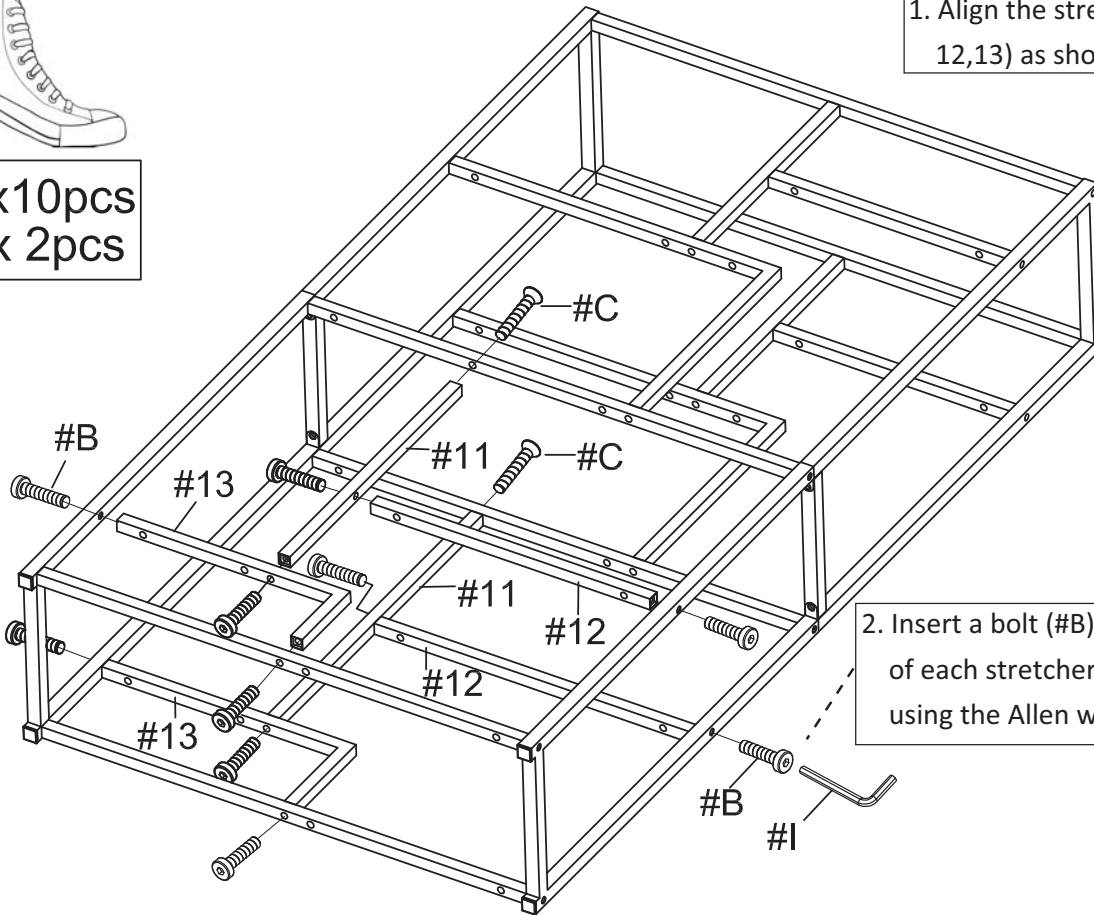

2. Insert a bolt (#B) into the ends of each stretcher and secure using the Allen wrench (#I)



#5

1. Place the wood shelves (#14) onto the slots displayed below.

#D x 12 pcs

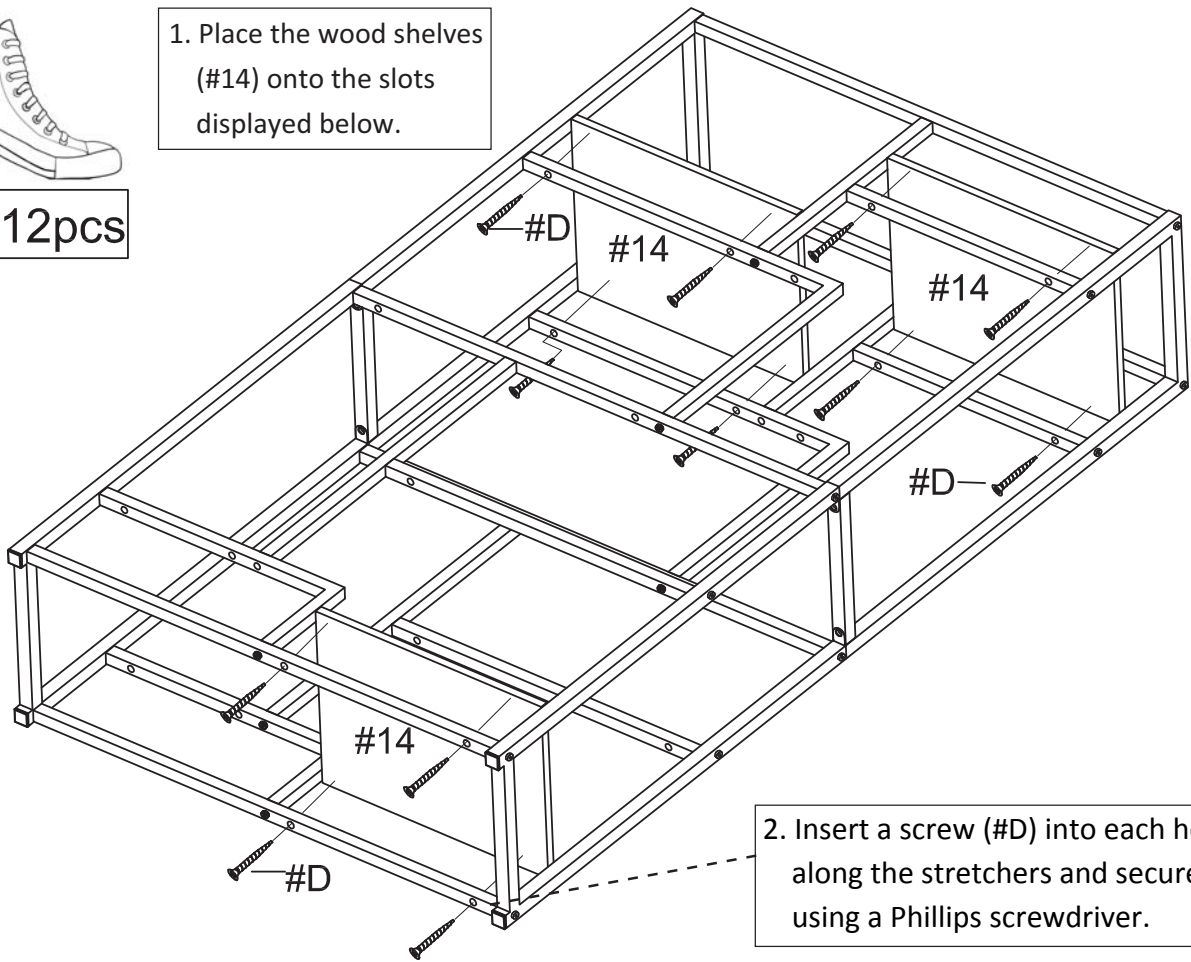

2. Insert a screw (#D) into each hole along the stretchers and secure using a Phillips screwdriver.



#6

1. Place the wood shelves (#15) on to the slots displayed below.

#D x 8 pcs

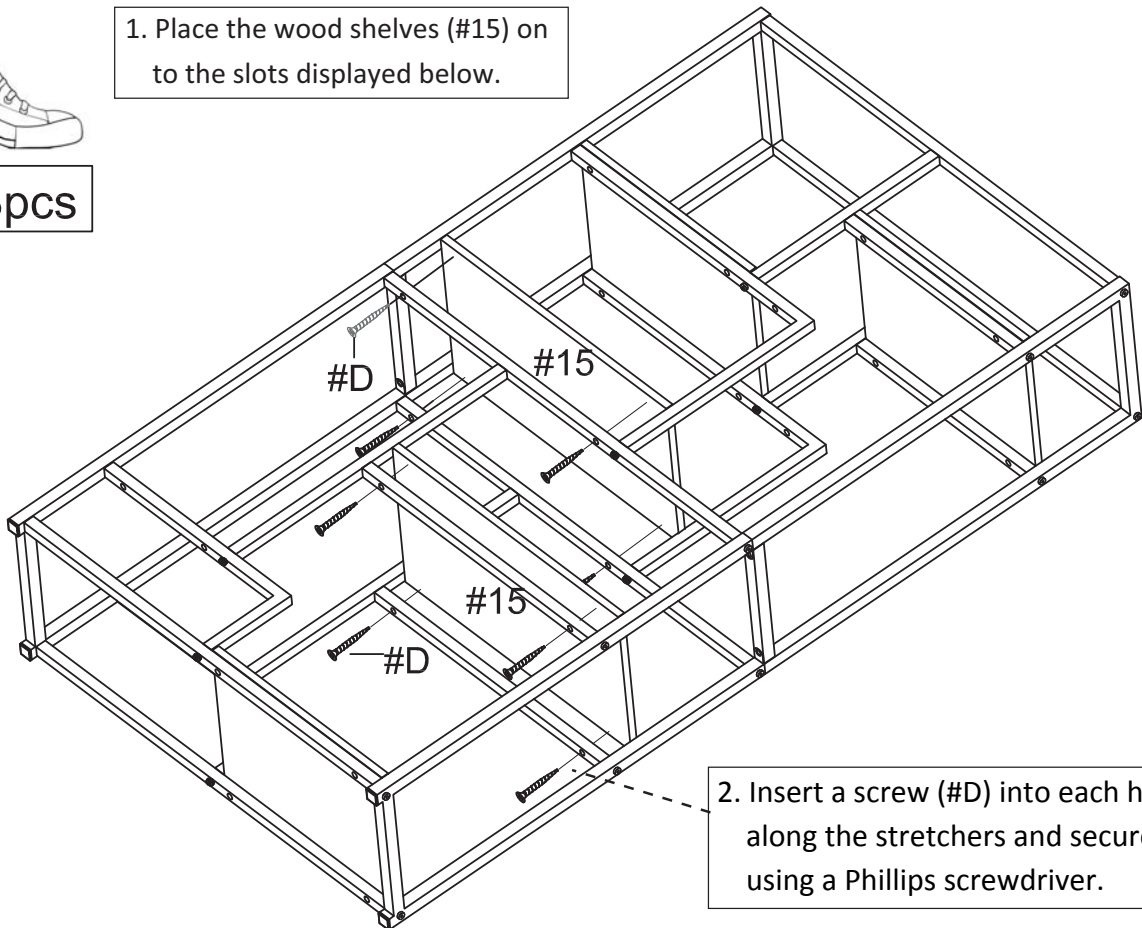

2. Insert a screw (#D) into each hole along the stretchers and secure using a Phillips screwdriver.



#7

1. Place the wood shelves (#16, 17) onto the slots displayed below.

#D x 6pcs

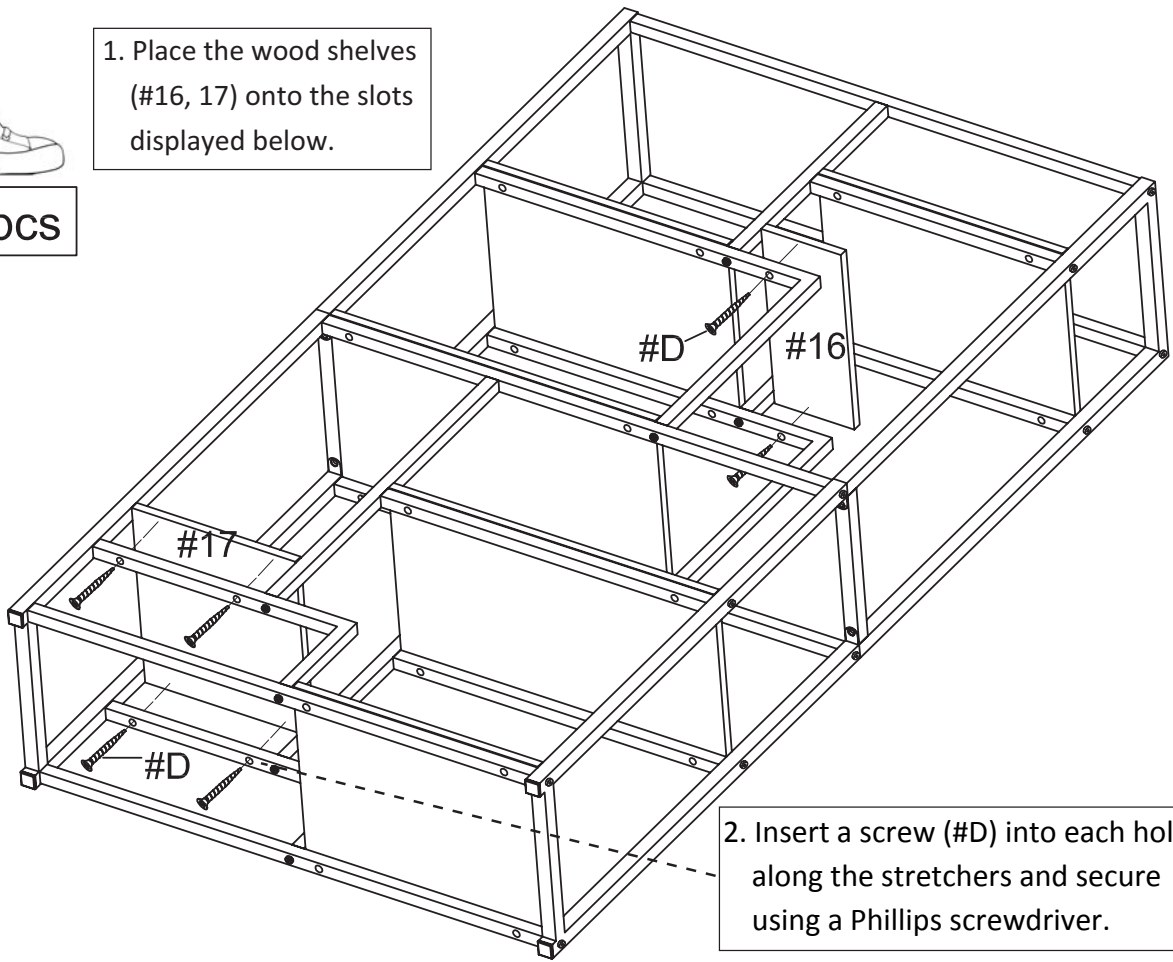

2. Insert a screw (#D) into each hole along the stretchers and secure using a Phillips screwdriver.



#8

#E x 2pcs  
#F x 2pcs  
#G x 2pcs

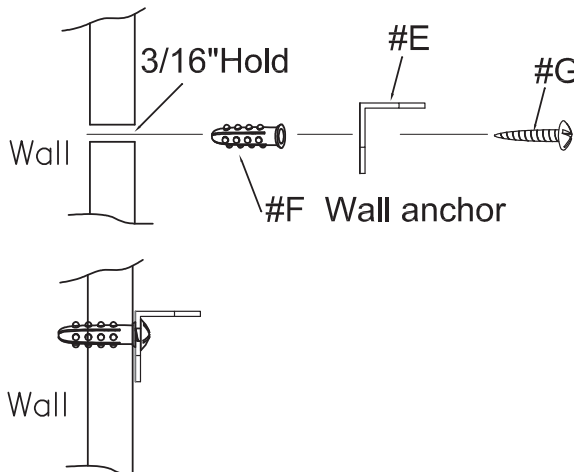
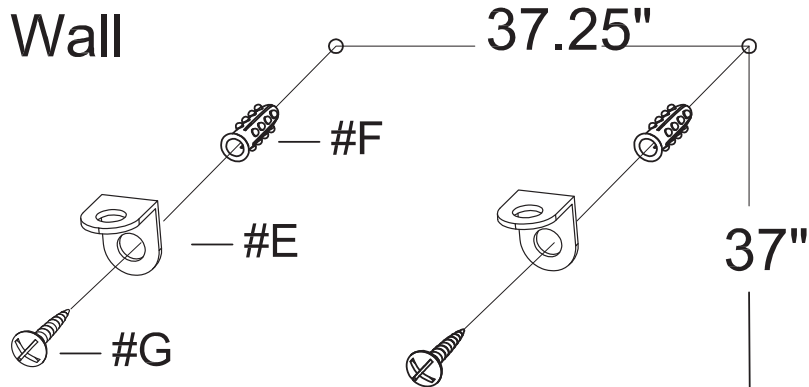

Select a location where you want the shelf mounted. Mark on the wall the two locations where the wall anchors (#F) will be placed. Drill a hole for each anchor slightly smaller than the size of the screw. Push the anchor (#F) as far as it will go with your finger. Tap gently with a hammer until the anchor is in. Then align the L brackets (#E) to the anchor and insert a screw (#G) to secure.



#A x 2pcs  
#E x 2pcs

Align the L brackets (#E) to the back sides and insert a flat bolt (#A).  
Secure using the Allen wrench (#I).

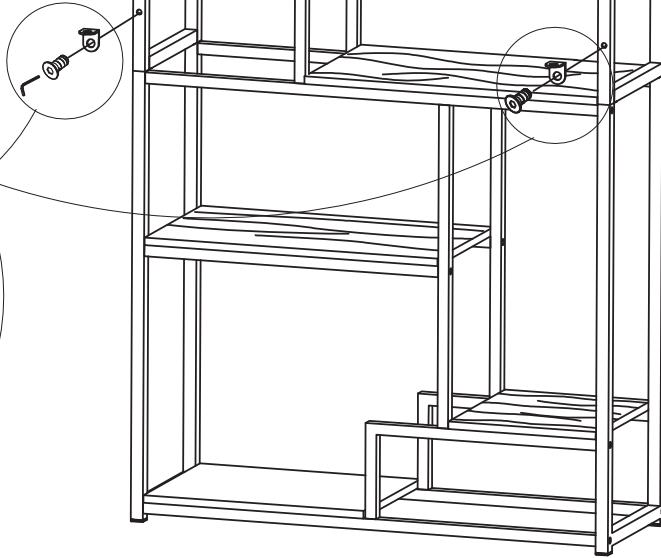
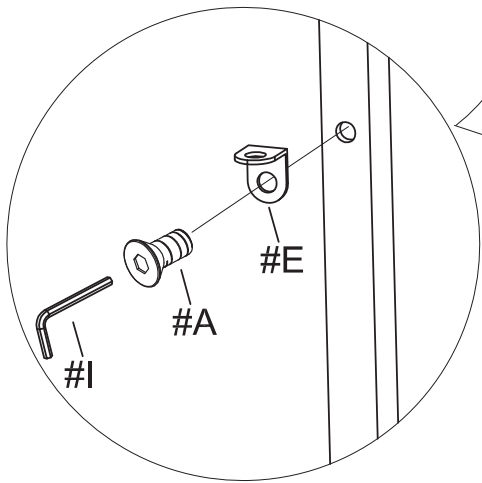

#H x 2pcs

Insert each end of the plastic strap (#H) into the L brackets (#E), then secure and tighten.

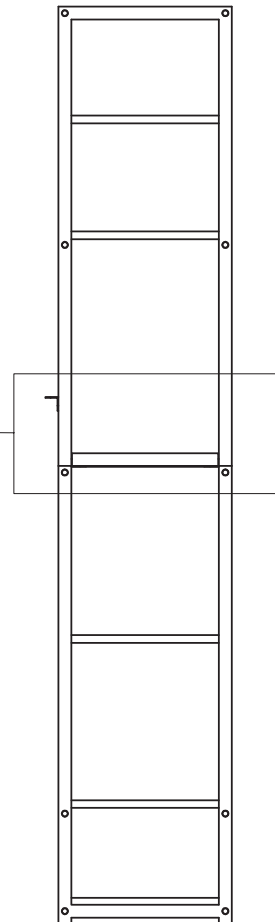
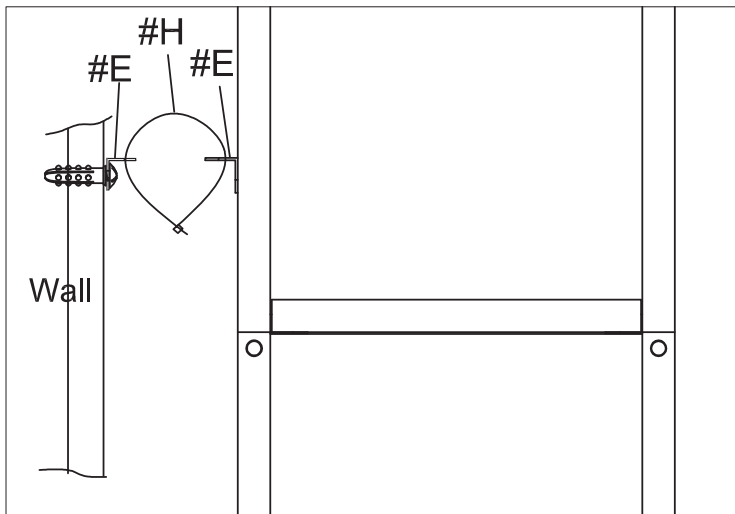

ASSEMBLY IS COMPLETED