

# HAPPINESS HAPPINESS INSTALLATION



## CAUTION

Parts are placed at the bottom of the product.

- If you have any questions with the product, please contact us by:
- **Email: [customerservice@zoy-living.com](mailto:customerservice@zoy-living.com)**  
(we will reply to you within 24 hours)

# Assembly Instructions







## CAUTION

**DO NOT** use any sharp objects to open plastic wrapped components as this may result damage to product or components .

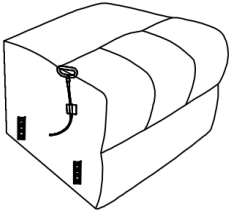
Model: CR6315Q

The product (sectional) comes packaged in **two** kinds of packages. Carefully remove all of components from the packaging and set aside for assembly.

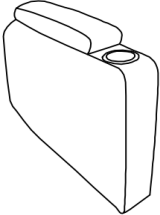
## Package Contents

<b>BOX 1</b> CR6315QF51D				
	<b>A*1 Seat Frame</b>	<b>B*1 Left Ear</b>	<b>C*1 Right Ear</b>	
<b>BOX 2</b> CR6315QF51D				
	<b>D*1 Backrest</b>	<b>E*1 Left Armrest</b>	<b>F*1 Right Armrest</b>	

# 1 SECTIONAL ASSEMBLY - BODY SETUP

## Step 1:

Attach the Left Armrest(when facing the chair)(E) and Right Armrest(when facing the chair)(F) to the Seat Frame(A) by the metal slider. Ensure the armrest is fully inserted to the bottom along the metal slider to avoid tilting or moving.

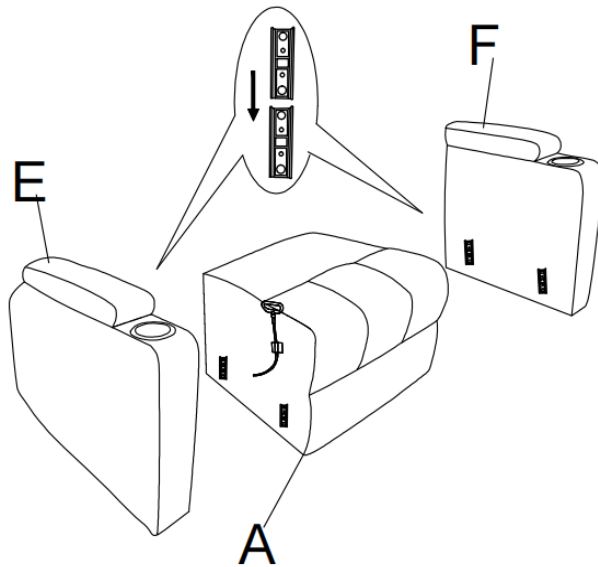

## Step 2:

Assemble the Backrest(D) to its Seat Frame(A), making sure it is securely installed before using.

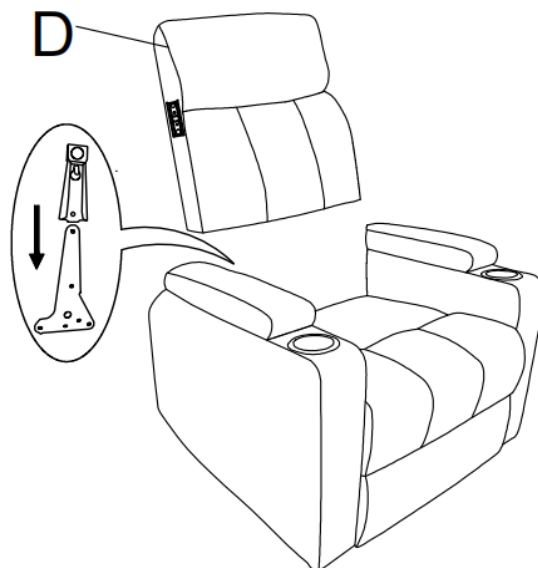

# 2 SECTIONAL ASSEMBLY - BODY SETUP

## Step3:

Attach the Left Ear (when facing the chair) (B) and Right Ear (when facing the chair) (C) to the Seat Frame (D) by the metal slider. Ensure the armrest is fully inserted to the bottom along the metal slider to avoid tilting or moving.

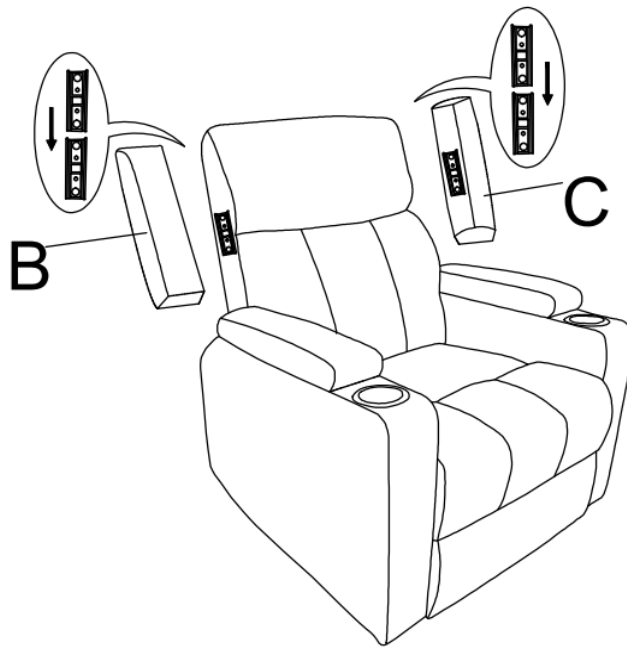

**ASSEMBLY COMPLETED**

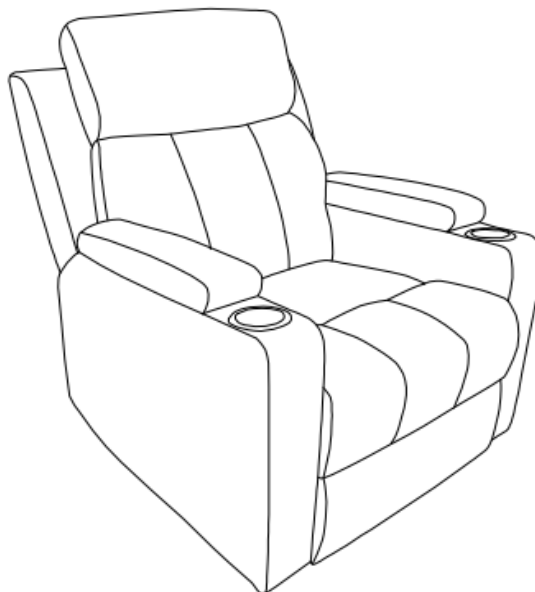

# 3 INSTRUCTIONS FOR USE - SIZE DIMENSIONS

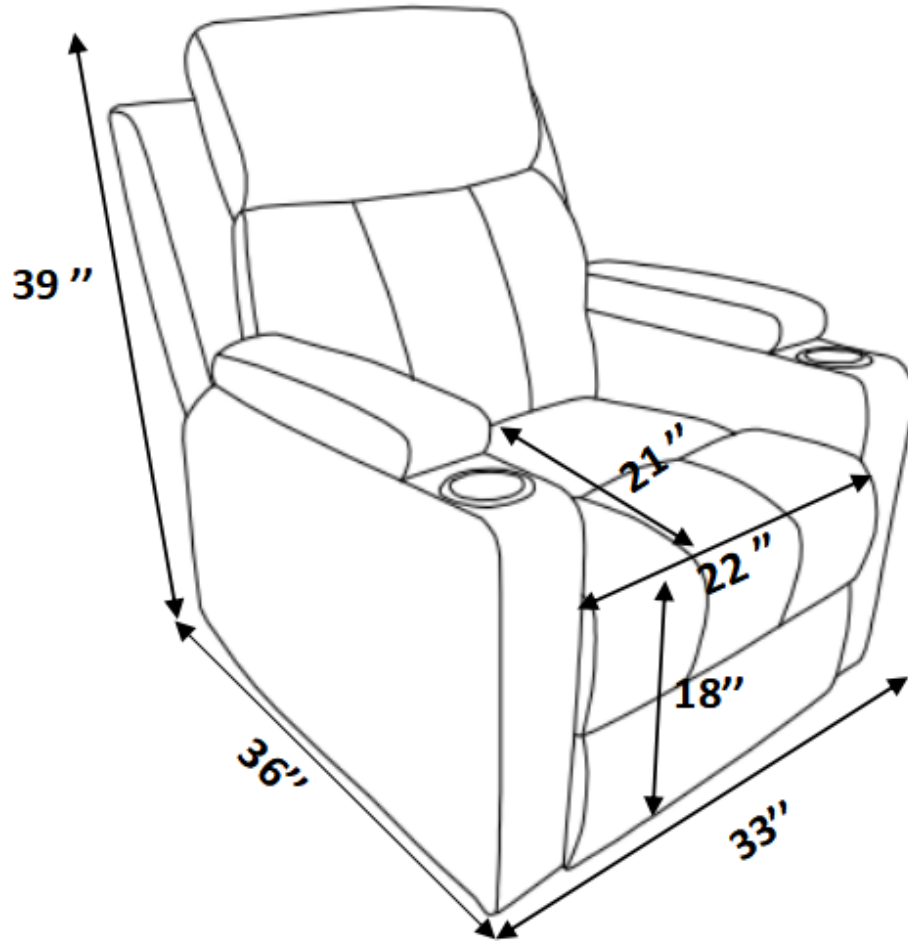

Manual Recliner

CR6315QF51D

## ⚠️ WARNINGS

1. Please check if the components of the chair are all included and can be used normally.
2. Assemble all components according to the instruction correctly before you connect the chair to the power.
3. Please DO NOT sit on the armrests or footrest to eliminate the risk of tipping over.
4. If the chair is damaged or doesn't match the website description, please send clear pictures of the product and label of the carton to our service team for further help.
5. If the recliner doesn't work, you may try the following measures for self-checking firstly:
  - a) check if all the cables are connected;
  - b) check if the light of transformer is on.

If the chair still doesn't work, please feed the information back to our customer service in time and we will help you solve the matter as soon as possible.

6. If you have any questions about our products, please contact us by:

Email: [customerservice@zoy-living.com](mailto:customerservice@zoy-living.com) (we will respond to your inquiry within 24 hours)

