

BAMBOO FLOOR CABINET

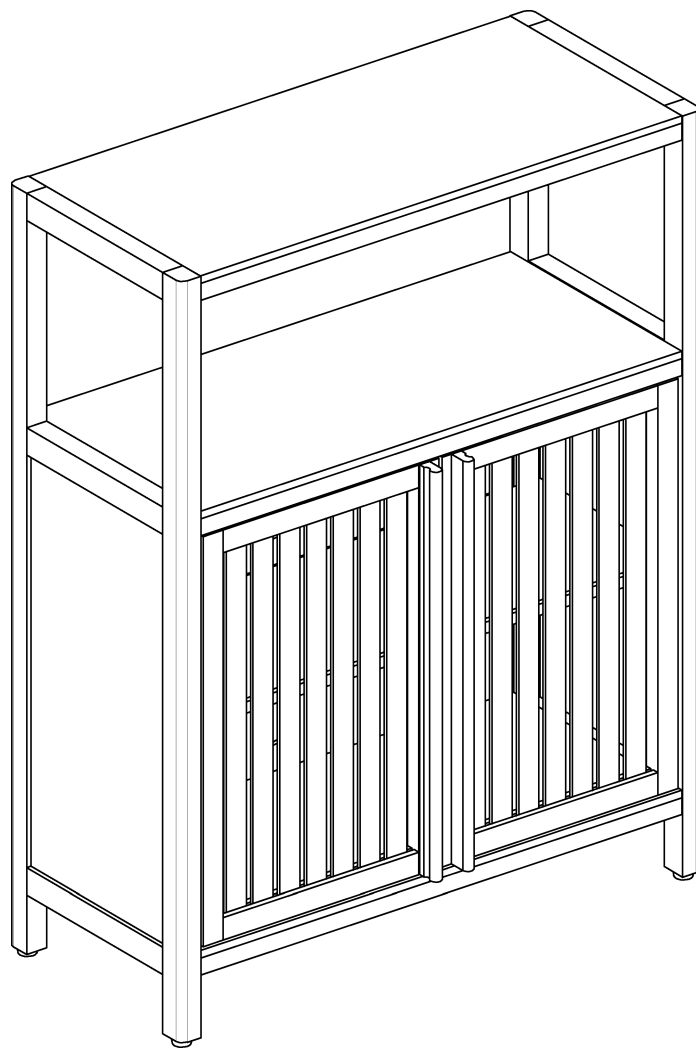

Getting started

Thank you for purchasing this product. Read the instructions and warnings carefully before use, to ensure safe and satisfactory operation of this product.



WARNING



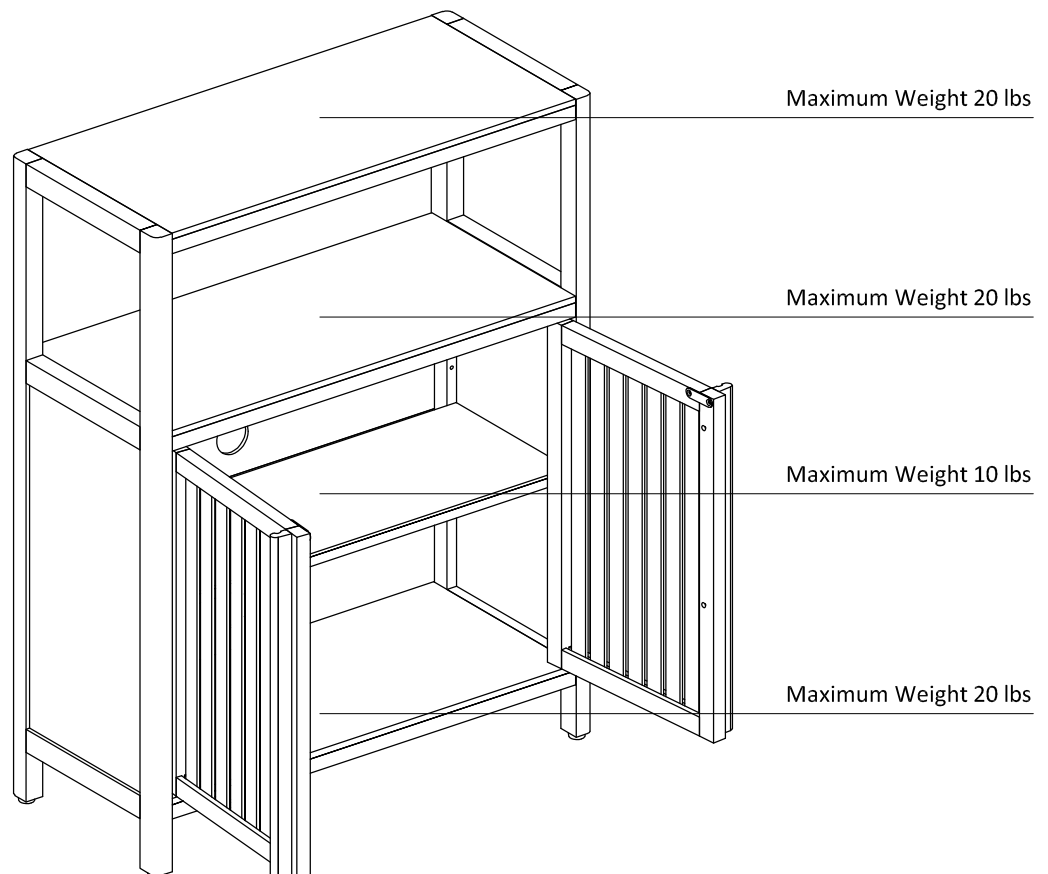
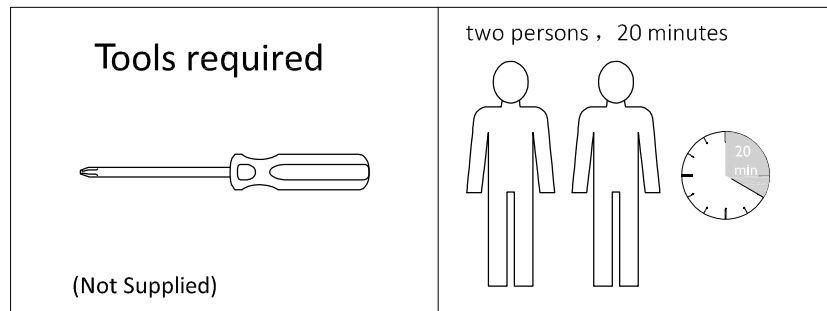

- Do not let any sharp objects touch or rub the surface of the product.
- When assembling, do not let children play around the working area.
- Please confirm all parts are correct before starting the assembly process.
- Do not tighten all bolts and screws completely until the entire unit has been assembled and set up.
- **DO NOT USE POWER TOOLS.**
- Power tools can over tighten screws and strip threads.
- For each screw:
 1. Tighten each screw until you meet resistance.
 2. Tighten one additional full rotation. **DO NOT OVER TIGHTEN.**

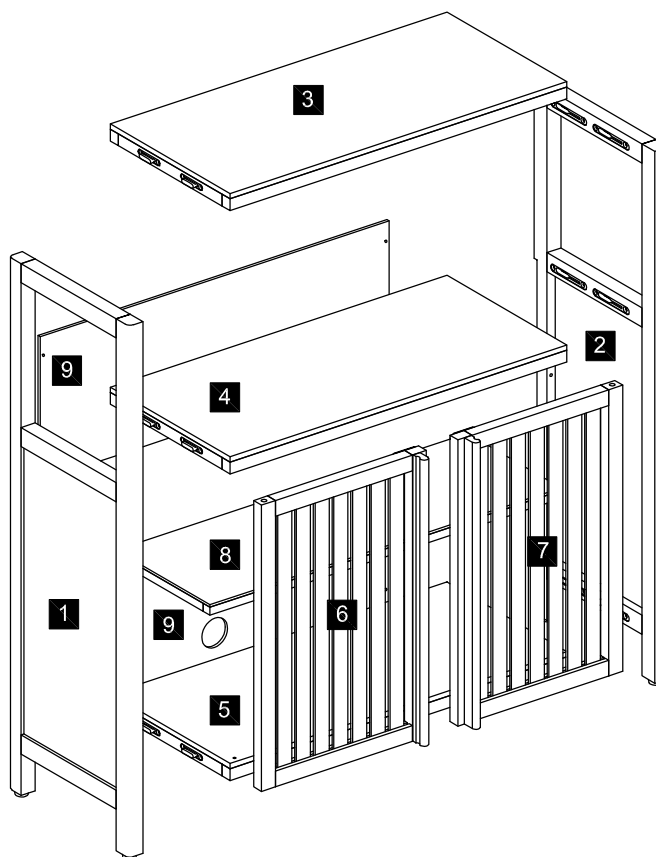

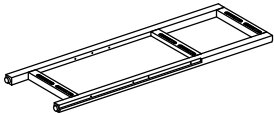
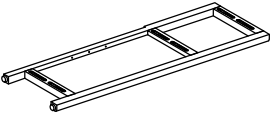
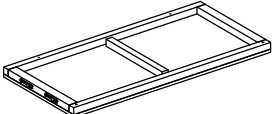
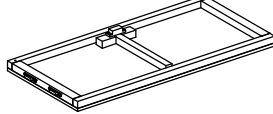
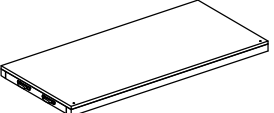
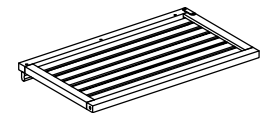
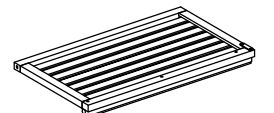
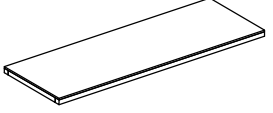
Fittings and parts checklist

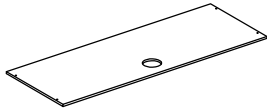
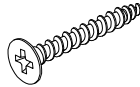

No.	Picture	Name	Qty	No.	Picture	Name	Qty
1		Left side frame	1	2		Right side frame	1
3		Top panel	1	4		Fixed shelf	1
5		Bottom panel	1	6		Left door	1
7		Right door	1	8		Adjustable shelf	1

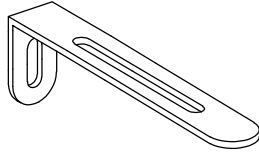
No.	Picture	Name	Qty	No.	Picture	Name	Qty
9		Back panel	2	A		Screw	8
B		Shelf Support	4	C		Pin	5 (One spare)
D		Screw	2	E		Metal 'L' Bracket	2

Product assembly

Step 1

Parts, fittings and tools

- 1
- 2
- 3
- 4
- 5

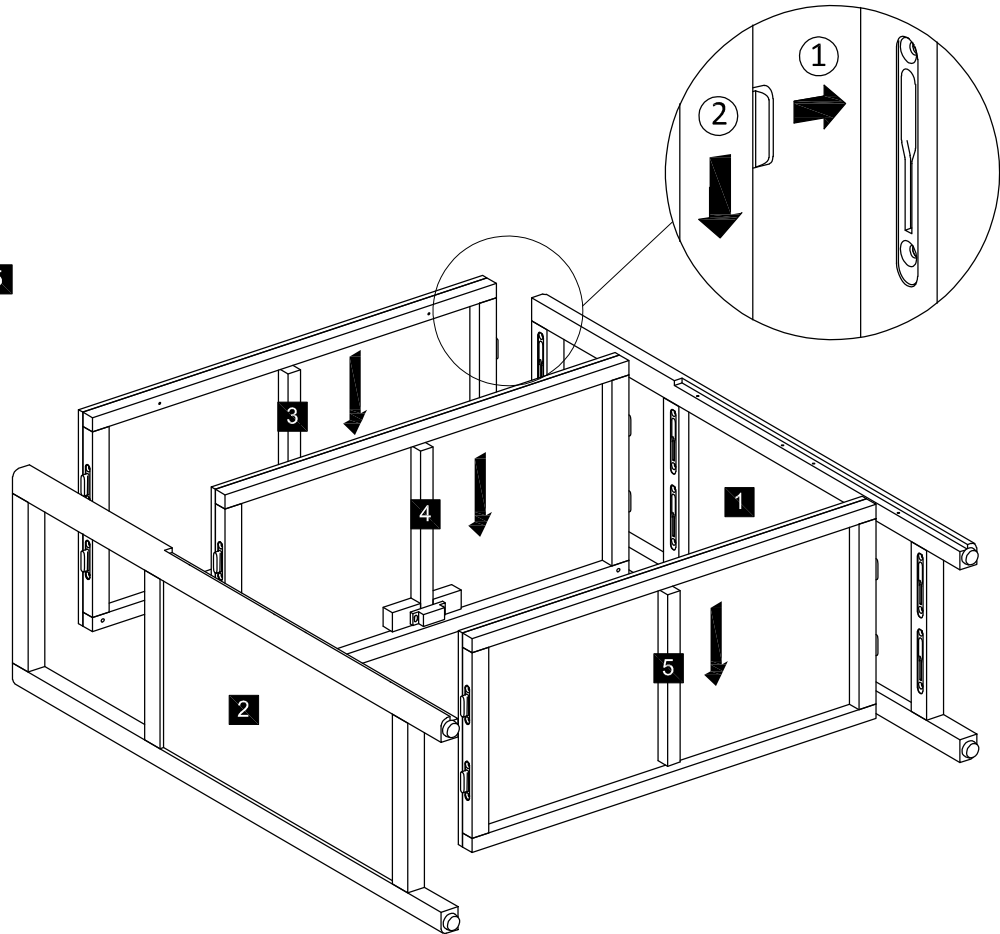

Step 2

Parts, fittings and tools

- 1
- 2
- 9
- A

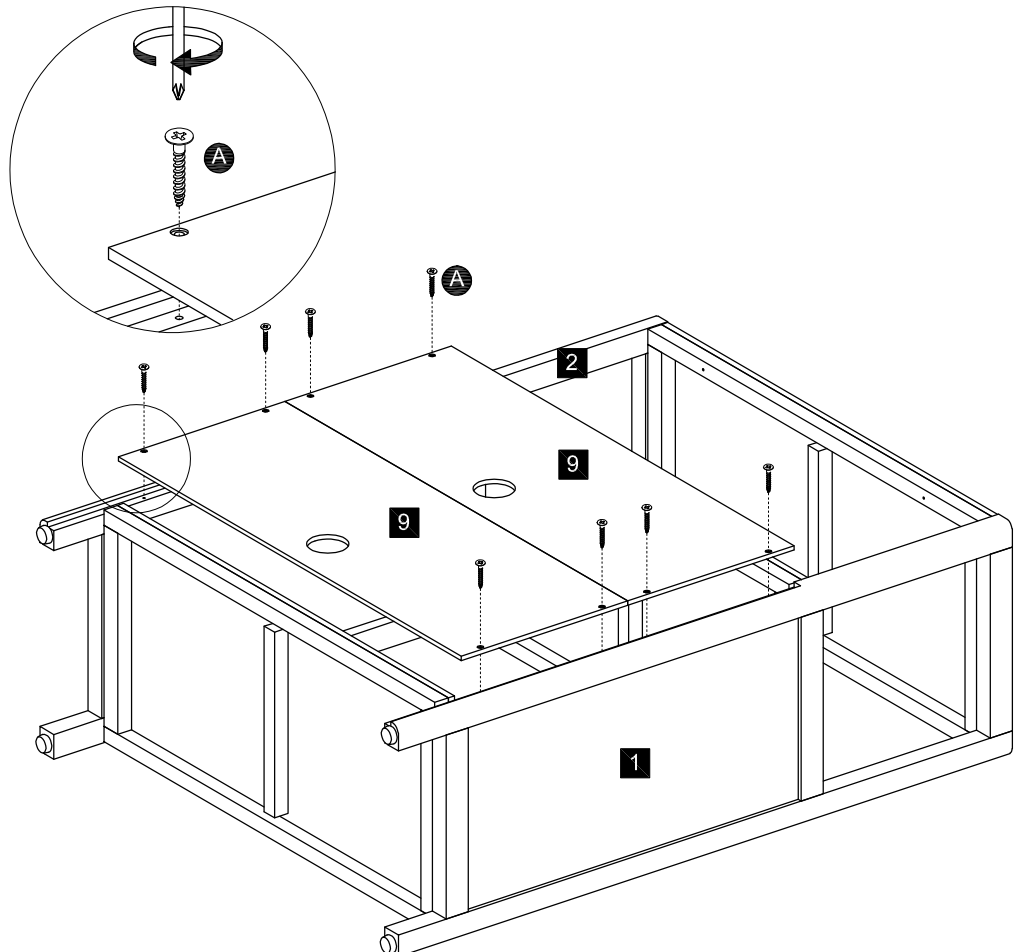
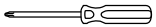

Step 3

Parts, fittings and tools

1 2 8 B

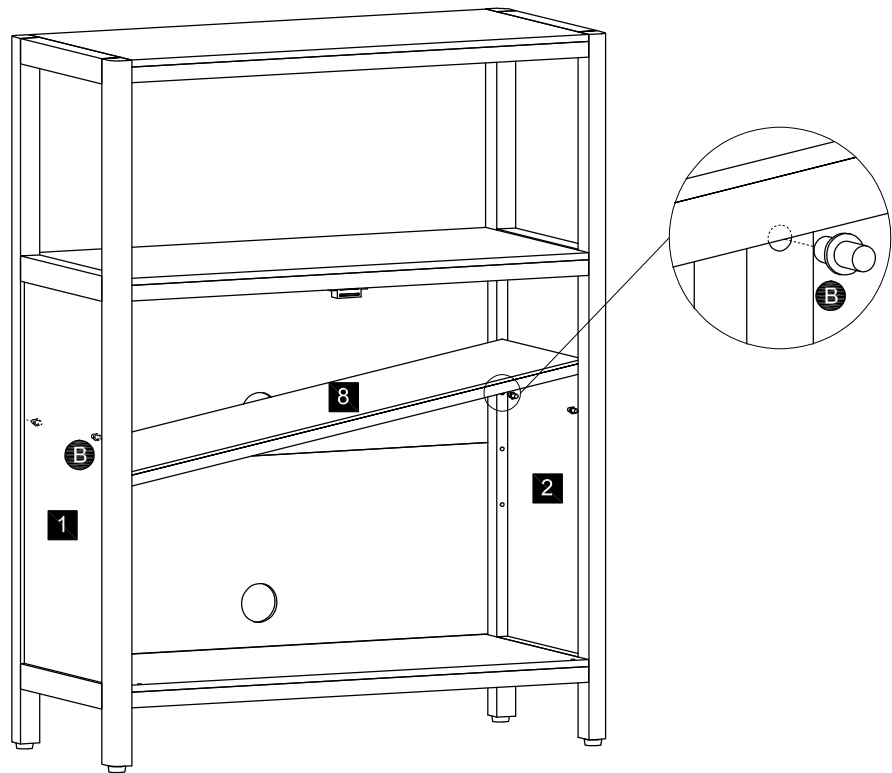

Step 4

Parts, fittings and tools

6 7 C

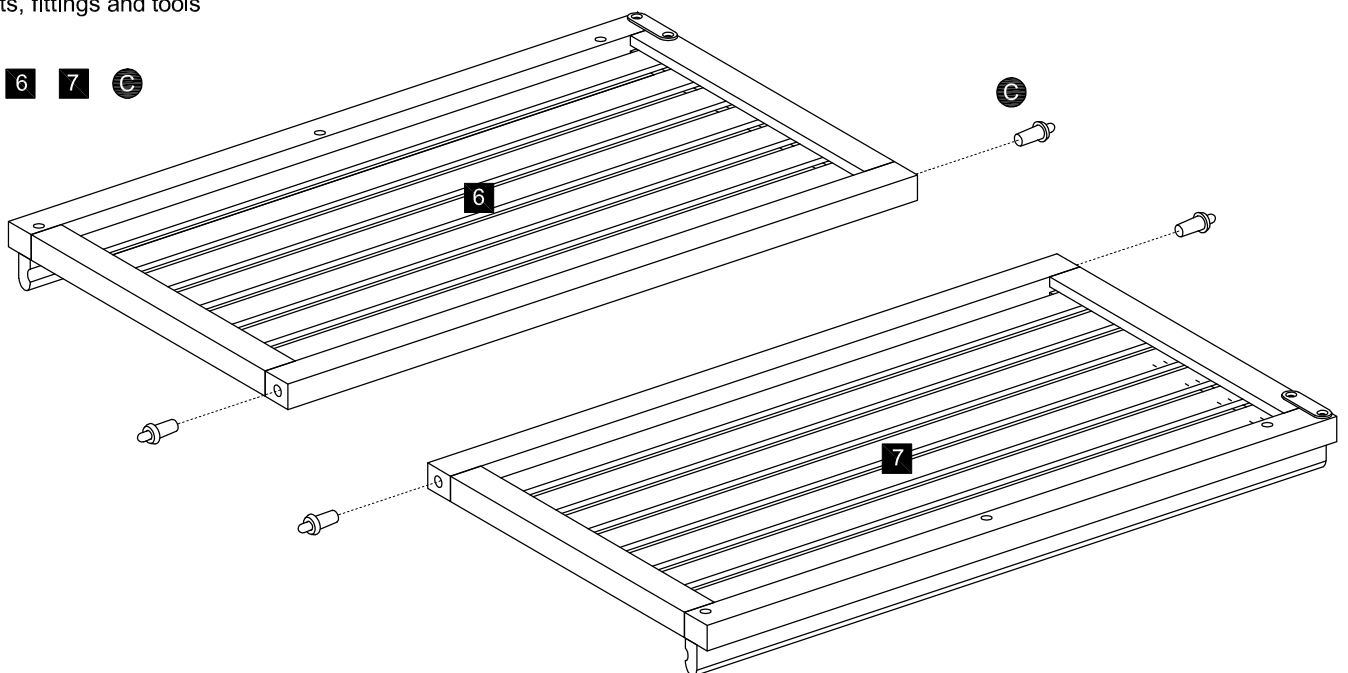

Step 5

Parts, fittings and tools

4 5 7 8

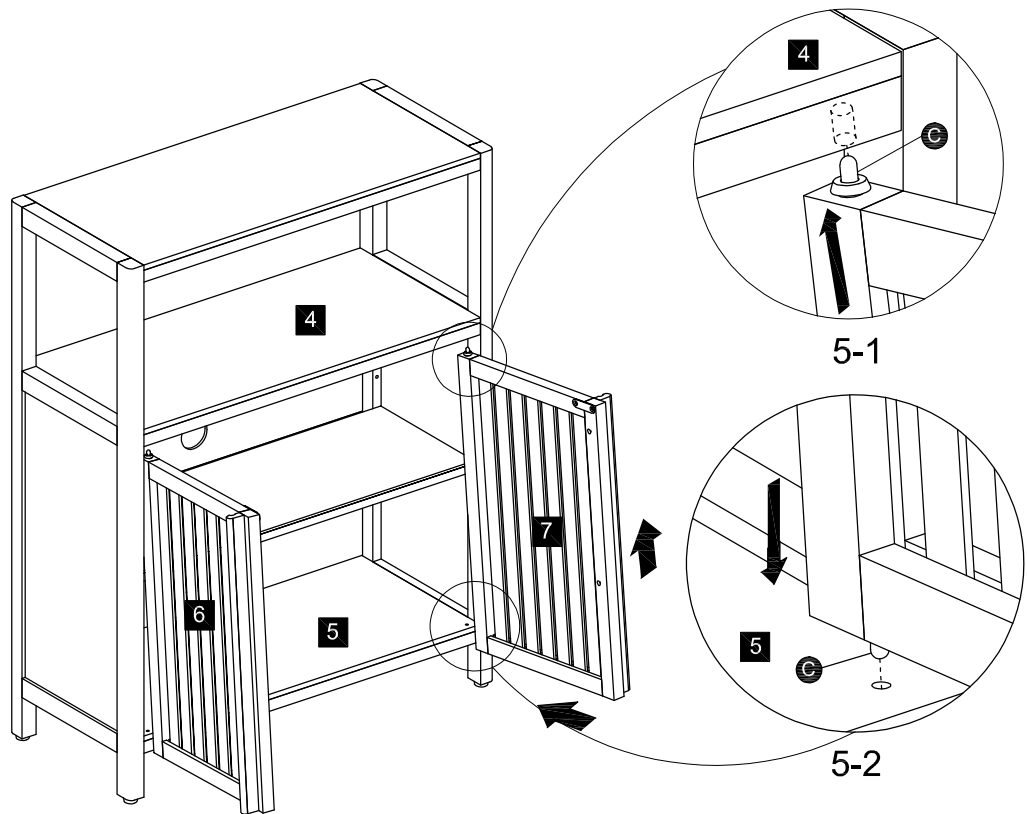

Step 6

Parts, fittings and tools

Use adjustable leveler if necessary.

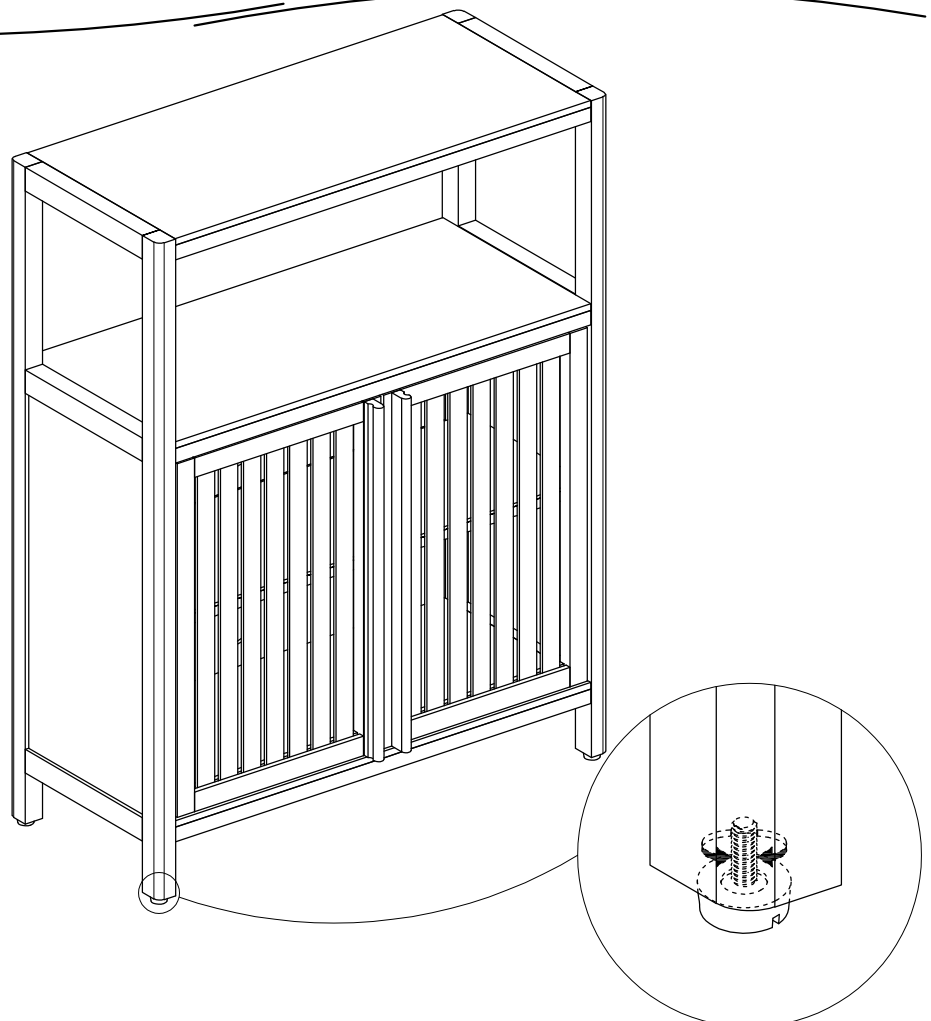

Step 7

Parts, fittings and tools

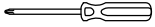

PLEASE NOTE: For your safety, to prevent the danger of this unit tipping over, it is important to choose a right anchor suitable for your wall and attach it properly.

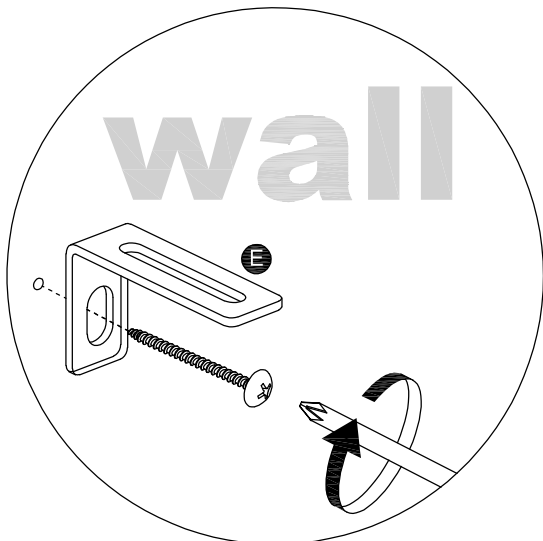
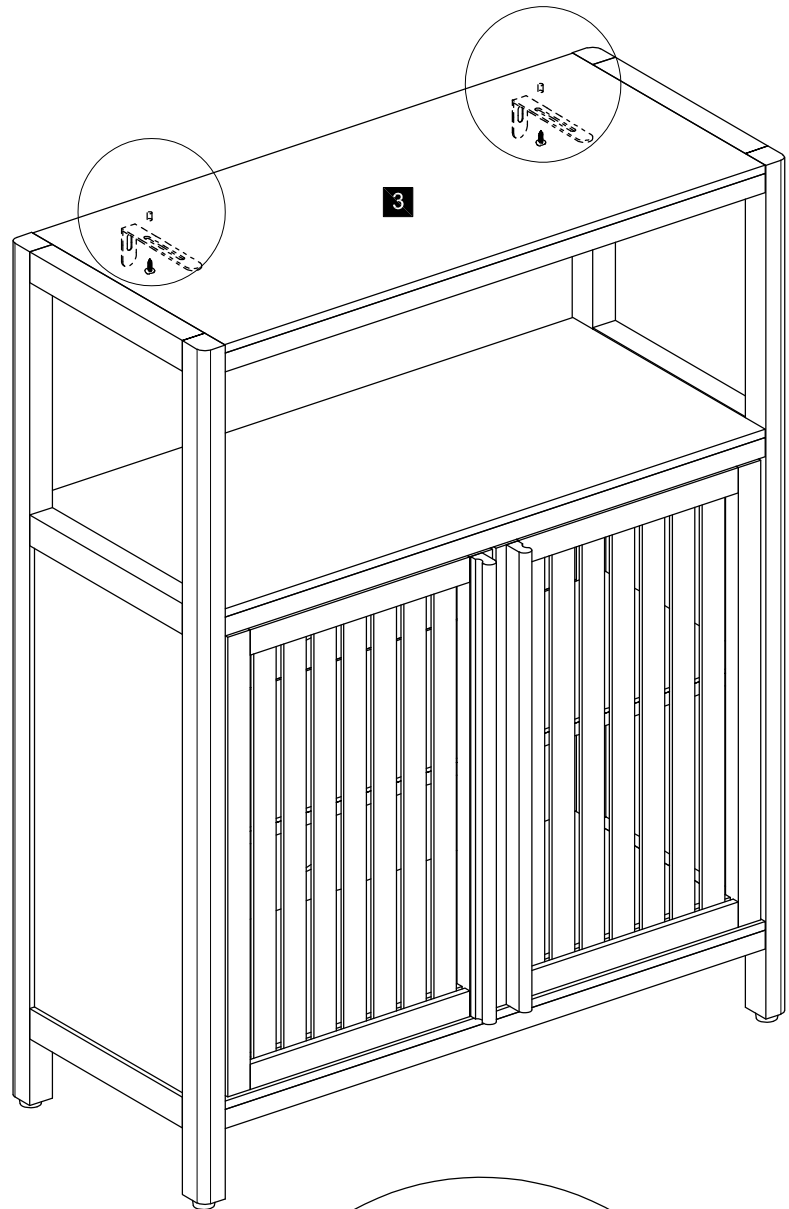

7-1

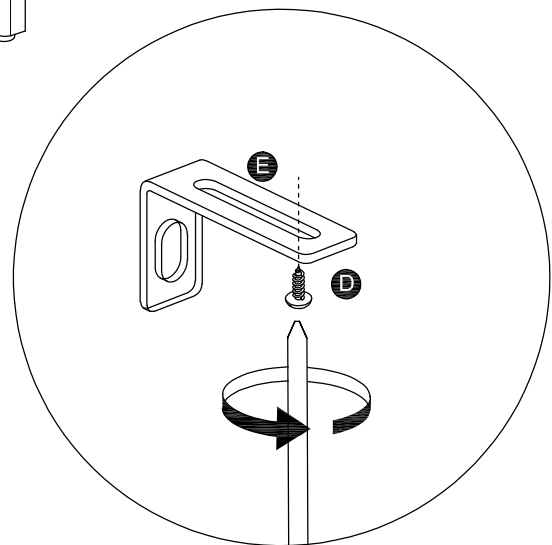

7-2