

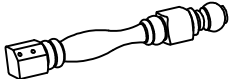



## ASSEMBLY INSTRUCTIONS

Thank you for purchasing this quality product. Be sure to check all packing material carefully for small parts, which may have come loose inside the carton during shipment. Identify and count all parts and compare with the HARDWARE LIST below.

### HARDWARE / PARTS LOCATION

D00511DT > Step 2 hardware > Inside red pack with red tape > Placed at corner inside carton.

NO.	PARTS LIST		Q'TY
A	Table Top		1 Pc
B	Leg		4 Pcs

NO.	HARDWARE LIST		Q'TY
1		Bolt (5/32" x 80 mm)	8Pcs
2		Flat Washer (5/32" x 19x2 mm)	8Pcs
3		Spring Washer (5/32" x 9/16")	8Pcs
4		Allen Key 4 mm	1Pc

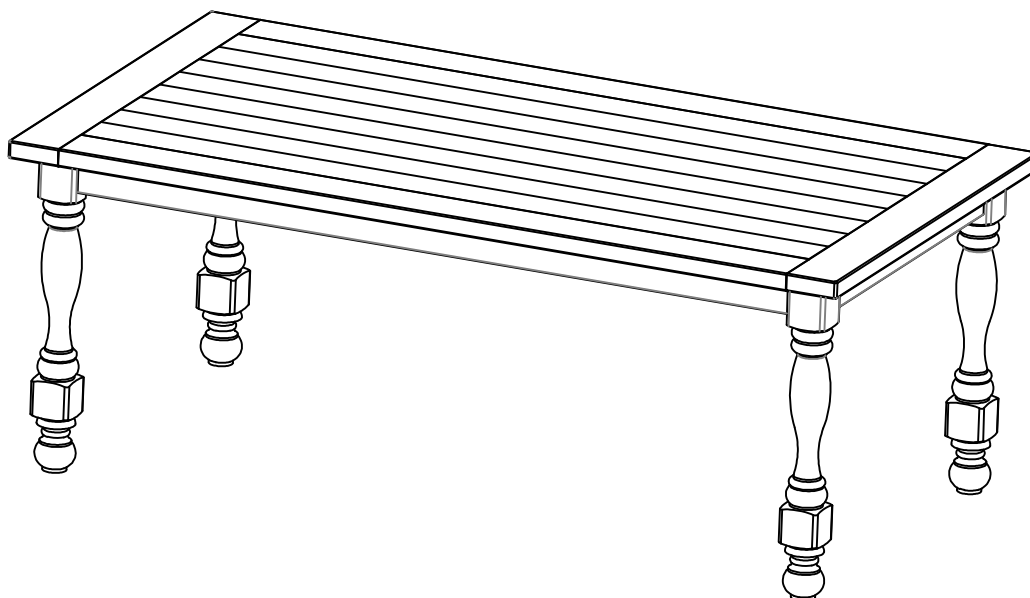

Note: Please DO NOT fully tighten all screws and bolts until the entire item is completely assembled

# ASSEMBLY INSTRUCTIONS

## STEP 1

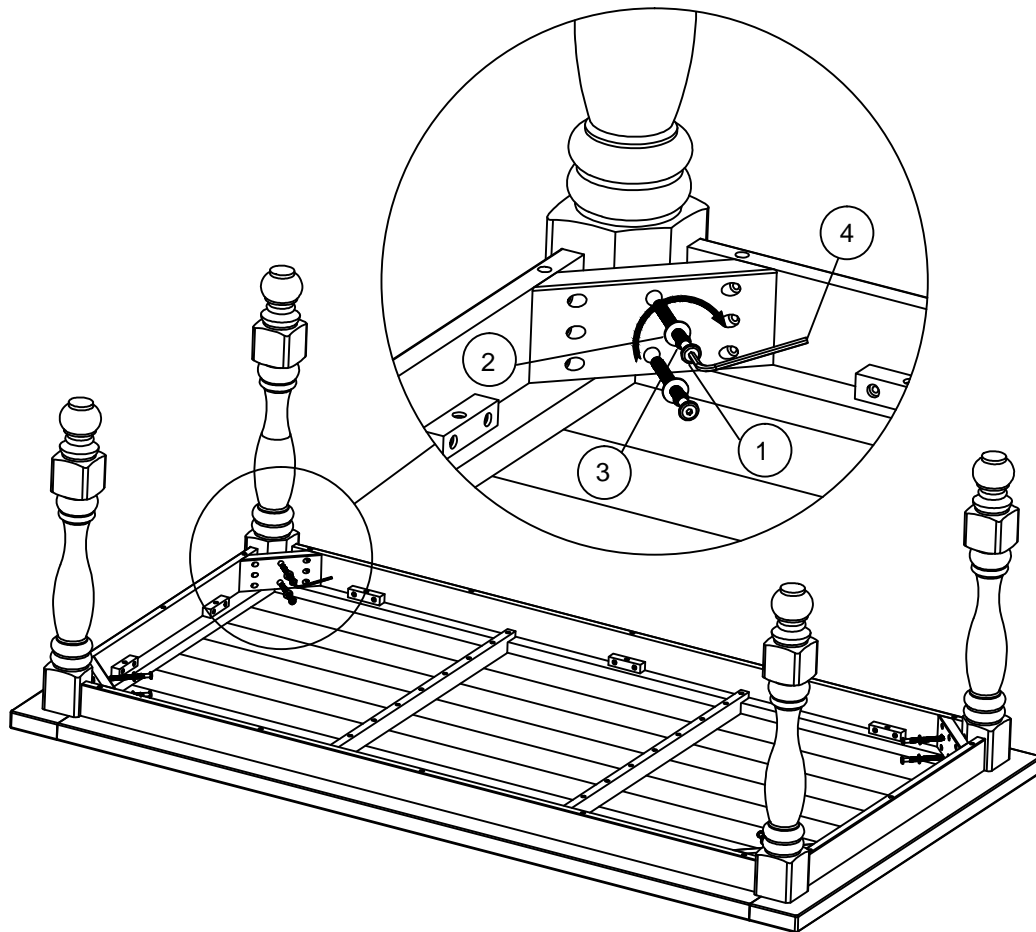
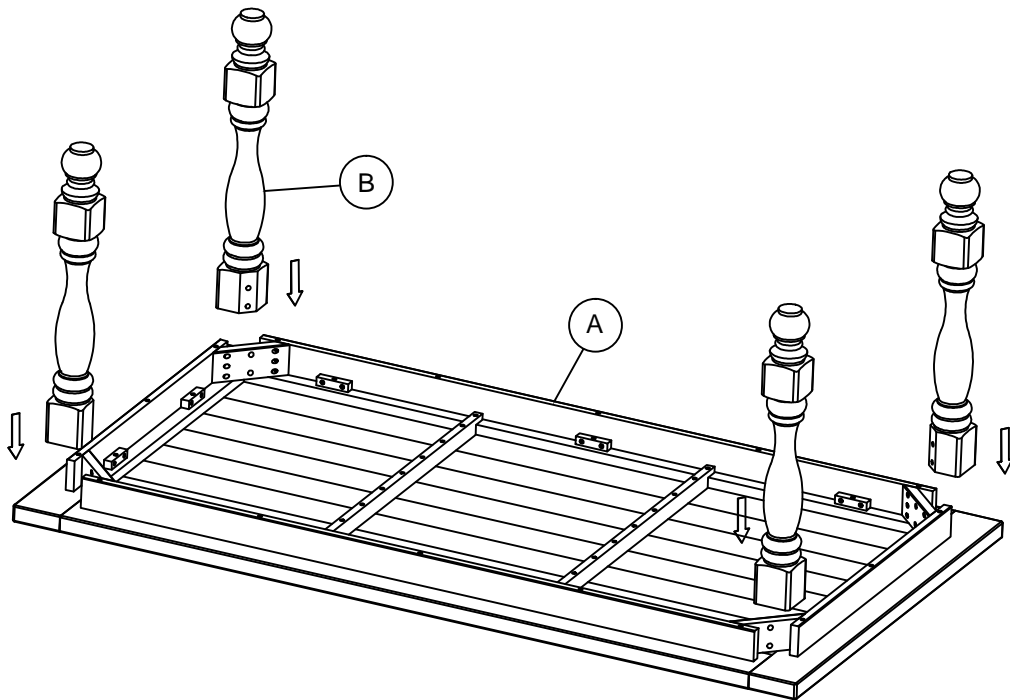

Note: Please DO NOT fully tighten all screws and bolts until the entire item is completely assembled

## ASSEMBLY INSTRUCTIONS

### STEP 2

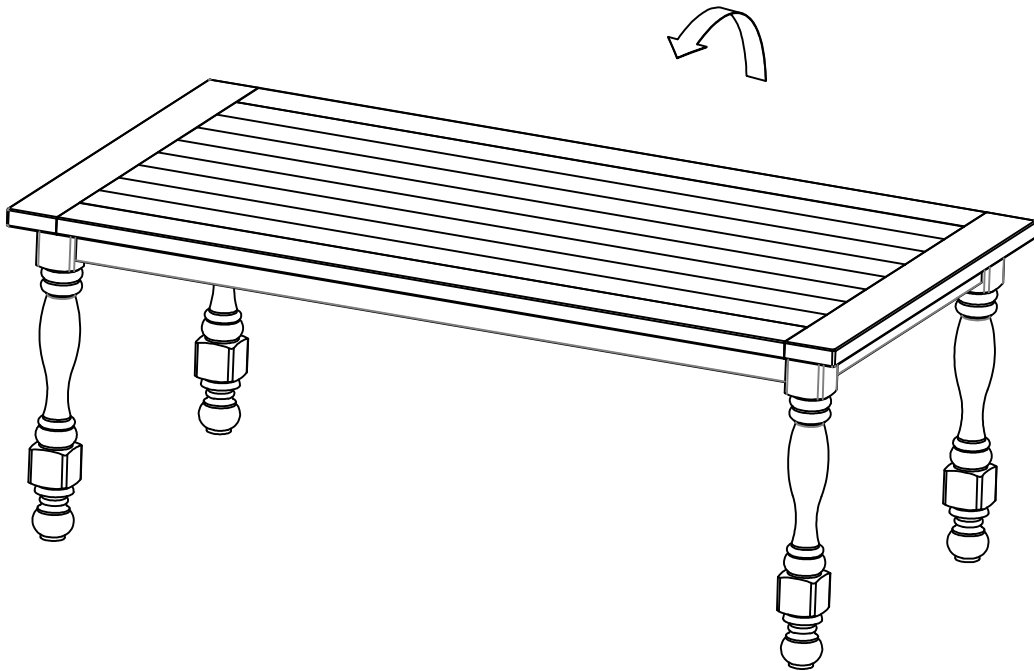

Note: Please DO NOT fully tighten all screws and bolts until the entire item is completely assembled