

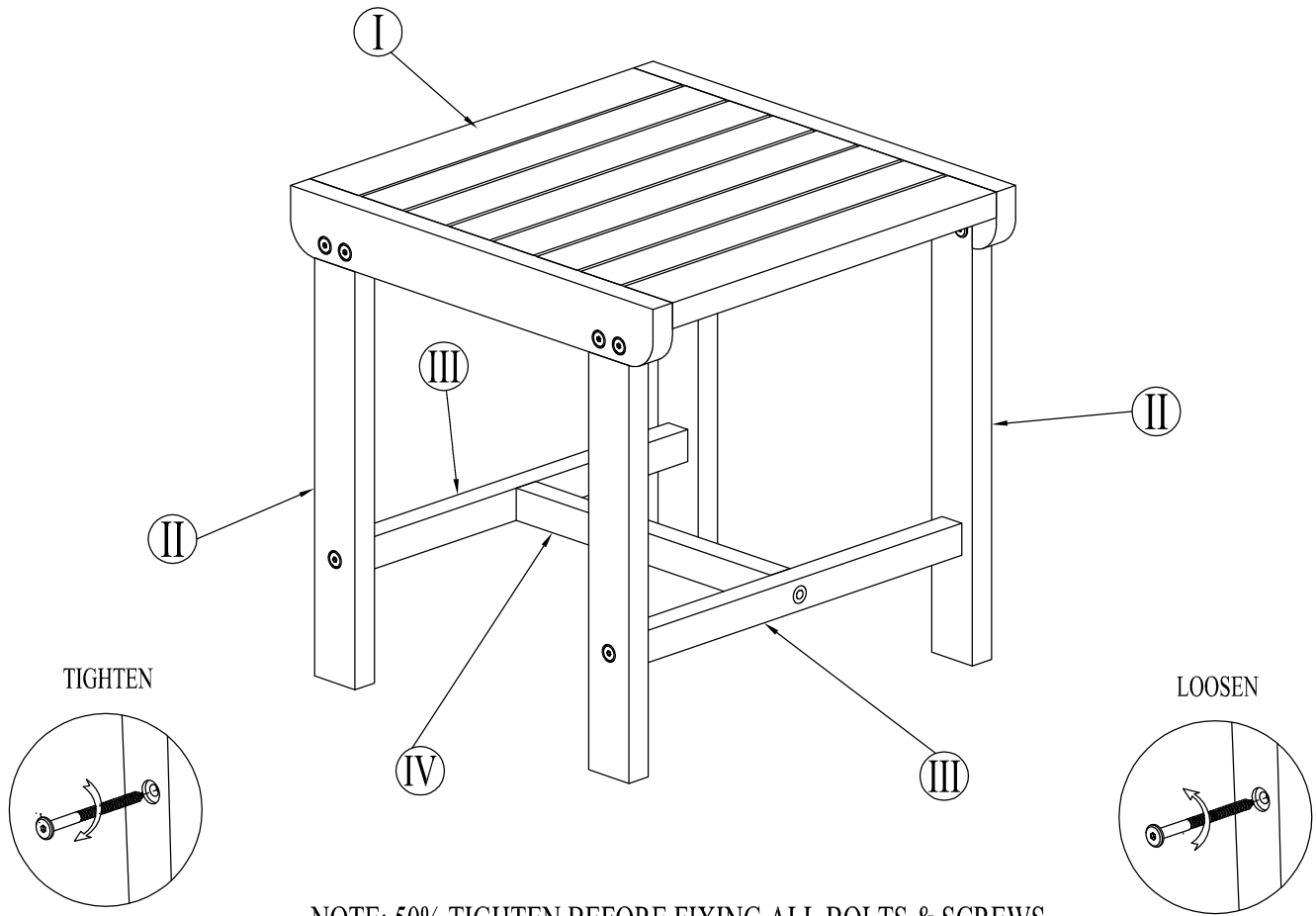

Maximum capacity : 40 kgs/88 Lbs







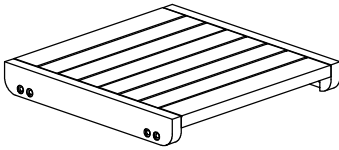

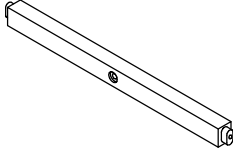
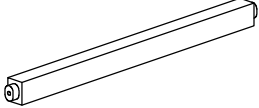
NOTE: 50% TIGHTEN BEFORE FIXING ALL BOLTS & SCREWS

COMPONENTS LIST

<p>Ⅰ</p>  <p>Q'TY 1</p>	<p>Ⅱ</p>  <p>Q'TY 4</p>	<p>Ⅲ</p>  <p>Q'TY 2</p>	<p>Ⅳ</p>  <p>Q'TY 1</p>
---	--	---	--

HARDWARE LIST

A		6	F - Screw 7x50	C		8	Sleeve nut
B		8	Bolt 6x15	D		2	Allen Key

Step 1

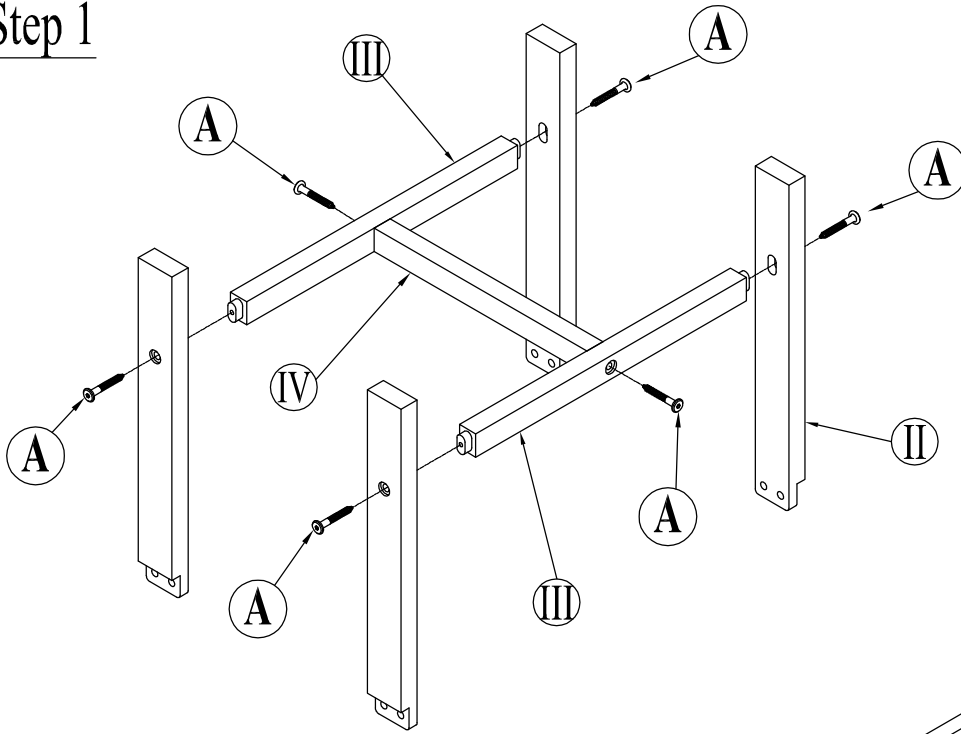

Step 2

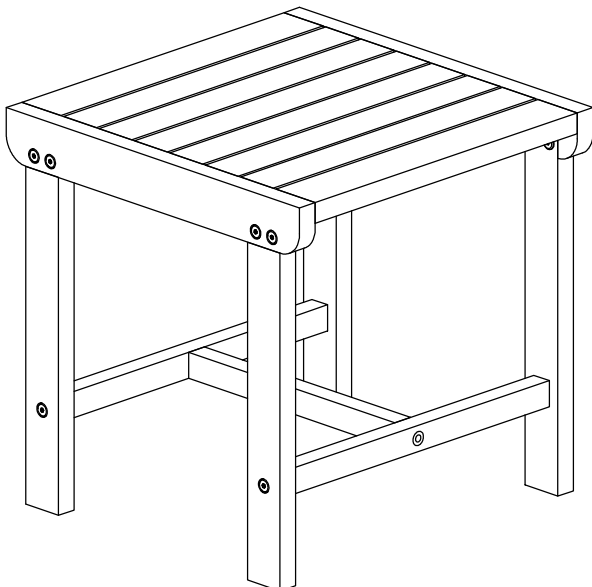
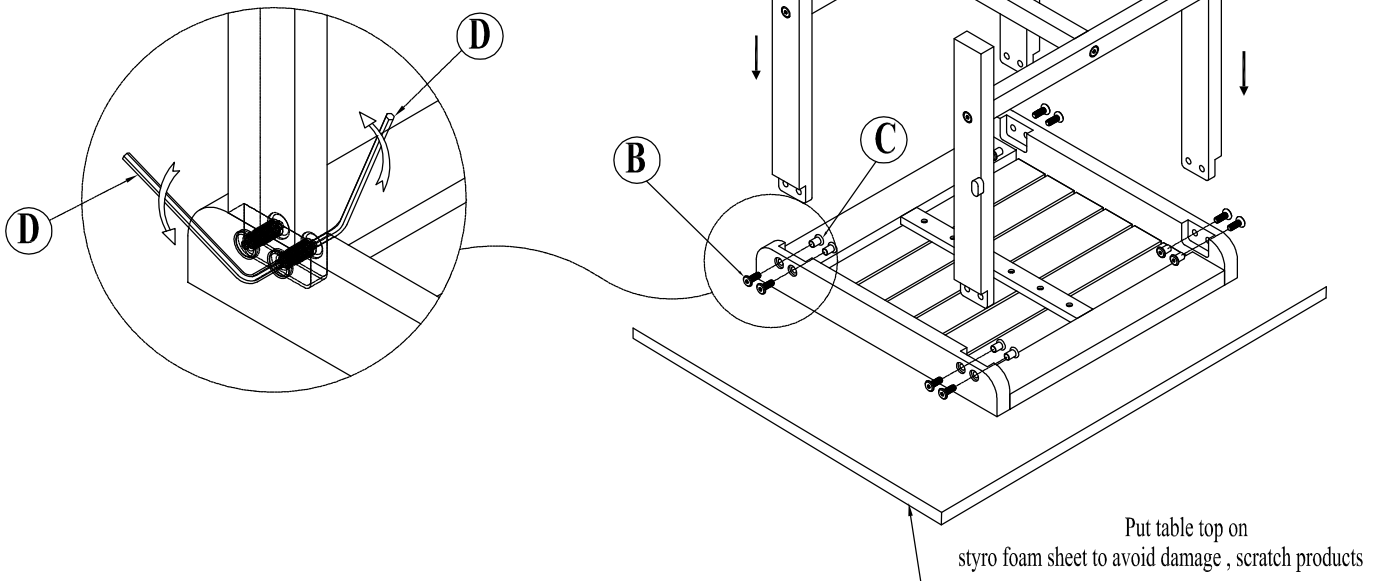

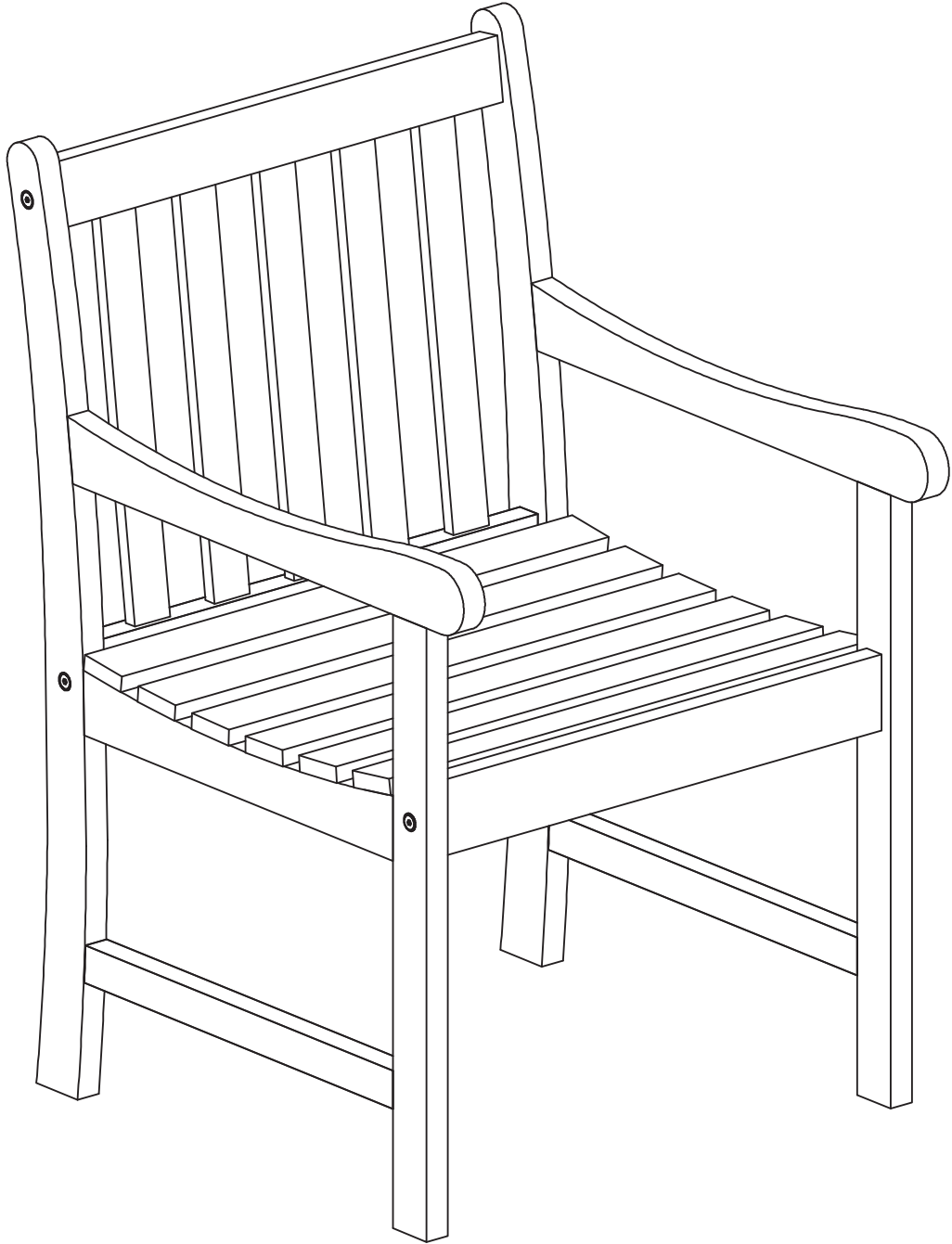

Maximum capacity : 110 kgs/242 Lbs



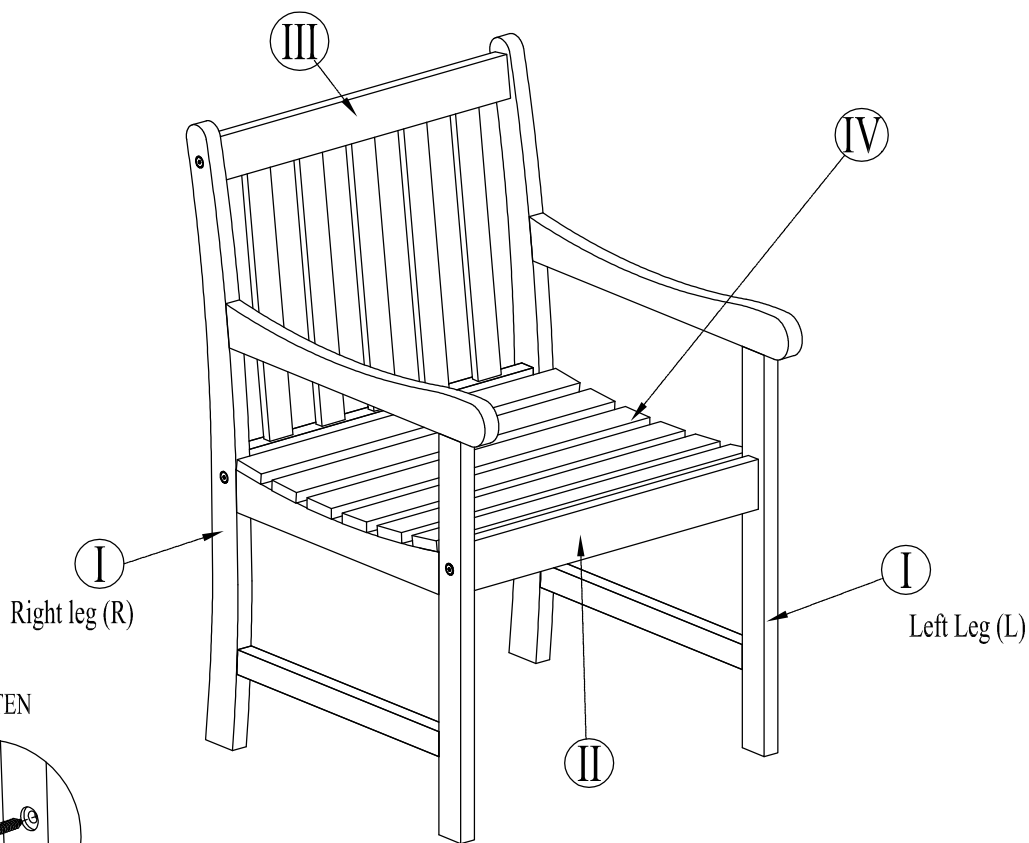

Right leg (R)

Left Leg (L)

TIGHTEN

LOOSEN

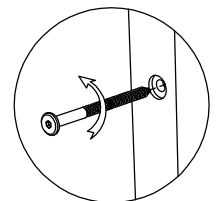
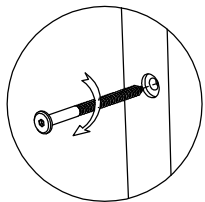

NOTE: 50% TIGHTEN BEFORE FIXING ALL BOLTS & SCREWS

COMPONENTS LIST

<p>I</p> <p>Right leg (R) Left Leg (L)</p> <p>Q'TY 2</p>	<p>II</p> <p>Q'TY 1</p>	<p>IV</p> <p>Q'TY 1</p>
<p>III</p> <p>Q'TY 1</p>		

HARDWARE LIST

A		6	Screw 7 x 70				
B		2	Screw 7x40	C		2	Allen Key

Step 1

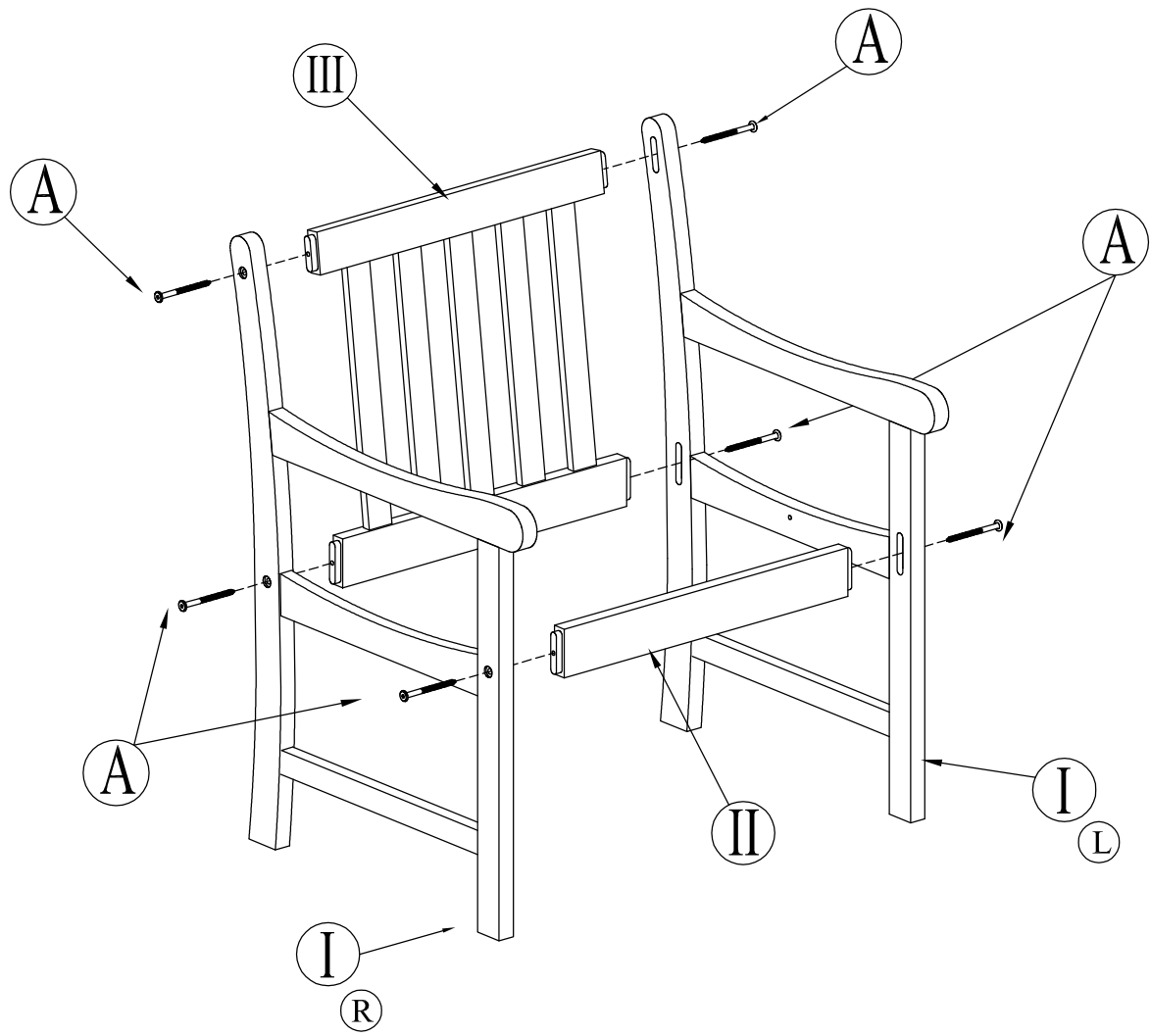

Step 2

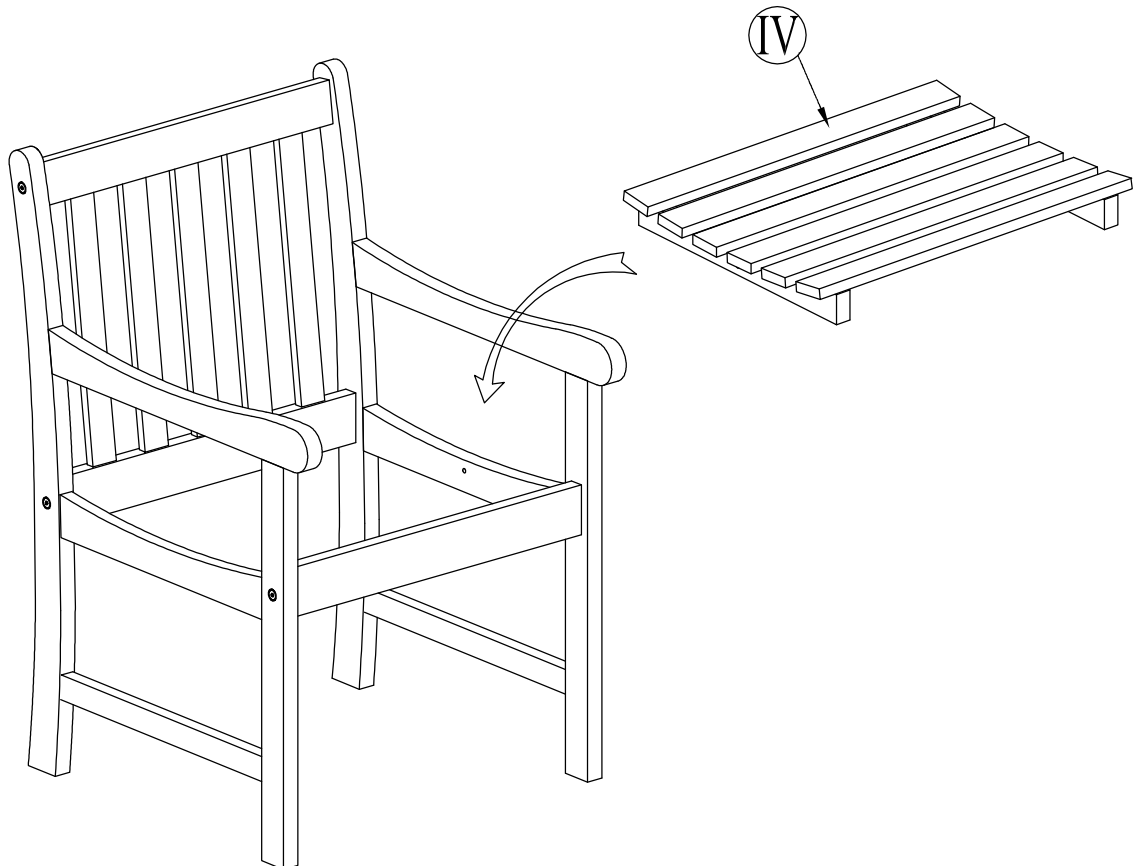

Step 3

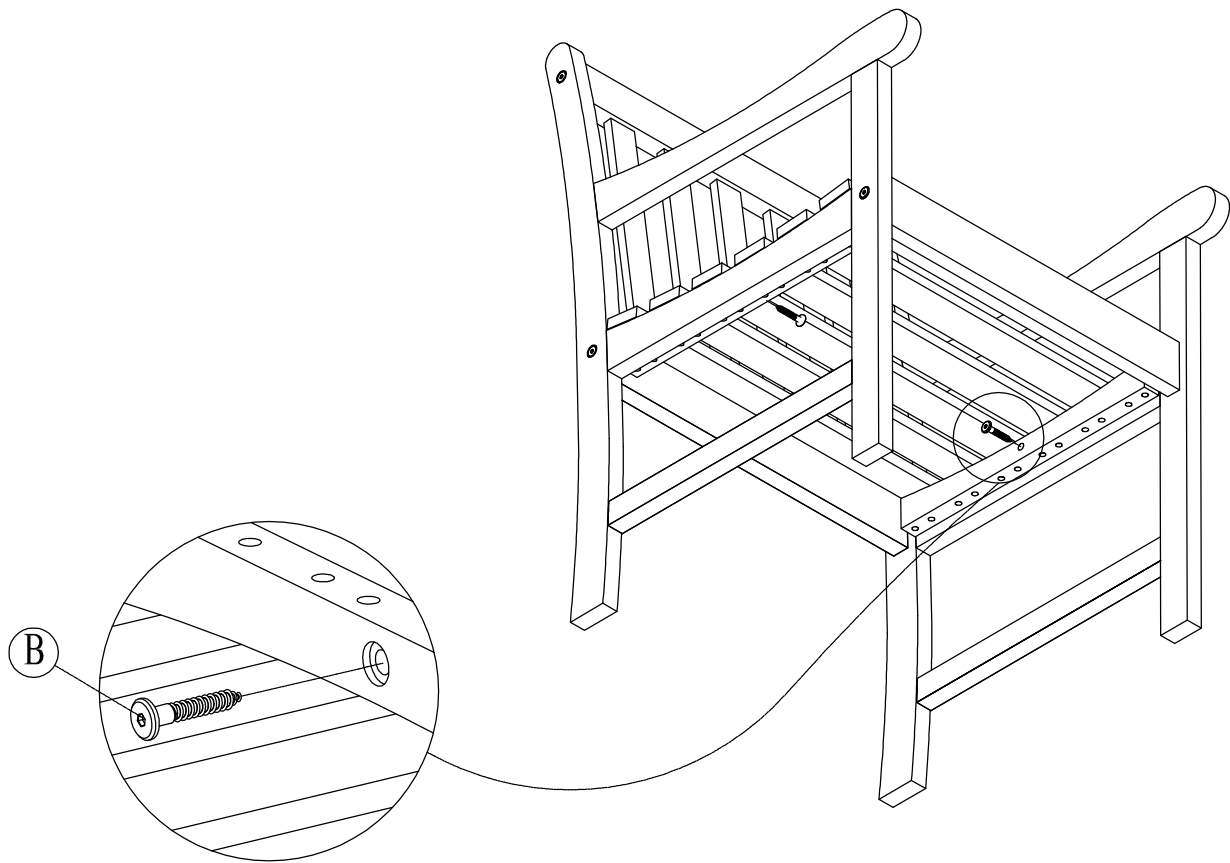

Step 4

