

ASSEMBLY INSTRUCTION

MODEL#WF003

Thank you for purchasing the quality product. Be sure to check all packing material carefully for small parts which may have come loose inside the carton during shipment. Separate, identify and count all parts and metal hardware. Compare with all parts list to be sure all parts are present. If any part(s) are missing or damaged, please contact your local furniture dealer. For efficient and speedy service, please indicate the model number and code letter of part(s) needed.

*****Do not fully tighten screws until fully assembled*****

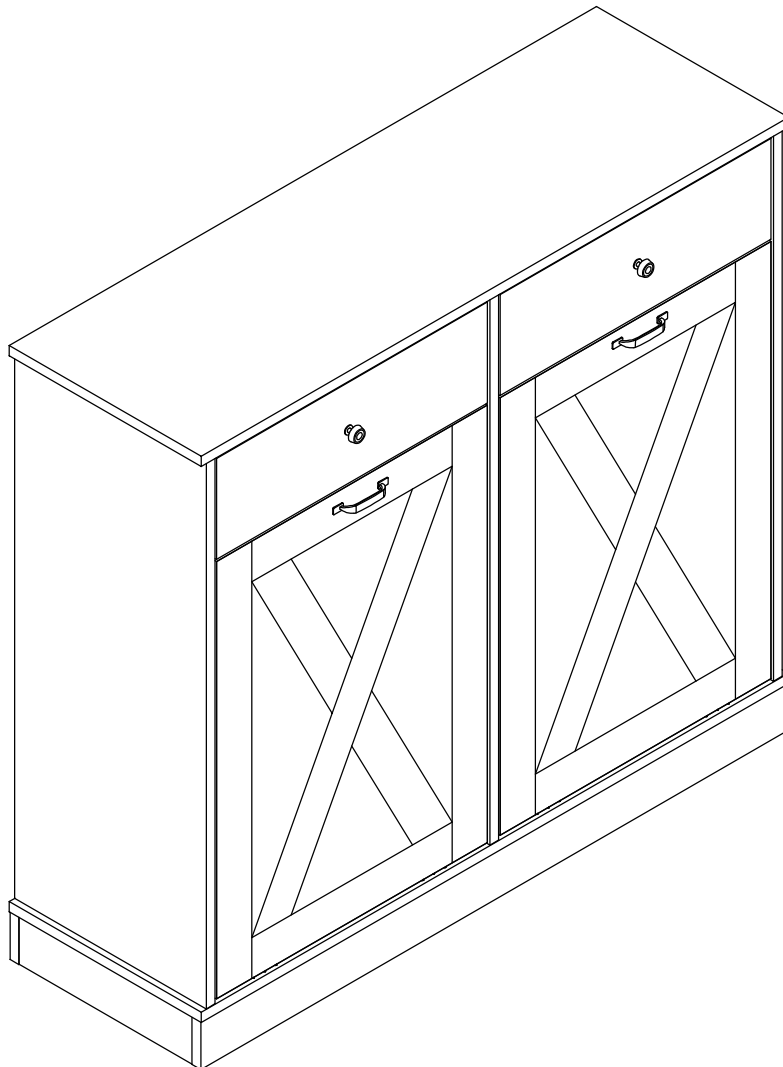

Attention:

*****Some number parts listed on the instruction sheet may not be in parts bag as they may already be assembled. Carefully check parts and packing materials prior to ordering replacements.**

General Assembly Guidelines

- I. Ensure that all parts and hardware are available before beginning assembly.
- II. Follow each step carefully to ensure the proper assembly of this product.
- III. Two people are recommended for ease in the assembly of this product.
- IV. The three main types of hardware used to assemble this product are: wood dowels, screws and bolts.
- V. A Phillips head screwdriver is required for the assembly of this product.

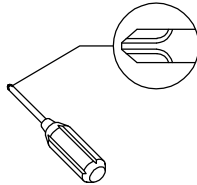



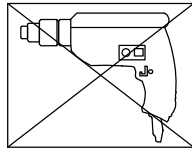



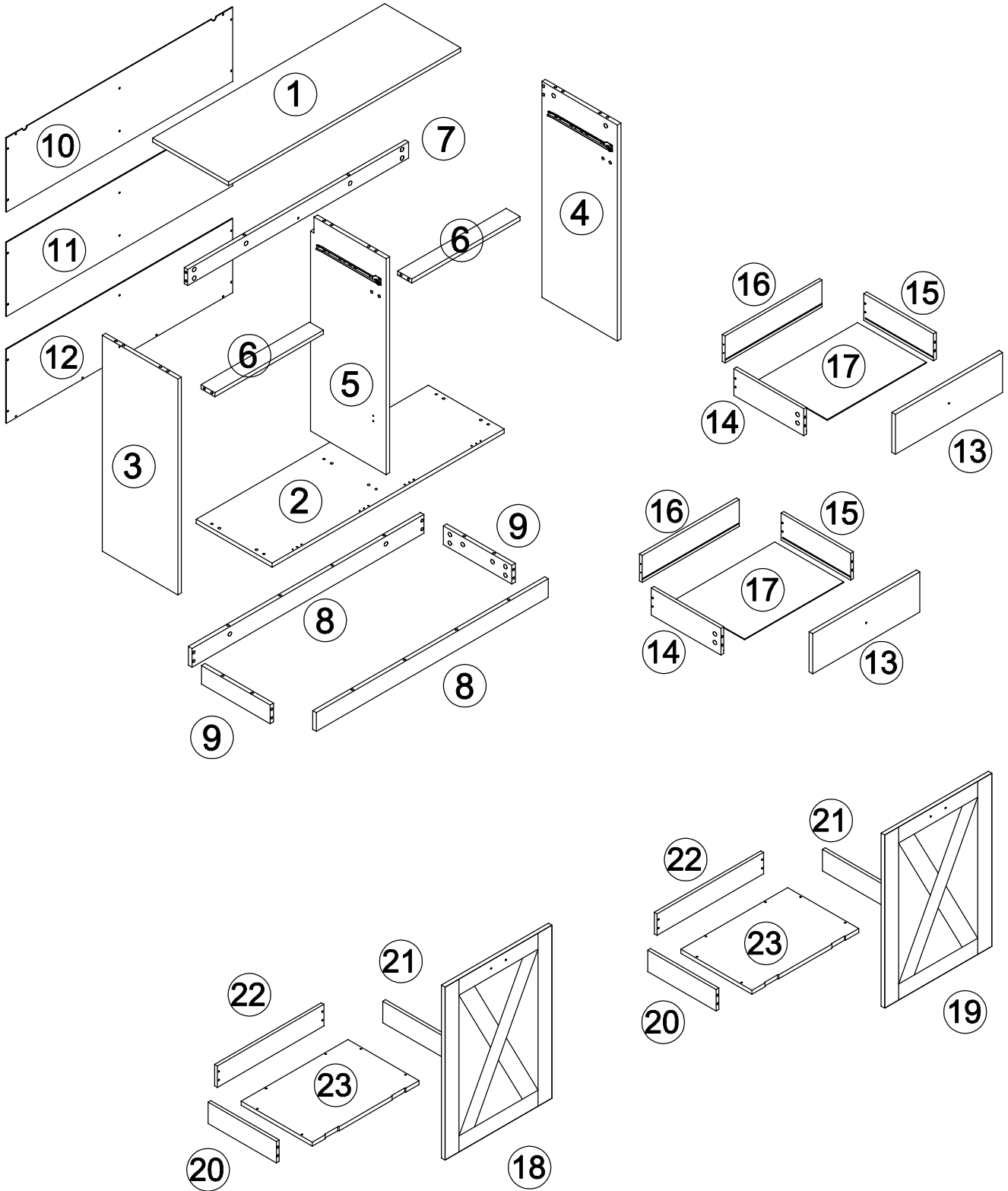









- VI. Power tools should not be used to assemble this product.



COMPONENT PARTS



Hardware List

A		Ø8x30mm	Wooden dowel	16 pcs
B		Ø6x35mm	Cam bolt	36 pcs
C		Ø15x12mm	Cam lock	36 pcs
D		Ø6x50mm	Screw	6 pcs
E		4mm	Allen Key	1 pcs
F			Handle	2 pcs
G		Ø4x20mm	Screw	6 pcs
H			Hanging brace	1 pcs
J			Hanging brace	1 pcs
K		Ø3.5x12mm	Bolt	40 pcs
L			Hinge	4 pcs
M		M4x30mm	Screw	29 pcs
N			Handle	2 pcs
O		Ø3.5x12mm	Screw	26 pcs
P		Ø6x32mm	Cam bolt	16 pcs
Q		Ø15x9mm	Cam lock	16 pcs
R				2 pcs

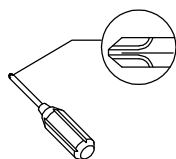

Philips head screwdriver required for assembly
(not included)

*The hardware quantities listed above are required for proper assembly.
Some extra hardware may also have been included.*

Step 1

B x 12

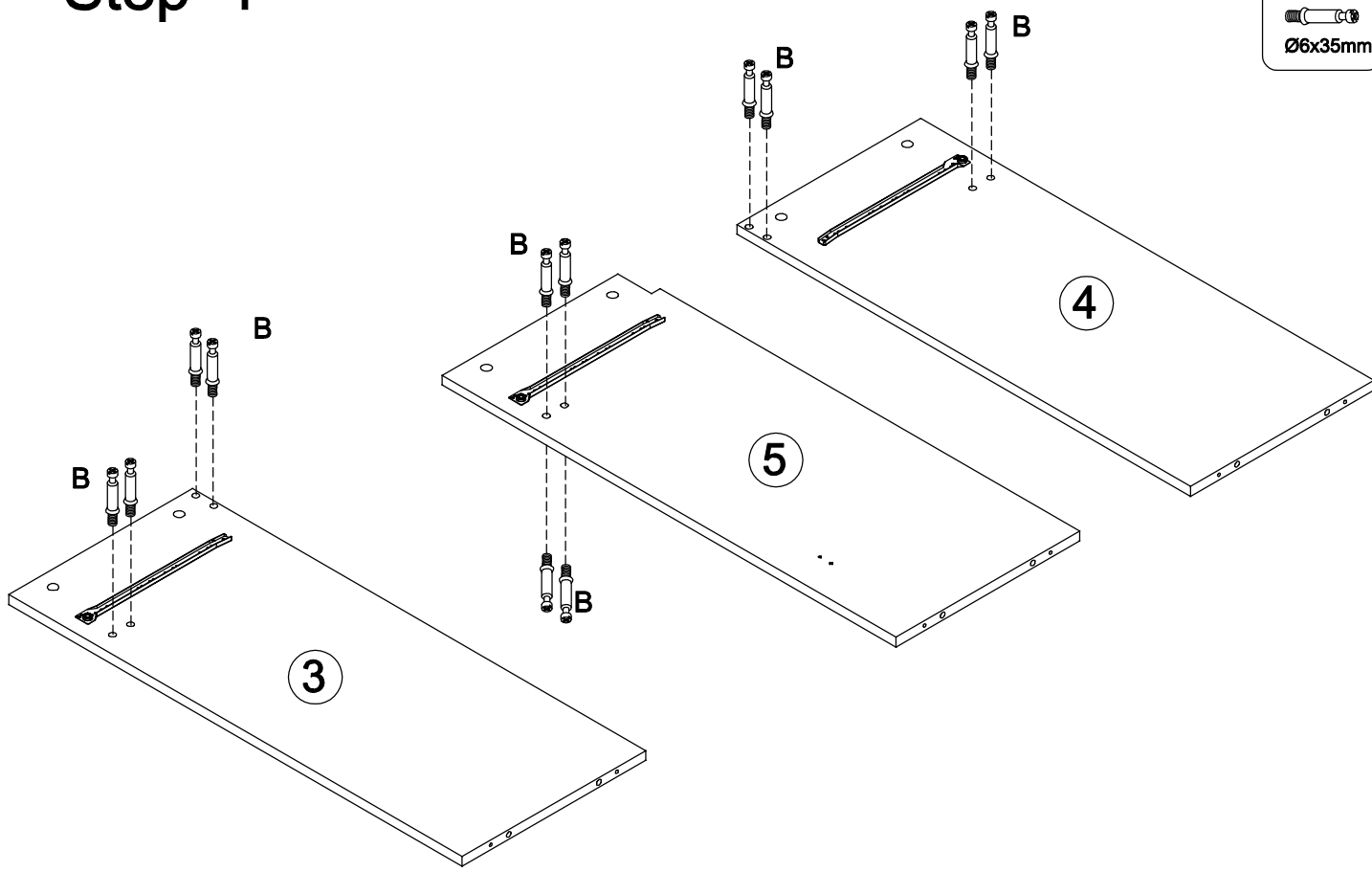
Ø6x35mm



Step 2

C x 12

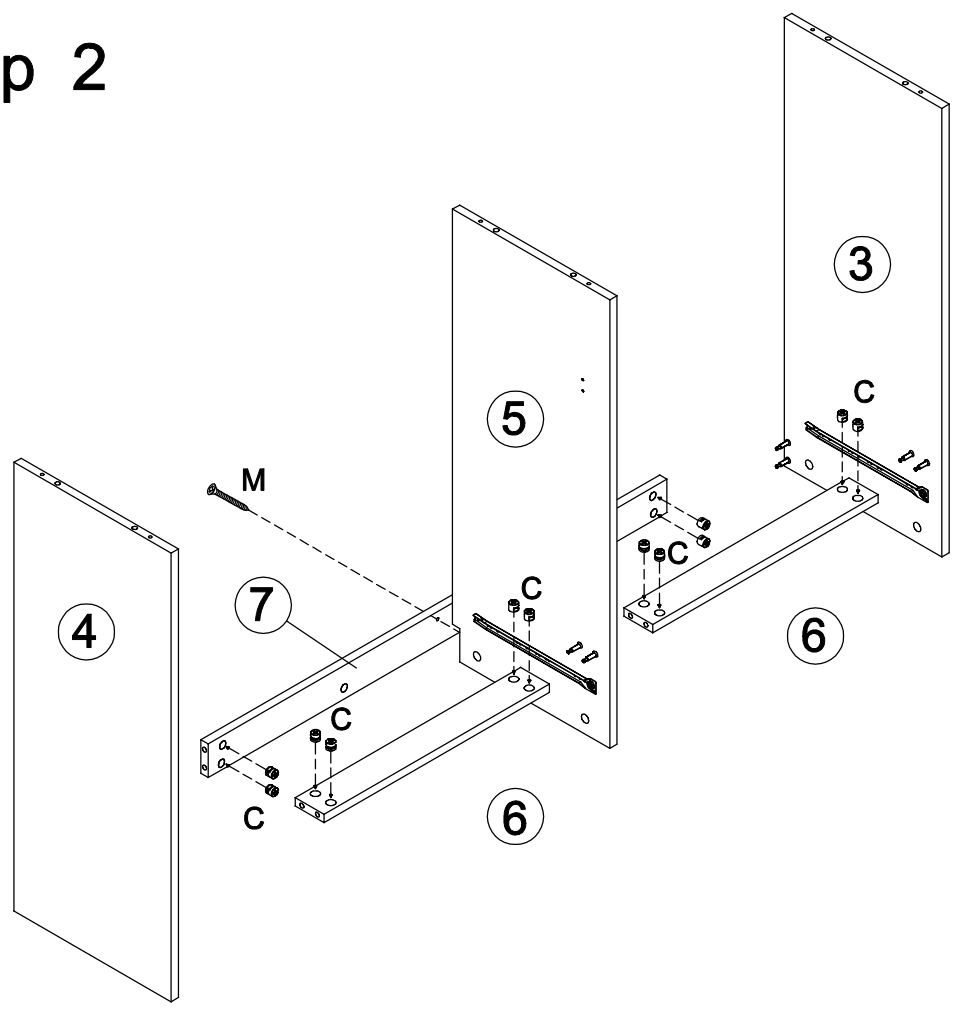
Ø15x12mm

M x 1

M4x30mm

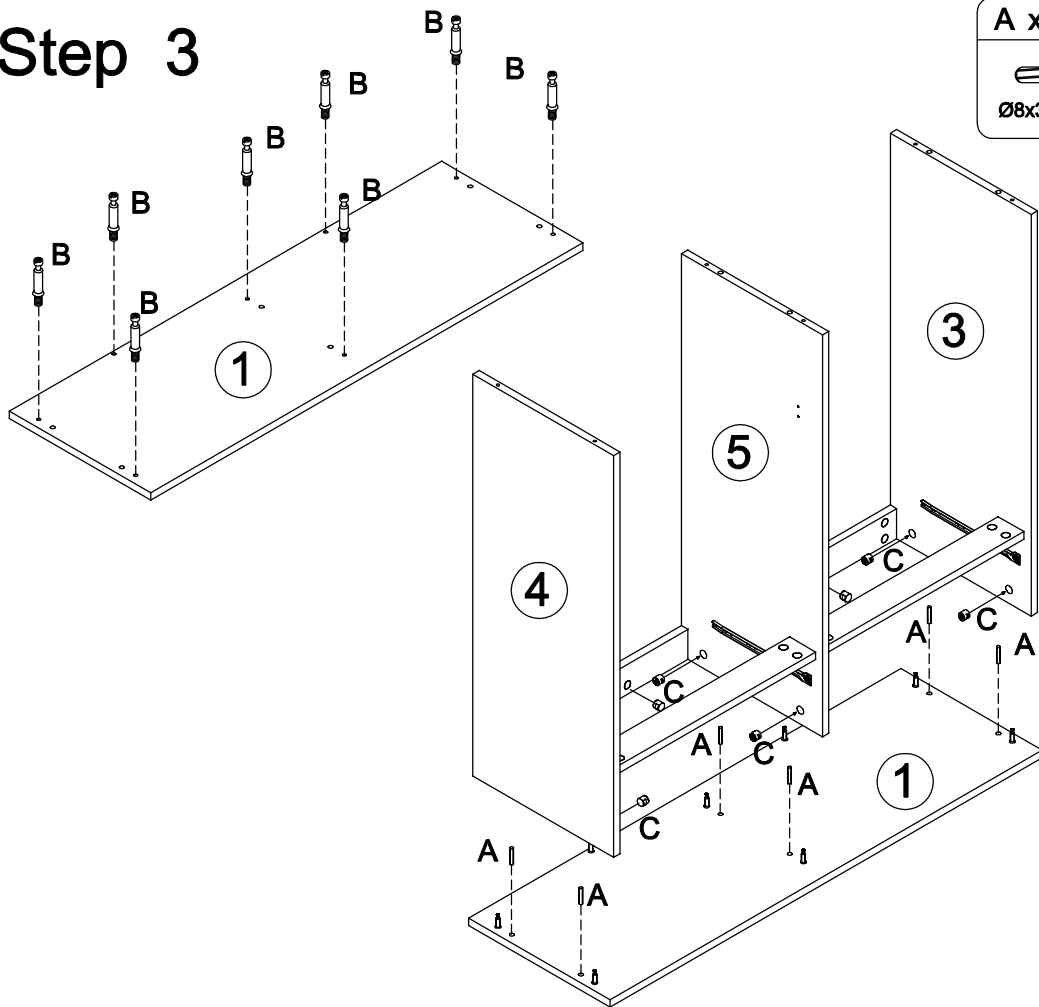

Step 3



A x 6

 Ø8x30mm

B x 8

 Ø6x35mm

C x 8

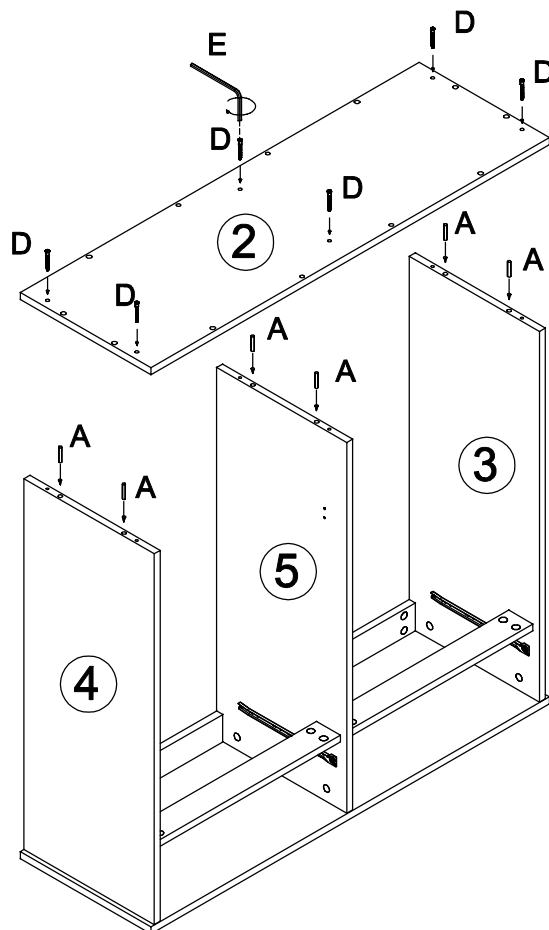
 Ø15x12mm

Step 4





A x 6

 Ø8x30mm

D x 6

 Ø6x50mm

E x 1

 4mm

Step 5

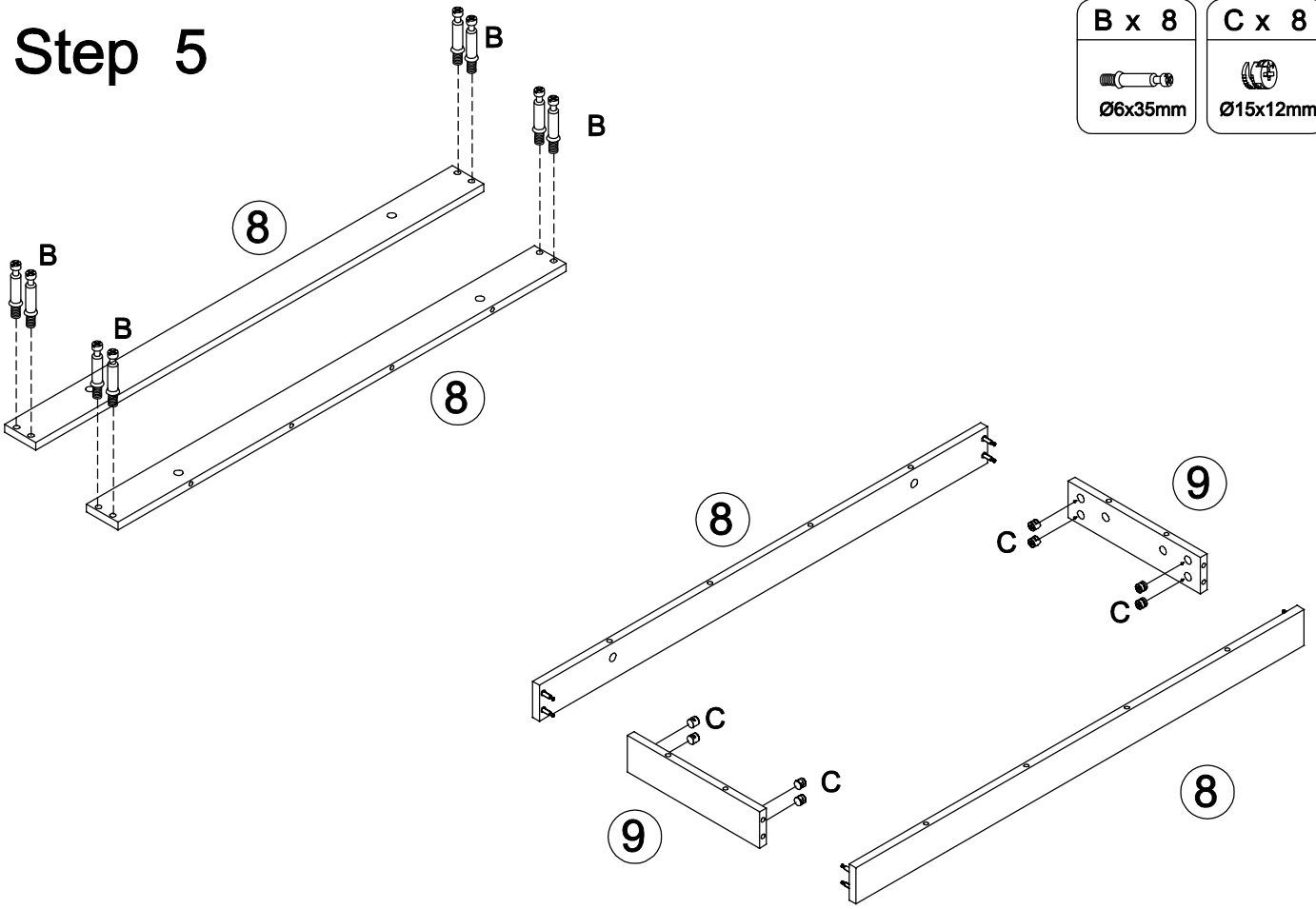
B x 8	C x 8
 Ø6x35mm	 Ø15x12mm



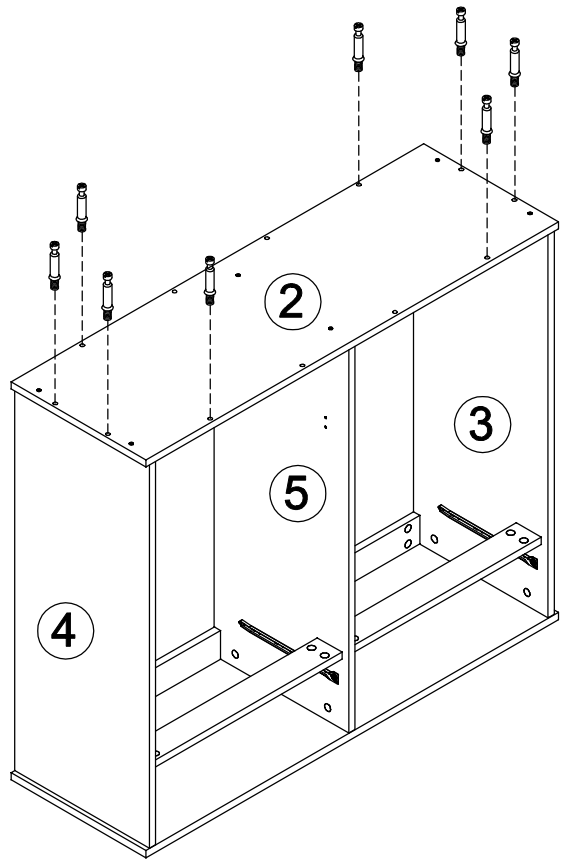

Step 6

B x 8
 Ø6x35mm



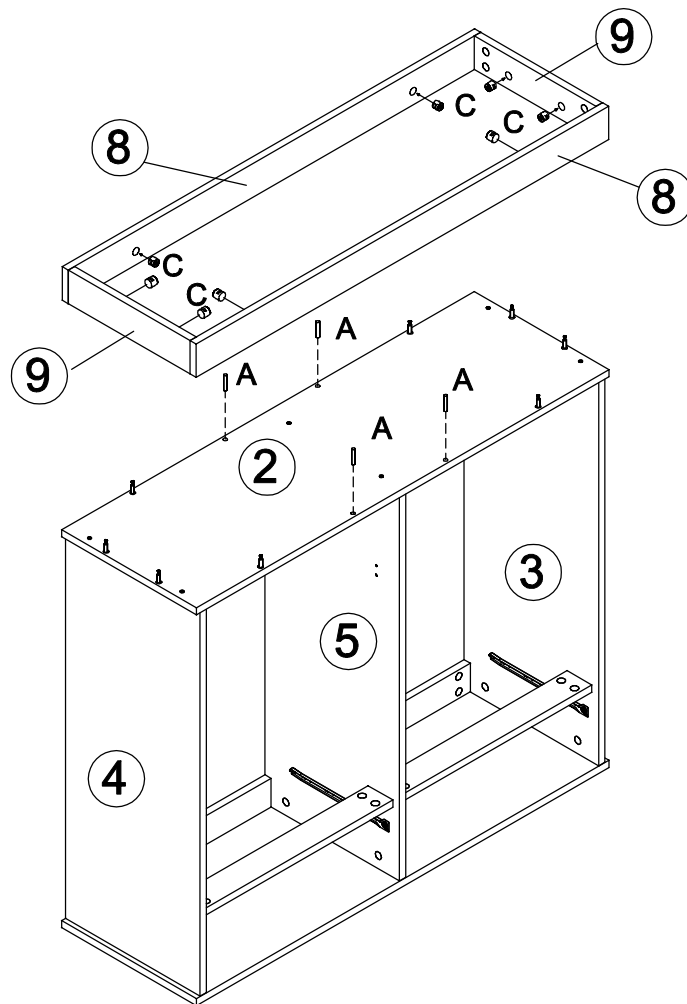

Step 7





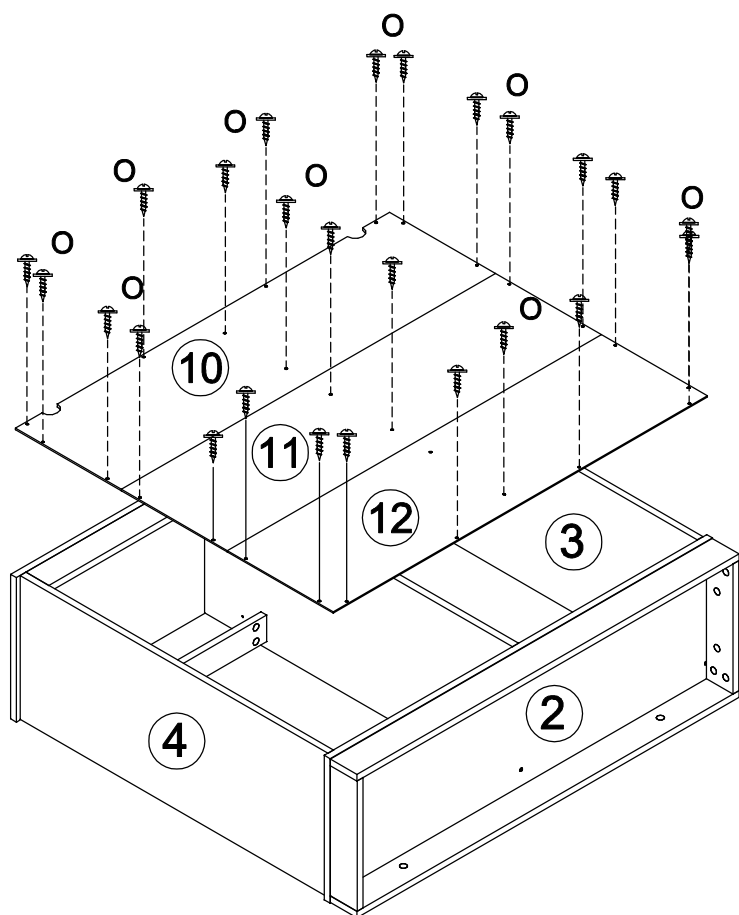
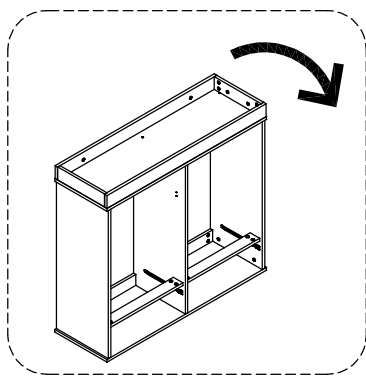

A x 4	C x 8
	
Ø8x30mm	Ø15x12mm

Step 8





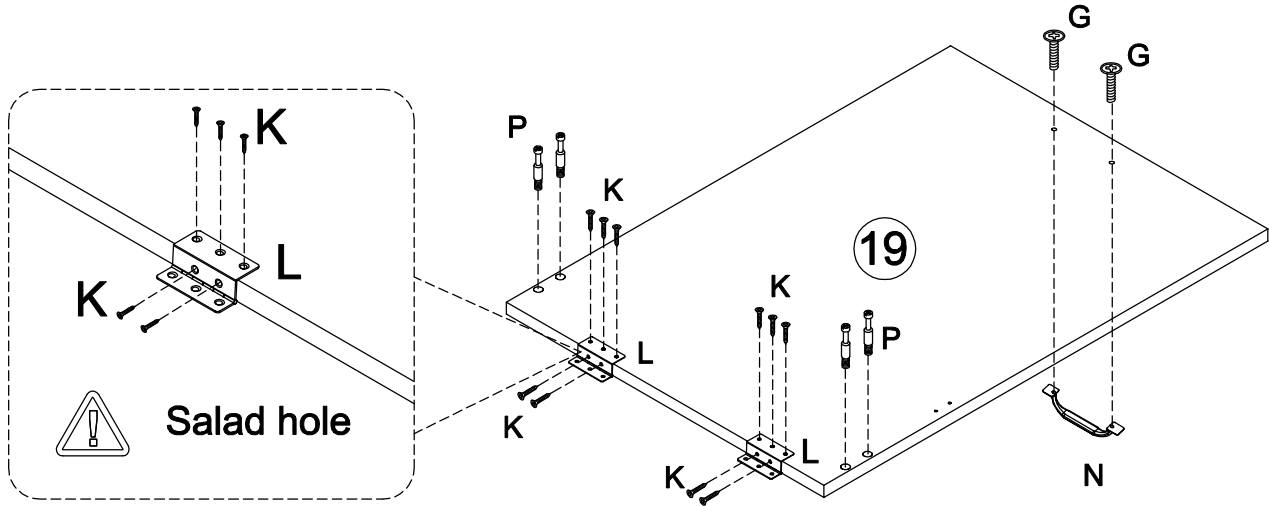

O x 26

Ø3.5x12mm

Step 9

P x 4  Ø6x32mm	G x 2  M4X20mm	K x 10  M3.5X12mm	L x 2 
			N x 1 



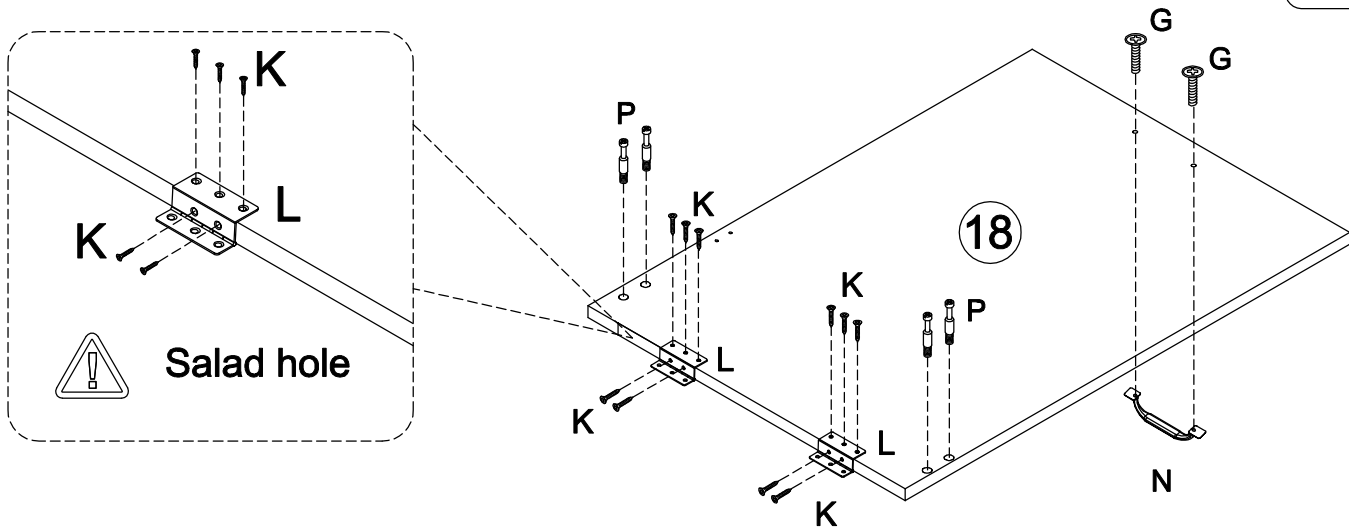

Step 10

P x 4  Ø6x32mm	G x 2  M4X20mm	K x 10  M3.5X12mm	L x 2 
			N x 1 



Step 11

K x 12	L x 4
 M3.5X12mm	

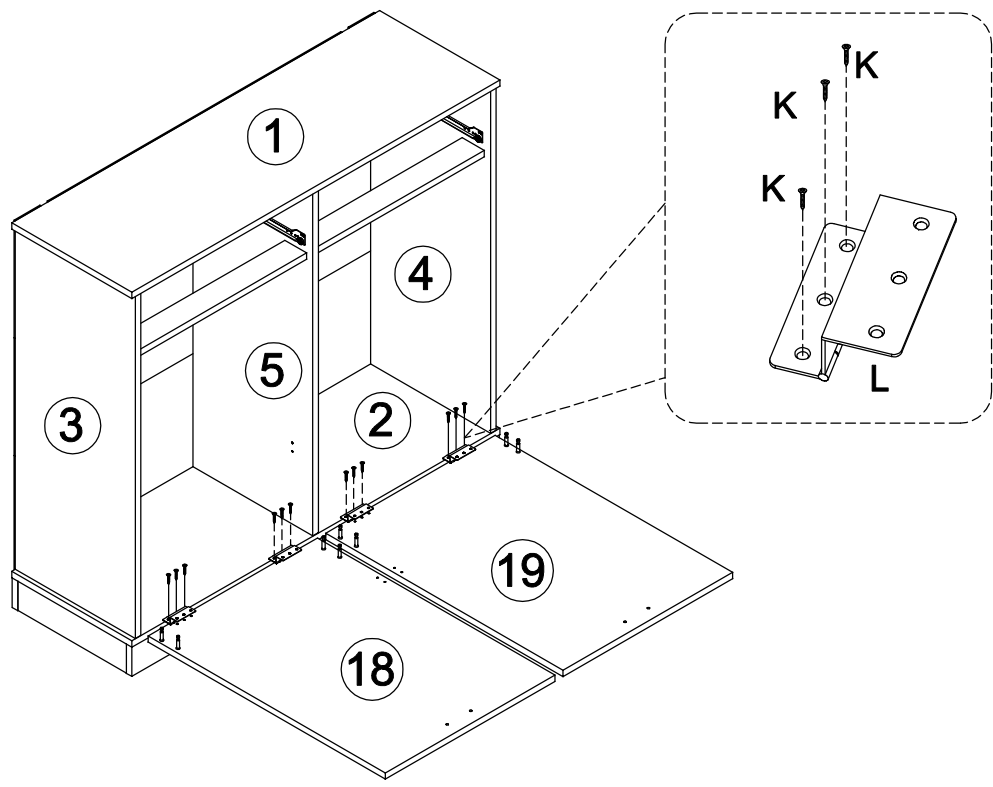

Step 12

M x 8
 M4x30mm

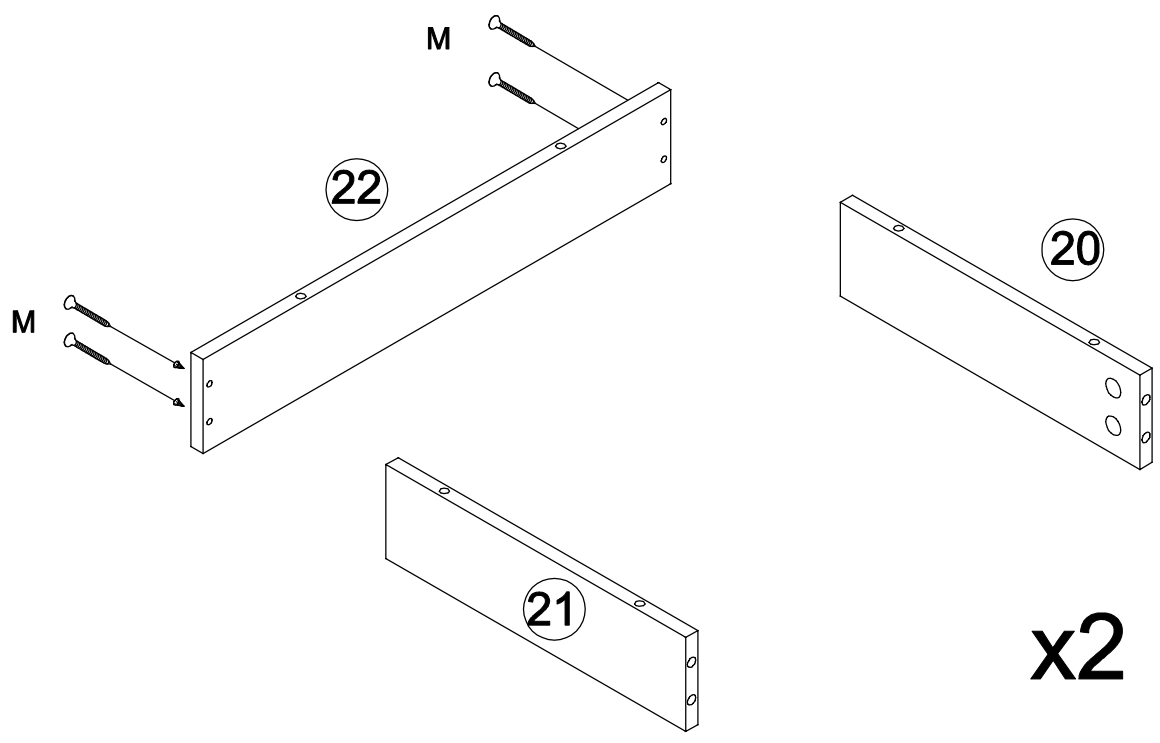

Step 13

M x 12

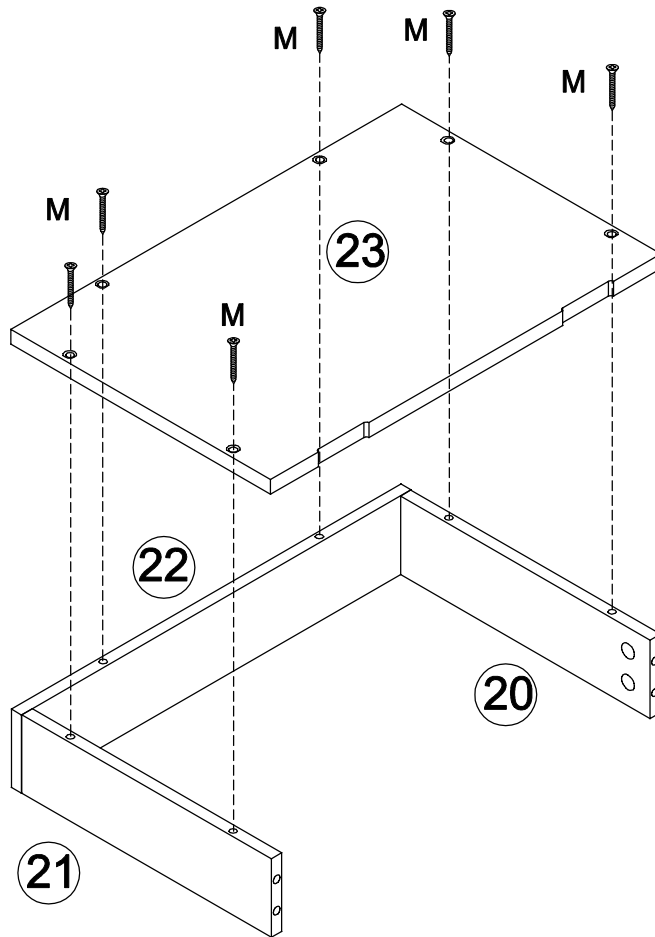



x2

Step 14

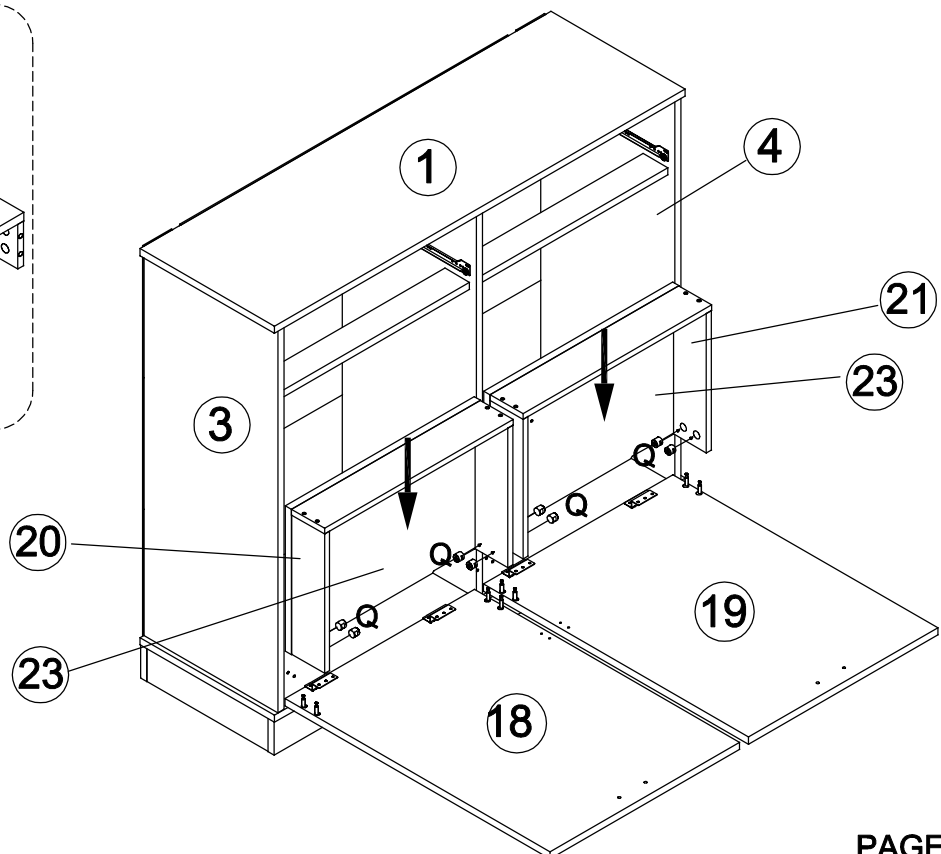
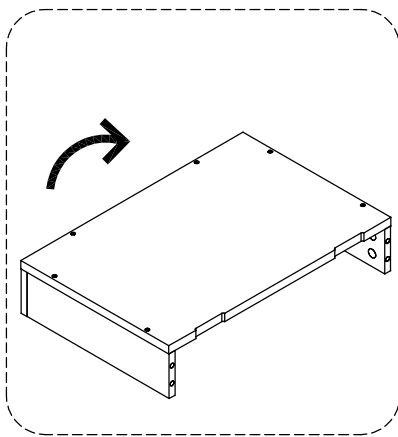
Q x 8



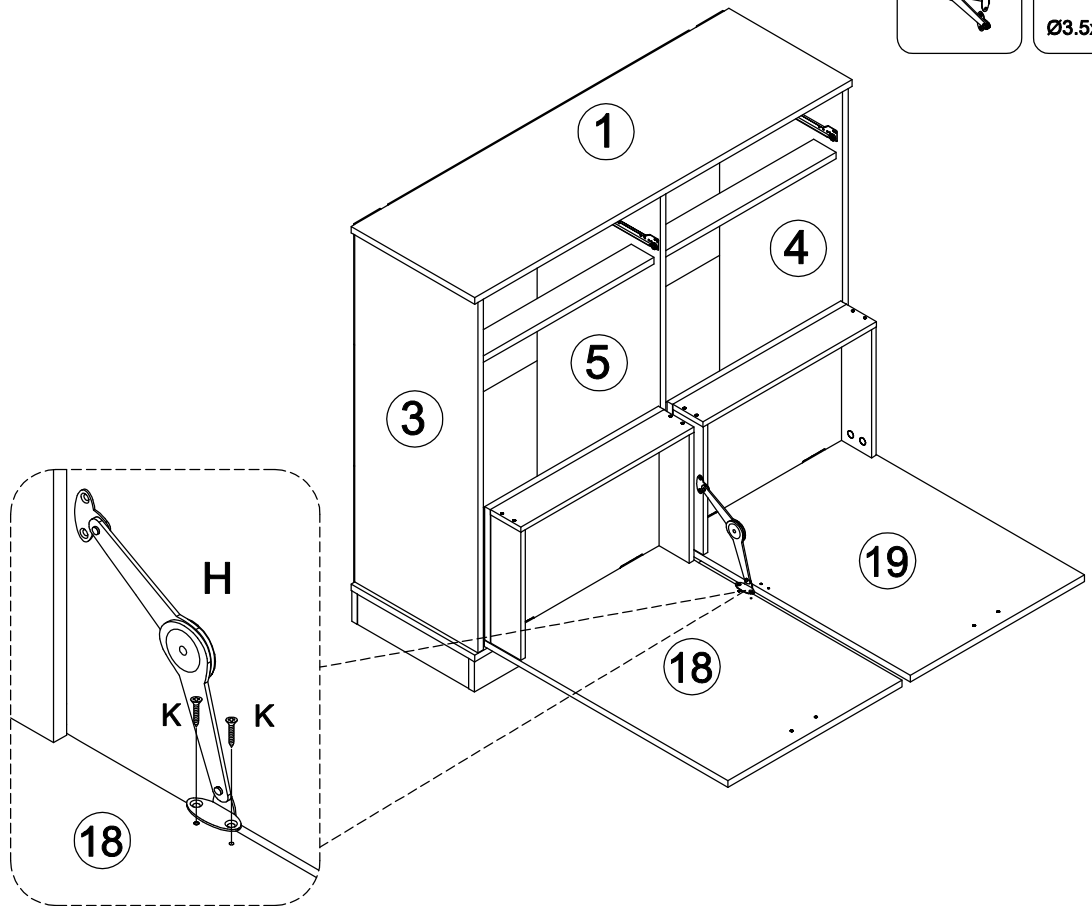

Step 15

H x 1	K x 2
	
	Ø3.5x12mm



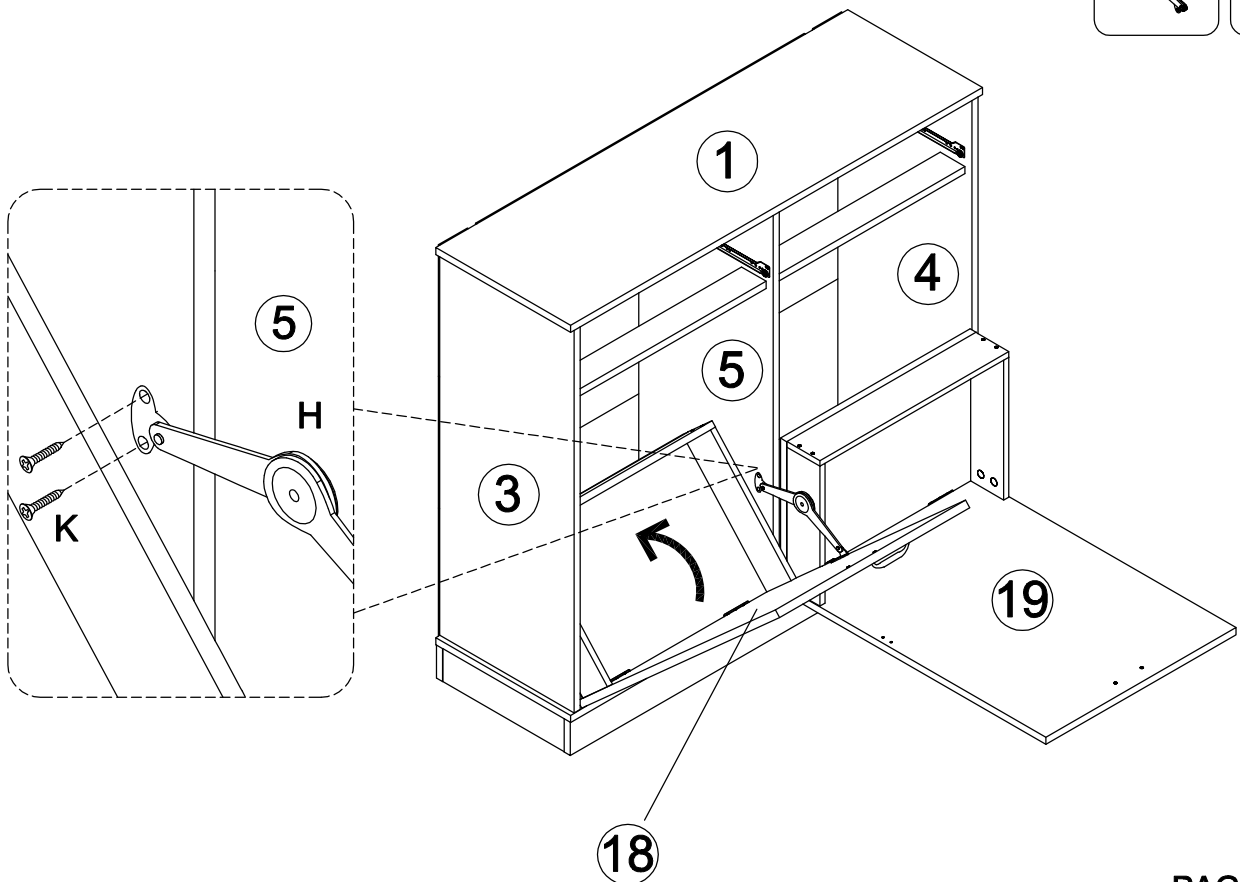

Step 16

H x 1	K x 2
	
	Ø3.5x12mm



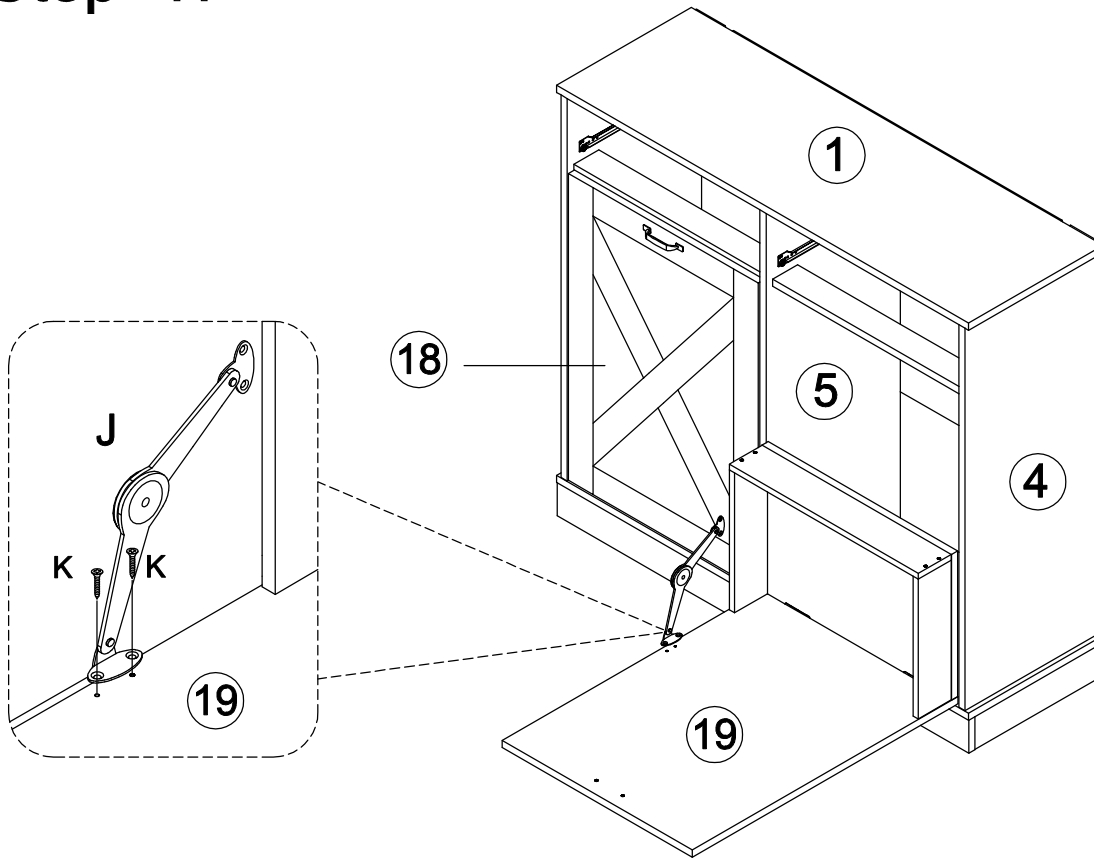

Step 17

J x 1	K x 2
	
	Ø3.5x12mm



Step 18

J x 1	K x 2
	
	Ø3.5x12mm

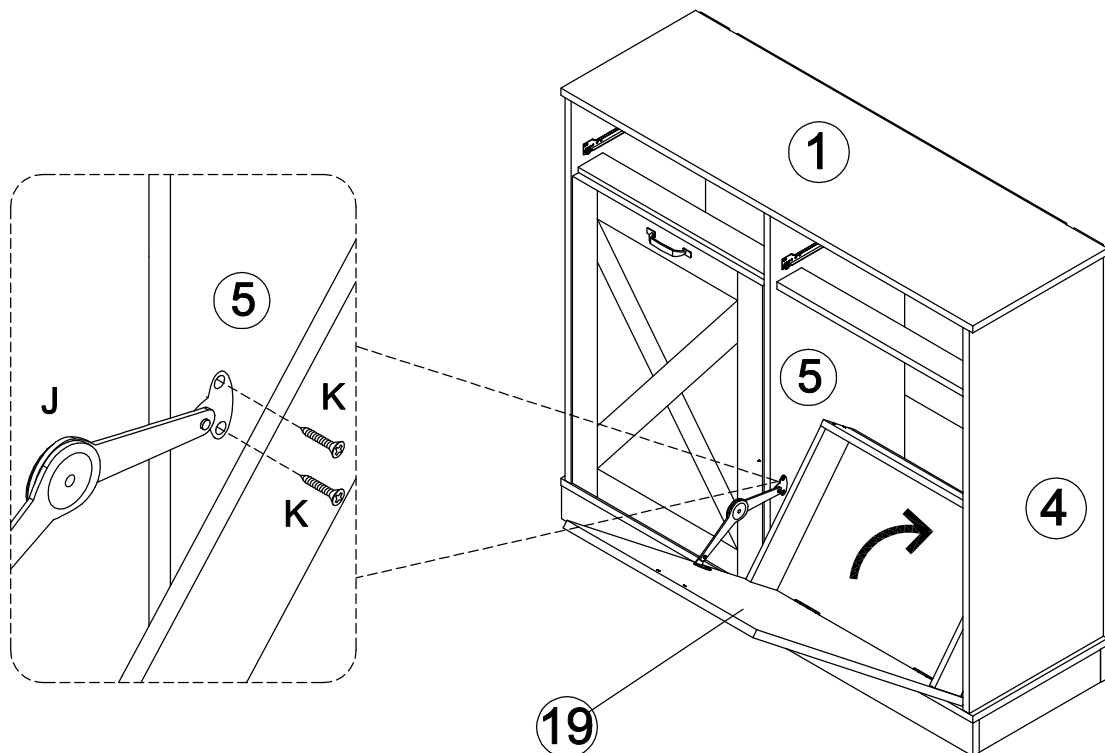

Step 19

F x 2



G x 2



M4x20mm

P x 8



Ø6x32mm

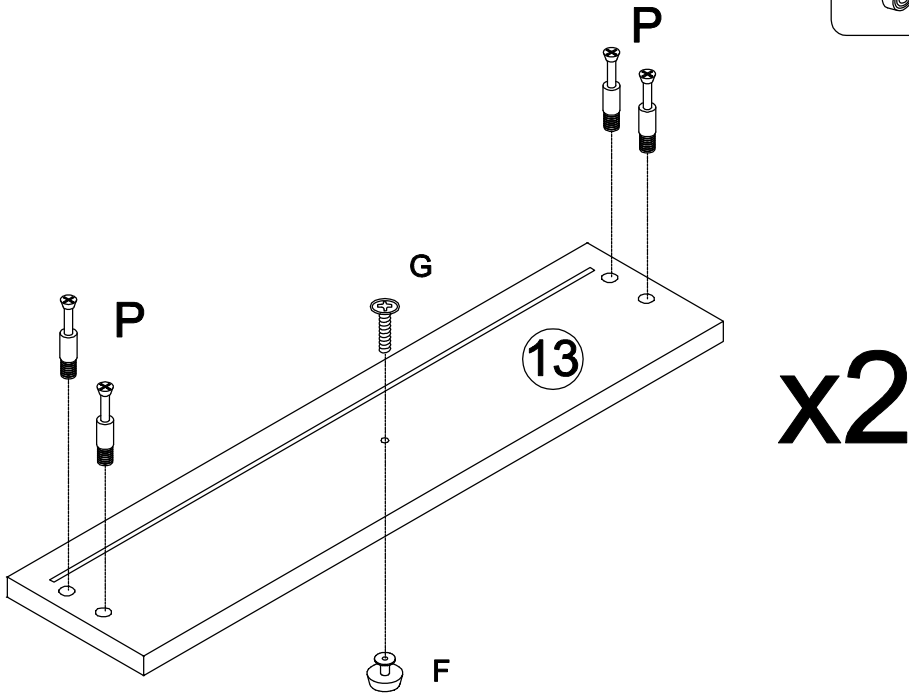

Step 20

M x 8



M4x30mm

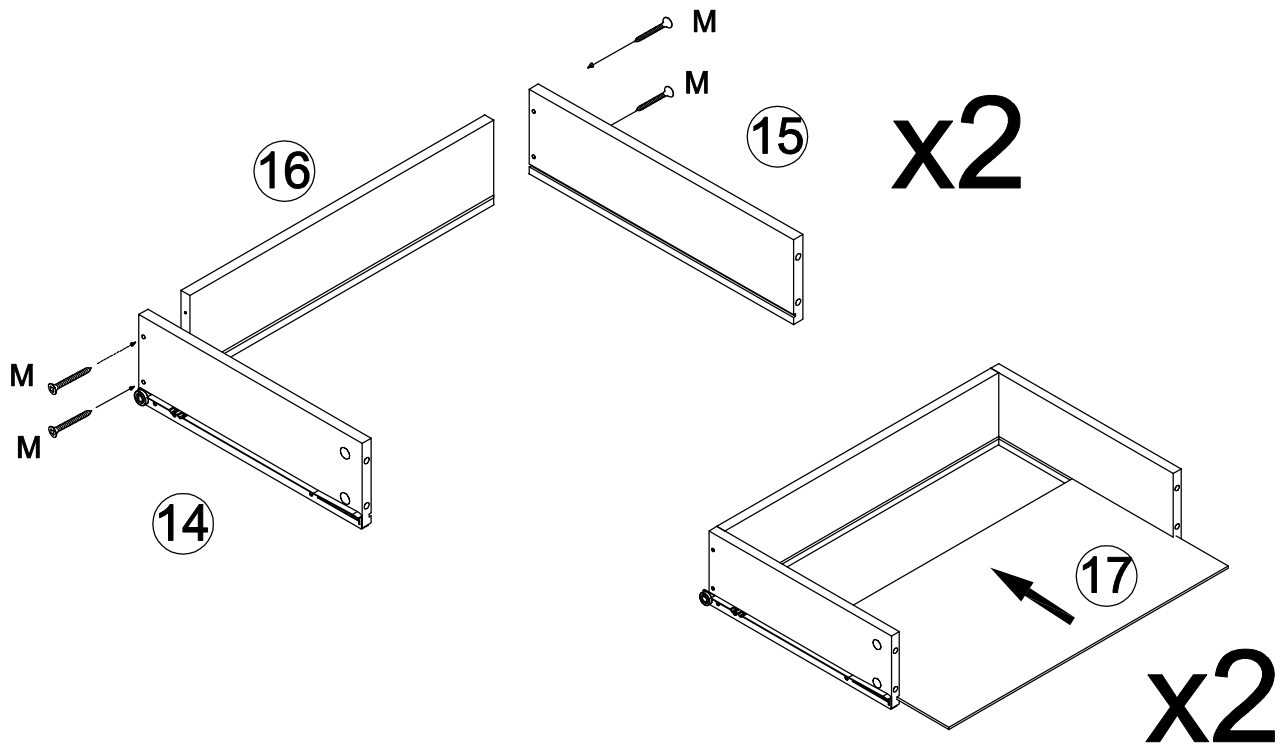

x2

Step 21

Q x 8

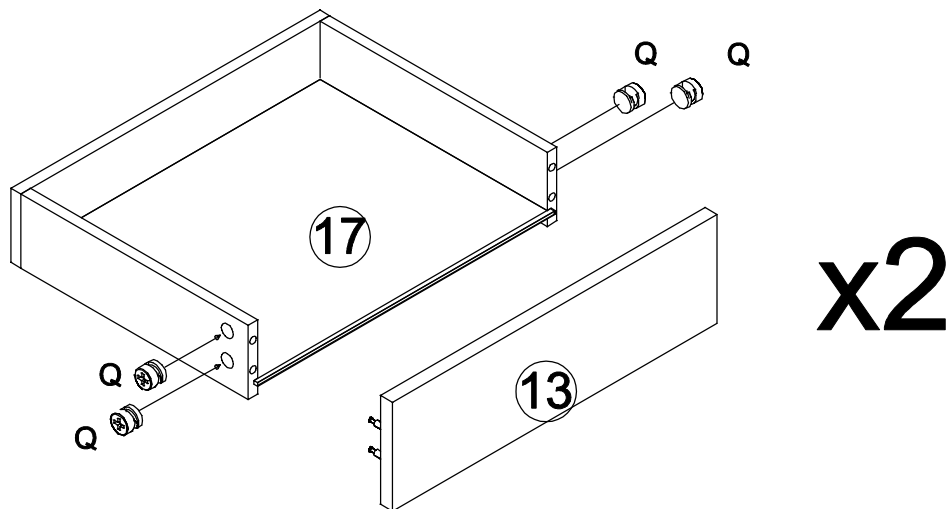

Step 22

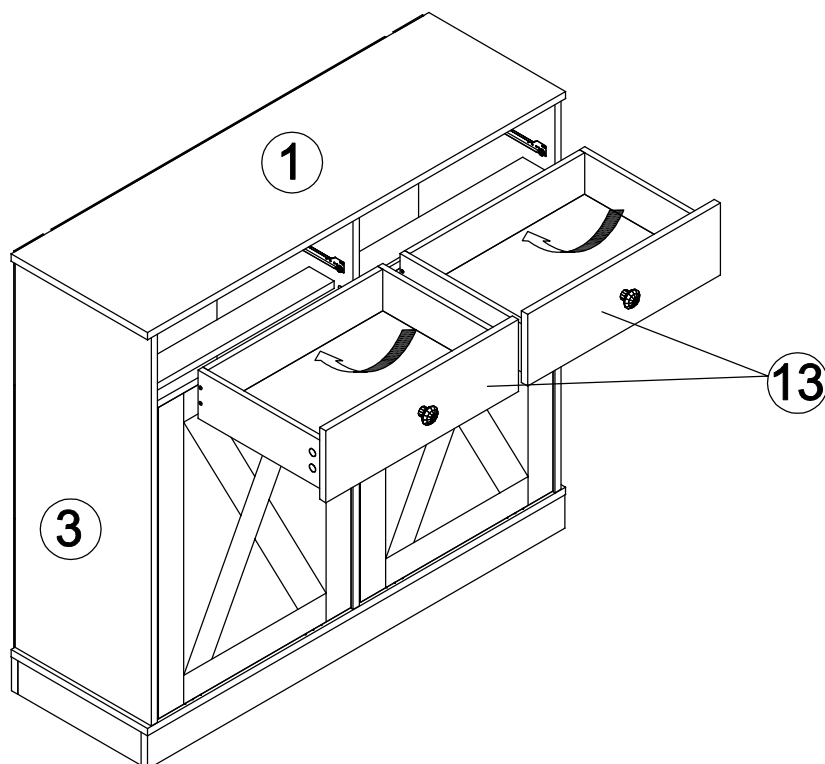

Step 23

R x 2

Back side

For Assemble
Anti Tipping
hardware

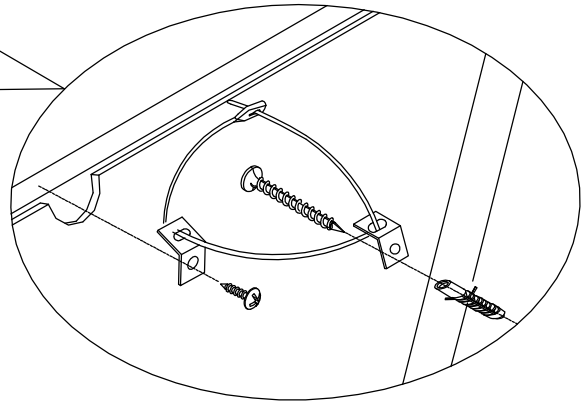
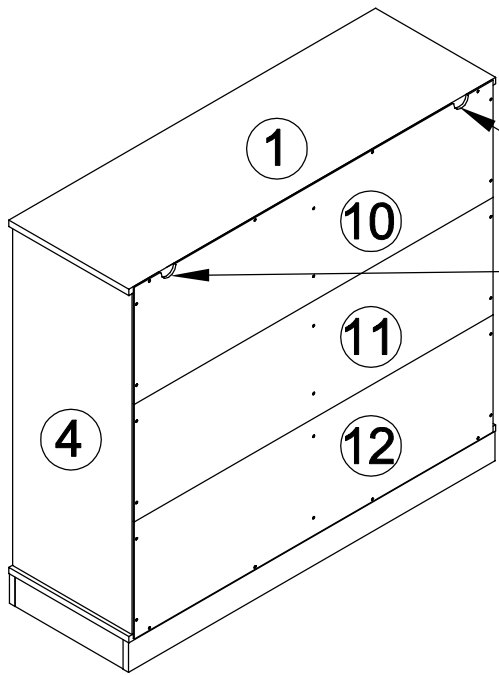

Step 24

