

Induction Cooktop

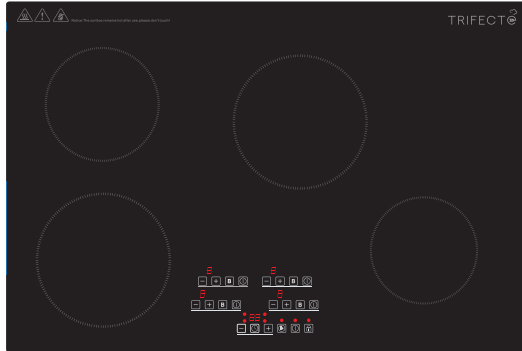
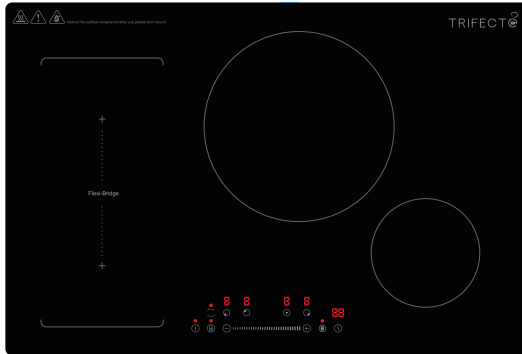

User Manual

IMPORTANT SAFETY INSTRUCTIONS
Carefully read the important information
regarding installation, safety and maintenance.
Keep these instructions for future reference.

Table of Contents

IMPORTANT SAFEGUARDS	3
INTRODUCTION TO INDUCTION COOKING	9
CARE AND CLEANING	12
IMPORTANT INSTALLATION INSTRUCTIONS	13
COUNTER INSTALLATION INSTRUCTIONS	15
SPECIFICATIONS	16
MODEL:SK-82IHA30S1	
CONTROL PANEL OVERVIEW.....	17
USING THE COOKTOP.....	18
MODEL:SK-69IHA30T2	
CONTROL PANEL OVERVIEW.....	22
USING THE COOKTOP.....	24
OTHER FUNCTIONS.....	27
TROUBLESHOOTING ERROR CODES	28
WARRANTY.....	32

Please read the entire instruction manual prior to using your unit.

IMPORTANT SAFEGUARDS

READ ALL INSTRUCTIONS BEFORE USE

Read and follow all instructions before using the cooktop to prevent the risk of fire, electric shock, personal injury, or damage when using the cooktop or appliances with the cooktop. This guide does not cover all possible conditions that may occur. Always contact your service technician or manufacturer about problems that you do not understand.



WARNING: For your safety, the information in this manual must be followed to minimize the risk of fire, electric shock or to prevent property damage, personal injury or death.

IMPORTANT NOTICE: RADIO INTERFERENCE

This unit has been tested and found to comply with the limits for a class B digital device, pursuant to Part 18 of the FCC rules. These limits are designed to provide reasonable protection against harmful interference in a residential installation.

This unit generates, uses and can radiate radio frequency energy and, if not installed and used in accordance with the instructions, may cause harmful interference to radio communications.

However, there is no guarantee that interference will not occur in a particular installation. If this unit does cause harmful interference to radio or television reception, which can be determined by turning the unit off and on.

The user is encouraged to try to correct the interference by one or more of the following measures:

- Reorient or relocate the radio and/or television receiving antennae.
- Increase the distance between the cooktop unit and radio or television receiver
- Connect the cooktop unit into an outlet or a circuit different from that to which the radio or television receiver is connected.

IMPORTANT SAFEGUARDS

READ ALL INSTRUCTIONS BEFORE USE

SAFETY PRECAUTIONS

- Do not attempt to repair or replace any part of your cooktop unless it is specifically recommended in this manual. All other service should be referred to a qualified technician.
- Remove all tape and packaging wrap before using the appliance. Destroy the carton and plastic bags after unpacking the appliance. Never allow children to play with packaging material.
- The safety aspects of this appliance comply with accepted technical standards. Know how to disconnect the electrical power to the appliance at the circuit breaker or fuse box in case of an emergency. Mark the breaker or fuse for ease of identification and swift action if necessary.
- Do not repair or replace any part of the appliance. All servicing should be done only by a qualified technician to avoid the risk of personal injury and damage to the appliance. Never modify or alter the construction of an appliance such as removal of panels, wire covers or any other permanent part of the product.
- Storage on appliance: Flammable materials should not be stored near or on the cooking surface. This includes paper, plastic and cloth items, such as cookbooks, plastic ware and towels, as well as flammable liquids. Do not store explosives, such as aerosol cans, on or near the appliance. Flammable materials may explode and result in fire, injury or property damage.
- Do not leave children alone. Children should not be left alone or unattended in the area where an appliance is in use. They should never be allowed to sit or stand on any part of the appliance.
- Do not store or use gasoline or other flammable vapors and liquids in the vicinity of this or any other appliance.



CAUTION Items of interest to children should not be stored in cabinets above a cooktop or on the backsplash of a cooktop—children climbing on the cooktop to reach items could be seriously injured



WARNING Never use your appliance for warming or heating a room.



WARNING Persons with a pacemaker or similar medical device should exercise caution using or standing near an induction unit while it is in operation, as the electromagnetic field may affect the working of the pacemaker or similar medical device. It would be advisable to consult your doctor or the pacemaker or similar medical device manufacturer about your particular situation.



CAUTION DO NOT touch Cooking Zones or areas near these surfaces. Cooking Zones may be hot from residual heat even though they are dark in color. Areas near the Cooking Zones may become hot enough to cause burns. During and after use, do not touch or let clothing or other flammable materials touch these areas until they have had sufficient time to cool.

IMPORTANT SAFEGUARDS

READ ALL INSTRUCTIONS BEFORE USE

SAFETY PRECAUTIONS

- **Wear proper apparel. Loose-fitting or hanging garments should never be worn while using the appliance.** Do not let clothing or other flammable materials contact hot surfaces.
- **Do not use water or flour on grease fires.** Smother the fire with a pan lid, or use baking soda, a dry chemical or foam-type extinguisher.
- **When heating fat or grease, watch it closely.** Fat or grease may catch fire if allowed to become too hot.
- Use only dry pot holders. Moist or damp pot holders on hot surfaces may result in burns from steam. Do not let the pot holders touch hot surface units. Do not use a towel or other bulky cloth instead of a pot holder.
- Do not heat unopened food containers. Buildup of pressure may cause the container to burst and result in injury.

ELECTRICAL SAFETY



WARNING

- If the surface is cracked, switch off the appliance to avoid the possibility of electric shock. Do not reuse your COOKTOP until the glass surface has been changed.
- When using the COOKTOP, never use aluminum foil, products wrapped in aluminum foil, or deep-frozen food in aluminum cookware.
- If the supply cord is damaged, it must be replaced by the manufacturer, its service agent or similarly qualified persons in order to avoid a hazard.

- The installation and connection of the new appliance must only be carried out by qualified personnel.
- Flush-mounted appliances may only be operated following installation in suitable cabinets and workplaces which conform to the relevant standards. This ensures sufficient protection against electric shock as required by certification agencies.
- If your appliance malfunctions or breaks, switch off all cooking zones and contact Service Center.
- Proper Installation – Be sure your appliance is properly installed and grounded by a qualified technician.

CHILD SAFETY



WARNING

- This appliance is not intended for use by young children or infirm persons unless they have been adequately supervised by a responsible person to ensure that they can use the appliance safely.
- Young children should be supervised to ensure that they do not play with the appliance.
- Accessible parts may become hot during use. Young children should be kept away.

IMPORTANT SAFEGUARDS

READ ALL INSTRUCTIONS BEFORE USE

SAFETY DURING USE

- This appliance may only be used for normal cooking and frying in the home. It is not designed for commercial or industrial purposes.
- Do not use the cooktop to heat the room.
- Take care when plugging in electric appliances near the cooktop. Cords must not come into contact with the hot surface. This could cause damage to the cooktop and cable insulation.
- Overheated fats and oils catch fire quickly. You should supervise cooking when preparing foods in fat or oil.
- After use, switch off the cooktop element by its control and do not rely on the pan detector.
- Always keep the control panels clean and dry. Do not let liquids or grease remain on the cooktop controls area. Spilled or burnt-on foods can activate or deactivate the appliance. Clean the controls area thoroughly to resume normal operation of the appliance.
- Never place combustible items on the cooktop.
- Never keep any combustible items or aerosol cans in a drawer located under the cooktop.
- Avoid placing metal cooking utensils on the cooking surface areas. Metal objects can become hot and cause burns.
- Know which touch keypad controls each surface of the cooking zones.
- Clean the appliance regularly to keep all parts free of grease that could catch fire. Exhaust fan ventilation hoods and grease filters should be kept clean. Do not allow grease to accumulate on hood or filter. Greasy deposits in the fan could catch fire. Refer to hood manufacturer's instructions for cleaning.
- Use proper pan size. This appliance is equipped with one or more Cooking Zones of different sizes.
- Select utensils having flat bottoms large enough to cover the Cooking Zones. The pan detection sensors will not allow the affected cooking zones to operate without a pan present.
- **Do not place any object on or near the control keypad area in order to prevent accidental activation of the cooktop controls.**
- Utensil handles should be turned inward and should not extend over adjacent cooking zones to reduce the risk of burns, ignition of flammable materials, and spillage due to unintentional contact with the utensil.
- Never leave prepared food on the Cooking Zones. Boil-overs cause smoke and greasy spillovers that may ignite or a pan that has boiled dry may melt or become damaged.
- Protective liners: Do not use aluminum foil to line any part of the cooktop. Only use aluminum foil as recommended after the cooking process, if used as a cover to be placed over the food. Any other use of aluminum foil may result in the risk of electric shock, fire or short circuit.
- **Glazed cooking utensils: Only certain types of glass, glass/ceramic, ceramic, earthenware, or other glazed utensils are suitable for range top service without breaking due to the sudden change in temperature.** Check the manufacturer's recommendations for cooktop use.
- **Ventilating hood: The ventilating hood above your cooking surface should be cleaned frequently so the grease from cooking vapors does not accumulate on the hood or filter.**

IMPORTANT SAFEGUARDS

READ ALL INSTRUCTIONS BEFORE USE

SAFETY DURING USE

- Do not clean or operate a broken cooktop. If cooktop should break, cleaning solutions and spillovers may penetrate the broken cooktop and create a risk of electric shock. Contact a qualified technician immediately.
- Clean cooktop with caution. If a wet sponge or cloth is used to wipe spills on a hot cooking area, be careful to avoid a steam cloud. Some cleaners can produce harmful fumes if applied to a hot surface.
- Do not place hot cookware on cold cooktop glass. This could cause glass to break.
- Do not slide pans across the cooktop surface. They may scratch the cooktop surface.
- Do not let pans boil dry. This may cause permanent damage in the form of breakage, fusion or marking that can affect the ceramic-glass cooktop (this type of damage is not covered by your warranty).
- Never leave surface units unattended at high heat settings. Boil-overs cause smoke and greasy spillovers that may ignite.



CAUTION

DO NOT pick up the bridge pan handles after cooking. They might be hot and there is a risk of burning yourself.

SAFETY WHEN CLEANING

- Always switch off the appliance before cleaning.
- For safety reasons, do not clean the appliance with a steam jet or high-pressure cleaner.
- Clean the cooktop in accordance with the maintenance and cleaning instructions in this manual.
- Steam cleaner is not to be used for cleaning of the cooktop.
- Do not use harsh abrasive cleaners or rough metal scrapers to clean the cooktop glass since they can scratch the surface, which may result in shattering of the glass.

COOK MEAT AND POULTRY THOROUGHLY

Cook meat and poultry thoroughly—meat to at least an INTERNAL temperature of 160°F and poultry to at least an INTERNAL temperature of 180°F. Cooking to these temperatures usually protect against foodborne illness.

IMPORTANT SAFEGUARDS

READ ALL INSTRUCTIONS BEFORE USE

HOW TO AVOID DAMAGE TO THE APPLIANCE

- Prior to using your cooktop for the first time, apply the recommended cooktop cleaning cream to the ceramic surface. Buff with a non-abrasive cloth or pad. This will make cleaning easier when soiled from cooking. The special cooktop cleaning cream leaves a protective finish on the glass to help prevent scratches and abrasions.
- Do not use the cooktop as a work surface or storage space.
- Please be careful on the edges when moving pots and pans around.
- Do not have the cooking zones on with empty pans or with no pots or pans on them.
- Ceramic glass is very tough and impervious to sharp temperature changes but is not unbreakable. It can be damaged if particularly hard or sharp objects fall onto it.
- Be very cautious when using pots made of cast iron or other pots with rough edges or burrs. Moving these can cause scratches on glass.
- If sugar or a mixture containing sugar falls onto a hot cooking zone and melts, remove immediately, while still hot. If left to cool down, it may damage the surface when removed.
NOTE: There is a risk of burning yourself when the glass scraper is used on a hot cooking zone!
- Keep meltable objects or materials away from the ceramic glass surface, for example, plastic utensils, aluminum foil or cooking wraps. If any materials or foods melt on the ceramic-glass surface, these should be cleaned up immediately.

DISPOSAL OF OLD APPLIANCES

To protect the environment, it is important that worn-out appliances are disposed of in the correct manner.

- The appliance must not be disposed of with household rubbish.
- You can obtain information about collection or public refuse disposal sites from your local health council or environmental health office.



CAUTION Before disposing of old appliances, please make them inoperable so they cannot be a source of danger. To do this, have a qualified person disconnect the appliance from the house circuitry.

READ AND FOLLOW THIS SAFETY INFORMATION CAREFULLY

SAVE THESE INSTRUCTIONS

Introduction to Induction Cooking

INDUCTION COOKING

How Induction Cooking Works

An induction coil is beneath the ceramic glass cooking surface. This generates magnetic fields, which act directly on the base of the pots and pans as compared to methods that first heat the ceramic glass. This means that the base of the pan is immediately heated up, saving time and energy.

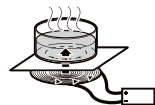

Since the heat required for cooking is generated directly in the base of the pan, the Cooking Zone itself warms up only slightly. The cooktop becomes hot from the heat from the base of the pan.

NOTE: If there is no pot or pan on the cooking zone, there is no energy transfer (heating up). This prevents the Cooking Zones being switched on and becoming hot accidentally.

IMPORTANT

- Remove all tape and packaging wrap before using the appliance. Destroy the carton and plastic bags after unpacking the appliance. Never allow children to play with packaging materials.
- Electromagnetic fields can affect electronic circuits and interfere with portable radios and phones.
- Do not put magnetically active objects (e.g. credit cards, computer diskettes, cassettes) on or near the ceramic glass surface while one or more induction cooking zones are in use!
- Do not put any metallic objects (e.g., spoons, pan lids) on the Cooking Zones as they can become hot when the Cooking Zones are in use.

Selecting Cookware

The magnetic Cooking Zone sensors located below the cooktop surface require the use of cookware made with magnetic material in order to start the heating process on any of the Cooking Zones. When purchasing pans, look for cookware specifically labeled by the manufacturer for use with induction cooktops.

Pots and Pans

- In principle, all pots and pans with magnetic bases are suitable. These include steel, steel-enamel as well as cast-iron pots and pans.
- High grade steel pans with a mixed metal base are suitable for induction only if the manufacturer has expressly marked them as such. In that case, they have a magnetic material in the base.
- If you wish to use a special type of pan (e.g., a pressure cooker, simmering pan, wok), please follow the manufacturer's instructions and do not use a very thin pan.

NOTE: Some cookware can produce noises when used on induction cooking zones. This is not a fault in the cooktop, and its function will not be impaired in any way as a result.

Suitability Test

If you are not sure if a pot or pan is suitable for use with your induction cooktop, you can find out with a few simple tests:

- Place a pot filled with a little water (1/8" or 1/4") on the Cooking Zone. Set the Cooking Zone to full power (power level 9).

Introduction to Induction Cooking

Selecting Cookware



CAUTION The pan base of suitable kitchenware heats up within a few seconds! The water should boil rapidly.

- You can also check cookware suitability with a magnet. If the magnet remains fixed to the base of the pan, the pan is suitable for induction cooking.

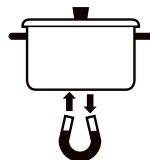

Avoiding Scratches

It is recommended to always use heavier gauge stainless steel cookware on your induction cooktop surface. This will help reduce the possibility of developing scratches on the ceramic surface. Low-quality cookware can scratch the cooktop surface.

Cookware should always be lifted over the ceramic cooktop surface to prevent scratching. Sliding any type of cookware over the ceramic cooktop can affect the overall appearance of the cooktop. Over time, sliding ANY type of cookware over the ceramic cooktop may alter the overall appearance of the cooktop. Eventually, the buildup of scratches can make cleaning the surface difficult and degrade the overall appearance of the cooktop.

Scratches can also result from grains of sand (e.g., after washing vegetables) which are dragged with the pot across the cooking surface.

Use Flat-Bottomed Cookware

Cookware must fully contact the surface of the cooking element. Use flat-bottomed pans sized to fit the cooking element and the amount of food being prepared. Check for flatness by rotating a ruler across the bottom of the cookware.

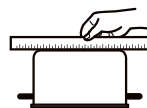

For Best Results

Always follow the recommendations for proper cookware type and size. In addition:

- Do not use dirty pans with grease buildup. Always use pans that are easy to clean after cooking and make sure that the bottoms of the pans are clean and dry.
- When cooking with large amounts of liquid, use large pots so that nothing can boil over.
- Do not let pans boil dry. This may cause permanent damage in the form of breakage, fusion or marring that can affect the ceramic cooktop (this type of damage is not covered by your warranty).
- Match the pan size and Cooking Zone to the amount of food being prepared.

Tips for Saving Energy

- Always position pots and pans before you switch on the Cooking Zone.
- Dirty cooking zones and cookware use more electricity
- Whenever possible, always have the lid firmly placed on the pots and pans so that they are completely covered.

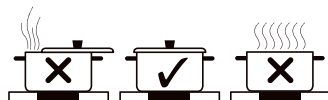

Introduction to Induction Cooking

Selecting Cookware

Cookware Selection and Placement

It is important that the proper cookware be used and placed correctly on the cooktop. ANY one of the incorrect conditions shown below may be detected by the sensors located below the ceramic cooktop surface. If this happens, one or more of the Cooking Zones will not heat, and an E will appear in the affected Cooking Zone display. Correct the problem before attempting to use the cooktop.

Correct



Cookware centered correctly on Cooking Zone surface.



Flat pan bottom & straight sides.



Pan size meets or exceeds the recommended minimum size for the Cooking Zone.



Pan rests completely on the cooktop surface.



Pan is properly balanced.

Incorrect



Cookware not centered on Cooking Zone surface.



Curved or warped pan bottoms or sides

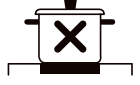

Pan does not meet the minimum size required for the Cooking Zone used.

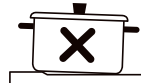

Pan bottom rests on cooktop trim or does not rest completely on the cooktop surface.



Heavy handle tilts pan.

Cooking Noise

It is normal for cooktop to generate minor noises or buzz while in use. The sounds you may hear depend on cookware material, size of pan, amount of contents, power level and heating elements used.

- Heavy pans such as enameled cast iron pans are quieter than light weight multi-ply stainless steel pans.
- Pans that cover entirely the heating element are less noisy.
- Cooktop may produce noises if the pan contents are cold. As pan warms up, the sound will diminish.
- Hearing a low humming noise or buzz is normal when cooking on high settings. When reducing power levels, the noise level will decrease as well.
- When using simultaneous heating elements at certain power levels, the magnetic fields may interact and produce a soft whistle or intermitted “hum”. By lowering or raising the power level settings of one or both of the elements, these noises can be reduced or eliminated.

Care and Cleaning

Cleaning the Cooktop

General cleaning for induction ceramic glass cooking surfaces is considerably easier than for cooking surfaces with radiant heating.

NOTE: To prevent accidental activation of the controls, it is recommended that you set the CHILD LOCK feature before cleaning.

IMPORTANT

- Cleaning agents must not come into contact with the hot ceramic glass surface. All cleaning agents must be rinsed off thoroughly with clean water.
- Do not use any aggressive cleaners such as grill or oven sprays, coarse scouring cleansers or abrasive pan cleaners.
- Clean the ceramic-glass surface after each use when it is warm to the touch or cold. This will prevent spills from becoming burnt on. Remove water marks, grease and discoloration with a glass scraper and ceramic glass cleaner.

NOTE: You may purchase glass scrapers and ceramic glass cleaners from your local hardware store.

General Cleaning

1. When it is cool, wipe the ceramic glass surface with a damp cloth and a small amount of ceramic glass cleaner.
2. Wipe dry with a clean cloth.
3. Once a week, thoroughly clean the entire ceramic-glass cooking surface with a commercially available ceramic glass cleaner.
4. Then, wipe the ceramic glass surface using a clean, soft cloth dampened with clean water and polish dry with a clean lint-free cloth.

Removing Heavy Soil

To remove food that has boiled over or stubborn spills, use a glass scraper.

1. Hold the glass scraper at an angle of about 45° to the ceramic-glass surface.
2. Remove soiling by sliding the blade across the area.
3. Use a ceramic glass cleaner as described in GENERAL CLEANING.

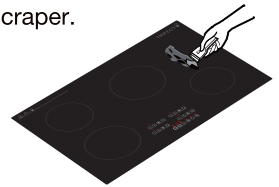

Problem Soils

1. Remove sugar, melted plastic, aluminum foil, or other meltable materials with a glass scraper immediately and while still hot. Failure to do so can cause permanent damage to the cooktop surface. If the Cooking Zone has already cooled down, warm it up again.

IMPORTANT: There is a risk of burning yourself when the glass scraper is used on a hot Cooking Zone. Use care and wear an oven mitt.

2. Then clean the cooktop normally when it has cooled down.

NOTE: Scratches or dark marks on the ceramic glass surface caused by a pan base with sharp edges cannot be removed. However, they do not impair the function of the cooktop.

Important Installation Instructions

Cooktop ventilation

- It is very important to provide adequate ventilation for optimal operation. Installing over vented cabinets is highly recommended.

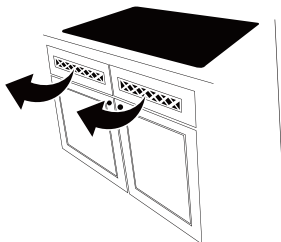

WARNING Allow enough space between cooktop and cabinet for proper airflow. If airflow is blocked, burners can overheat and stop working temporarily.

Cooktop ventilation areas - DO NOT OBSTRUCT!

Keep ventilation areas clear, to allow proper airflow.

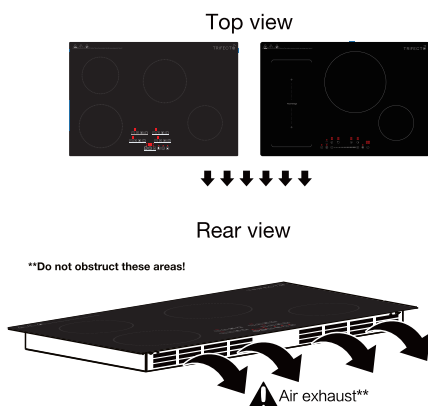

Recommended space between cooktop base if installing above oven

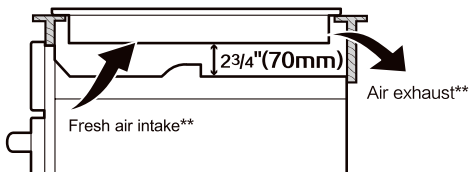

CAUTION

It is very important to keep 2 3/4" (70 mm) distance between the cooktop and the oven.



CAUTION: During cooking, built-in fan inside the cooktop will operate constantly to keep the internal components cool. The air intake is on the bottom of the cooktop box, and the warm air exhaust is located on the back and side of rim, as shown on the schematic. If the air intake or the exhaust is obstructed, the cooktop safeties will either diminish the power output or shut down the unit.

Important Installation Instructions

Preparing the Installation Location

Important – Save for the local electrical inspector's use.

- All electric cooktops run off a three phase, two live wire cable, 240 Volt, 60 Hertz, AC-only electrical supply with ground.
- Maximum distance between cooktop and overhead cabinetry is 30 inches (76.2 cm)



WARNING DO NOT apply any sealant along the perimeter. The cooktop must breath freely.

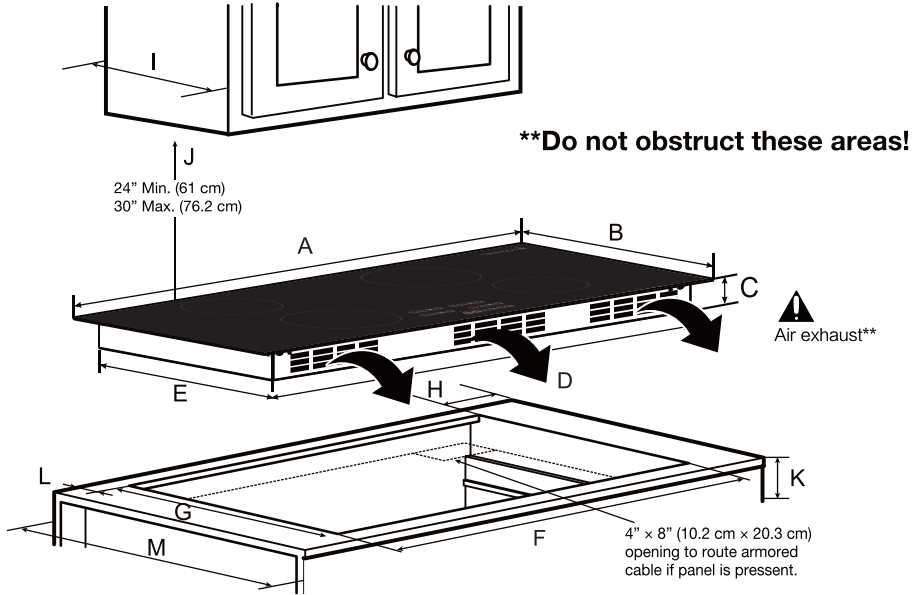

Unit	A	B	C	D	E	F	G	H	I	J		K	L	M
										Min	Max			
Inch	30	20 ¹ / ₂	2 ¹⁵ / ₁₆	28 ³ / ₄	19 ⁹ / ₃₂	29 ⁹ / ₃₂	20 ¹ / ₁₆	13 ¹ / ₁₆	12	24	30	4 ¹⁵ / ₁₆	1 ¹ / ₂	24
mm	770	520	75	730	490	744	510	20	305	610	762	125	38	610

All dimensions are stated in inches and millimeters (mm).

Allow 2" (5 cm) space below the armored cable opening to clear the electric cable and allow space for installation of the junction box on the wall at the back of the cooktop.

Counter Installation Instructions

Before installing the cooktop

1. Visually inspect the cooktop for damage. Also make sure all cooktop screws are on tight.
2. Place the cooktop into the countertop cut-out.

Model and Serial Number Location

The serial plate is located at the front edge of the cooktop. When ordering parts or making inquiries about your cooktop, be sure to include the model and serial numbers.

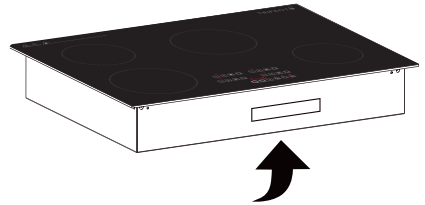

Serial plate is located at the front edge of the burner box of the cooktop.

Connecting to a 3 wires power supply cable electrical system

1. Disconnect the power supply.
2. In the circuit breaker, fuse box, or junction box, connect appliance and power supply cable wires as shown below.
3. Circuit breaker fuse rating must be above 40 A, and wire should be 2/8 or 3/8 copper.
4. Minimum acceptable size of conductors should be no less than 10AWG, copper only, and no less than 167°F.
5. A wire-binding screw or stud used in the wire terminal should be 10 or larger.

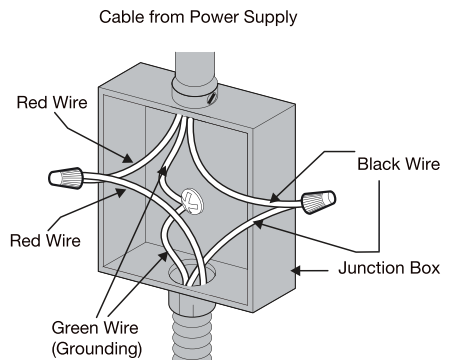

WARNING

1. The electrical power to the cooktop must be shut off while line connections are being made. Failure to do so could result in serious injury or death.
2. An extension cord must not be used with this appliance. Such use may result in a fire, electrical shock or other personal injury.

The Induction Cooktops must connect to a separate grounded wire, single phase, AC Only electrical supply with their own circuit breaker. These appliances must be installed in accordance with National Electrical Codes, as well as all state, municipal and local codes. This appliance must be supplied with the proper voltage and frequency and amperage, which is protected by a properly sized circuit breaker or time delay fuse. Installation work and electrical wiring must be done by licensed qualified person(s) in accordance with all applicable codes and standards.

Specifications

Model	SK-82IHA30S1	SK-69IHA30T2
Total power (Watts)	8200	6900
Front left	2000W/2500W	2000W/2700W
Rear left	2000W/2500W	1500W/2000W
Rear right	2700W/3700W	2000W/2700W
Front right	1500W/2000W	1400W/1800W
Flex(Bridge) Zone	3500W/3700W	/
Voltage	240V / 60Hz	
Level Selection	Select settings 1 through 9	
Max Time	Set timer from 1 to 99 minutes	
Material	Glass Ceramic Top / Metal Body	
Unit Measurements	30"W x 20½"D x 2 ¹⁵ / ₁₆ "H	
Installation Type	Drop-in	
Installs Over Built-in Oven	Yes	
Installation Dimensions (WxD)	28¾" x 19 ³ / ₂ " Min	

Temp Range	Power Level	Description
Low	1	Melt, keep foods warm
Medium Low	2-4	Continue cooking, poach, stew
Medium	5-6	Maintain a slow boil, thicken sauces and gravies, steaming, cooking
Medium High	7-8	Continue a rapid boil, fry, or deep fry
High	9	Start most foods, maintain water at a boil, pan frying, searing
Power Boost	b	Start heating pans that contain large amounts of food or to bring pots of water to boil

Note: 1-5 gears are intermittent heating.

 **Note:** The data in the table is for guidance only. The relation between the heat setting and the cooking zone consumption of power is not linear. When you increase the heat setting it is not proportional to the increase of the cooking zone consumption of power.

The power of the cooking zones can be different in some small range. It changes with the material and dimensions of the cookware.

Control Panel Overview

MODEL:SK-82IHA30S1

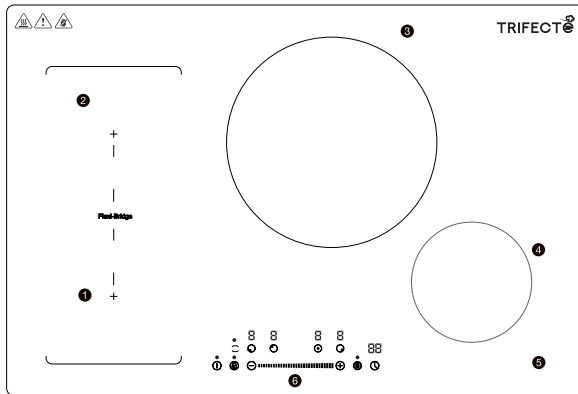

- ① Front left cooking zone
- ② Rear left cooking zone
- ③ Rear right cooking zone
- ④ Front right cooking zone
- ⑤ Ceramic glass
- ⑥ Touch control panel

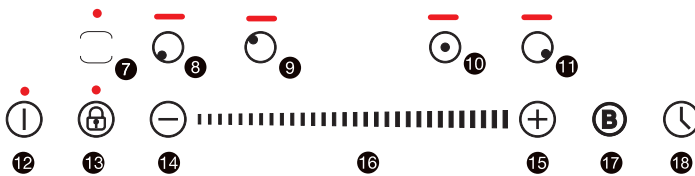

- ⑦ Flex zone key
- ⑧ Select front left cooking zone key
- ⑨ Select rear left cooking zone key
- ⑩ Select rear right cooking zone key
- ⑪ Select front right cooking zone key
- ⑫ Power ON/OFF
- ⑬ Child safety lock
- ⑭ Lower power/time key
- ⑮ Raise power/time key
- ⑯ Sliding bar
- ⑰ Boost key
- ⑱ Timer control key

Using the Cooktop

To start cooking

After power on, the buzzer beeps once, all the indicators light up for 1 second then go out, indicating that the induction cooktop has entered the state of standby mode.

- Touch the ON/OFF  control, the buzzer beeps once, indicating that the induction cooktop has entered the state of standby mode, the Power indicator light up.



The unit will automatically return to standby mode if no ON/OFF keys are touched within 30 seconds.

Note: Please do not power off the induction cooktop until the cooling fan has stopped.

- Place a suitable pan on the cooking zone that you wish to use.

Make sure the bottom of the pan and the surface are flat.

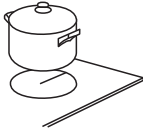

- Touching the heating zone selection control, and a indicator next to the key will flash.



- Select a heat setting by touching the "-" or "+" control or sliding the setting selector with your finger.

If you don't choose a heat setting within 30 seconds, the induction hob will automatically switch off. You will need to start again at step 1.

You can modify the heat setting at any time during cooking.

By holding down either of these buttons, the value will adjust up or down.

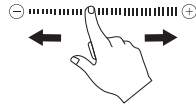

Using the Boost

Boost is the function that one zone rising to a larger power in one second and lasting for 5 minutes. Thus you can get a more powerful and faster cooking.

- Touch the heating zone selection button that you wish to boost, an indicator next to the key will flash.



- Touch the Boost button, the heating zone will begin to work at Boost mode. The power display will show "b" to indicate that the zone is boosting.

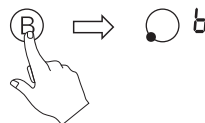

After 5 minutes, the zone will switch back to the power stage 9.

Using the Cooktop

When you have finished cooking

- Touching the heating zone selection control that you wish to switch off.



- Turn the cooking zone off by touching the "-" control until the Power digital display of the cooktop show a "-" or "H".

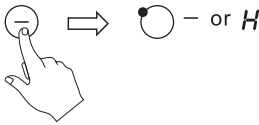

- Turn the whole cooktop off by touching the "ON/OFF" control.



Flex Zone

- This area can be used as a single zone or as two different zones, accordingly to the cooking needs anytime.
- Flexible area is made of two independent inductors that can be controlled separately. When working as a single zone, the default power level is 5.

- Important: Make sure to place the cookwares centered on the single cooking zone. In case of big pot, oval, rectangular and elongated pans, make sure to place the pans centered on the cooking zone covering both cross.

Examples for good and bad pot placements:

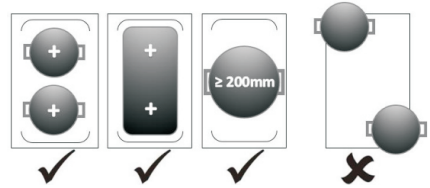

As big zone

- To activate the free area as a single big zone, simply press the Flex zone key.

The light above Flex zone key will light, which indicate Flex zone has been activated.



- Adjust heat setting by touching the slider control.

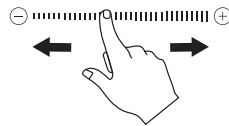

As two independent zones

Touch the Flex zone key again, the flexible area will turn to two independent heating zones.

Using the Cooktop

Controls Lock



- You can lock the controls to prevent unintended use (for example children accidentally turning the cooking zones on).
- When the controls are locked, all the controls except the Lock control and ON/OFF control are disabled.

To lock the controls

Touch and hold the keylock control  for 3 seconds. The lock indicator will light up.

To unlock the controls

- Make sure the induction hob is turned on.
- Touch and hold the keylock control  for 3 seconds.
- You can now start using your induction hob.

 When the hob is in the lock mode, all the controls are disabled except the Lock control and ON/OFF  you can always turn the induction hob off with ON/OFF  control in an emergency, but you shall unlock the hob first in the next operation.

Set Timer

With the desired heating zone Powered ON, select the desired heating zone, then press the  key. The timer display will blink and show a "30", press the "+" or "-" to increase or decrease by 1 minute to the desired time until the desired time appears in the display (Choose up to 99 minutes). Once the Timer is set, if keys haven't been pressed after 5 seconds, it will begin to countdown, the timer display will remain lit, the indicator for that particular burner will flash. When the time is completed, a "beeping" sound will go off indicating that the time is up, and selected heating zone shut off automatically.

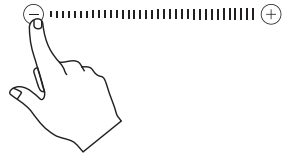

If you want to set another burner to switch-off automatically, select desired heating zone, press the  key and repeat the same steps.

If you want to check the remaining time for another zone, select desired heating zone.

If more than one switch-off time is programmed, the shortest time remaining will show in the display, the indicator for that particular burner will flash.

Canceling the Timer

Select the desired heating zone.

Press the  and the indicator will show "--", indicating that the timer of selected heating zone has been canceled.

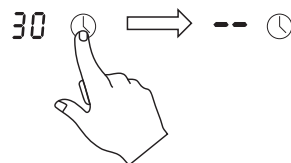

Using the Cooktop

- If more than one heating zone use this function, the timer indicator will show (e.g. zone 1# setting time of 3 minutes, zone 2# setting time of 6 minutes, the timer indicator shows "3".)

 6 (set to 6 minutes)

 3 (set to 3 minutes)

- When cooking timer expires, the corresponding Time cooking zone symbol will be switch off automatically.
- **NOTE:** If you want to change the time after the timer is set, you have to start from step 1.

Residual Heat Indicator



Your cooktop has a residual heat indicator  for each Cooking Zone. This indicator will warn that this area has been used and is still giving off enough heat to cause burns.

Avoid touching the burner when this indicator is shown. Although the cooktop is OFF, the  will stay lit until the cooktop has cooled down.

Over-Temperature Protection

A temperature sensor equipped can monitor the temperature inside the induction hob. When an excessive temperature is monitored, the induction hob will stop operation automatically.

Auto Shutdown

Another safety feature of the hob is auto shut down. This occurs whenever you forget to switch off a cooking zone. The default shutdown times are 2 hours.

Control Panel Overview

MODEL:SK-69IHA30T2

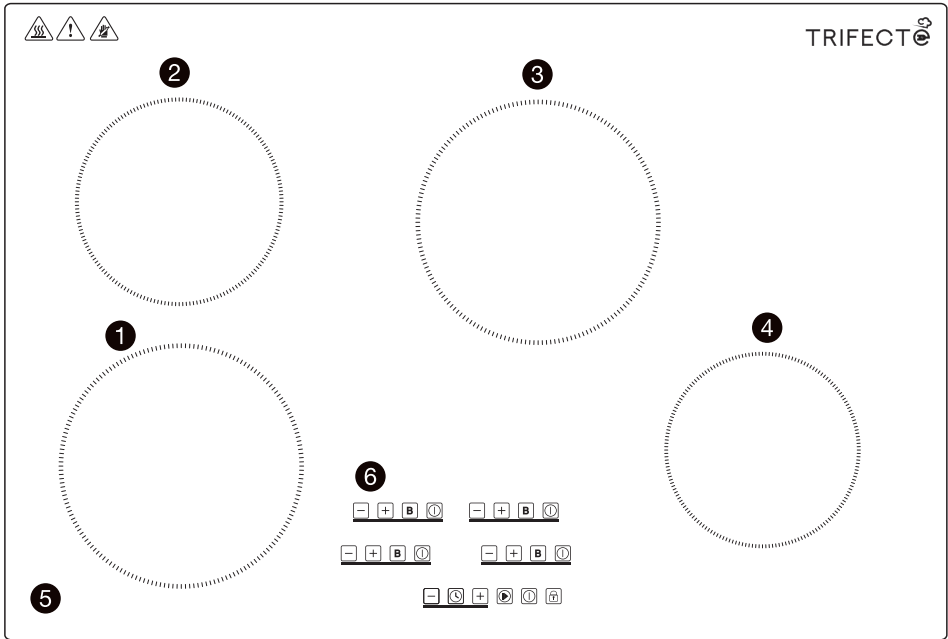

- ① Front left cooking element
- ② Rear left cooking element
- ③ Rear right cooking element
- ④ Front right cooking element
- ⑤ Ceramic glass
- ⑥ Touch control panel

Cooktop Features

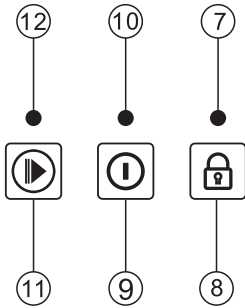

- 7 Controls Lock
- 8 Controls Lock indicator light
- 9 Main Power On/Off
- 10 Main Power indicator light
- 11 Stop/Go
- 12 Stop/Go indicator light

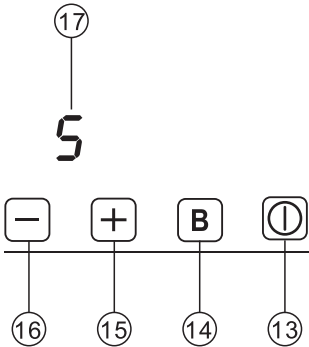

- 13 Cooking element symbol and Power On/Off
- 14 Power Boost
- 15 Increase power
- 16 Decrease power
- 17 Power level and Residual heat display

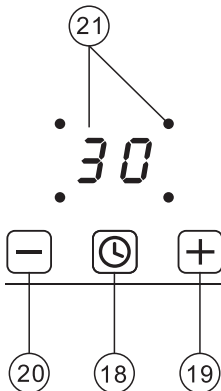

- 18 Minute timer
- 19 Minute timer setting Up
- 20 Minute timer setting Down
- 21 Minute timer display window and cooking element symbol

Using the Cooktop

To start cooking

After power on, the buzzer beeps once, all the indicators light up for 1 second then go out, indicating that the induction cooktop has entered the state of standby mode.

- Touch the ON/OFF  control, the buzzer beeps once, indicating that the induction cooktop has entered the state of standby mode, the Power indicator light up.



The unit will automatically return to standby mode if no ON/OFF keys are touched within 30 seconds.

Note: Please do not power off the induction cooktop until the cooling fan has stopped.

- Place a suitable pan on the cooking zone that you wish to use.

Make sure the bottom of the pan and the surface are flat.

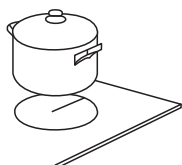

Operating The Cooking Elements

With the cooktop being ON as mentioned above, touch the ON/OFF key pad of the desired cooking element, the Power display will show a "0", indicating no power level for the Element has been set yet, then press the "+" key, "-" key or "B" (Power Boost) key to select a cooking level. The selected cooking element will automatically turn off if no power selection key is not pressed within 30 seconds.

Touch the Minus key (-) to lower the cooking level, the power display will show 1.

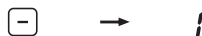

Touch the Minus key (+) to raise the cooking level, the power display will show 9.

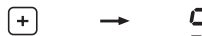

Touch the "B" key, it will show on the display as a "b", boosting the heating power to the highest level for 5 minutes.



Using the Cooktop

Power Boost

The Boost function is used to cook at maximum power for a short period of time (maximum 5 minutes). The power is reduced to level 9 at the end of the maximum boost time.

In the Boost status, touch the "-" key or after 5 minutes, the power boost setting will switch off automatically. Power digital will switch from b to 9.

▲ WARNING: Do not leave a pot unattended while in **Boost Mode or other high power settings**.

STOP/GO

Use the Stop/Go function to 'Pause' the cooktop for Max.5 minutes while cooking; the unit will be automatically switched off if Stop/Go is not touched again within 5 minutes.

To turn on

One or more cooking zones are active. Touch Stop/Go key pad, a "beep" will sound, the indicator light above the Stop/Go will be lit up and all opened Power digital display of the cooktop will show blinking like marching ants.

Any set cooking timers/minute stop, deactivating the "Stop and Go", the countdown will continue.

All of the buttons are inactive except for Stop/Go, Lock control and Main POWER key.

If no any key are touched within 5 minutes, all of the active cooking zones are automatically switched off.

To turn off

Touch Stop/Go key again within 5 minutes, the indicator light above Stop/Go button will go off and the cooktop continues with the settings that were set before the Stop/Go.

Controls Lock



- You can lock the controls to prevent unintended use (for example children accidentally turning the cooking zones on).
- When the controls are locked, all the controls except the Lock control and ON/OFF control are disabled.

To lock the controls

Touch and hold the keylock control  for 3 seconds. The lock indicator will light up.

To unlock the controls

- Make sure the induction hob is turned on.
- Touch and hold the keylock control  for 3 seconds.
- You can now start using your induction hob.

▲ When the hob is in the lock mode, all the controls are disable except the Lock control and ON/OFF , you can always turn the induction hob off with the ON/OFF  control in an emergency, but you shall unlock the hob first in the next operation.

Using the Cooktop

Set Timer

With the desired heating zone Powered ON, select the desired heating zone, then press the  key. The timer display will blink and show a "30", press the "+" or "-" to increase or decrease by 1 minute to the desired time until the desired time appears in the display (Choose up to 99 minutes). Once the Timer is set, if keys haven't been pressed after 5 seconds, it will begin to countdown, the timer display will remain lit, the indicator for that particular burner will flash. When the time is completed, a "beeping" sound will go off indicating that the time is up, and selected heating zone shut off automatically.

If you want to set another burner to switch-off automatically, select desired heating zone, press the  key and repeat the same steps.

If you want to check the remaining time for another zone, select desired heating zone.

If more than one switch-off time is programmed, the shortest time remaining will show in the display, the indicator for that particular burner will flash.

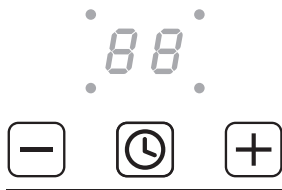

Canceling the Timer

Select the desired heating zone.

Press the  and the indicator will show "--", indicating that the timer of selected heating zone has been canceled.

Over-Temperature Protection

A temperature sensor equipped can monitor the temperature inside the induction hob.

When an excessive temperature is monitored, the induction hob will stop operation automatically.

Auto Shutdown

Another safety feature of the hob is auto shut down. This occurs whenever you forget to switch off a cooking zone. The default shutdown times are 2 hours.

Residual Heat Indicator



Your cooktop has a residual heat indicator  for each Cooking Zone. This indicator will warn that this area has been used and is still giving off enough heat to cause burns.

Avoid touching the burner when this indicator is shown. Although the cooktop is OFF, the  will stay lit until the cooktop has cooled down.

Other Functions

Other Functions

Power Sharing

Your cooktop is equipped with four induction Cooking Zones within two heating sections. The right and left Cooking Zones are powered by two independent induction inverters, one inverter for each of the two heating sections. Two Cooking Zones in a heating section share the power of one inverter. This is called power sharing.

For example, if you are cooking on both right Cooking Zones, the last power level set will be maintained, while the first Cooking Zone may experience a slight reduction in the power level.

Power Sharing Tips

Remember to set the power level for the food item you wish to keep constant last. When using two Cooking Zones, you can maintain a constant power level for two pans on separate heating sections. Place one pan on one of the Cooking Zones of the left heating section and the other pan on one of the Cooking Zones of the right heating section.

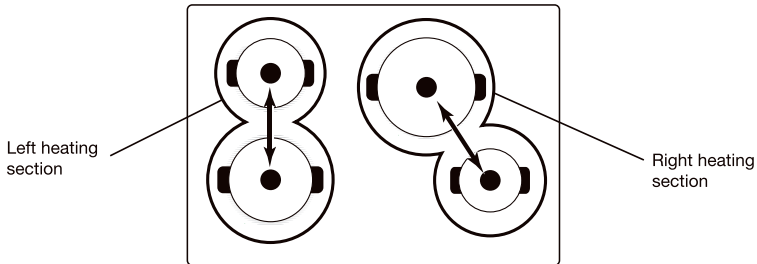

Troubleshooting Error Codes

Troubleshooting



Never repair or modify the hob or disassemble it yourself!



Problems, possible causes and what to do

Problem	Possible cause	What to do
The cooktop cannot be turned on.	No power	Make sure that the hob is properly connected to the power supply and that it is intact. ----- Check whether there is a power outage in your home or area. ----- If you've checked everything and the problem persists, contact a qualified technician.
	Board error	Contact a certified electrician
The touch controls are unresponsive.	The control is locked / The key lock has been activated.	Unlock the control panel. See safety chapter.

Troubleshooting Error Codes

Problem	Possible cause	What to do
The touch controls are difficult to operate.	There is a slight film of water on the controls.	Make sure the touch control area is dry.
	You are using the tip of your finger when touching the controls.	Use the ball of your finger when touching the controls.
Some keys do not work. / The display does not work normally.	Board / display error	Disconnect the hob from the power supply and reconnect it after a short time. If the problem persists, contact a certified electrician.
The power indicator is working, but the heating process does not start.	Overheating of the hob	Ensure that the ventilation paths are not blocked and that the ambient temperature is not too high.
	The cooling fan is not working.	Contact a certified electrician
	Technical error	
The cookware is not heated and the  icon is displayed.	The cookware is not suitable for induction or is not detected.	Use induction-suitable cookware in a size suitable for the desired cooking zone and position it correctly. See the cookware chapter.
Operation stops suddenly and the  icon is displayed.	The automatic detection function has failed.	Contact a certified electrician
The  icon is displayed for two cooking zones placed one behind the other (1+2 / 3+4)	Technical error	Contact a certified electrician

Troubleshooting Error Codes

Problem	Possible cause	What to do
The glass is being scratched.	Rough-edged cookware is used.	Use cookware with flat and smooth bottom. See the chapter regarding right cookware.
	Unsuitable, abrasive scourer or cleaning products are being used.	See the cleaning chapter.
Some pans or pots make crackling or clicking noises.	This may be caused by the construction of your cookware (layers of different metals vibrating differently).	This is harmless and normal.
A slight humming noise can be heard when operating at high power.	This can be caused by induction technology.	This is normal, but the noise should quiet down or disappear completely by reducing the power level.
Fan noise	A cooling fan integrated in the hob prevents the electronics from overheating. If necessary, it continues to run even after the hob is switched off.	This is normal and necessary for error-free operation. Do not disconnect the appliance from the power supply while the fan is running.
abnormal fan noise	The cooling fan is damaged.	Contact a certified electrician
The hob or cooking zone switches off suddenly, a signal tone is heard and an error code is displayed.	Technical error / Code meaning see following table	Note down the error code, disconnect the hob from the power supply and contact a certified electrician.

Troubleshooting Error Codes

Error codes

Error code	Meaning	What to do
E1	No suitable cookware was identified	Place suitable cookware in the middle of the corresponding cooking zone (see chapter on cookware)
E2	The voltage is too low (less than 85 V)	Check the power supply. If it is normal, turn the hob back on.
E2	The voltage is too high (higher than 285 V)	
E3	Error message of the cooktop sensor / short circuit	Contact the customer service or a certified electrician.
E4	Error message of the IGBT-sensor / short circuit	
E5	Overheating of the hob	Wait until the hob has cooled down and then switch it on again.
E6	IGBT overheating	Wait until the hob has cooled down and then switch it on again.
E7	Malfunction of the cooktop sensor	Contact the customer service or a certified.
E7	Communication failure between display and mainboard	
E8	Overflow protection	Remove spilled liquids and switch the hob back on.

Warranty

Dear Customer,

Thank you for choosing TRIFECTE product. We sincerely hope that you are satisfied with it. The manufacturer's warranty covers the product for a period of **12 months** from the date of purchase against manufacturing faults.

Any question or problem, please feel free to contact us at **cs@trifecte.com**.

Notice:

1. Please write down your order number and purchase channel.
2. Would be better and faster to solve your problem if you could attach videos or pictures.
3. The warranty only applies to the original purchase and starts from the original purchase date. Any replacement will be considered as a part of the original purchase.

The following situations may result in the manufacturer not providing warranty coverage:

1. Expired warranty period: Induction cookers have a specified warranty period of 1 year, and once it expires, the manufacturer will no longer offer free repair or replacement services.
2. Damage caused by human factors: If the induction cooker malfunctions due to human errors such as incorrect usage, disassembly, modification, accidental damage, or improper repairs, the manufacturer typically will not provide warranty coverage.
3. Improper usage environment: If the induction cooker is used in unsuitable conditions, such as high temperatures, humidity, or corrosive gases, it may lead to damage, and in such cases, the manufacturer may not provide warranty coverage.
4. Natural disasters or accidents: If the induction cooker is damaged due to natural disasters (such as earthquakes, fires, floods) or accidents (such as falls, collisions), it is typically not covered by the warranty.
5. Unauthorized repairs: If the induction cooker is repaired or serviced by unauthorized personnel during the warranty period, it may render the warranty void.