



**INSTRUCTIONS D'ASSEMBLAGE
ASSEMBLY INSTRUCTIONS**

**TABLE D'APPOINT -
22"H / GRIS / METAL NOIR / VERRE TREMPE**

**ACCENT TABLE -
22"H / GREY / BLACK METAL / TEMPERED GLASS**



**POUR DE L'ASSISTANCE OU POUR COMMANDER
DES PIÈCES CONTACTEZ NOTRE DÉPARTEMENT
DE SERVICE À LA CLIENTÈLE.**

**FOR ASSISTANCE OR TO ORDER PARTS
CONTACT OUR CUSTOMER SERVICE DEPARTMENT**

LISTE DES PIÈCES PARTS LIST

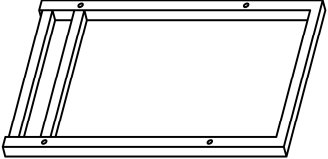
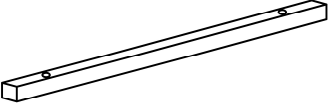
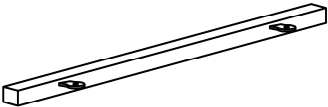
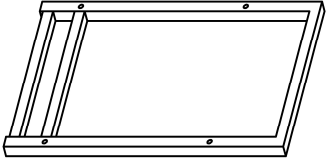
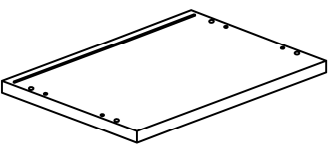

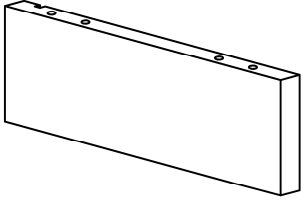
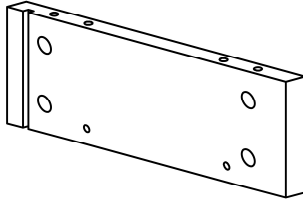
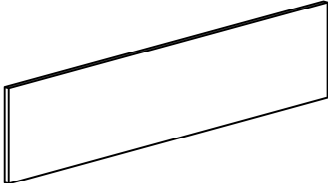
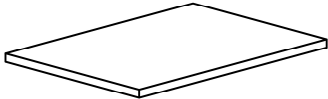
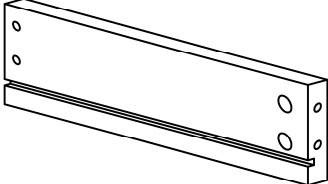

PIÈCE / PART #	IMAGE	DESCRIPTION	QTY / QTÉ
1		FRONT FACING LEFT LEG PATTE AVANT GAUCHE	1
2		CROSSBAR BARRE TRANSVERSALE	2
3		CROSSBAR BARRE TRANSVERSALE	2
4		FRONT FACING RIGHT LEG PATTE AVANT DROITE	1
5		BOTTOM PANEL PANNEAU DU BAS	1

LISTE DES PIÈCES PARTS LIST

PIÈCE / PART #	IMAGE	DESCRIPTION	QTY / QTÉ
6		FRONT FACING LEFT SIDE PANEL PANNEAU DE CÔTÉ GAUCHE	1
7		FRONT FACING RIGHT SIDE PANEL PANNEAU DE CÔTÉ AVANT DROIT	1
8		BACK PANEL PANNEAU ARRIÈRE	1
9		TOP PANEL PANNEAU DE SURFACE	1
10		DRAWER SIDE PANEL PANNEAU DE CÔTÉ TIROIR	1

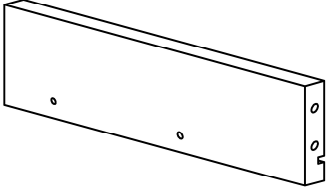
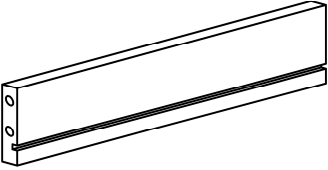
LISTE DES PIÈCES

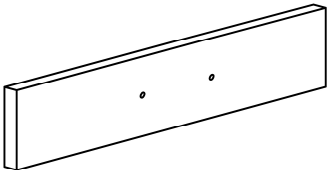
PARTS LIST

PIÈCE / PART #	IMAGE	DESCRIPTION	QTY / QTÉ
11		DRAWER SIDE PANEL PANNEAU DE CÔTÉ TIROIR	1
12		DRAWER BACK PANEL PANNEAU ARRIÈRE TIROIR	1
13		DRAWER BOTTOM PANEL PANNEAU DU BAS TIROIR	1
14		DRAWER FRONT PANEL PANNEAU AVANT TIROIR	1
15		GLASS PANEL PANNEAU EN VERRE	1

LISTE DES PIÈCES DE MONTAGE HARDWARE LIST

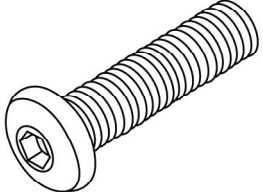
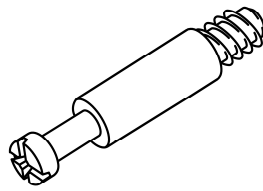
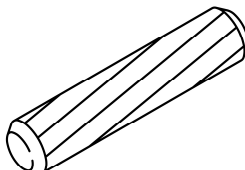
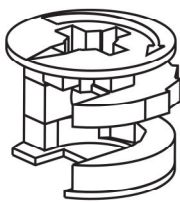
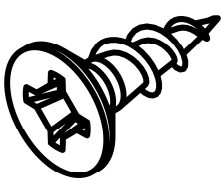
PIÈCE / PART #	IMAGE	DESCRIPTION	QTY / QTÉ
A		ASSEMBLING BOLT - 1 1/8" BOULON D'ASSEMBLAGE - 1 1/8"	8
B		CAM LOCK SCREW VIS CAM LOCK	16
C		WOOD DOWEL GOUJON DE BOIS	8
D		CAM LOCK CONNECTOR ÉCROU CAM LOCK	16
E		ASSEMBLING SCREW - 1/2" VIS D'ASSEMBLAGE - 1/2"	8

LISTE DES PIÈCES DE MONTAGE HARDWARE LIST

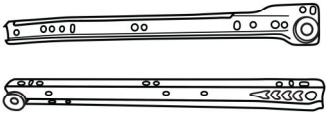
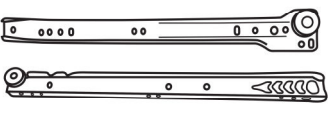
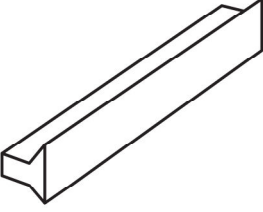
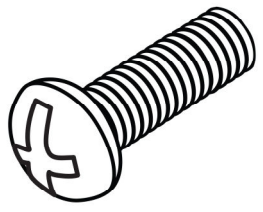
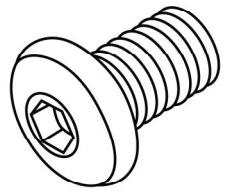
PIÈCE / PART #	IMAGE	DESCRIPTION	QTY / QTÉ
F		METAL DRAWER SLIDE COULISSE DE MÉTAL	1
G		METAL DRAWER SLIDE COULISSE DE MÉTAL	1
H		HANDLE POIGNÉE	1
I		ASSEMBLING BOLT - 3/4" BOULON D'ASSEMBLAGE - 3/4"	2
J		ASSEMBLING BOLT - 1" BOULON D'ASSEMBLAGE - 1"	4

LISTE DES PIÈCES DE MONTAGE
HARDWARE LIST

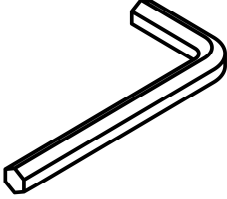
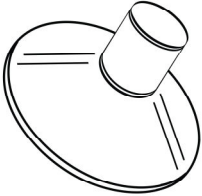
PIÈCE / PART #	IMAGE	DESCRIPTION	QTY / QTÉ
K		HEX KEY CLÉ HEXAGONALE	1
L		SUCTION CUP VENTOUSE	4

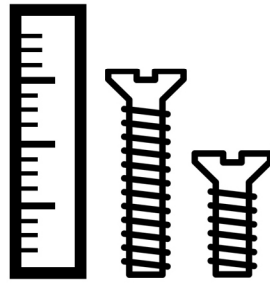

OUTIL DE VÉRIFICATION DE DIMENSIONS DES PIÈCES
HARDWARE DIMENSIONS VERIFICATION TOOL



ÉTAPE / STEP 1

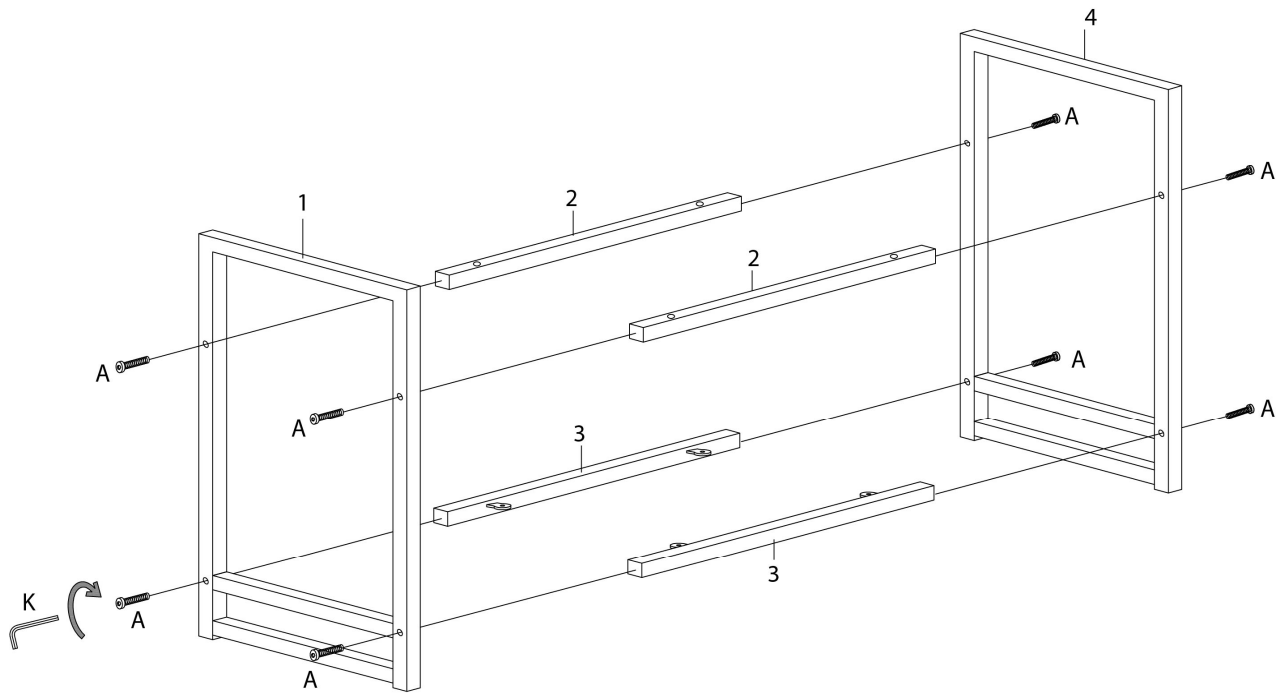

ÉTAPE / STEP 2

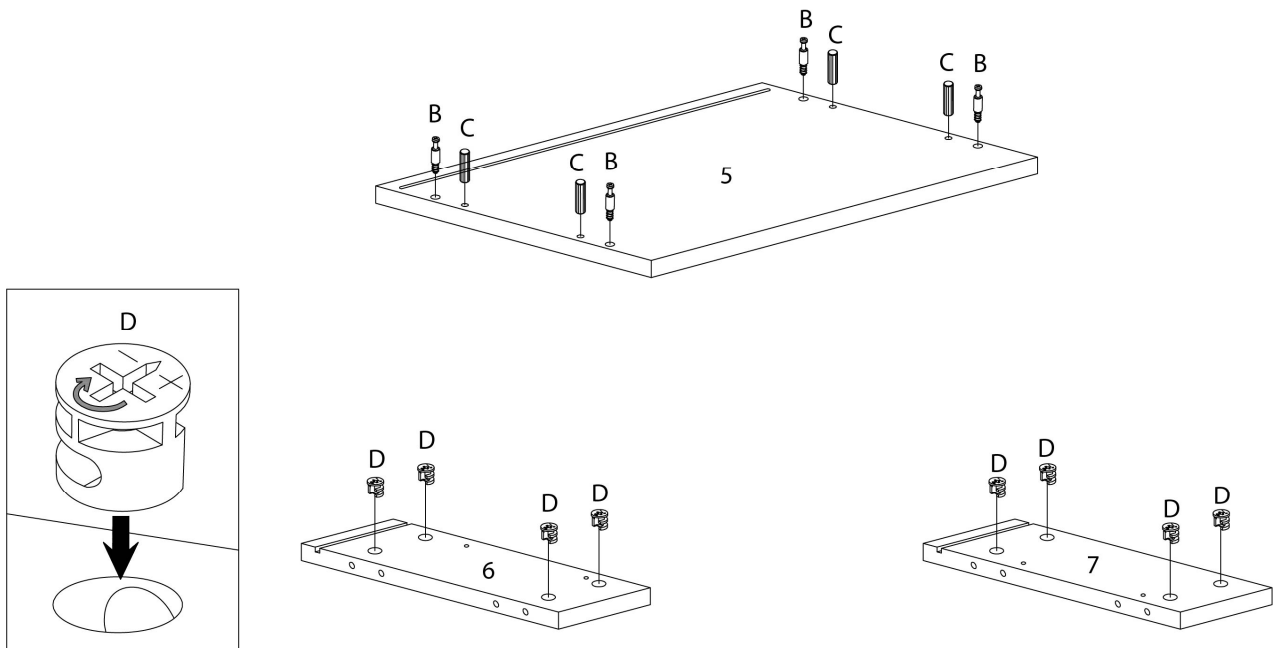

ÉTAPE / STEP 3

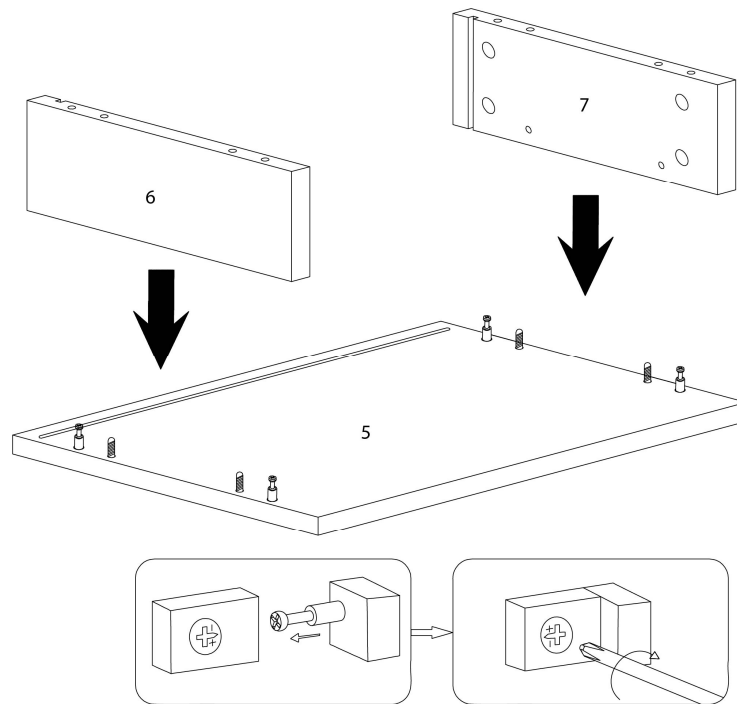

ÉTAPE / STEP 4

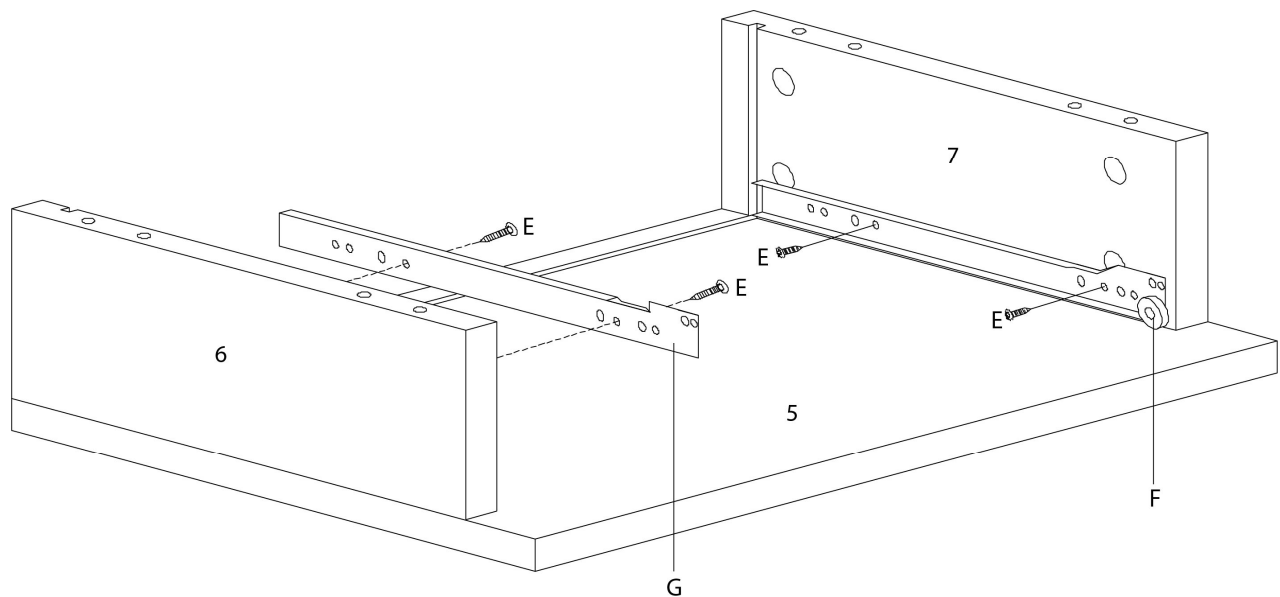

ÉTAPE / STEP 5

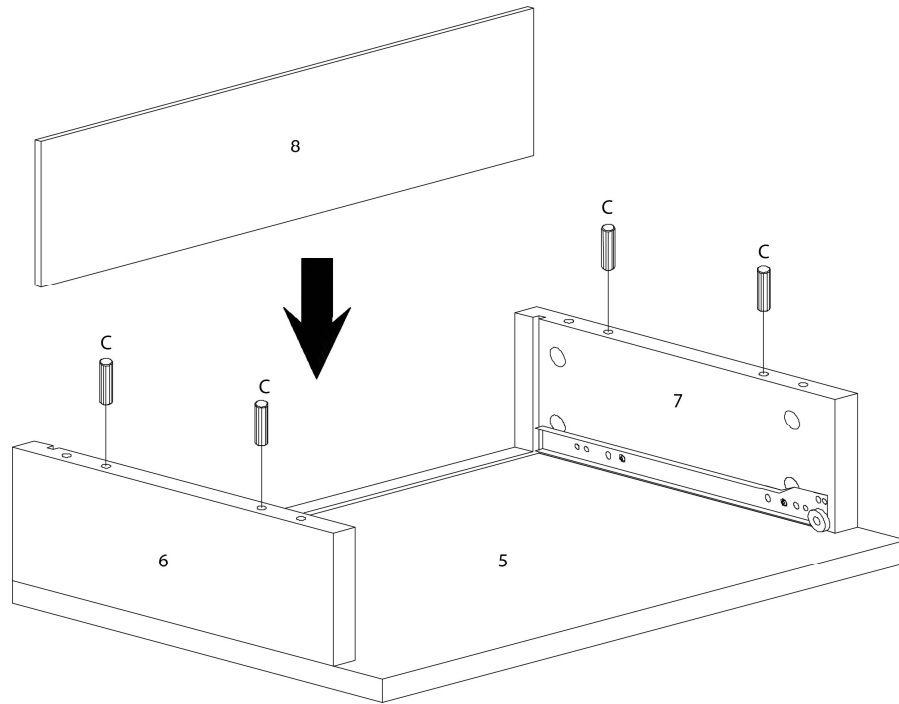

ÉTAPE / STEP 6

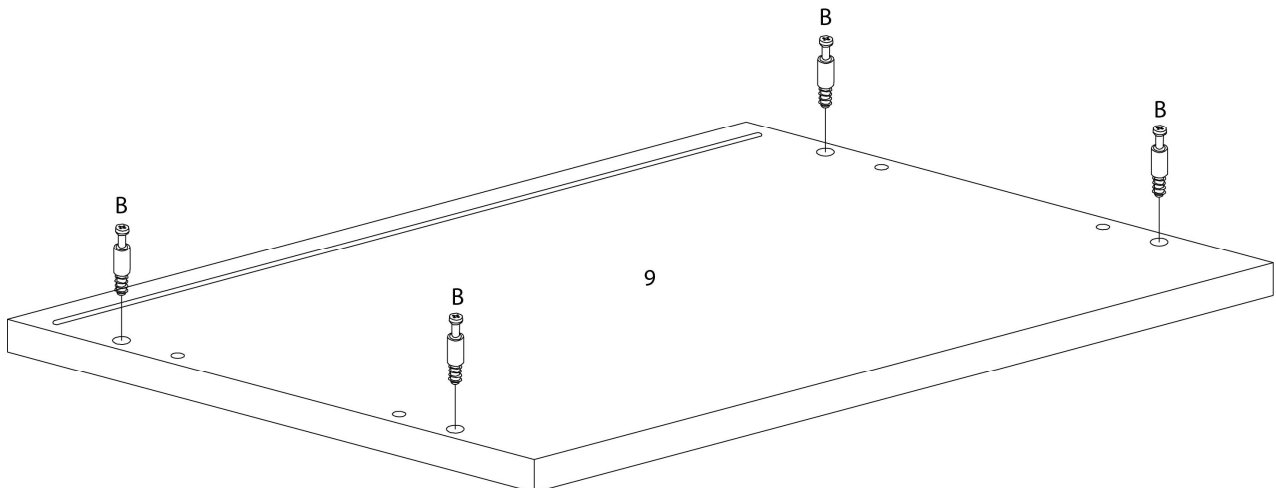

ÉTAPE / STEP 7

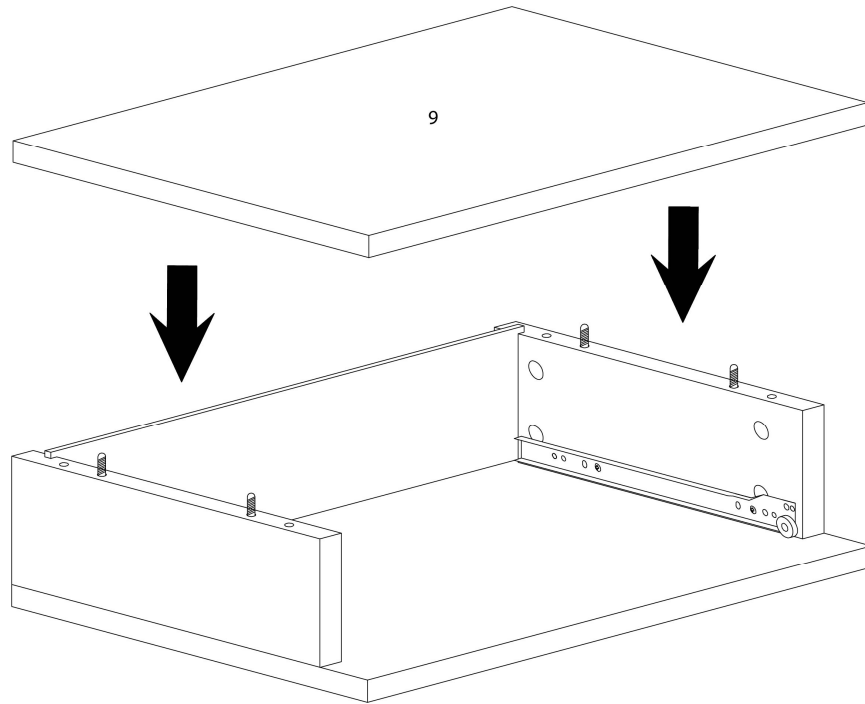

ÉTAPE / STEP 8

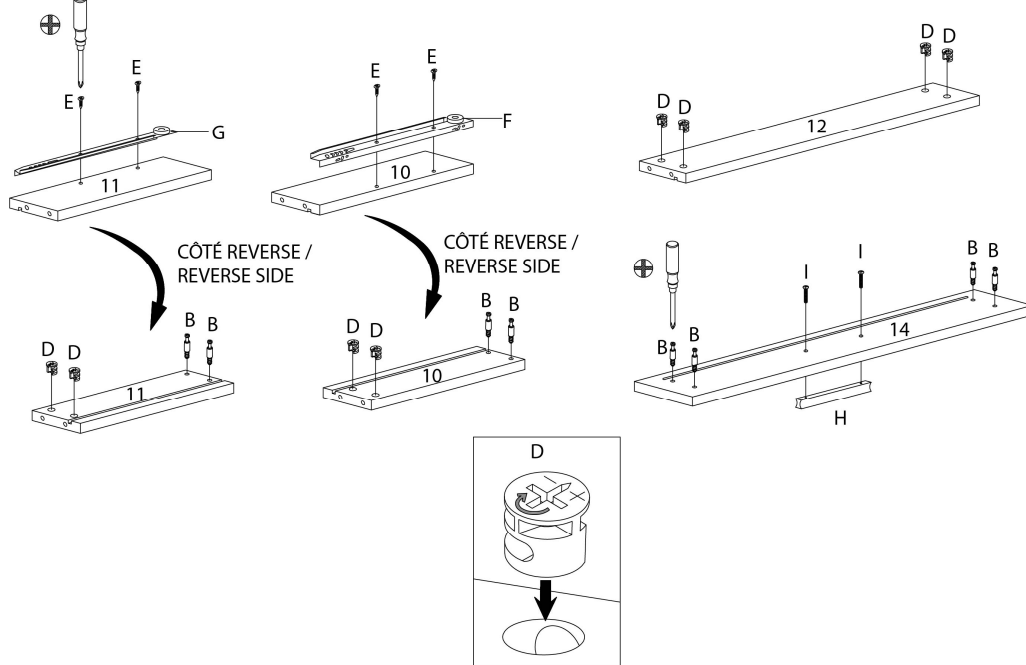

ÉTAPE / STEP 9

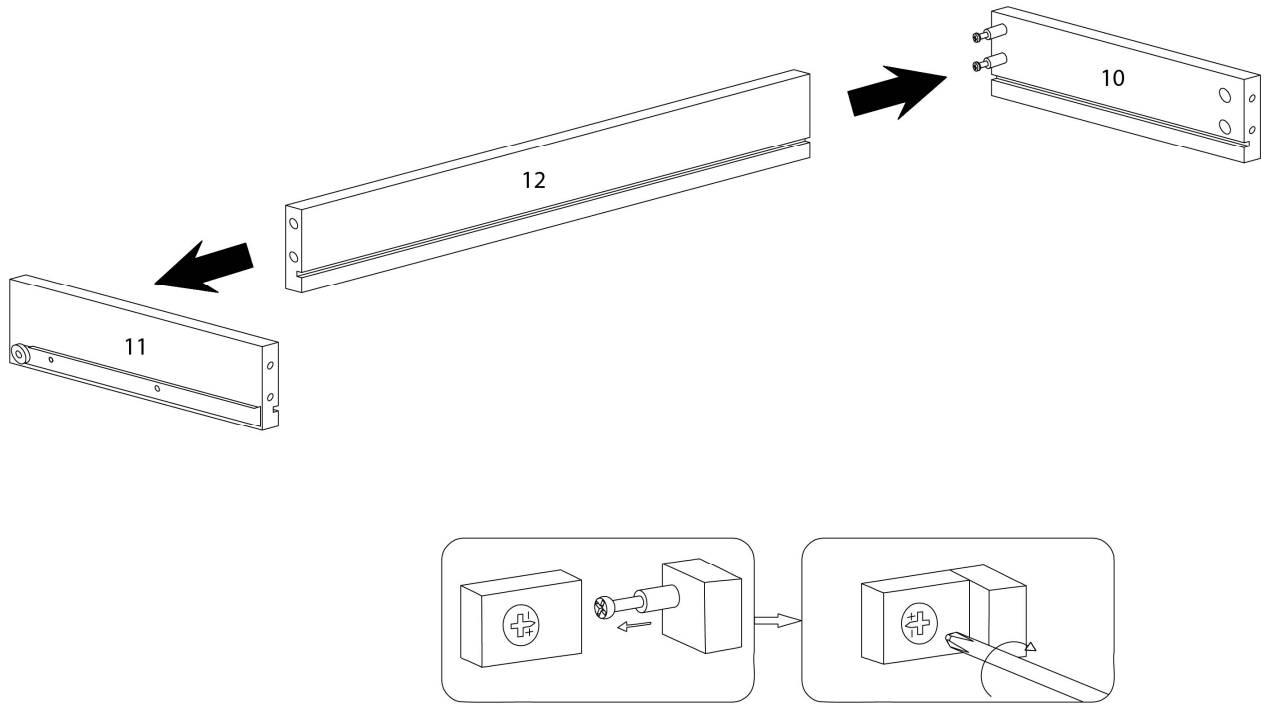

ÉTAPE / STEP 10

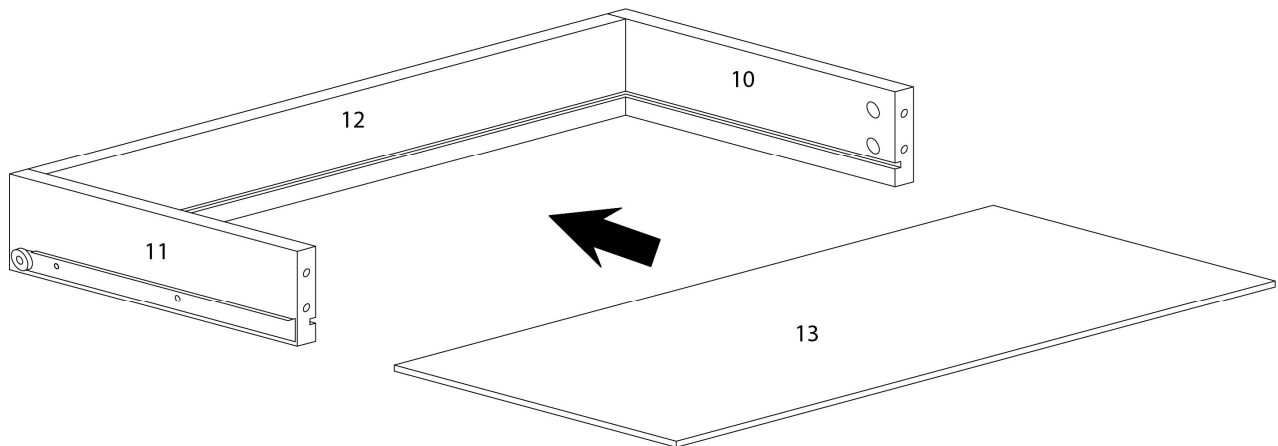

ÉTAPE / STEP 11

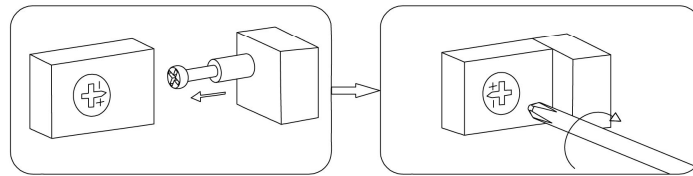
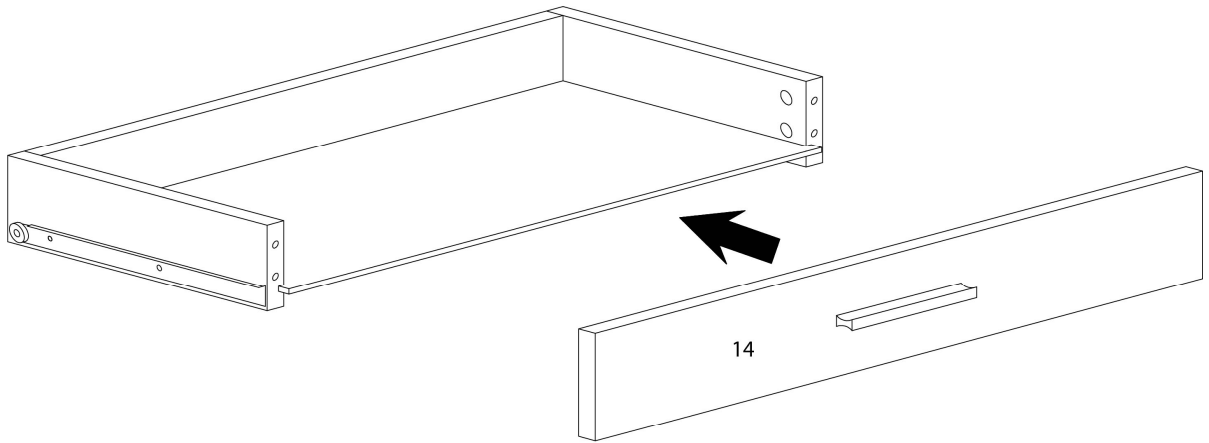

ÉTAPE / STEP 12

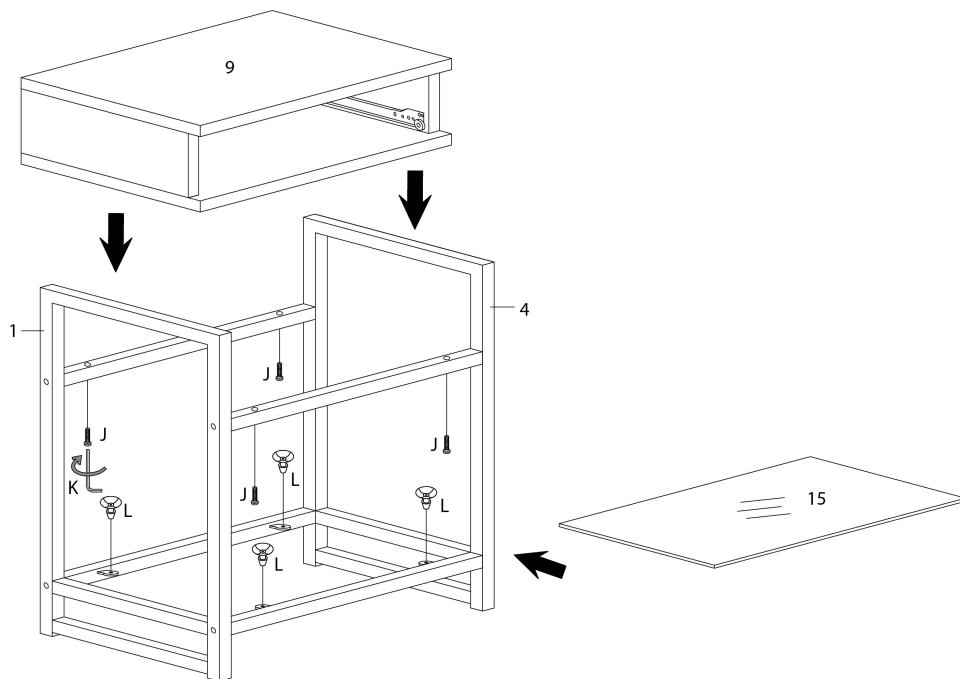

ÉTAPE / STEP 13

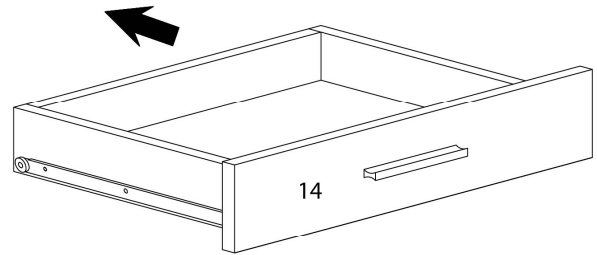
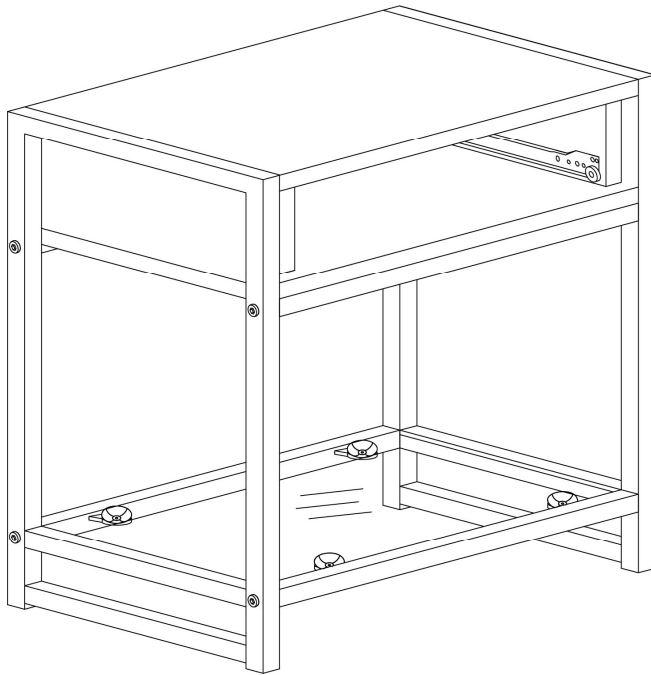

ÉTAPE / STEP 14

