

# Assembly Instruction

**Tools Required:** Flathead screwdriver, Phillips screwdriver, pliers, wire cutters, wire strippers, electrical tape, safety glasses.

**Bulb Recommended:** (2) Candelabra Base 60W Maximum, Alternate bulb (2) 13W CFL

**Estimated Assembly Time:** 30-45 minutes

**Preparation:** Identify and inspect all parts before beginning installation. Check package content list and diagrams below to be sure all parts are present. If any parts are missing or damaged, do not attempt to assemble, install, or operate the fixture. Contact customer service for replacement parts.

**Fixture can only be mounted in the direction indicated on page 2.**

## ⚠ Warnings and Cautions

Turn off electricity at circuit breaker or main fuse box before installation. Consult a licensed electrician if in doubt.

These instructions are provided for your safety. It is very important you read them completely before installing the fixture. We strongly recommend that a licensed, professional electrician perform the installation.

Disconnect fixture from power source before replacing bulbs. Make sure bulbs are given sufficient time to cool before removal. Do not subject glass parts to any shock while in operation or shattering may result.

## Package Contents

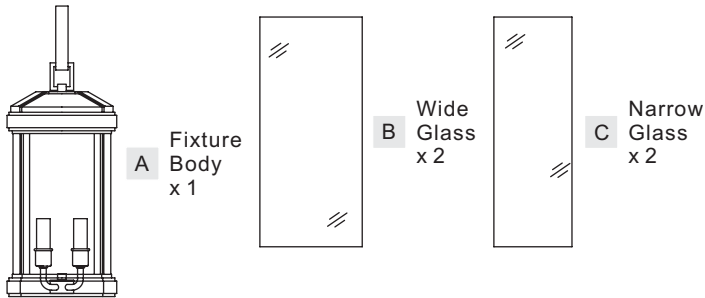

- B. Connect White Supply Wire from the Outlet Box to Ribbed side Wire from fixture.
- C. Connect Black (or Red) Supply Wire from the Outlet Box to Smooth side Wire from fixture.
- D. Connect Ground Wire from the Outlet Box to Ground Wire from fixture.
- E. Twist connectors until wires are tightly joined together.
- F. Wrap each connection with approved electrical tape and carefully stuff all the connected wires into the Outlet Box.

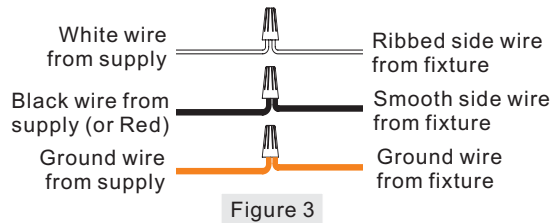

## Hardware Contents

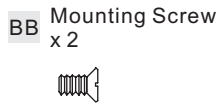
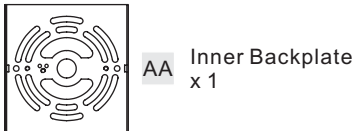

## STEP 1 - Attach Glass to Fixture Body

- A. Insert the Wider Glass (B) Panel to the Cage close to the backplate first. Then insert the two Narrow Glasses (C) to the cage next to the installed wider glass. Insert the other Wider Glass (B) to the cage at last.

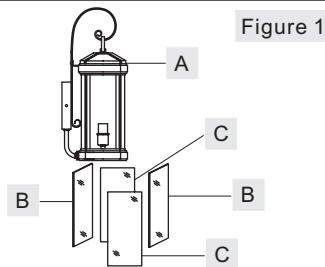

## STEP 2 - Install Bulb

- A. This fixture uses candelabra bulb with a candelabra screw base. Maximum 60 watts.
- B. Insert bulb and screw snugly into place.

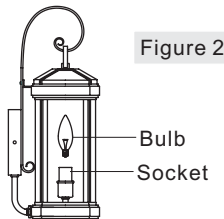

## STEP 3 - Wire Connections

- A. Use standard wire connectors (not included) to make all wire connections. (Connectors are not included with fixture.) Strip and prepare wire ends according to instructions supplied with connectors.

## STEP 4 - Attach fixture to Inner Backplate

- A. Place the backplate of the Fixture Body (A) onto the Inner Backplate (AA). Line up holes on both of them. Thread Mounting Screws (BB) into the mounting holes on the Inner Backplate (AA) and hand tighten until snug to secure them.

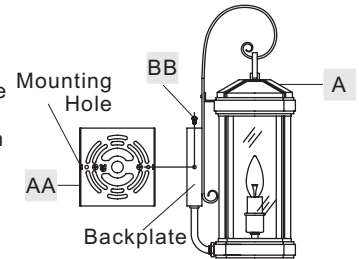

## STEP 5 - Apply Silicone Sealer

- A. Make sure exterior wall surface and fixture backplate are free of dirt before applying caulk. Using exterior grade caulk, caulk over top of backplate and down other side. Do not caulk bottom of fixture backplate to ensure proper moisture drainage.

Your fixture is now assembled and ready to use. Enjoy!

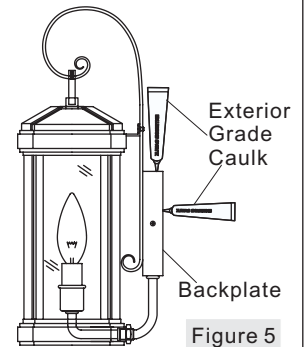

FINISH: MYSTIC BLACK

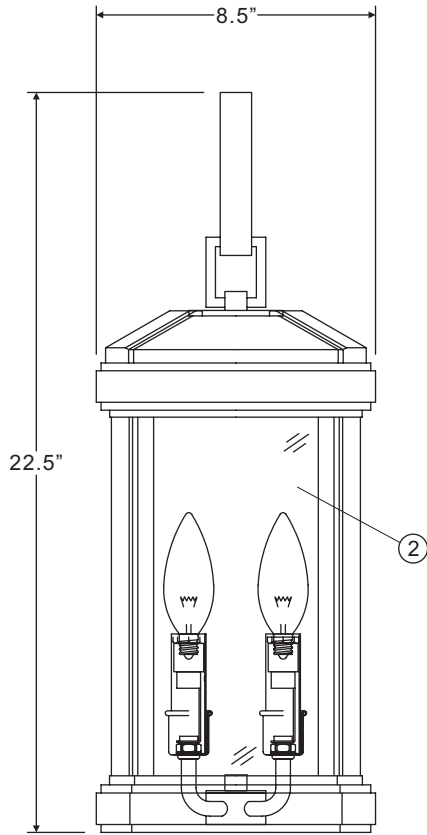
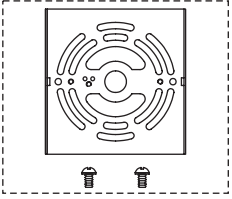

↑  
Fixture can only be mounted in the direction indicated

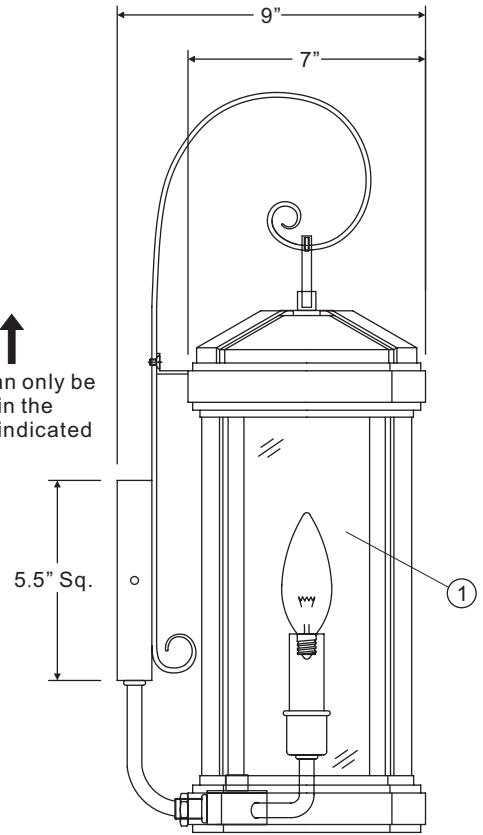

(2) 60W Candelabra base bulbs  
(Not Supplied)

NOTE: ALL DIMENSIONS ARE ROUNDED UP TO THE NEAREST 1/2"

REPLACEMENT PART DESCRIPTION	REQ.
CLEAR SEEDY GLASS PANEL 11.5"L x 4.25"W	2
CLEAR SEEDY GLASS PANEL 11.5"L x 5.5"W	2