

ASSEMBLY INSTRUCTIONS

Item No : WF294587AAG

Description : QUEEN BED

Thank you for purchasing this quality product. Be sure to check all packing material carefully for small part that may have come loose inside carton during shipment.

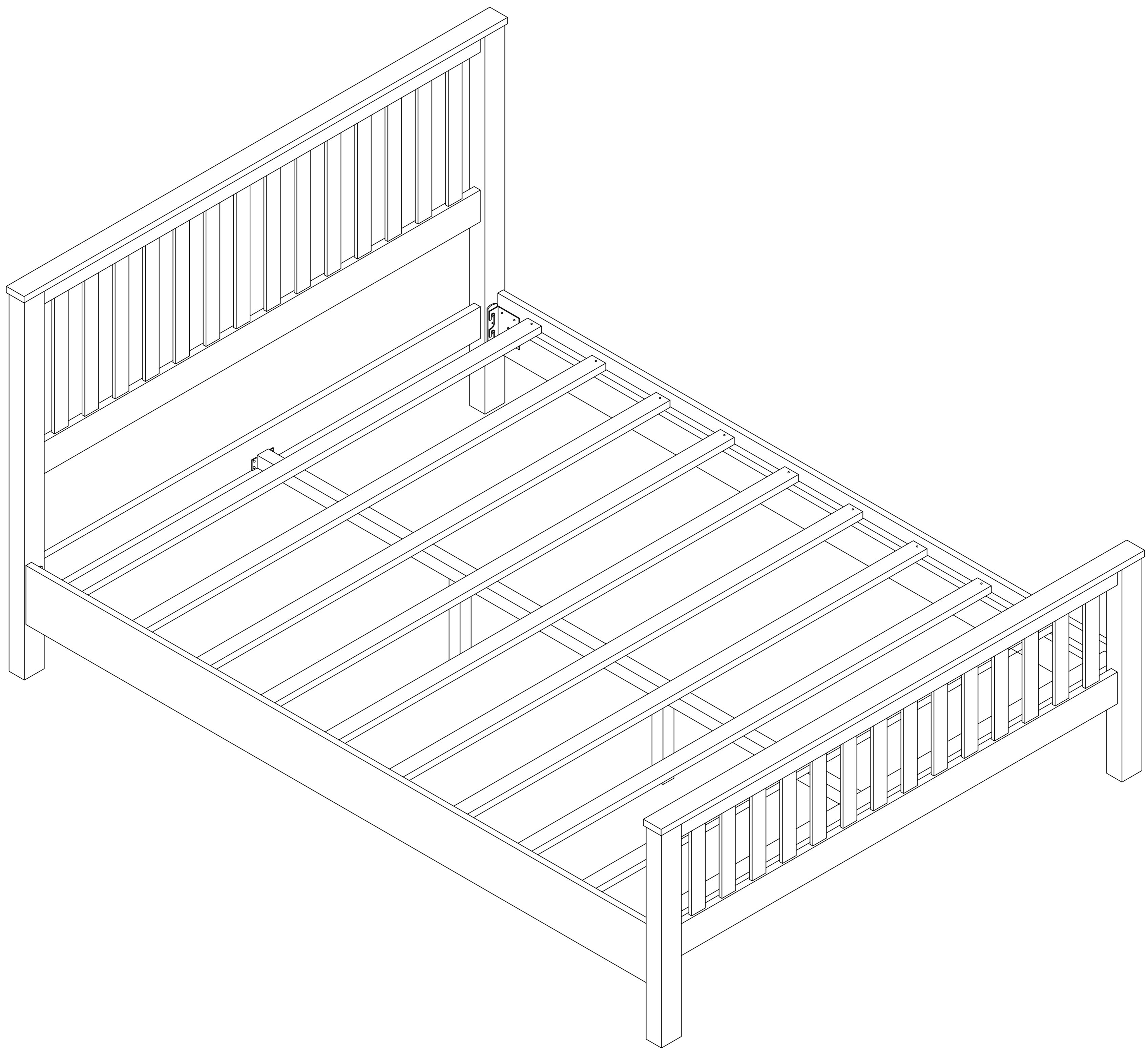

WF294587AAG

ASSEMBLY INSTRUCTIONS

Item No : WF294587AAG

Description : QUEEN BED

Thank you for purchasing this quality product. Be sure to check all packing material carefully for small part that may have come loose inside carton during shipment.

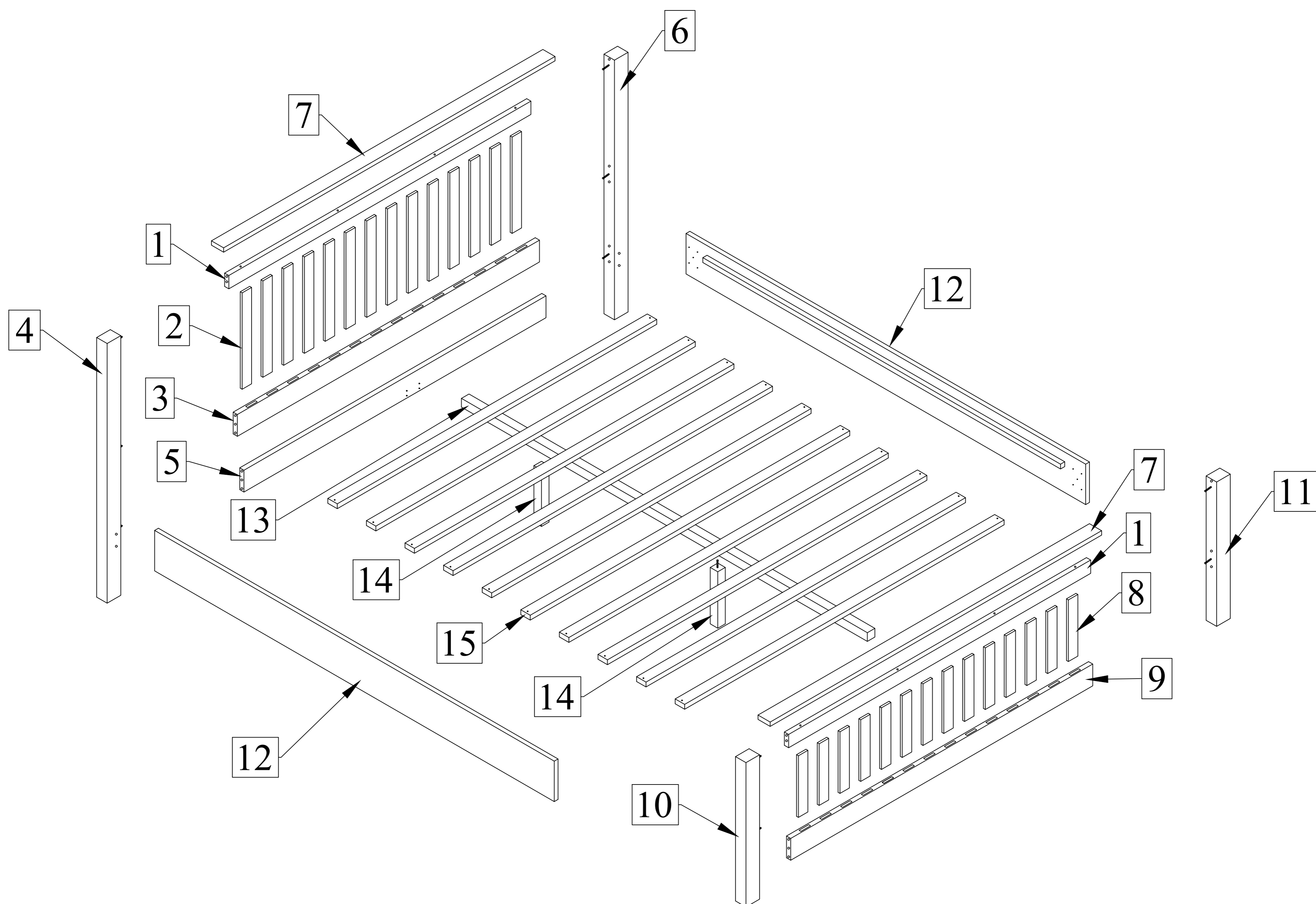

TOOLS REQUIRED (Not provided)

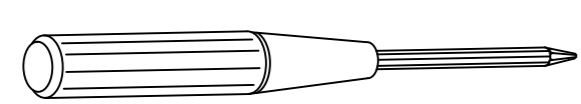

Screwdriver

Hardware List

No.	Description	Sketch	Quantity
A	Wood Dowel M8x30MM		16PCS
B	U Bracket		2PCS
C	Screw M3.5 x 16MM		44PCS
D	Minifix + Cap		8SETS
E	Iron Plate		4PCS
F	Bed Bracket - 2L2R		4PCS
G	Hex Nut		10PCS
H	Spring Washer		10PCS
I	Spanner		1PC
J	Bolt		8PCS
K	Allen Key M5		1PC
L	Screw M4 x 32MM		20PCS

Part List

No.	Description	Sketch	Quantity
1	Upper Slats Support		2PCS
2	HB Slats		14PCS
3	Lower Slats Support - HB		1PC
4	HB Pillar - L		1PC
5	HB Support Rail		1PC
6	HB Pillar - R		1PC
7	Top Panel		2PCS
8	FB Slats		14PCS
9	Lower Slats Support - FB		1PC
10	FB Pillar - L		1PC
11	FB Pillar - R		1PC
12	Bed Side Rail		2PCS
13	Center Support Rail		1PC
14	Center Support Leg		2PCS
15	Bed Slats		10PCS

ASSEMBLY INSTRUCTIONS

Item No : WF294587AAG

Description : QUEEN BED

Thank you for purchasing this quality product. Be sure to check all packing material carefully for small part that may have come loose inside carton during shipment.

Step 1 : Attach Wood Dowel M8 x30 MM (A) to Upper Slats Support (1), Lower Slats Support - HB (3), HB Support Rail (5) and Lower Slats Support - FB (9). Attach U Bracket (B), Iron Plate (E), and Bed Bracket (F) to parts (4,5,6,9,10,11,12) accordingly using Screw M3.5 x 16MM (C). Attach Minifix (D) to Top Panel (7).

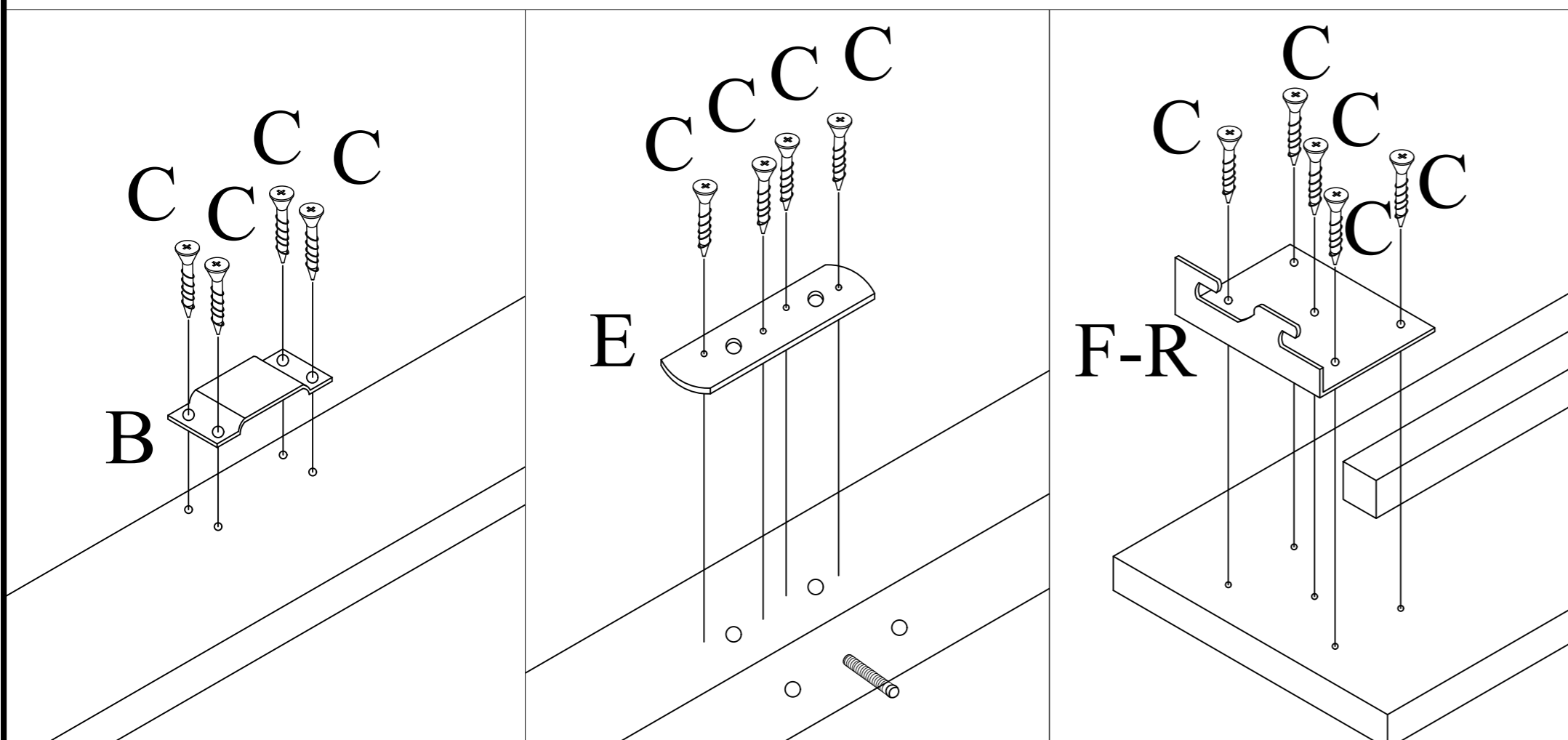
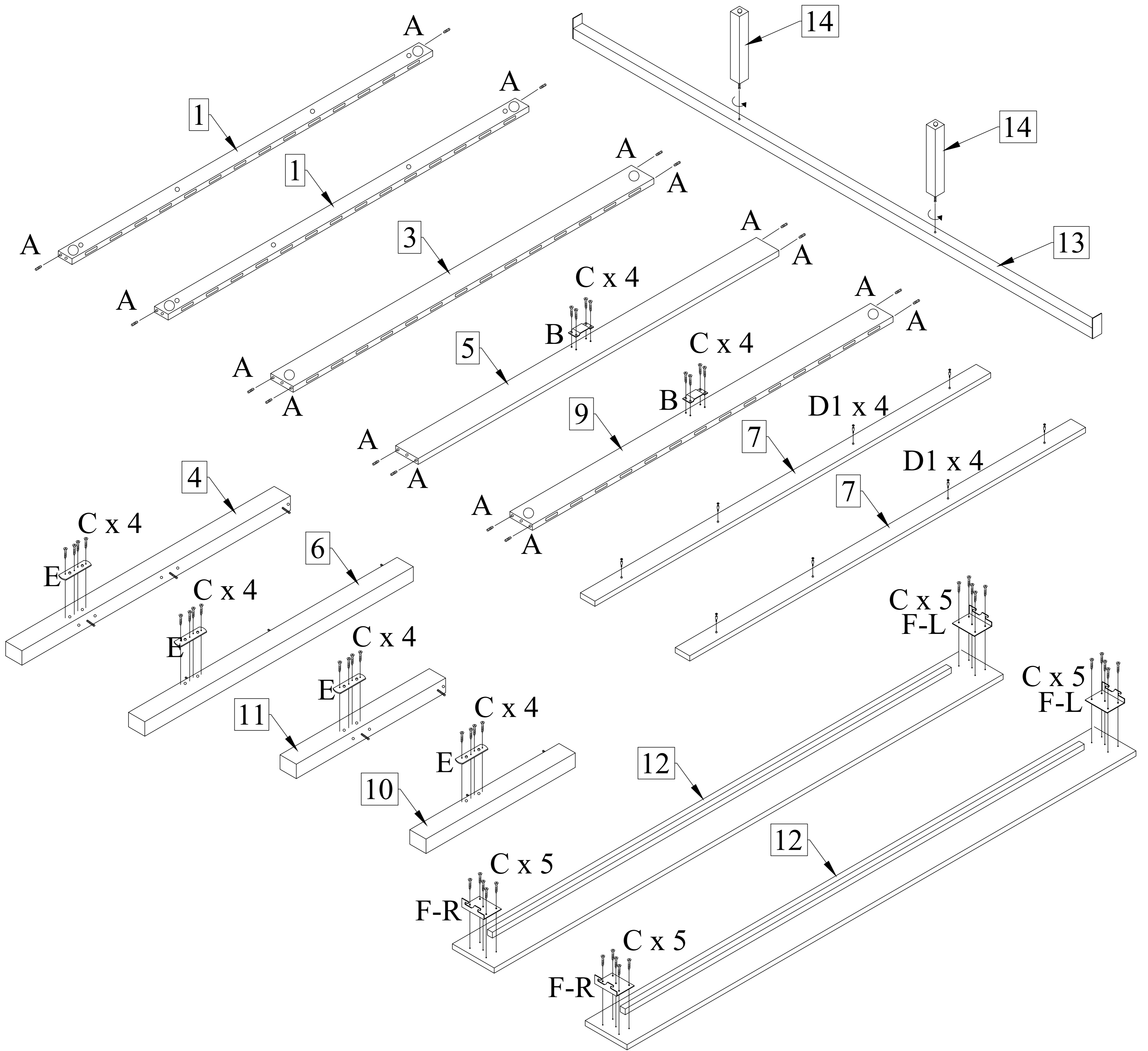

A	Wood Dowel M8x30MM		16PCS
B	U Bracket		2PCS
C	Screw M3.5x16MM		44PCS
D	Minifix	D1	8PCS
E	Iron Plate		4PCS
F	Bed Bracket - 2L2R	FL FR	4PCS

ASSEMBLY INSTRUCTIONS

Item No : WF294587AAG

Description : QUEEN BED

Thank you for purchasing this quality product. Be sure to check all packing material carefully for small part that may have come loose inside carton during shipment.

Step 2 :Headboard (HB) assembly.





First slot in HB slats (2) to Upper Slats Support (1), then slot the Lower Slats Support - HB (3) in.

Attach the connected parts and HB Support Rail (5) to HB Pillar - L (4) and lock with Hex Nut (G) and Spring Washer (H) using Spanner (I) provided.

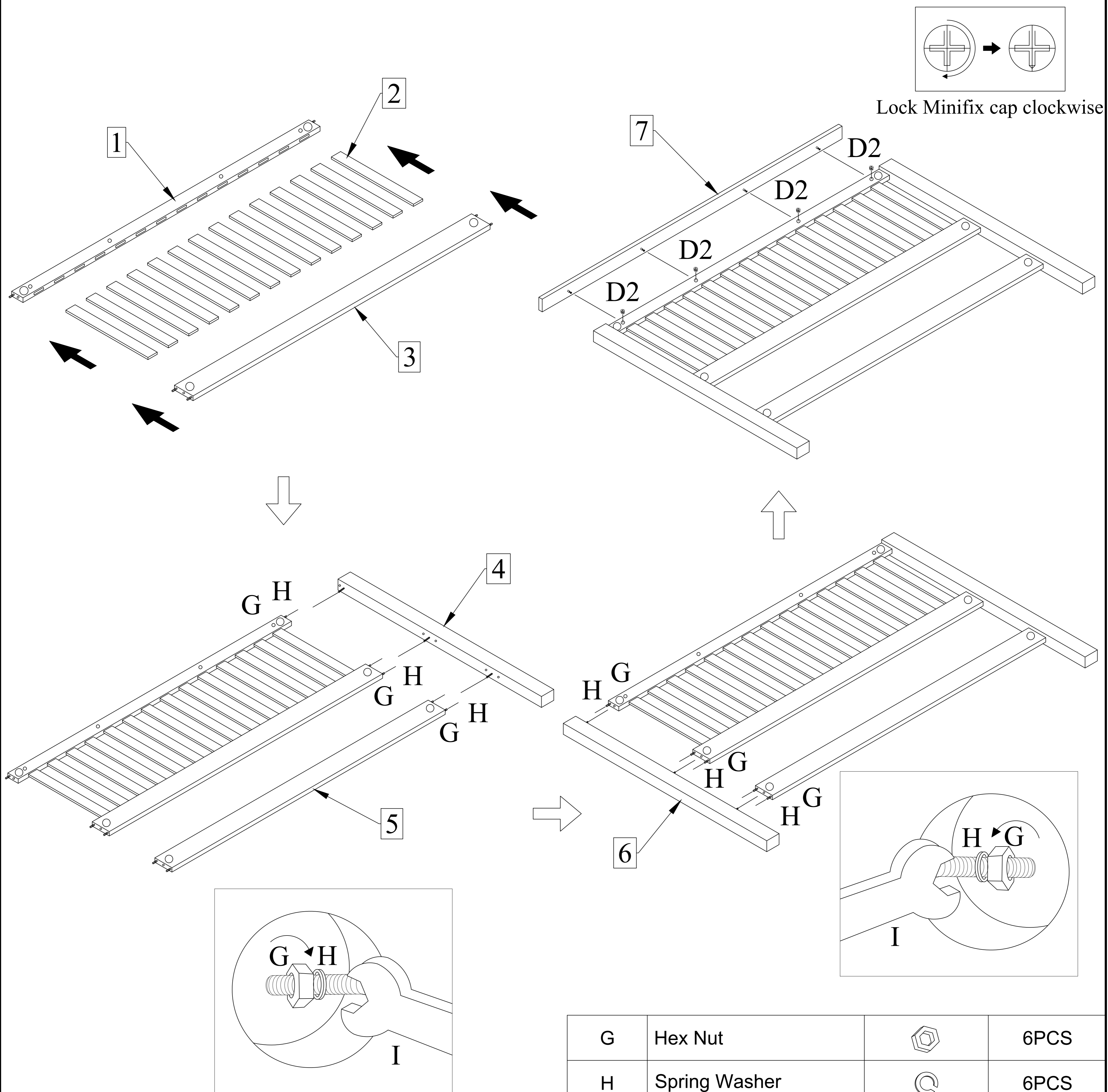
Attach the connected parts again to HB Pillar - R (6) and lock with Hex Nut (G) and Spring Washer (H) using Spanner (I) provided.

Finally, connect Top Panel (7) to the Headboard and lock with Minifix Cap (D2)

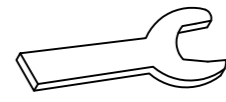

G	Hex Nut		6PCS
H	Spring Washer		6PCS
I	Spanner		1PC
D	Minifix Cap	D2 	4PCS

ASSEMBLY INSTRUCTIONS

Item No : WF294587AAG

Description : QUEEN BED

Thank you for purchasing this quality product. Be sure to check all packing material carefully for small part that may have come loose inside carton during shipment.

Step 3 :Footboard (FB) assembly.





First slot in FB slats (8) to Upper Slats Support (1), then slot the Lower Slats Support - FB (9) in.

Attach the connected parts to FB Pillar - L (10) and lock with Hex Nut (G) and Spring Washer (H) using Spanner (I) provided.

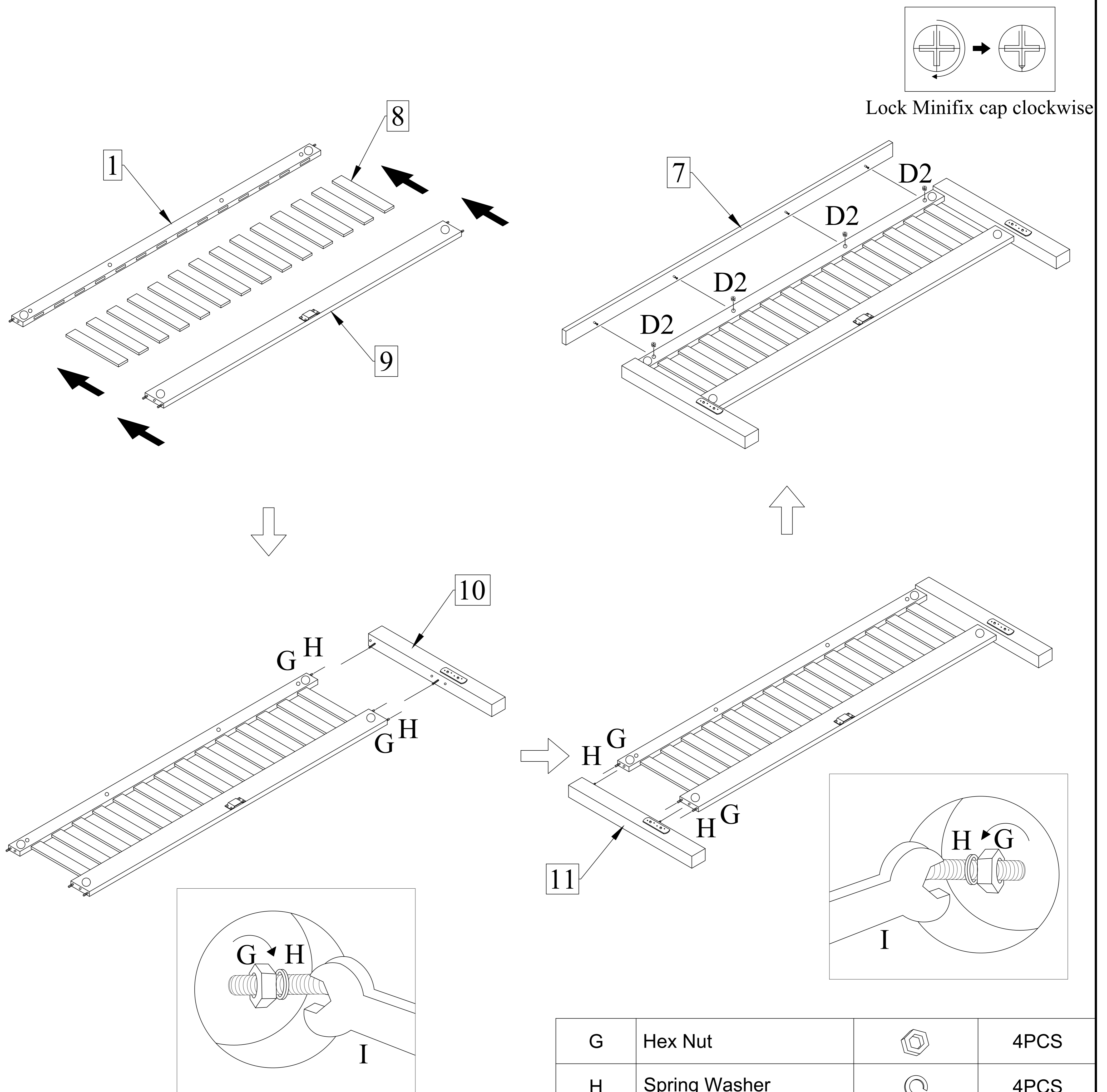
Attach the connected parts again to FB Pillar - R (11) and lock with Hex Nut (G) and Spring Washer (H) using Spanner (I) provided.

Finally, connect Top Panel (7) to the Footboard and lock with Minifix Cap (D2)

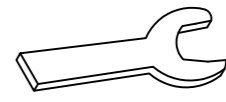

G	Hex Nut		4PCS
H	Spring Washer		4PCS
I	Spanner		1PC
D	Minifix Cap	D2 	4PCS

ASSEMBLY INSTRUCTIONS

Item No : WF294587AAG

Description : QUEEN BED

Thank you for purchasing this quality product. Be sure to check all packing material carefully for small part that may have come loose inside carton during shipment.

Step 4 : Connect Bed Side Rails (12) to Headboard and Footboard with Bolt (J) using Allen Key M5 (K)

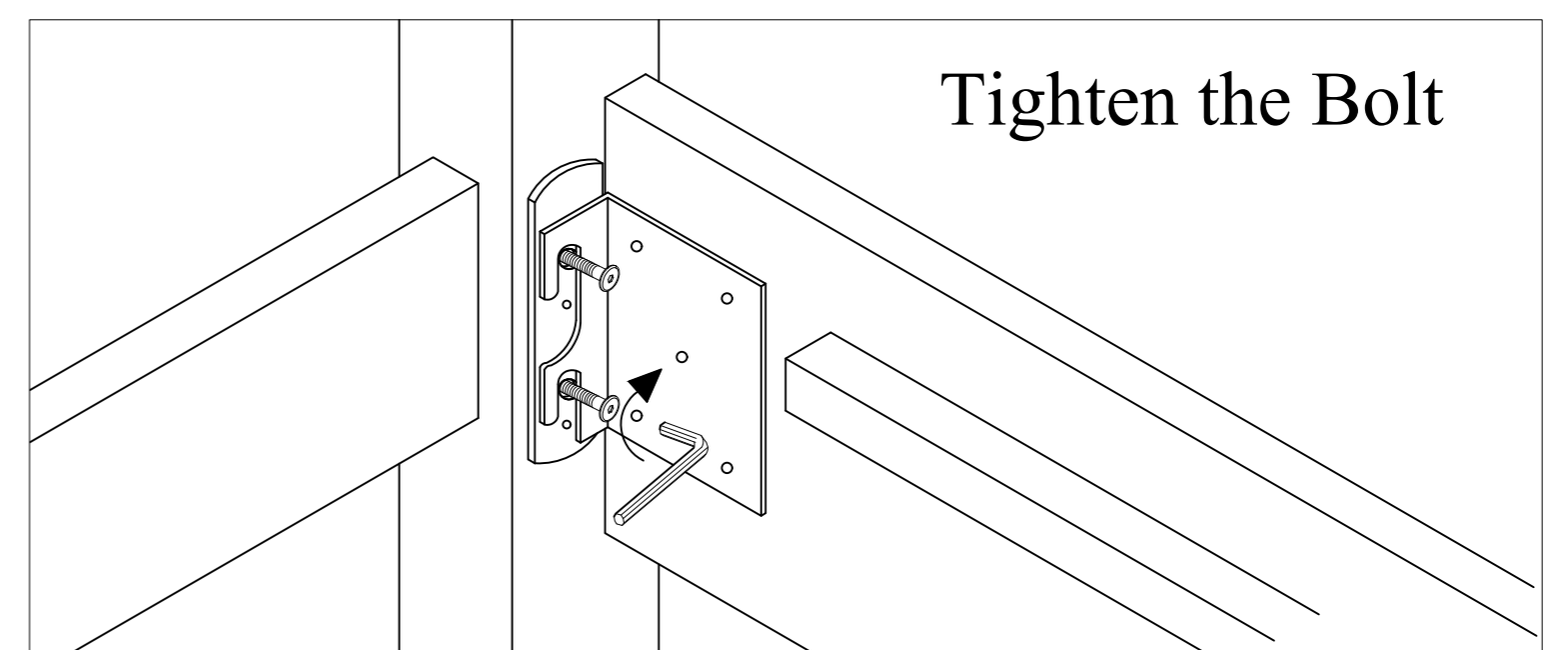
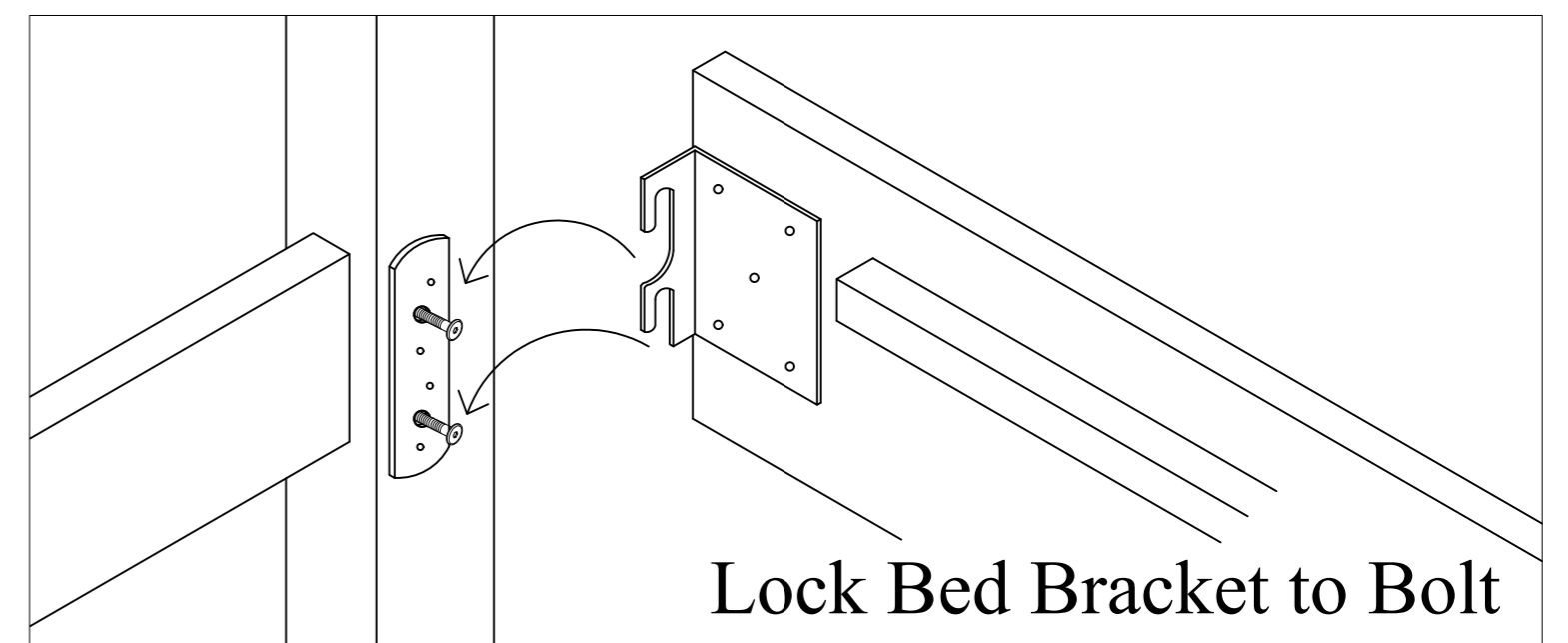
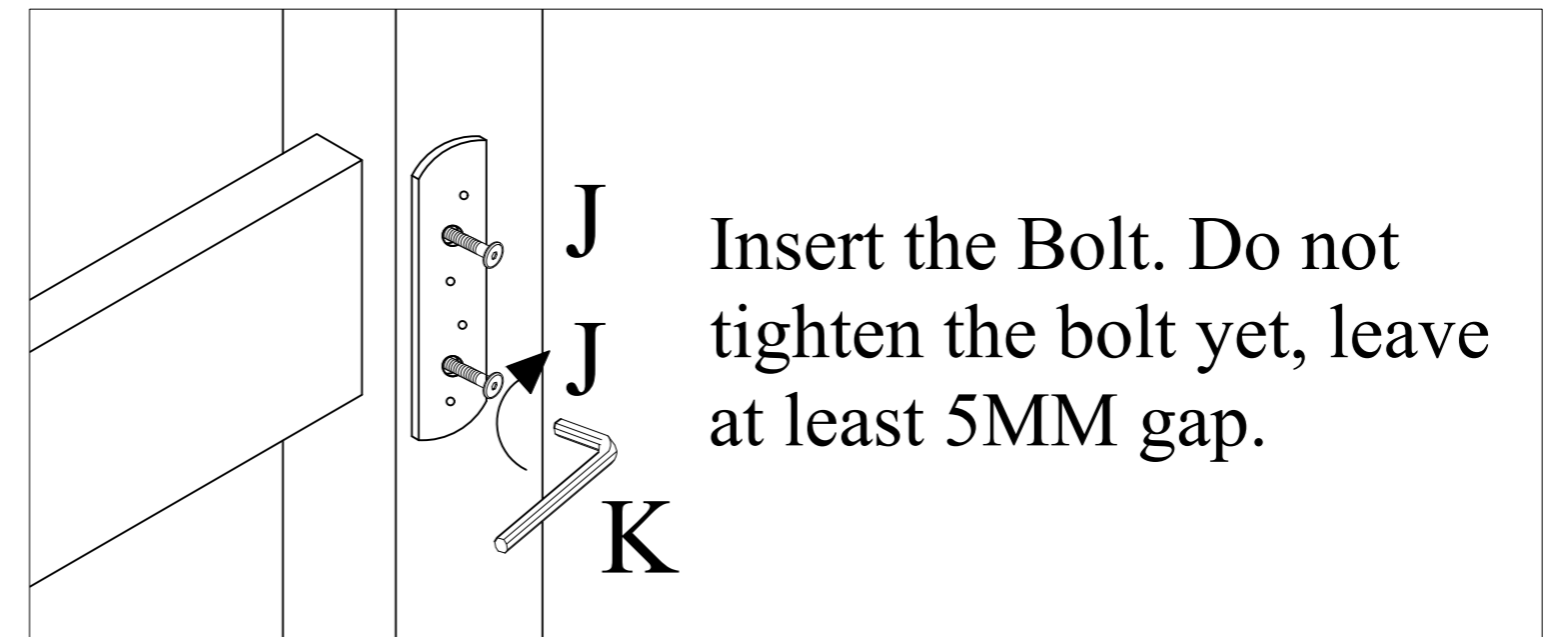
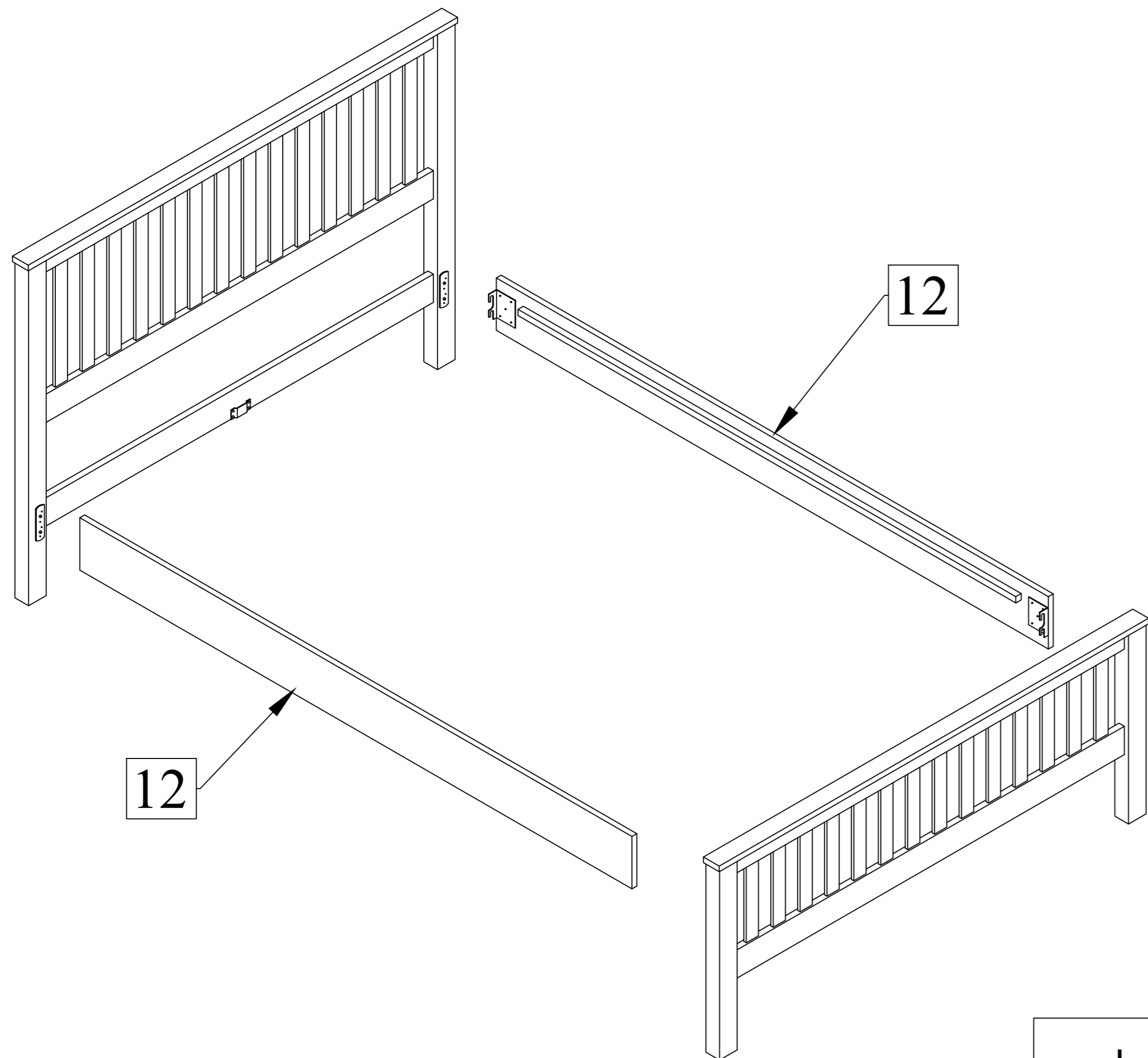

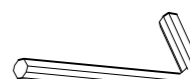
J	Bolt		8PCS
K	Allen Key M5		1PC

Step 5 : Attach the Center Support Rail (13)(14) to the bed.

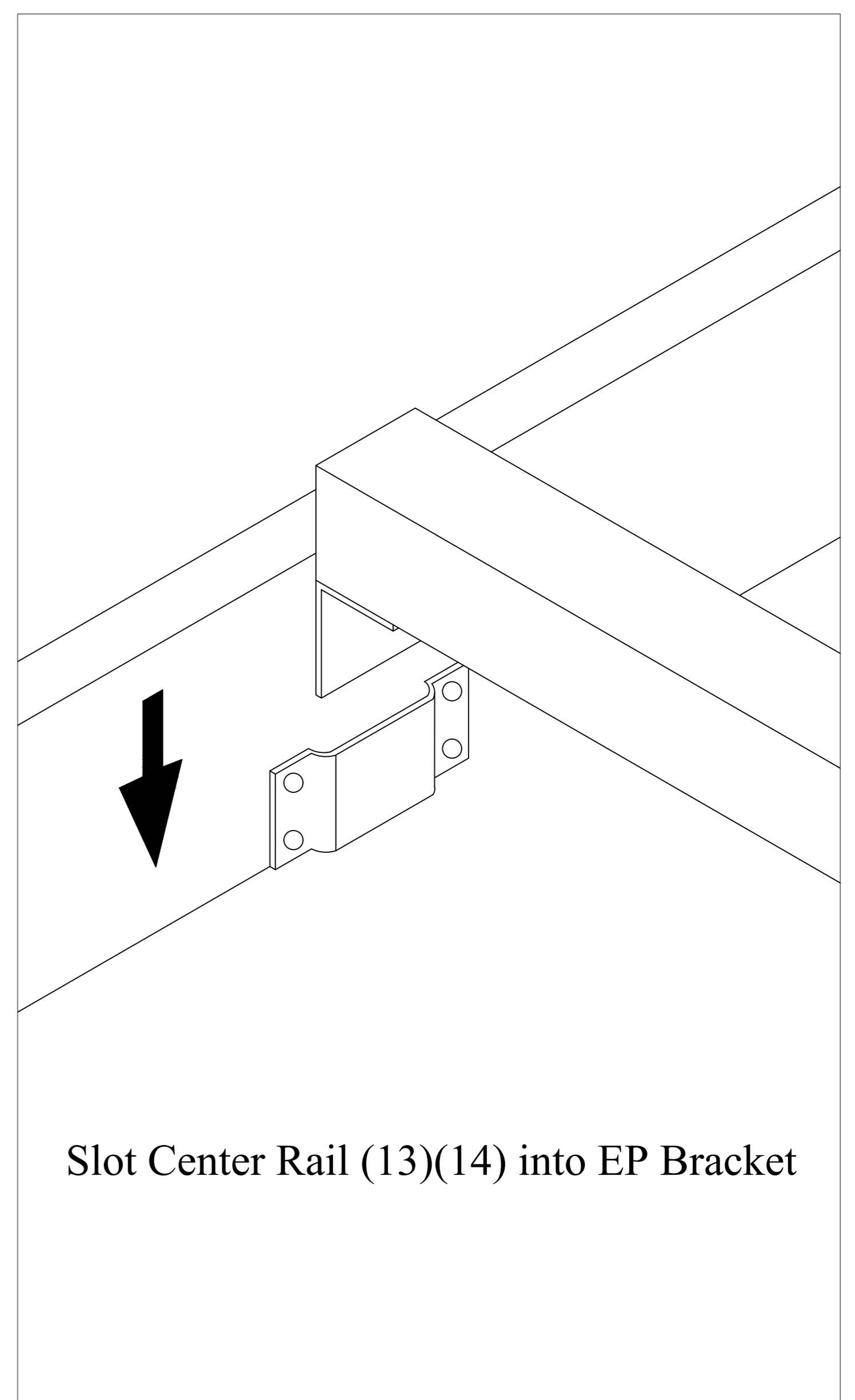
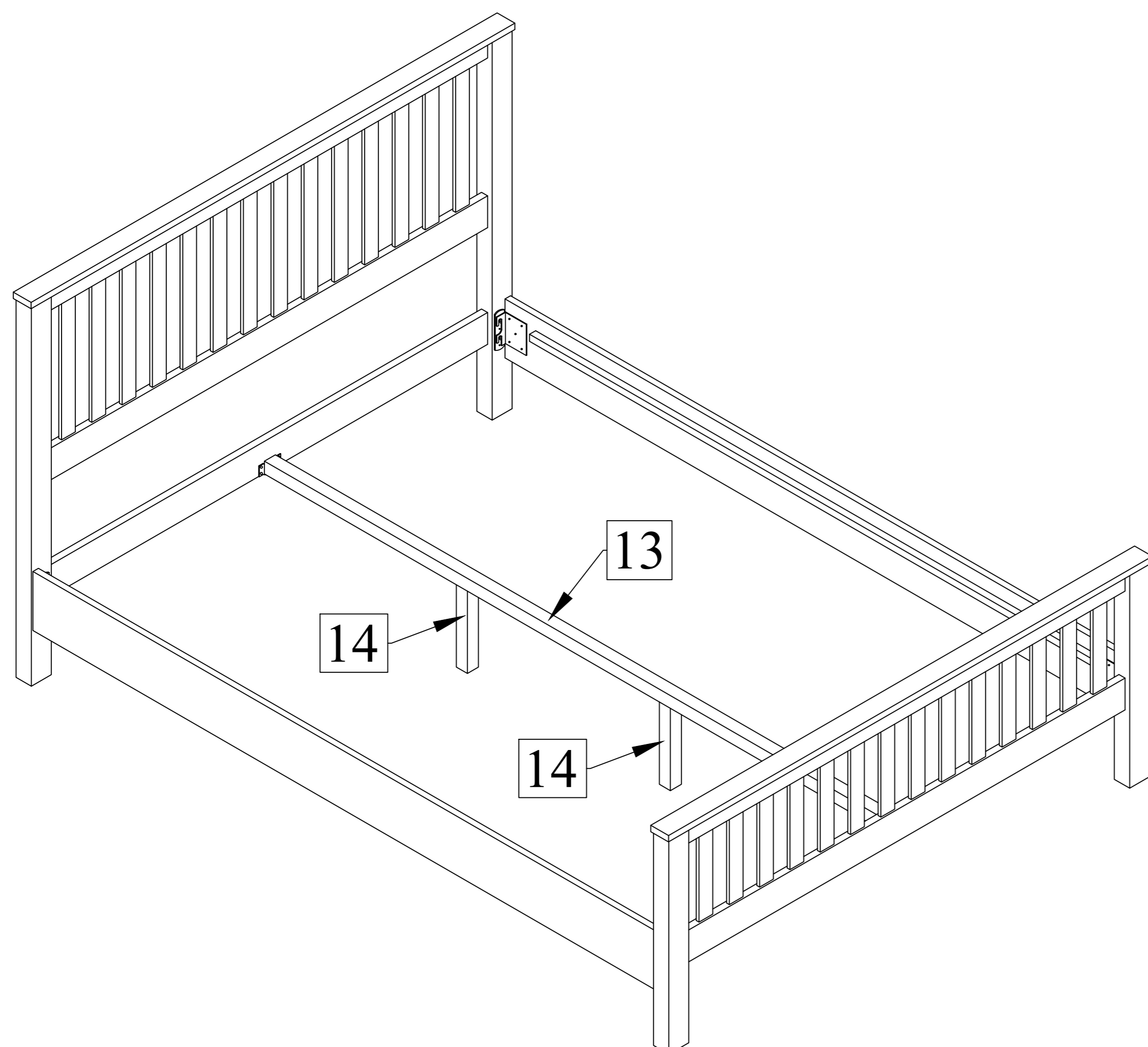

ASSEMBLY INSTRUCTIONS

Item No : WF294587AAG

Description : QUEEN BED

Thank you for purchasing this quality product. Be sure to check all packing material carefully for small part that may have come loose inside carton during shipment.

Step 6 : Attach Bed Slats (15) to the bed using Screw M4 x 32MM (L).

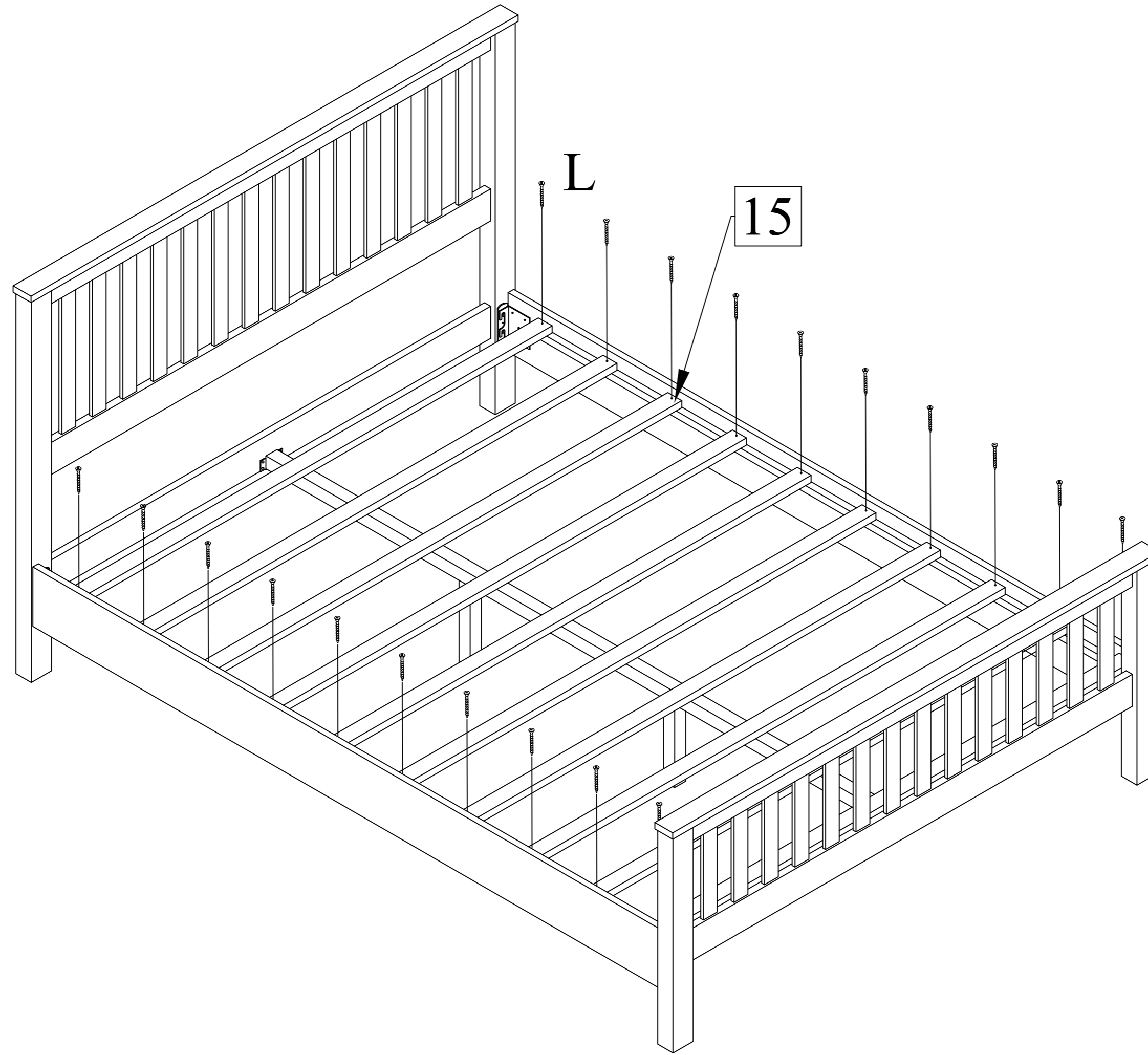

L

Screw M4 x 32MM

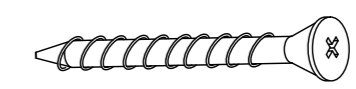

20PCS

Completed assembly.

