

Bookcase

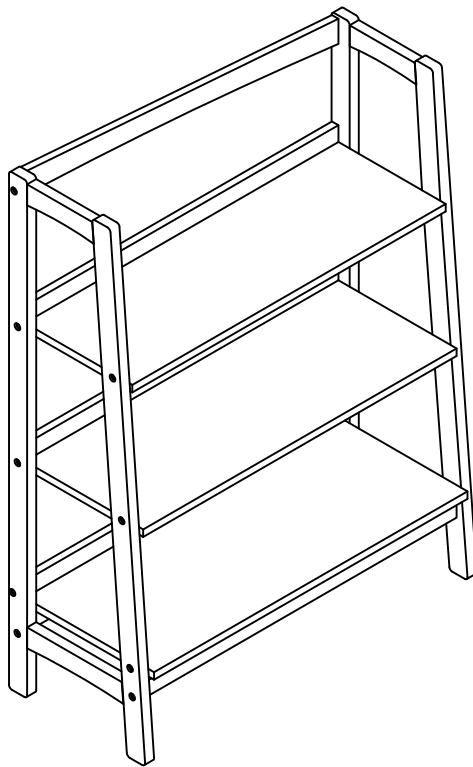

Should you experience any damaged, defective, or missing parts, or need help with assembly, please call us directly before contacting the retailer.

Care and Maintenance Instructions

Keeping Your Furniture Beautiful

Quality furniture is a significant investment expected to last for generations. To maintain its beauty and help it last, furniture needs the right care. No finish is totally indestructible. But with regular care, the finish will last much longer, providing years of enjoyment to you.

Tips to Protect and Care for Your Furniture

1. Avoid placing your furniture in direct sunlight, as sunlight causes fading.
2. Avoid extreme changes in temperature by arranging furniture away from radiators, heat and air vents and air conditioning units.
3. Avoid placing plastic or rubber materials (lamp bases, notebooks, placemats, etc.) on your furniture, as certain plastics contain ingredients that may damage the finish.
4. Periodically rotate accessories on furniture so they do not sit in the same spot all the time.
5. Use pads, cloth or felt to protect the furniture surface from plastic, rubber, hot dishes, beverages, bookends, flowerpots and vases.
6. Clean up spills immediately. Use a blotting rather than a wiping action. Water left over a long period of time will cause white spots in the finish. Alcohol, perfume, after-shave and medications can cause severe finish damage.
7. Use a protective pad when writing on the furniture surface.
8. Lift and place objects rather than dragging them across the furniture surface.
9. Avoid placing furniture directly under windows.

Wood Furniture Care: We recommend dusting frequently with a clean, soft, dry, lint-free cloth. Clean the surface by rubbing in the direction of the grain. We recommend polishing your furniture approximately every six months, using a clean, soft, lint-free cloth and rubbing the polish in the direction of the grain. Guardsman furniture polish or any furniture polish that doesn't contain silicone is recommended.

Leather Furniture Care: Wipe spills immediately with clean cloth or sponge. For spots or stains and daily cleaning, clean with mild non-detergent soap. Rinse well, gently wipe off, and allow to air dry. Cleaning Butter, Oil or Grease from Leather: Wipe leather with a clean cloth, and leave alone. The oil will be absorbed by the leather. DO NOT APPLY WATER. Also, do not use saddle soap, cleaning solvents, furniture polish, oils, varnish, abrasive cleaners, ammonia or any other type of chemical solution.

Granite Furniture Care: Our granite is not sealed, so you may want to apply an over-the-counter sealant, which will provide a small amount of surface protection, but we still recommend cleaning spills promptly. Use a slightly damp cloth to clean as needed. Wipe dry. We also do not recommend using abrasive cleaners, chemical solvents, strong detergents, cleaners with bleach, and furniture polish. Be sure to use trivets, coasters, placemats, and adhesive felt pads to help prevent scratches.

Wicker Furniture Care: Regular cleaning is recommended for wicker, as it generally cannot endure harsh or abrasive treatments. This also minimizes mildew buildup. To remove dirt and debris, vacuum with a dust-brush attachment or use a dry paintbrush. Clean with a mild soap solution. Scrub, and rinse. Avoid using too much water, which can weaken the fibers. Avoid sitting on the wicker when still damp, which can cause wicker to sag.

Metal Furniture Care: Because most metals, except aluminum, are subject to rust, metal furniture is usually finished with layers of clear varnish, paint, or a durable powder coating. Use a mild soap solution, and scrub, rinse, and dry. After cleaning, apply a coat of quality liquid or paste auto wax with a lint-free cloth if recommended by the furniture's manufacturer. Use a silicone spray to lubricate swivels and glides on chairs

Butcher Block Care: For best results, clean finished butcher block surfaces with soapy water or commonly available kitchen counter top cleaners. Do not use abrasives or powder cleansers. Do not allow moisture stand on the surface for prolonged periods of time. To sanitize, rinse the butcher block with white vinegar by using a vinegar-water solution in a spray bottle, spritz the butcher block all over. Let sit for a while. While that sits, make a lemon salt mixture by pouring about 1/4 cup salt into a bowl, and stir in enough lemon juice to make a paste, adjust the consistency as you go, to make a workable paste. The final step, using a scrub brush, thoroughly scrub your butcher block with the lemon-salt paste. If the paste gets too dry, sprinkle on a little more lemon juice. Rinse well, and squeegee off as much water as you can, and then let it dry overnight. Make sure to seal it before you get it dirty

again. Pour out a small amount of oil, and rub it into the wood using a cloth or paper towel. As the oil soaks in, add more and continue rubbing and polishing with the grain until the oil is absorbed. The first time you seal your butcher block, it may take several applications before it stops "drinking" oil, but in later cleanings you'll just need to refresh it. Keep adding oil until no more soaks in, remove any excess with a cloth.



Outdoor Cushion Care: Please note our cushions are made from a polyester foam, and the covers are made from a moisture resistant polyester blend. This does not mean they are waterproof! Cushions should be stored and covered when not in use to protect them from rain, sunlight, and other staining agents. We do not recommend leaving cushions out in inclement weather, and if cushions become wet, please dry them immediately by removing the cushion from the cover so they can dry separately. Wring out any excess moisture before drying. Air dry only!

Outdoor Furniture Storage: We highly recommend storing any outdoor furniture during the winter and/or rainy seasons. Before storing your furniture, please ensure all moisture collected in the frame tubes has been drained out and dried. When outdoor furniture is not in use, we recommend covering all the furniture to protect it against the elements.

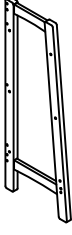
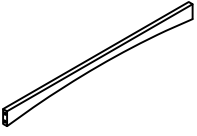
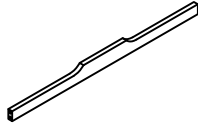
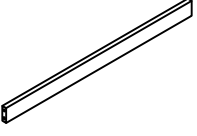
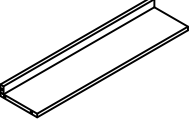
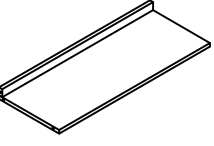
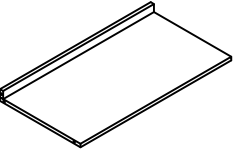
PART LIST

				
Left Side Frame 1 PC	Right Side Frame 1 PC	Back Top Rail 1 PC	Front Bottom Rail 1 PC	Back Bottom Rail 1 PC
				
Top Shelf 1 PC	Middle Shelf 1 PC	Bottom Shelf 1 PC		

HARDWARE LIST

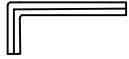
			
#1 Safety Strap Kit 1 PC	#2 Wood Dowel 13 PCS (Extra 1) Ø8x40	#3 Allen Bolt 19 PCS (Extra 1) M6x35	#4 Allen Wrench 1 PC M4

ADDITIONAL TOOLS (Not Provided)

Note: It is not recommended to use power tools during assembly.



Phillips Head Screwdriver

Step 1. Attach back top rail (part C), front bottom rail (part D) and back bottom rail (part E) to right side frame (part B) by using wood dowels (part #2), allen bolts (part #3) and allen wrench (part #4).

Note: Do not fully tighten bolts until unit is fully assembled.

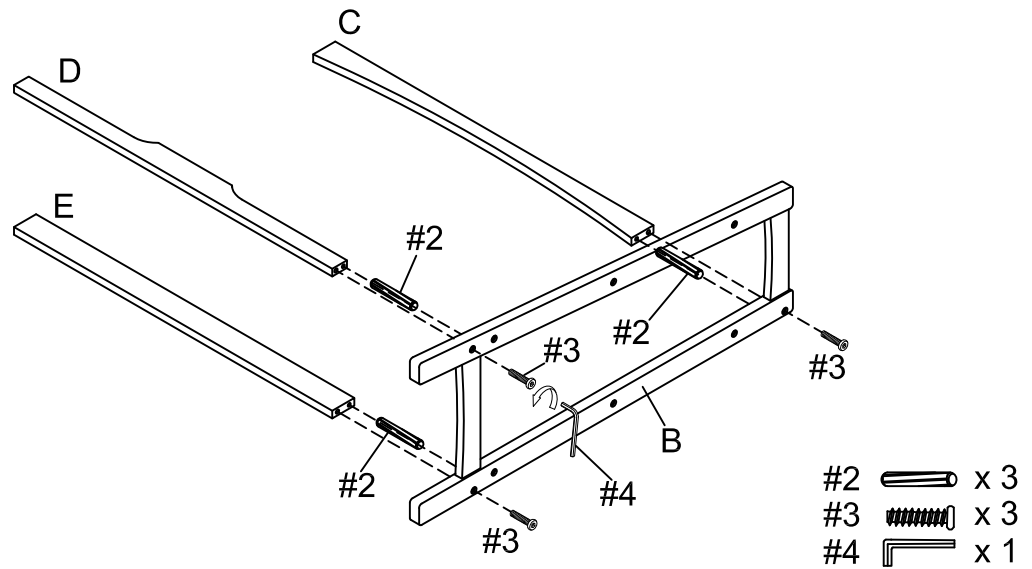



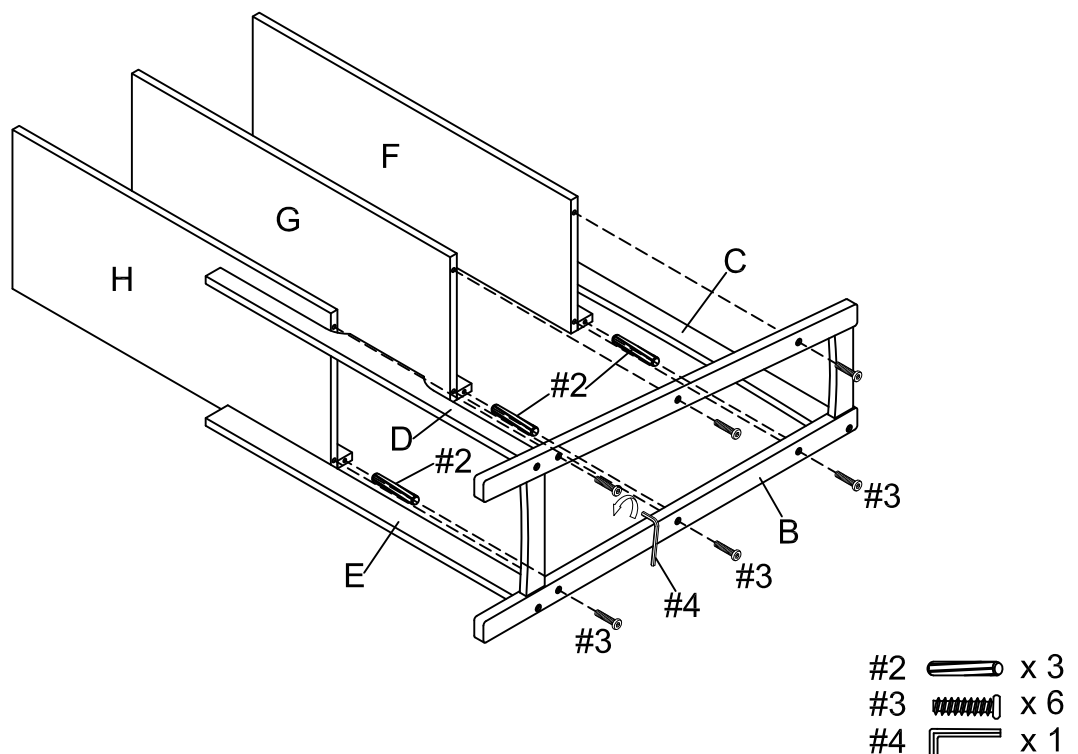

Step 2. Attach top shelf (part F), middle shelf (part G) and bottom shelf (part H) to right side frame (part B) by using wood dowels (part #2), allen bolts (part #3) and allen wrench (part #4).

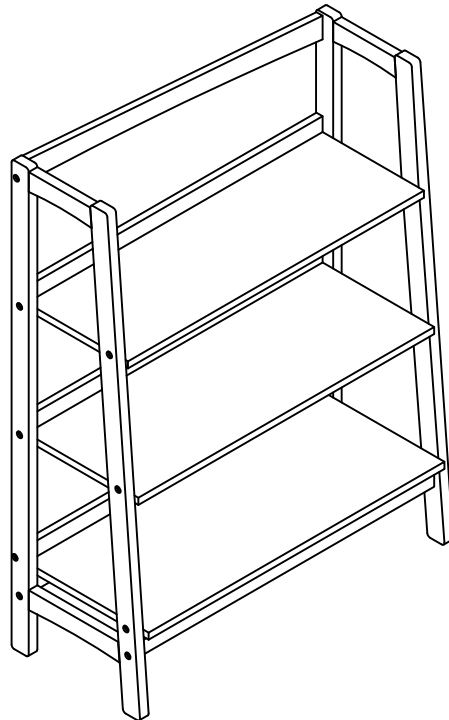
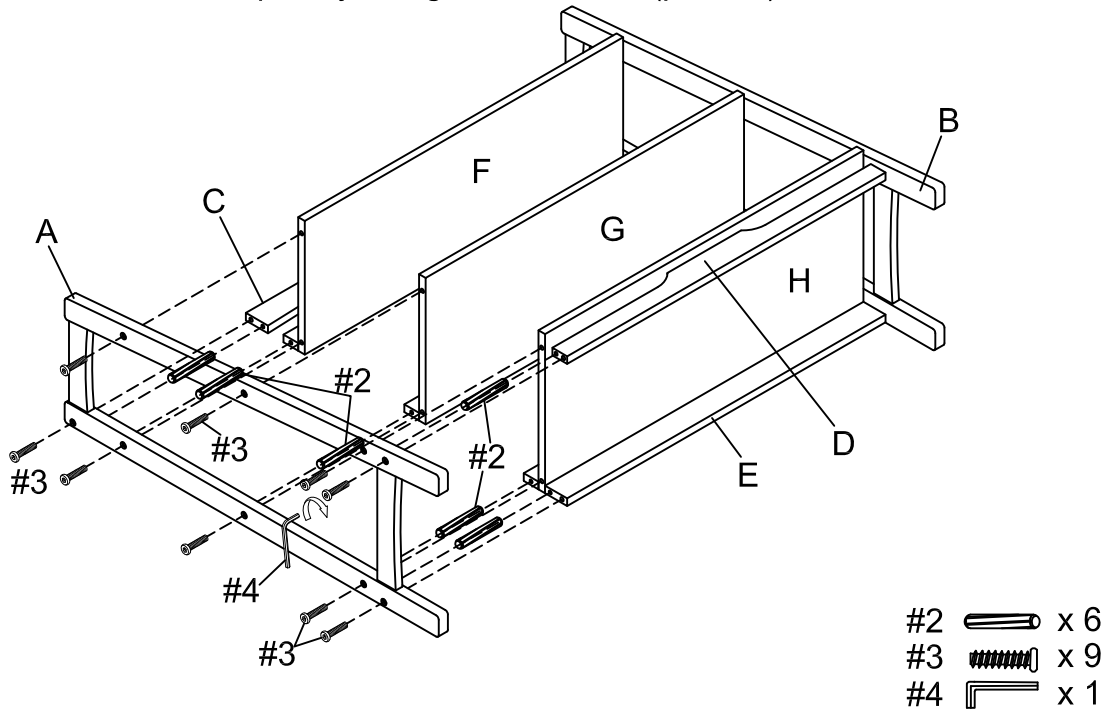

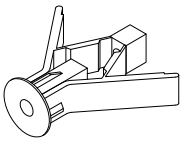
Step 3. Attach left side frame (part A) to back top rail (part C), top shelf (part F), middle shelf (part G), bottom shelf (part H), front bottom rail (part D) and back bottom rail (part E) by using wood dowels (part #2), allen bolts (part #3) and allen wrench (part #4). Tighten all the bolts completely using allen wrench (part# 4).

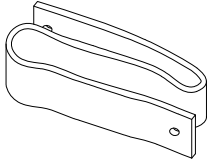

	<p>Safety Strap Kit 1 PC</p>	<p>A</p> 	<p>B</p> 	<p>C</p> 	<p>D</p> 	<p>E</p> 
		<p>Wall Anchor A x 1 PC</p>	<p>Washer B x 2 PCS</p>	<p>D8*3/4" Short Screw C x 1 PC</p>	<p>D8*1-1/2" Long Screw D x 1 PC</p>	<p>Safety Wall Strap E x 1 PC</p>

SAFETY STRAP WALL ASSEMBLY INSTRUCTION

1) Insert short screw (part #C) through washer (part #B) and safety wall strap (part #E) and screw it into the top center of top shelf (part F).

2) Drill a 11/32" hole where you want to secure your unit. The hole should be at the same height as the hole in the top center of top shelf (part F). Tap wall anchor (part #A) into the hole.

3) Insert long screw (part #D) through washer (part #B) and wall safety strap (part #E) into the wall anchor (part #A).

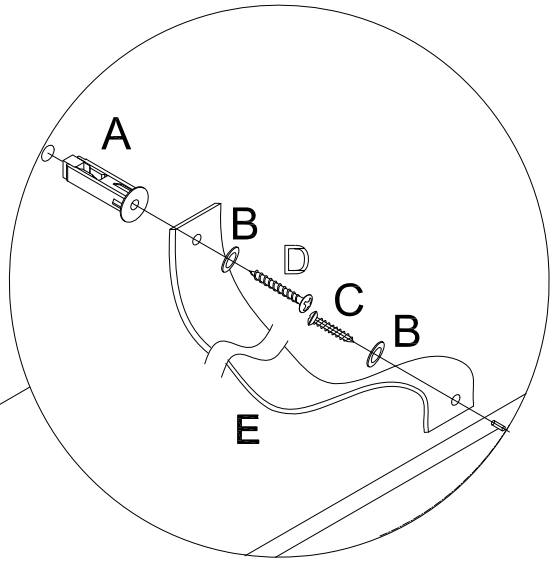

Wall

