

Optima® EAF-350

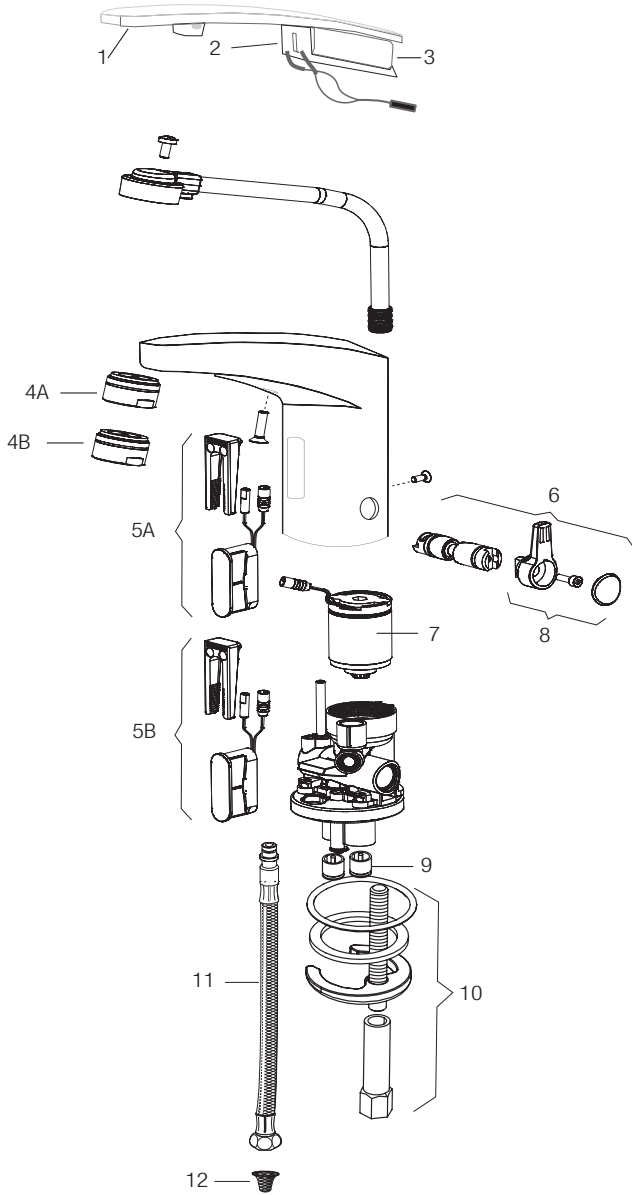

PARTS LIST—EAF-350 FAUCETS

Item No.	Code No.	Part No.	Description
1.	0335040	EAF-60	Cover
2.	0335043	EAF-61	Cover Clip – Battery Support
3.	3324166	EFX-1015-A	Battery Replacement Kit (with 2.5 mm hex key)
4A.	0335021	EAF-22	1.5 gpm (5.6 Lpm) AER Spray Head
4B.	0335036	EAF-63	0.5 gpm (1.9 Lpm) AER Spray Head
5A.	3335116	EAF-1021-A	Electronic Sensor (15 Second Shut-off) with Fixing Clip Kit (0.5 gpm only)
5B.	3335113	EAF-1018-A	Electronic Sensor (7 Second Shut-off) with Fixing Clip Kit (1.5 gpm only)
6.	3335114	EAF-1019-A	Mixer Handle Assembly and Cartridge Kit
7.	0335001	EAF-2	Solenoid Valve Cartridge (IQ Faucet)
8.	0335115	EAF-1020-A	Handle Repair Kit
9.	0335006	EAF-8	Back Check (2 required for ISM models)
10.	0335000	EAF-1	Faucet Mounting Kit
11.	3335023	EAF-1008	13" (330 mm) Flexible Supply Hose (2 required for ISM models)
12.	0335007	EAF-9	Filter (2 required for ISM models)

IR-Click Settings

Function	Press Button	LED Signal
Temporary OFF (2 min)	1. 1 time for 2 seconds 2. 2 times (double push)	1. LED Green (1) 2. LED Red pulsating flashes
reset:	1 time or will reset automatically after 2 mins	
Continuous Run 2 minute default setup (adjustable from 1-20 mins)	1. 1 time for 2 seconds 2. 1 time for 3-5 seconds	1. LED Green (1) 2. Water flows after releasing
reset:	1 time or will reset automatically after 2 mins	
Sensor Range Adjustment	1. 1 time for 2 seconds 2. 2 times (double push) 3. 1 time for 5 seconds then hold till requested range is reached 4. Release	1. LED Green (1) 2. LED Red blinks 3. LED Red (1-8) 4. LED Green (1)

Optima® EAF-350

TROUBLESHOOTING GUIDE

1. Faucet DOES NOT function.

- A. "Permanent Off" activated. Press button on faucet throat one time.

2. Faucet delivers water in an uncontrolled manner.

- A. Faucet is not working properly. Contact Sloan Technical Support.

3. Faucet DOES NOT deliver any water when Sensor is activated.

INDICATOR: Solenoid valve produces an audible "CLICK."

- A. Water supply stop(s) closed. Open water supply stop(s).
 B. Water supply stop strainer(s) clogged. Remove, clean, and reinstall water supply stop strainer(s). Replace strainer(s) if required.

INDICATOR: Solenoid valve DOES NOT produce an audible "CLICK."

- A. Battery low (battery powered models). Replace battery (refer to Battery Replacement on page 184).

4. After removing label water does not flow.

Use this installation guide as a target by placing it in front of the sensor (approx. 1-1/2" away) until water begins flowing, then remove installation instruction from sensor. Water will stop flowing, wait 10 seconds before using faucet.

5. Faucet delivers only a slow flow or dribble when sensor is activated.

- A. Water supply stop(s) are partially closed. Completely open water supply stop(s).
 B. Water supply stop strainer(s) clogged. Remove, clean, and reinstall water supply stop strainer(s). Replace strainer(s) if required.
 C. Aerator is clogged. Remove, clean, and reinstall Aerator. Replace Aerator if required.
 D. Faucet is not working properly. Contact Sloan Technical Support.

6. Faucet DOES NOT stop delivering water or continues to drip after user is no longer detected.

- A. Faucet is not working properly. Contact Sloan Technical Support.

7. LED indicator blinks when faucet is in use.

- A. Battery low (battery powered models). Replace battery.

8. The water temperature is too hot or too cold on a faucet connected to hot and cold supply lines.

- A. Supply stops are not adjusted properly. Adjust supply stops.
 B. For models with integral mixing valve – Mixing valve is set improperly for the water temperature desired. Rotate mixing valve handle clockwise to decrease water temperature or counterclockwise to increase water temperature.

OPERATION

As the user's hands enter the beam's effective range, the beam is reflected back into the sensor receiver and activates the solenoid valve allowing water to flow from the faucet. Water will flow until the hands are removed or until the faucet reaches its automatic time out limit setting.

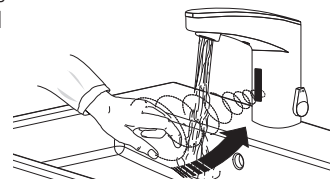

CARE AND CLEANING

DO NOT use abrasive or chemical cleaners (including chlorine bleach) to clean faucet that may dull the luster and attack the chrome or special decorative finishes. Use **ONLY** mild soap and water, then wipe dry with clean cloth or towel.

While cleaning the bathroom tile, protect the faucet from any splattering of cleaner. Acids and cleaning fluids will discolor or remove chrome plating.



When assistance is required, please contact Sloan Technical Support at: 1-888-SLOAN-14 (1-888-756-2614).