

ASSEMBLY INSTRUCTIONS

TOOLS REQUIRED



Allen Wrench

(Included)



Phillips
Screwdriver

(Not Included)

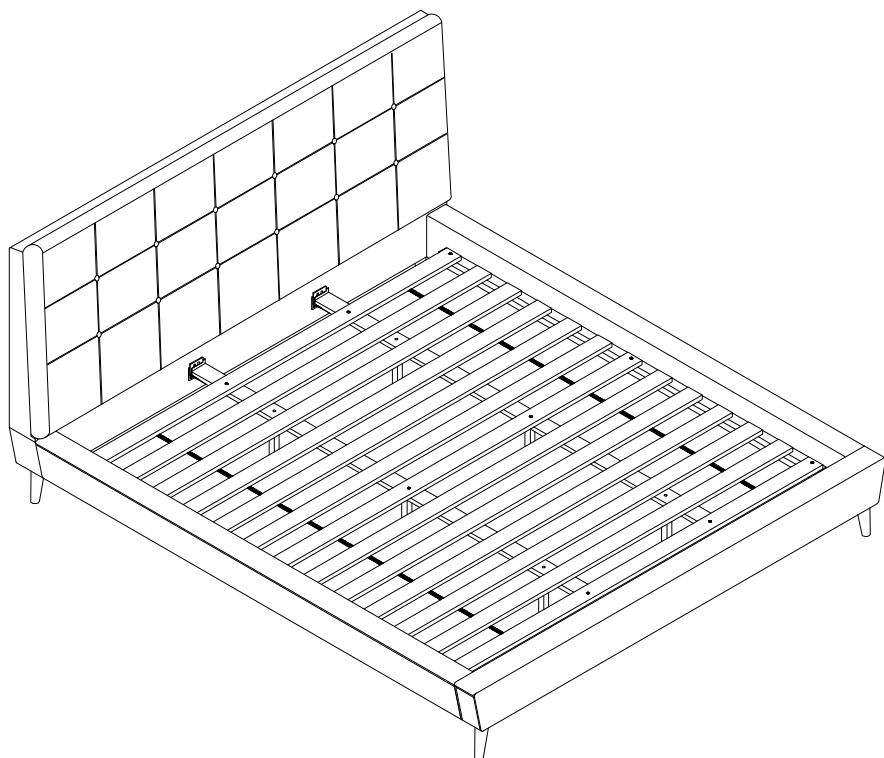

2 - People
Recommended

ASSEMBLY RATING



EASY —————> DIFFICULT

The Assembly Rating is a 5-point system showing the level of effort needed to assemble a specific product.



CHECK BEFORE STARTING

Are you missing anything?

Double-check all parts, hardware and accessories listed are all accounted for.

Check out our Quick Tips!

We recommend reviewing the pre-assembly handouts. Even experts need a refresher now and then!

Should we send any replacements?

Are there any irregularities or flaws in the parts? We can send replacements!

Prep Time!

Please review the assembly instructions and all diagrams prior to assembling.

PRE ASSEMBLY INTRODUCTION

We understand building ready-to-assemble furniture can be a challenging experience for some. To help avoid confusion, we have provided some helpful tips that may speed up the process.

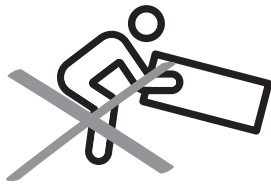

Teamwork

ALWAYS have at least two people to help with transporting and assembling the product to avoid potential injury and/or damage.



Suitable Location

Assembling near the area of the intended location is highly recommended.



Sufficient Space

Make sure you have enough space to move around during the assembly.



Avoid Scratches

Use cardboard, blankets or a carpeted area while assembling furniture to prevent to prevent scratches and damages.



Flat Surface

Make sure the furniture rests on a flat and level surface with each leg evenly touching the floor.

ASSEMBLY AND CARE ADVICE



FAILURE TO FOLLOW THE GUIDELINES BELOW MAY RESULT IN INJURY AND/OR PROPERTY DAMAGE.



Position each part correctly and insert screws or bolts into their respective holes.



Turn clockwise to tighten and only tighten when step is completed or when instructed to do so.



Use the appropriate hand tools or power tools for assembly. Select steps, such as tightening screws and/or bolts, may require hand tools to avoid causing damage during assembly.



Save the instructions and store any supplied tools for later maintenance.



After two weeks, check and tighten any loose hardware and repeat again every six months thereafter.

IT IS THE USER'S RESPONSIBILITY TO MAINTAIN THE FURNITURE. THE HARDWARE MAY LOOSEN OVER TIME AND MAY CAUSE THE FURNITURE TO BE WOBBLY AND UNABLE TO SUPPORT ITS INTENDED WEIGHT CAPACITY. THIS MAY LEAD TO COLLAPSE AND MAY CAUSE SERIOUS INJURY.

BED

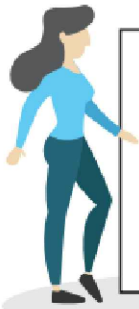

- Please keep instructions for future reference.
- Check the quantity and irregularity of parts and hardware before you start.

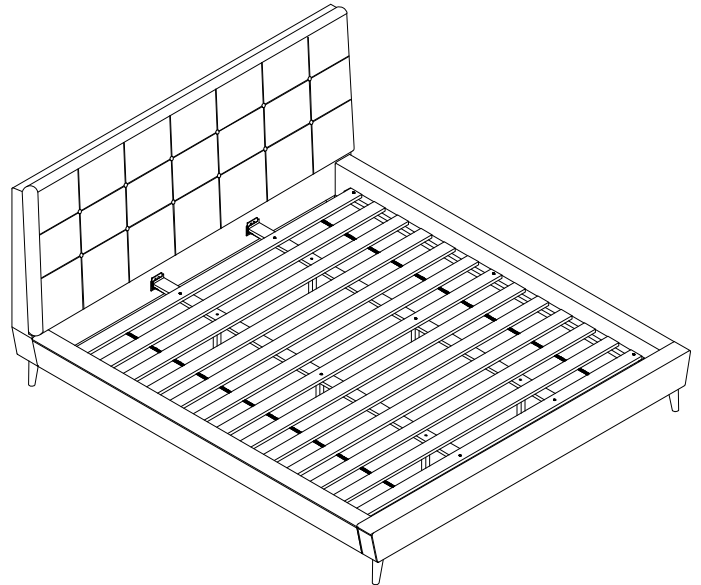

PARTS

#1 1pc

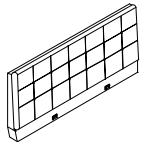

Headboard

#2 4pcs



Leg(Iron plate)

#3 1pc

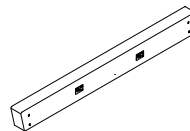

Footboard

#4 2pcs

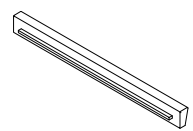

Siderail

#5 6pcs



Support Leg
(190x35x35mm)

#6 2 pcs

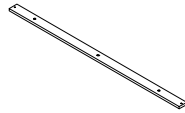

Center rail

#7 1 set

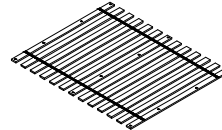

Slat (13pcs)

HARDWARE

#A 12pcs



Bolts
Ø5/16" x 1"

#B 20pcs



Lock Washer
Ø5/16"

#C 20pcs



Flat Washer
Ø5/16"

#D 2pcs



Allen key M4

#E 8pcs

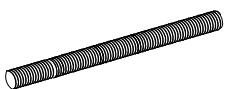

Bolts
Ø5/16" x 3-1/2"

#F 8pcs



Hex nut
5/16"x12mm

#G 1pc



Flat Washer
Ø5/16"

#H 8pcs



Screw
#4x20mm









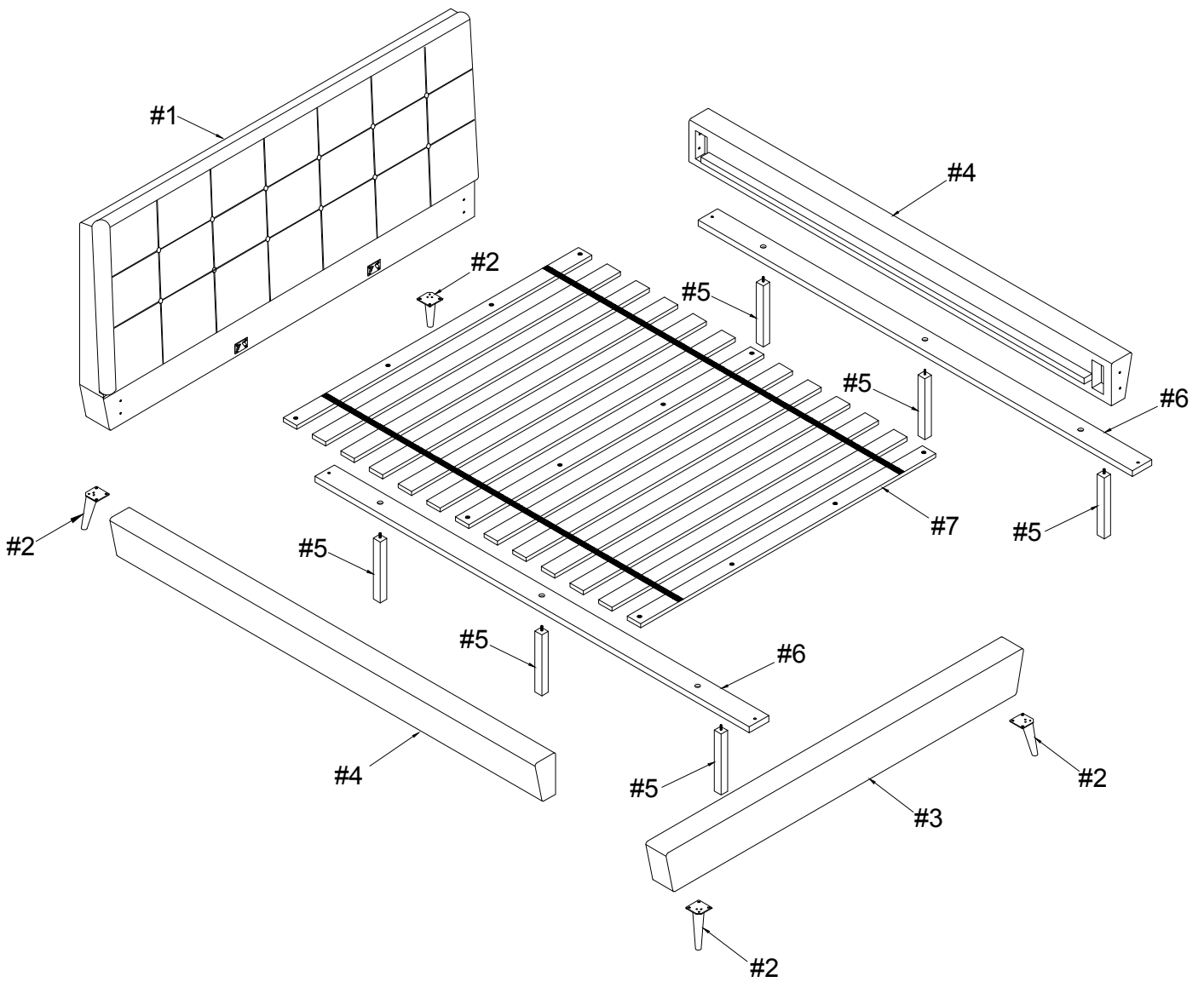

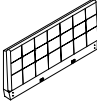



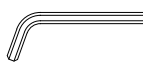

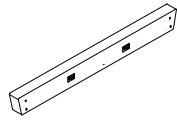



#1 12pcs

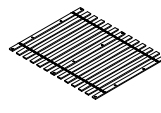

Screw
#4x32mm

Exploded View

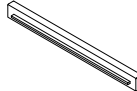

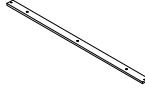
Carton	Design ation	Part		Hardware
	Headboard	#1		 #A x 6pcs  #B x 6pcs  #C x 6pcs  #D x 1pc
	Leg (2pcs)	#2		
	Footboard	#3		 #A x 6pcs  #B x 14pcs  #C x 14pcs  #D x 1pc  #E x 8pcs  #F x 8pcs  #G x 1pc  #H x 8pcs  #I x 12pcs
	Slat	#7		
	Leg (2pcs)	#8		
	Side rail (2pcs)	#4		
	Slat Leg (6pcs) (190x35x35mm)	#5		
	Center rail (2pcs)	#6		

ASSEMBLY INSTRUCTIONS

1

Remove the legs (#2) from the back of the Headboard (#1).

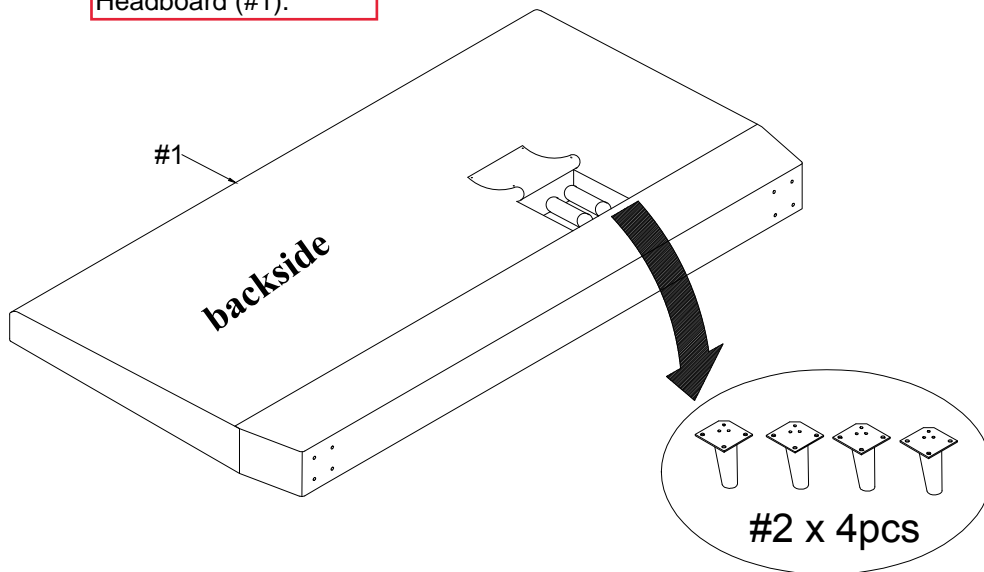

2

Align legs (#2) to the Headboard (#1) then secure by using Bolts (#A) with Washers (#B,C).

- Part #1 x1pc
- Part #2 x2pcs
- Hardware #A x6 pcs
- Hardware #B x6 pcs
- Hardware #C x6 pcs

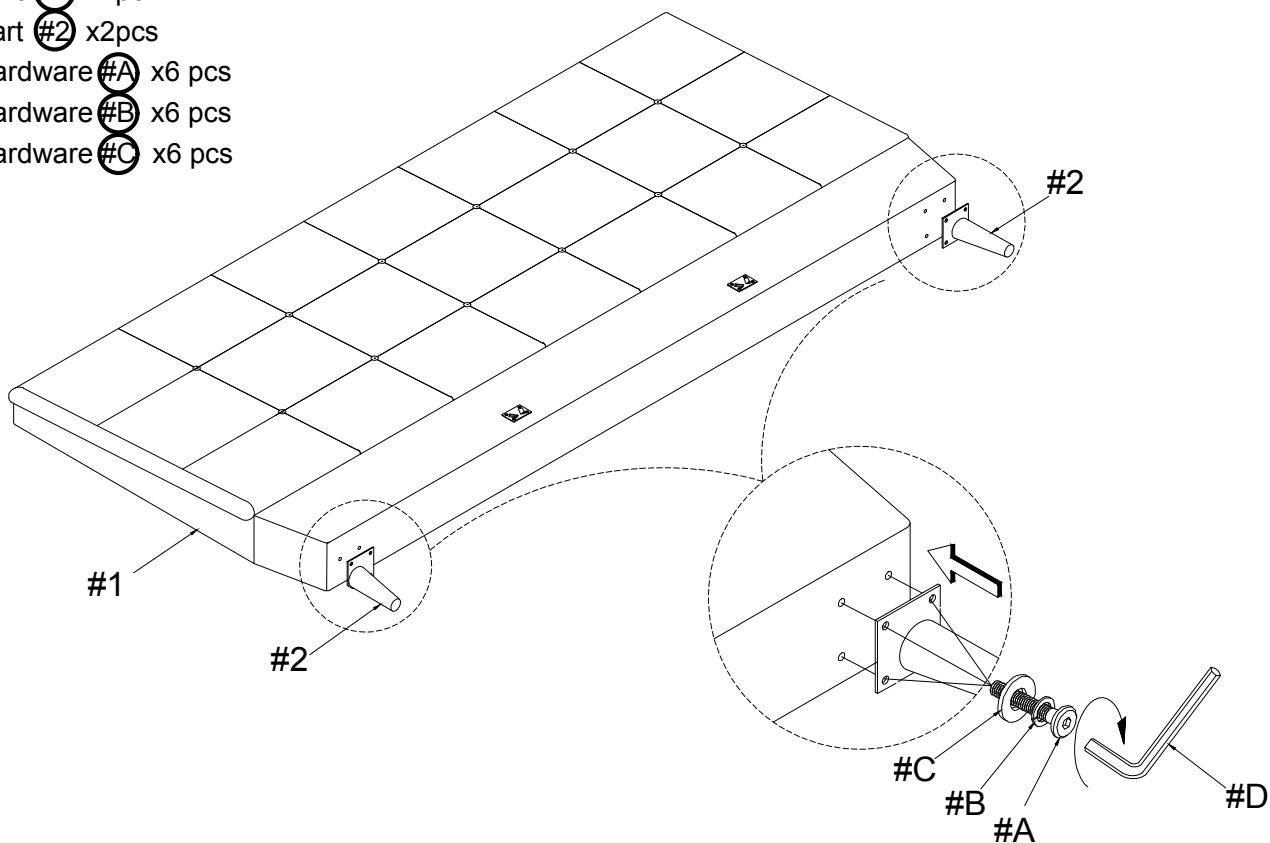

ASSEMBLY INSTRUCTIONS

3

- Part #2 x2pcs
- Part #3 x1pc
- Hardware #A x6 pcs
- Hardware #B x6 pcs
- Hardware #C x6 pcs

Align legs (#2) to the Footboard (#3) then secure by using Bolts (#A) with Washers (#B,C).

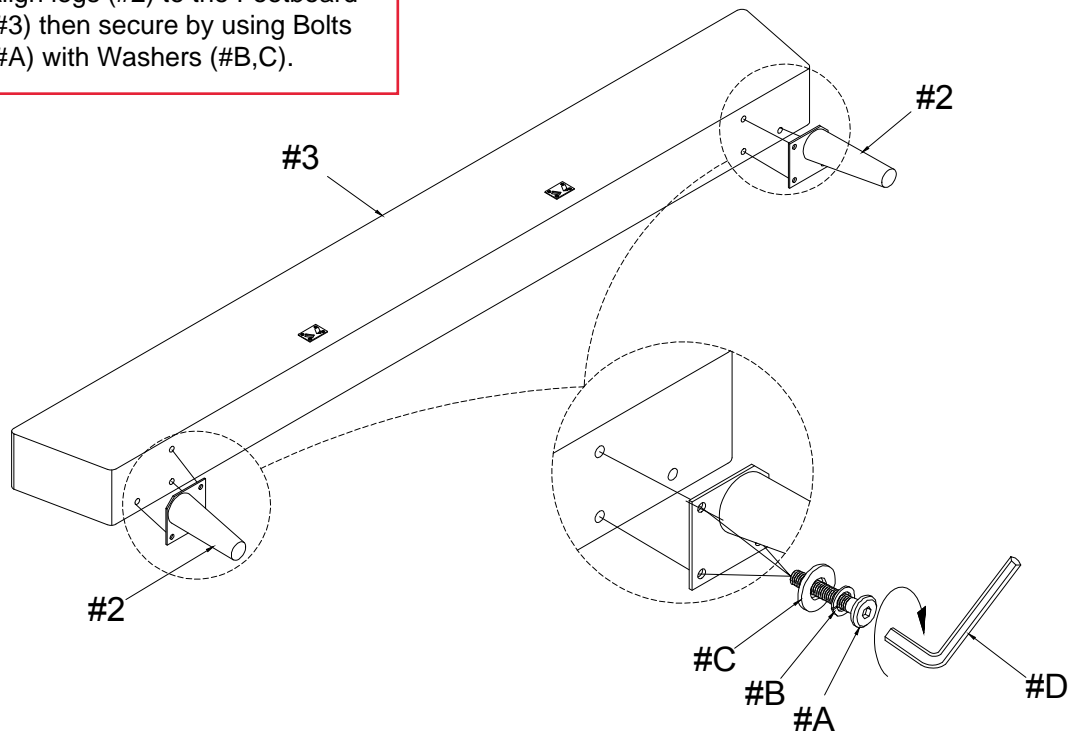

4

- Part #4 x2pcs
- Hardware #B x8 pcs
- Hardware #C x8 pcs
- Hardware #E x8 pcs
- Hardware #F x8 pcs

Attach Bolts (#E) to the Headboard (#1) and Footboard (#3). Then align Side rails (#4) and secure using Washers (#B,C) with Hex Nut (#F).

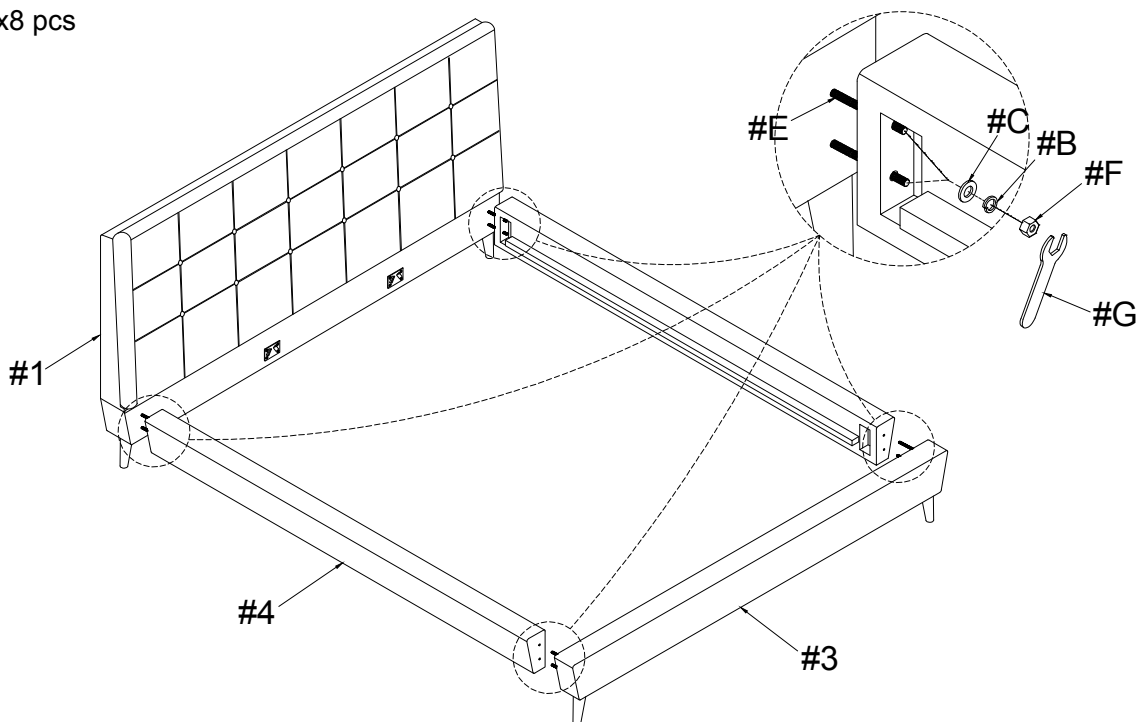

ASSEMBLY INSTRUCTIONS

5

Part #5 x3pcs
Part #6 x1pc

Attach Support legs (#5) to the Center rail (#6).

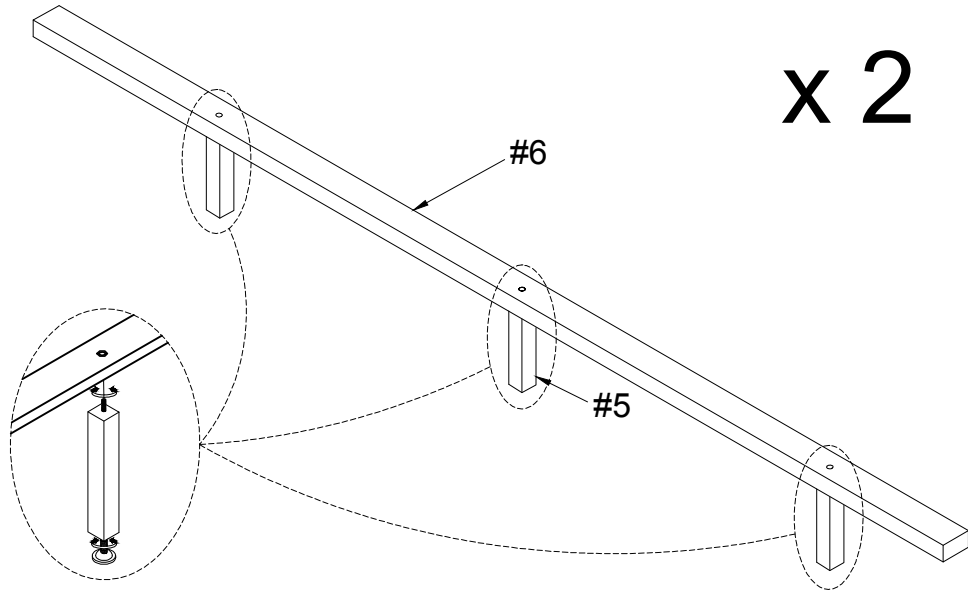

6

Hardware #H x8 pcs

Align Center rails (#6) to the Headboard (#1) and Footboard (#3). Then secure using screws (#H) and lock down into place.

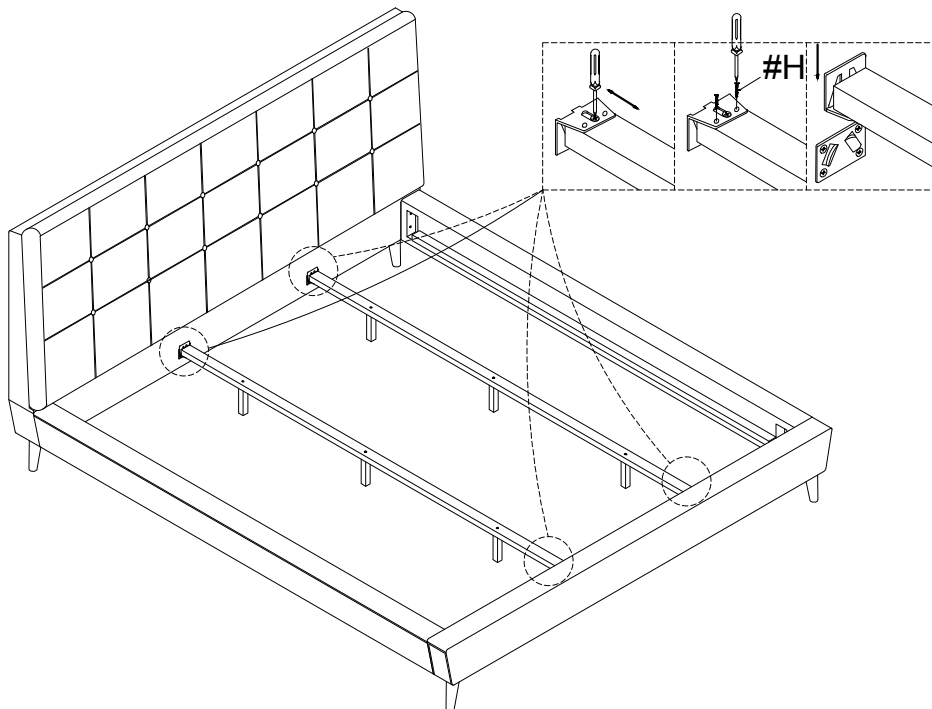

ASSEMBLY INSTRUCTIONS

7

Hardware  x 12 pcs

Align Slats (#7) to the Side rails (#3) then secure by using screws (#1).

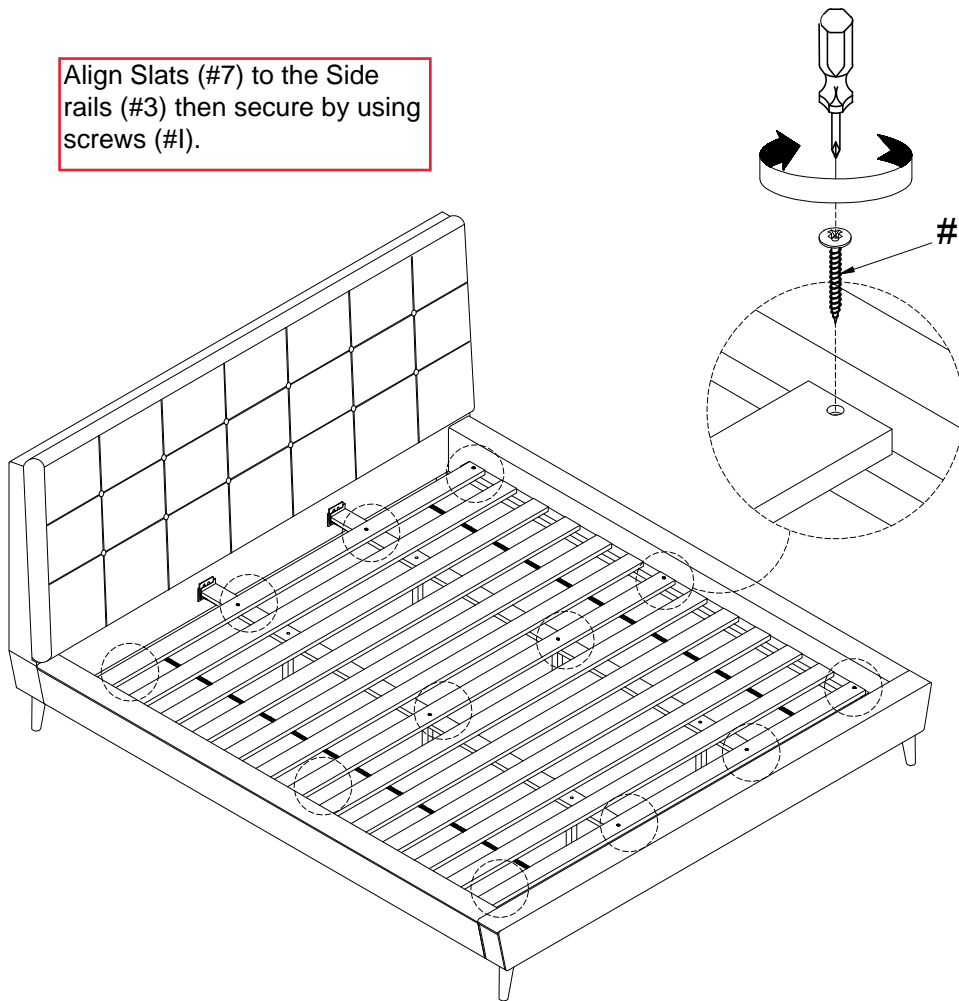

ASSEMBLY COMPLETED



Please ensure the furniture rests on an even and flat surface. If the product wobbles or feels loose, double-check all bolts and/or screws are properly tightened and secured.



Keep this handy!

Please retain this instruction manual and any order-related information for future reference.



Lift, don't drag!

To avoid damage to product please always LIFT the product when transporting or adjusting the placement.