

ASSEMBLY INSTRUCTIONS

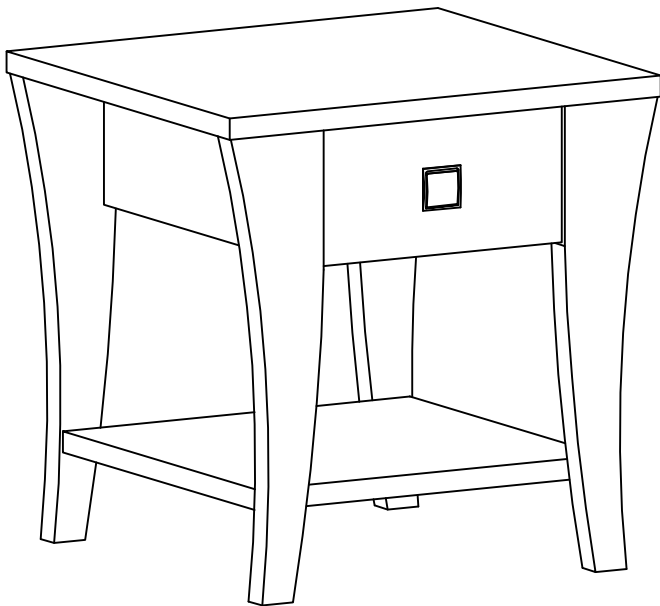

TOOLS REQUIRED



**Philips
Screwdriver**

(Not Included)

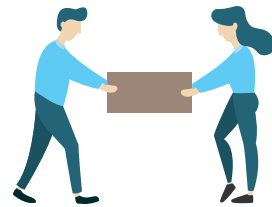

**2 - Persons
Recommended**

ASSEMBLY RATING



EASY → DIFFICULT

The Assembly Rating is a 5-point system showing the level of effort needed to assemble a specific product.



CHECK BEFORE STARTING

Are you missing anything?

Double-check all parts, hardware and accessories listed on Page 6 are accounted for.

Should we send any replacements?

Are there any irregularities or flaws in the parts? We can send replacements!

Check out our Quick Tips!

We recommend reviewing the pre-assembly handouts. Even experts need a refresher now and then!

Prep Time!

Please review the assembly instructions and all diagrams prior to assembling. Arrange parts as recommended on Page 7 and group identical hardware together to make assembling easier.

PRE ASSEMBLY INTRODUCTION

We understand building ready-to-assemble furniture can be a challenging experience for some. To help avoid confusion, we have provided some helpful tips that may speed up the process.

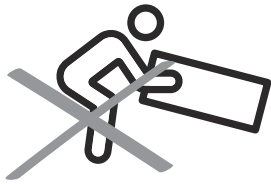

Teamwork

ALWAYS have at least two people to help with transporting and assembling the product to avoid potential injury and/or damage.

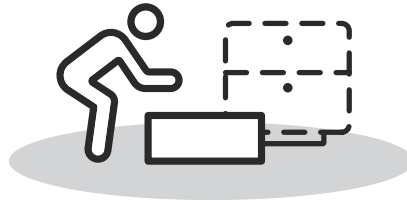
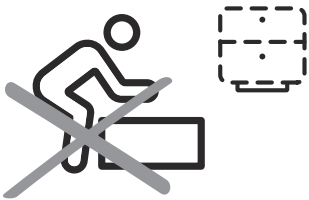

Suitable Location

Assembling near the area of the intended location is highly recommended.



Sufficient Space

Make sure you have enough space to move around during the assembly.

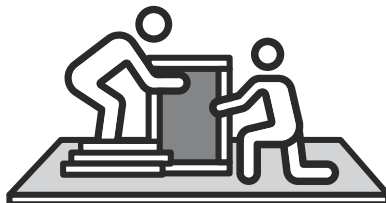

Avoid Scratches

Use cardboard, blankets or a carpeted area while assembling furniture to prevent scratches.

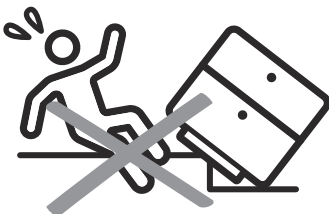

Flat Surface

Make sure the furniture rests on a flat and level surface with each leg evenly touching the floor.

ASSEMBLY AND CARE ADVICE



FAILURE TO FOLLOW THE GUIDELINES BELOW MAY RESULT IN INJURY AND/OR PROPERTY DAMAGE.



Position each part correctly and insert screws or bolts into their respective holes.

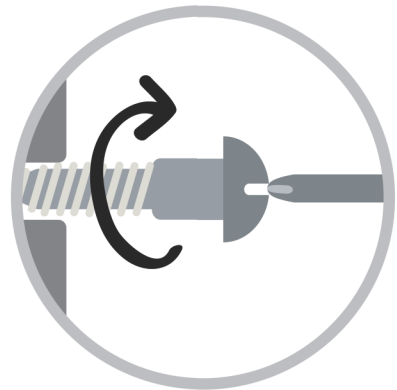

Turn clockwise to tighten and only tighten when step is completed or when instructed to do so.



Use the appropriate hand tools or power tools for assembly. Select steps, such as tightening screws and/or bolts, may require hand tools to avoid causing damage during assembly.



Save the instructions and store any supplied tools for later maintenance.

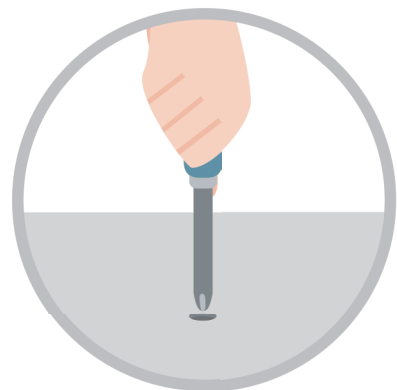

After two weeks, check and tighten any loose hardware and repeat again every six months thereafter.

IT IS THE USER'S RESPONSIBILITY TO MAINTAIN THE FURNITURE. THE HARDWARE MAY LOOSEN OVER TIME AND MAY CAUSE THE FURNITURE TO BE WOBBLY AND UNABLE TO SUPPORT ITS INTENDED WEIGHT CAPACITY. THIS MAY LEAD TO COLLAPSE AND MAY CAUSE SERIOUS INJURY.

CAM LOCK FASTENER ASSEMBLY INSTRUCTIONS

Note :

Every cam lock bolt must have a cam lock connector in order to fasten the parts together.

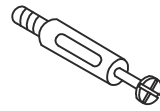

cam bolt



cam lock

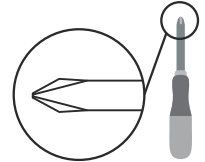

screwdriver

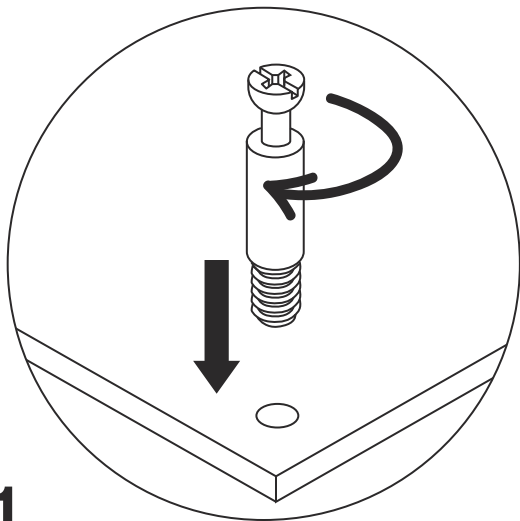

1

Screw the cam bolt into panel.

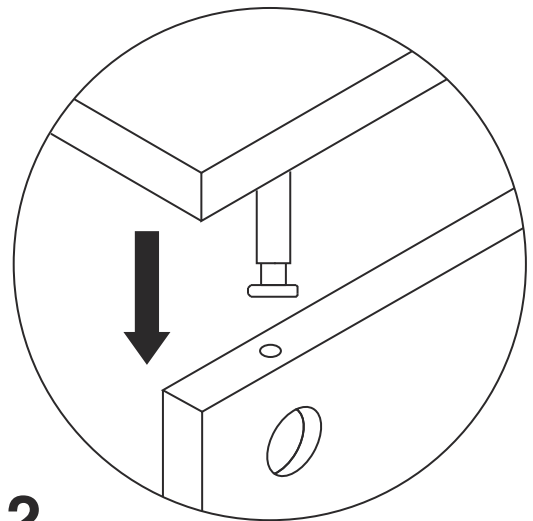

2

Insert the cam bolt into the bolt hole of joint panel.

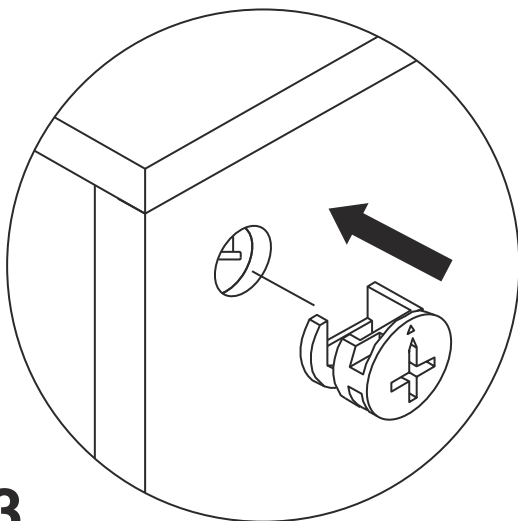

3

Align the cam lock with its side opening (or arrow) pointing to cam bolt.

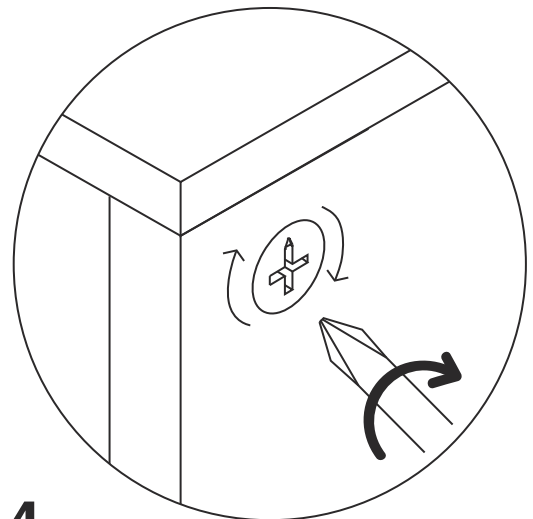

4

Turn the cam lock clockwise gently until it will not turn any more.

END TABLE

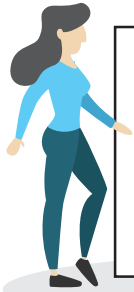

- Please keep instructions for future reference.
- Check the quantity and irregularity of parts and hardware before you start.

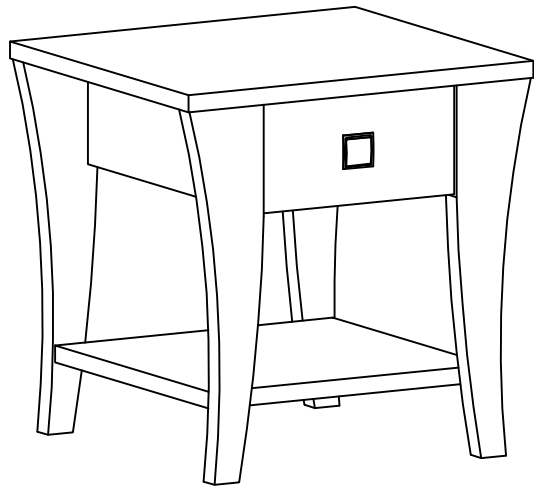

PARTS

#1 1pc

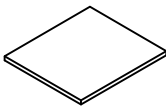
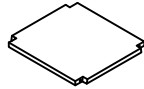

Table Top

#2 1pc



Bottom Panel

#3 1pc

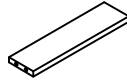

Front Crossbar

#4 1pc

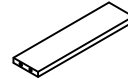

Rear Crossbar

#5 1pc

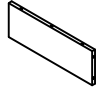

Left Side Panel

#6 1pc



Right Side Panel

#7 1pc

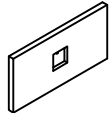

Drawer Front Panel

#8 1pc

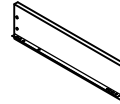

Drawer Left Side Panel

#9 1pc

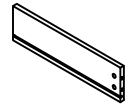

Drawer Right Side Panel

#10 1pc



Drawer Back Panel

#11 1pc

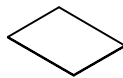

Drawer Bottom Panel

#12 1pc



Drawer Bottom Support

#13 1pc



Front Left Leg

#14 1pc



Front Right Leg

#15 1pc



Rear Left Leg

#16 1pc



Rear Right Leg

END TABLE



- Please keep instructions for future reference.
- Check the quantity and irregularity of parts and hardware before you start.

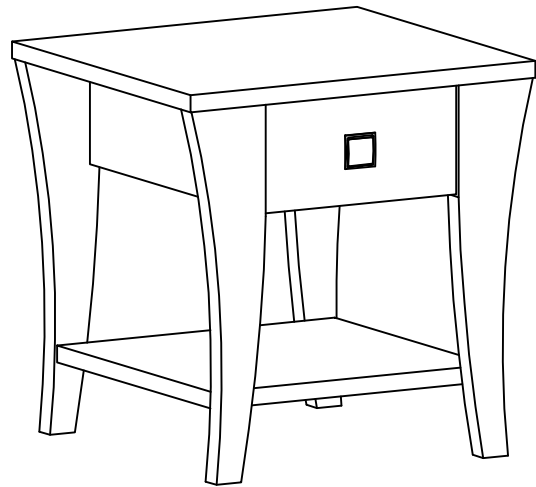

HARDWARE

#A 32pcs



Large Cam Bolt L29

#B 32pcs



Large Cam Lock Ø15

#C 12pcs



Wood Dowel Ø8x25

#D 4pcs

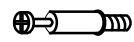

Small Cam Bolt L20

#E 4pcs



Small Cam Lock Ø12

#F 4pcs



Screw Ø4x30

#G 1pc



Handle 48x48x14

#H 1pc



Handle Screw Ø4x10

#I 4pcs



Sticker Ø22

#J 4pcs

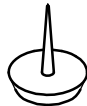

Foot Tack

#K 1pc



Glue

ASSEMBLY INSTRUCTIONS

1

Part #5 x1pc
Part #6 x1pc

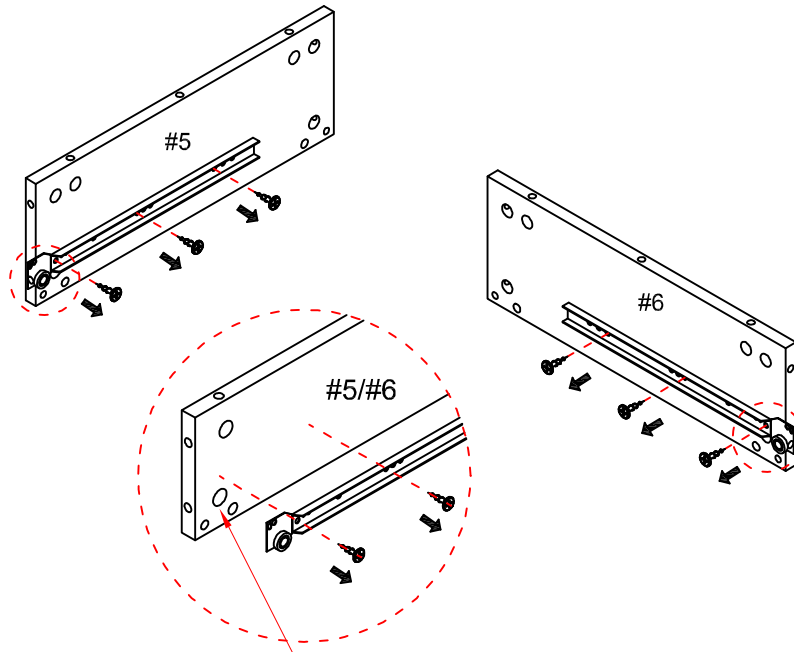

Remove slide track and open Cam Lock Hoel.

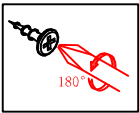

Tip: Place parts on the flat level surface to ease alignment and assemble.

2

Attach dowels (#C) and cam bolts (#A) to the holes of the left and right side panels (#5,6). Align front and rear crossbars (#3,4) to the cam bolts (#A) and dowels (#C) of left and right side panels (#5,6). Secure by using cam locks (#B).

Part #3 x1pc
Part #4 x1pc
Hardware #A x4pcs
Hardware #B x4pcs
Hardware #C x4pcs

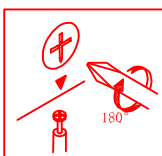
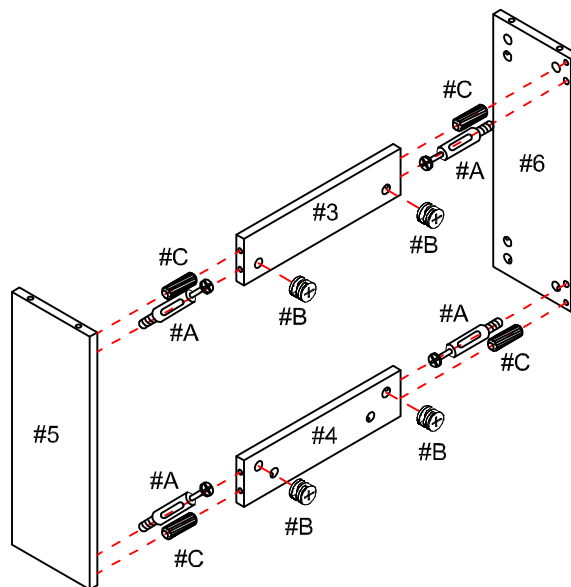

ASSEMBLY INSTRUCTIONS

3

Attach cam bolts (#A) to the holes of the rear left and right legs (#15,16). Align drawer bottom support (#12) to the cam bolts (#A) of rear left and right legs (#15,16). Secure by using cam locks (#B).

- Part #12 x1pc
- Part #15 x1pc
- Part #16 x1pc
- Hardware #A x4pcs
- Hardware #B x4pcs

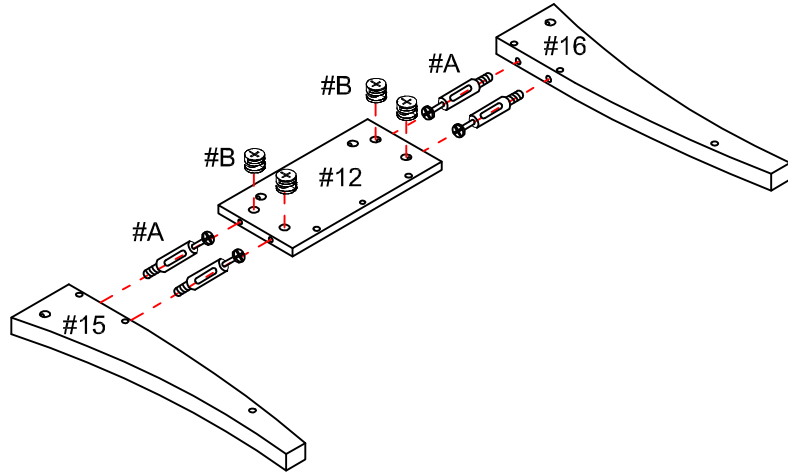

4

- Hardware #A x6pcs
- Hardware #B x6pcs
- Hardware #C x1pc

Attach cam bolts (#A) and dowels (#C) to the holes of the legs (#15,16) and bottom support (#12). Align side panels (#5,6) and crossbar (#4) to the cam bolts (#A) and dowels (#C). Secure by using cam locks (#B).

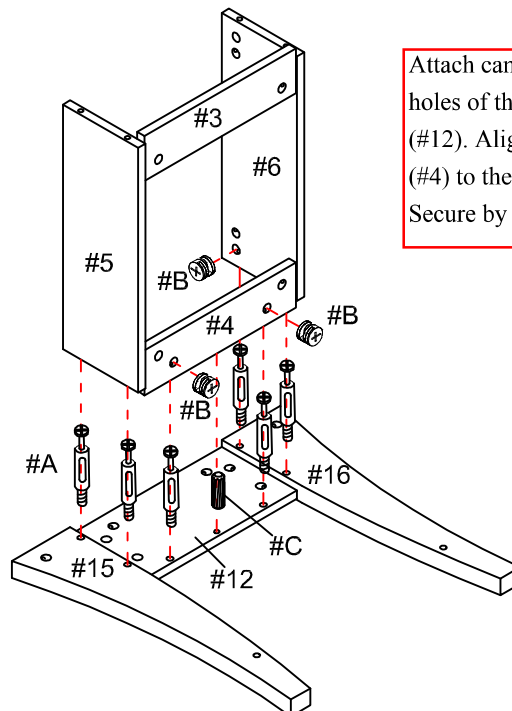
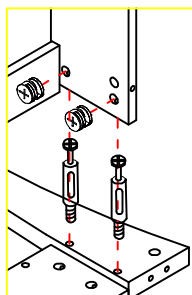

ASSEMBLY INSTRUCTIONS

5

Attach cam bolts (#A) to the holes of the legs (#15,16). Align bottom panel (#2) to the cam bolts (#A) of the legs (#15,16). Secure by using cam locks (#B).

- Part #2 x1pc
- Hardware #A x2pcs
- Hardware #B x2pcs

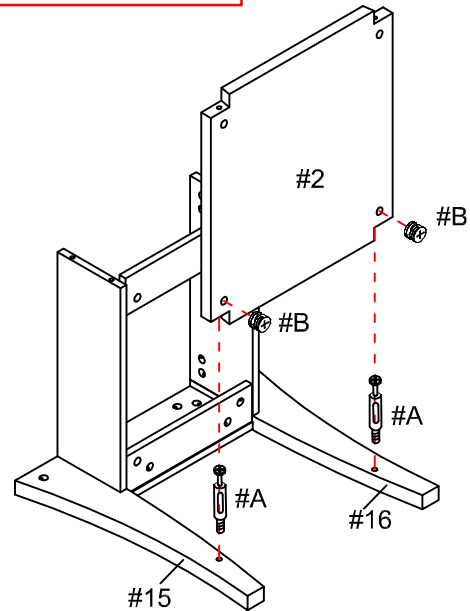

6

Attach cam bolts (#A) to the holes of the legs (#13,14). Align legs (#13,14) to the holes of the product. Secure by using cam locks (#B).

- Part #13 x1pc
- Part #14 x1pc
- Hardware #A x6pcs
- Hardware #B x6pcs

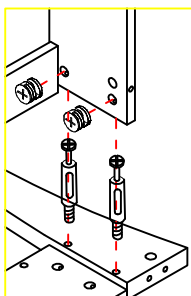
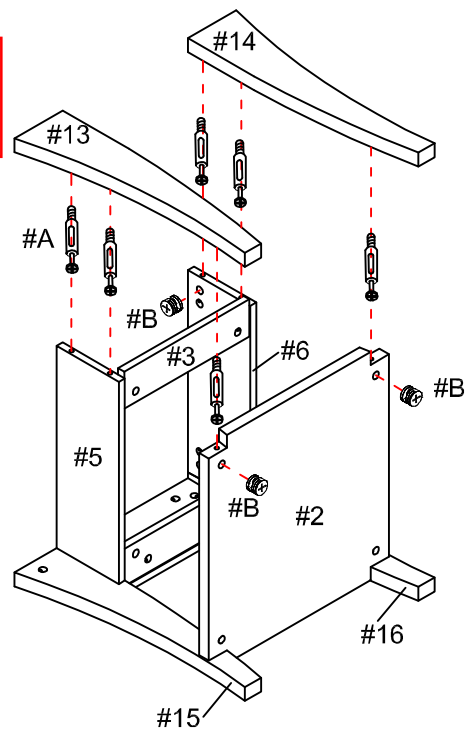

ASSEMBLY INSTRUCTIONS

7

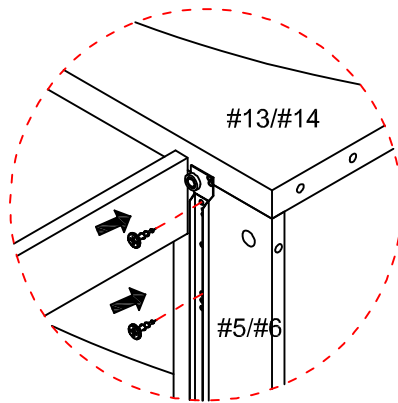

Reattach drawer rails to side panels (#5,6).

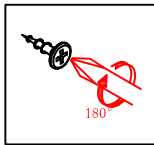
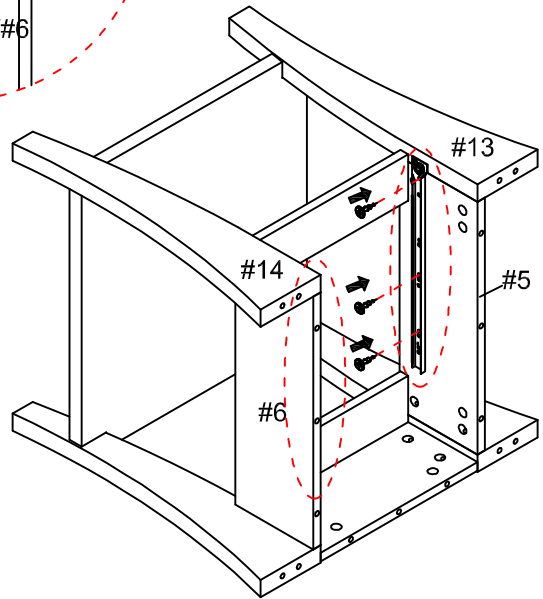

8

Part #1 x1pc

Hardware #A x10pcs

Attach cam bolts (#A) to the holes of the top panel (#1).

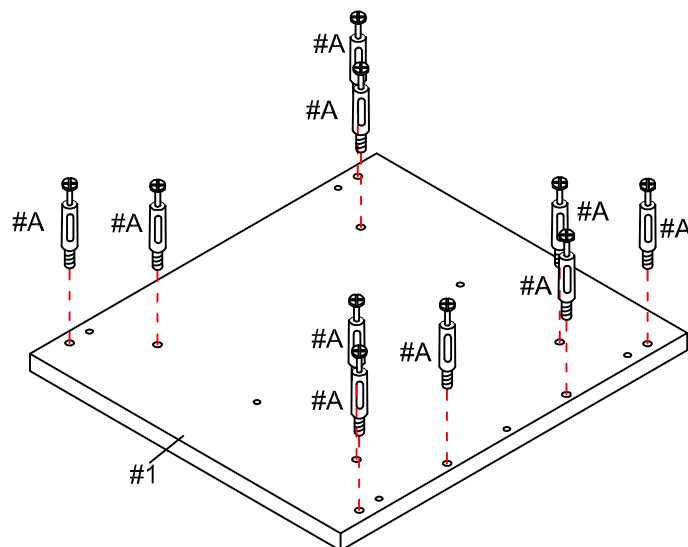

ASSEMBLY INSTRUCTIONS

9

Hardware (#B) x 10pcs

Hardware (#C) x 7pcs

Hardware (#I) x 4pcs

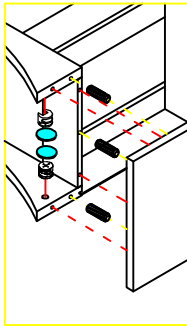

Attach dowels (#C) to the holes of the top panel (#1), then align top panel (#1) to the holes of the base. Secure by using cam locks (#B), then cover cam locks (#B) by using stickers (#I).

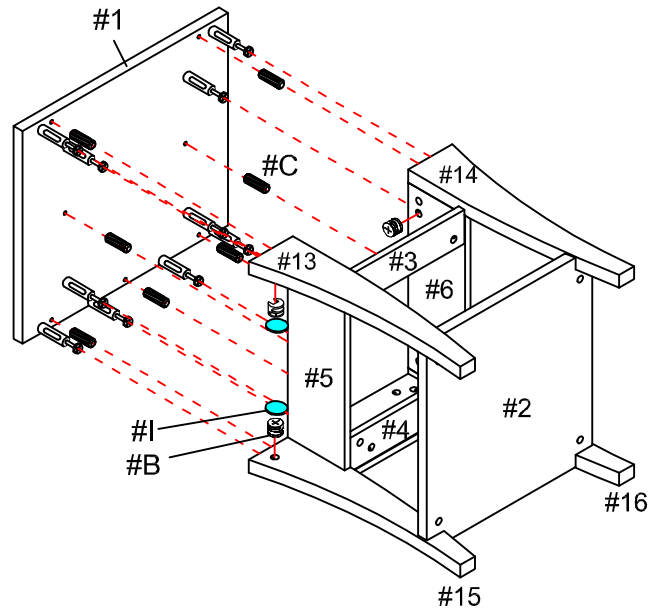

10

Hardware (#J) x 4pcs

Slightly hammer in the floor protectors (#J).

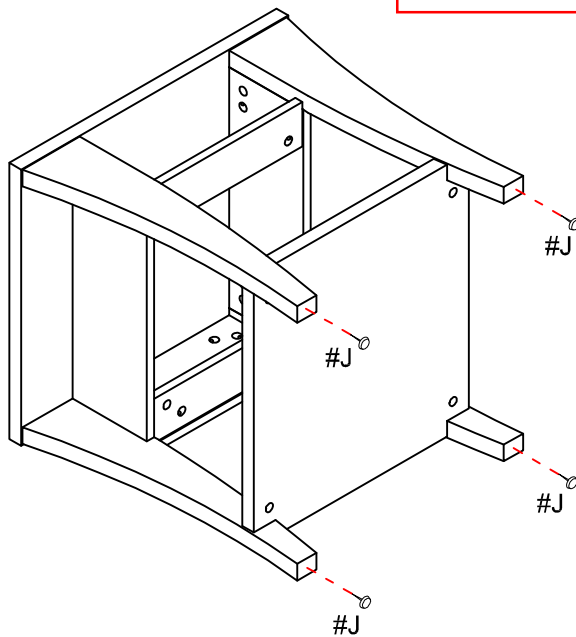

ASSEMBLY INSTRUCTIONS

11

Align handles to the front drawer panel (#7), then secure by using bolts and washers (#H).

- Part #7 x 1pc
- Hardware #G x 1pc
- Hardware #H x 1pc

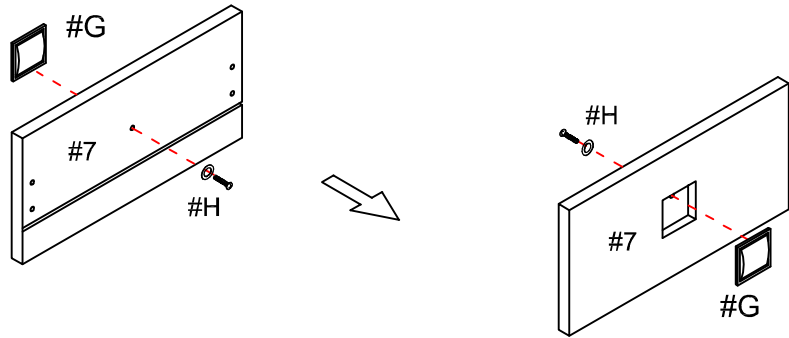

12

Align side drawer panels (#8,9) to the holes of the back drawer panel (#10), then secure by using screws (#F).

#F x 4pcs

- Part #8 x 1pc
- Part #9 x 1pc
- Part #10 x 1pc
- Hardware #F x 4pcs

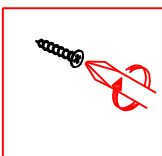
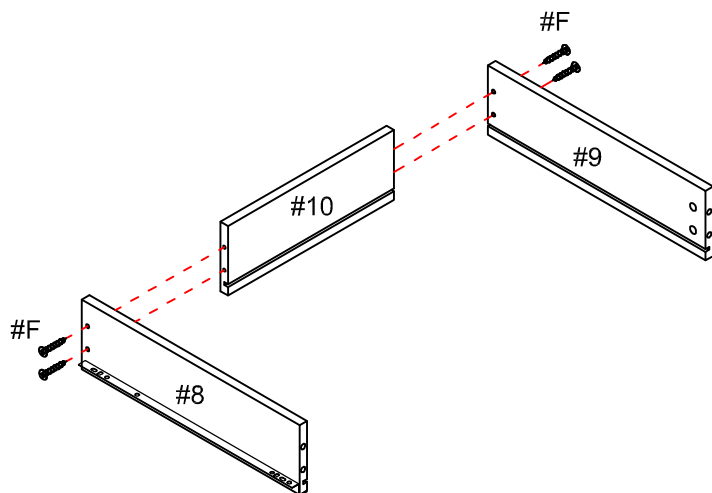

ASSEMBLY INSTRUCTIONS

Align and slide bottom panel (#11) through the thin lined gaps of the drawer panels.

13

Part  x 1pc

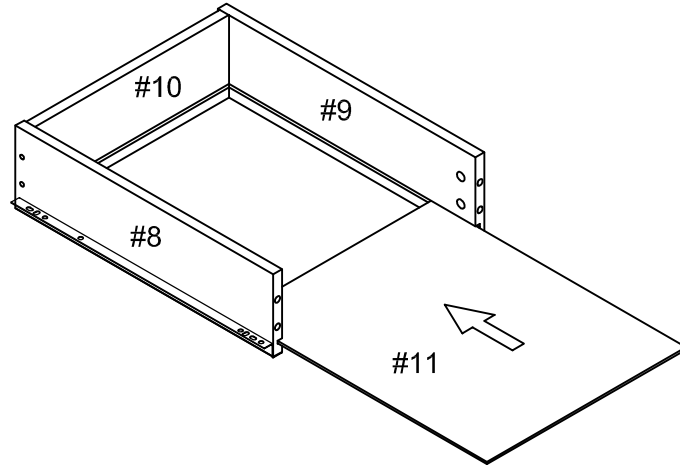

14

Attach cam bolts (#D) to the holes of the front drawer panels (#7). Align front drawer panel (#7) to the holes of the drawer. Secure by using cam bolts (#E).

Hardware  x 4pcs

Hardware  x 4pcs

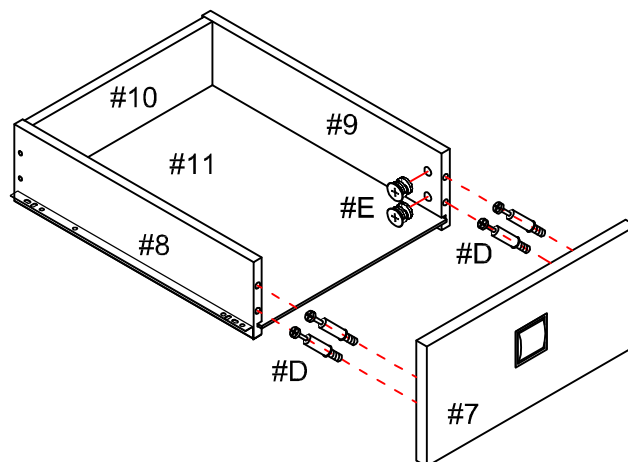

ASSEMBLY INSTRUCTIONS

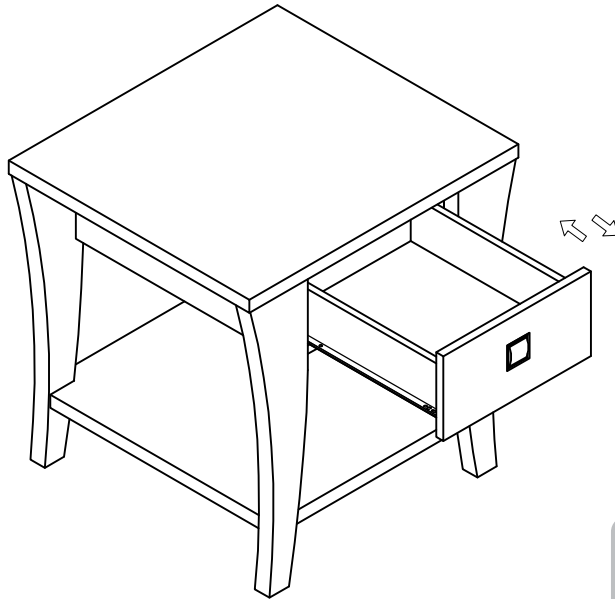

ASSEMBLY COMPLETED



Please ensure the furniture rests on an even and flat surface. If the product wobbles or feels loose, double-check all bolts and/or screws are properly tightened and secured.



Keep this handy!

Please retain this instruction manual and any order-related information for future reference.