

INSTALLATION

Product Manual

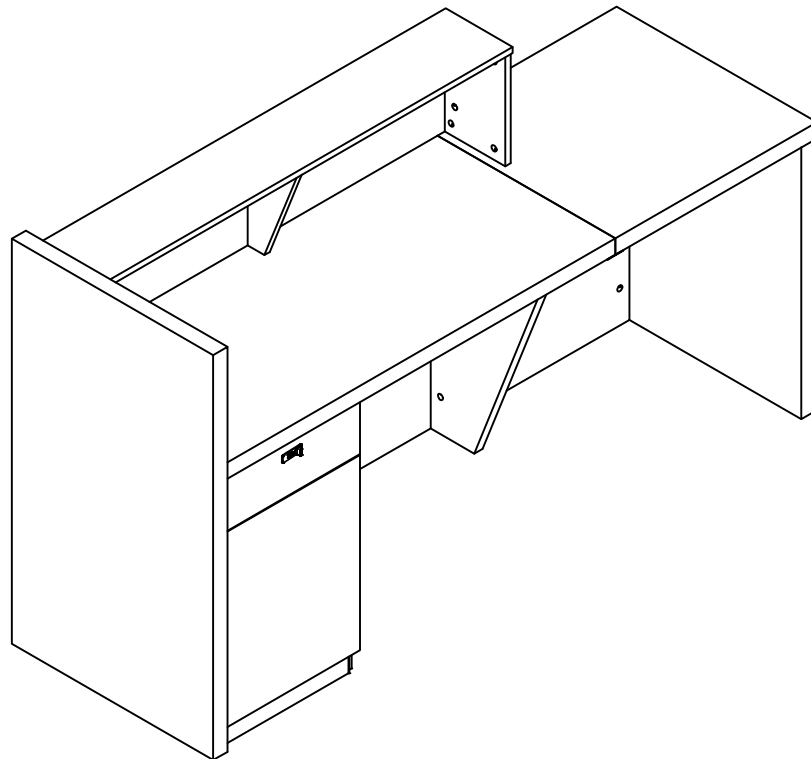

Product name: 71 IN RECEPTION DESK







Version:27RJS065-006

Product Size: 70.9 X 23.6 X 41.3 INCH





Universal Reception Desk – Installation & Safety Notes

Thank you for choosing our furniture. Please read this manual carefully to ensure safe and correct assembly.





1. Before Installation

-  Read Carefully: Review all steps before starting assembly.
-  Check Parts: Confirm all panels, screws, and hardware are complete. Contact the seller if any item is missing or damaged.
-  Tools: Prepare a Phillips screwdriver, rubber mallet, and tape measure. Use low-speed electric tools if necessary.
-  Teamwork: Two people are recommended for installation.
-  Setup Area: Assemble on a flat, clean surface with padding underneath.
-  Child Safety: Keep small items and plastic bags away from children.



2. Assembly Precautions

-  Assembly Order: Pre-fit all parts before final tightening.
-  Cam Locks: Rotate ¼ turn and lock both sides securely.
-  Avoid Force: Do not hammer or over-tighten screws.
-  No Dragging: Always lift with two people, do not drag on the floor.

3. Usage & Maintenance

-  Cleaning: Wipe with a dry or slightly damp cloth. Avoid harsh chemicals or bleach.
-  Moisture: Keep in a dry, ventilated area away from water.
-  Sunlight: Avoid prolonged sunlight exposure.
-  Maintenance: Retighten screws after 2 weeks and every 3 months.
-  Load Limit: Do not stand or place heavy items on the tabletop.

4. After-Sales Support

-  Installation Questions: Contact your seller for assistance.
-  Return Policy: As this is a large item, please DO NOT return or disassemble without authorization. Contact the seller to confirm the process and address. Returns with damaged or incomplete packaging may be refused.
-  Replacement Parts: If parts are missing or damaged, take photos and contact the seller. We will provide replacements promptly or assist with logistics claims.

Mostrador de Recepción Universal – Guía de Montaje y Cuidado

Gracias por elegir nuestros muebles. Lea este manual cuidadosamente antes de comenzar la instalación.

1. Preparación



Lea antes de montar: Revise todos los pasos antes de comenzar.



Revise las piezas: Asegúrese de que todas estén completas. Si falta algo, contacte al vendedor.



Herramientas: Destornillador Phillips, martillo de goma, cinta métrica.



Dos personas: Se recomienda montaje con dos personas.



Área: Monte en una superficie plana con base protectora.



Seguridad infantil: Mantenga piezas pequeñas lejos de los niños.

2. Instrucciones de montaje



Orden: Ensamble todas las piezas y apriete al final.



Bloqueo de leva: Gire ¼ de vuelta para asegurar.



No fuerce: No golpee ni apriete demasiado.



No arrastre: Levante entre dos personas, no arrastre.

3. Uso y mantenimiento



Limpieza: Limpie con un paño seco o húmedo. Evite productos fuertes.



Humedad: Mantenga en un lugar seco y ventilado.



Sol: Evite exposición solar directa.



Mantenimiento: Revise y apriete tornillos cada 3 meses.



Peso: No se siente ni coloque objetos pesados.

4. Servicio posventa



Dudas: Contacte al vendedor si necesita ayuda.



Devolución: Este es un producto voluminoso. NO lo devuelva sin autorización.

Contacte al vendedor para confirmar el proceso y dirección.





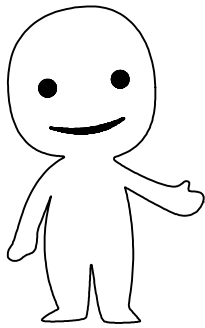



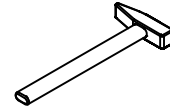
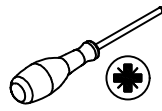
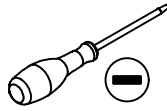











Repuestos: En caso de piezas faltantes o dañadas, envíe fotos al vendedor para recibir reemplazo gratuito.



Please prepare the following tools

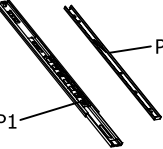

When installing, please carefully confirm whether each screw corresponds to the manual, accessories with similar shapes can be distinguished by size

A x 41  15A	B x 41  15A	C x 41  15A	D x 22  Ø8 x 30 mm	E x 4 
F x 15  M4x 14 mm	G x 8  M4 x 16 mm	H x 2  M6 x 20mm	I x 2 	J x (16+16) 
K x 4  12A	L x 4  12A	M x 1 	N x 4  M3 x 30 mm	O x 4  M5 x10mm
P x 1sets 	Q x 1  130x48x1.5 mm	R x 1 	S x 1 	

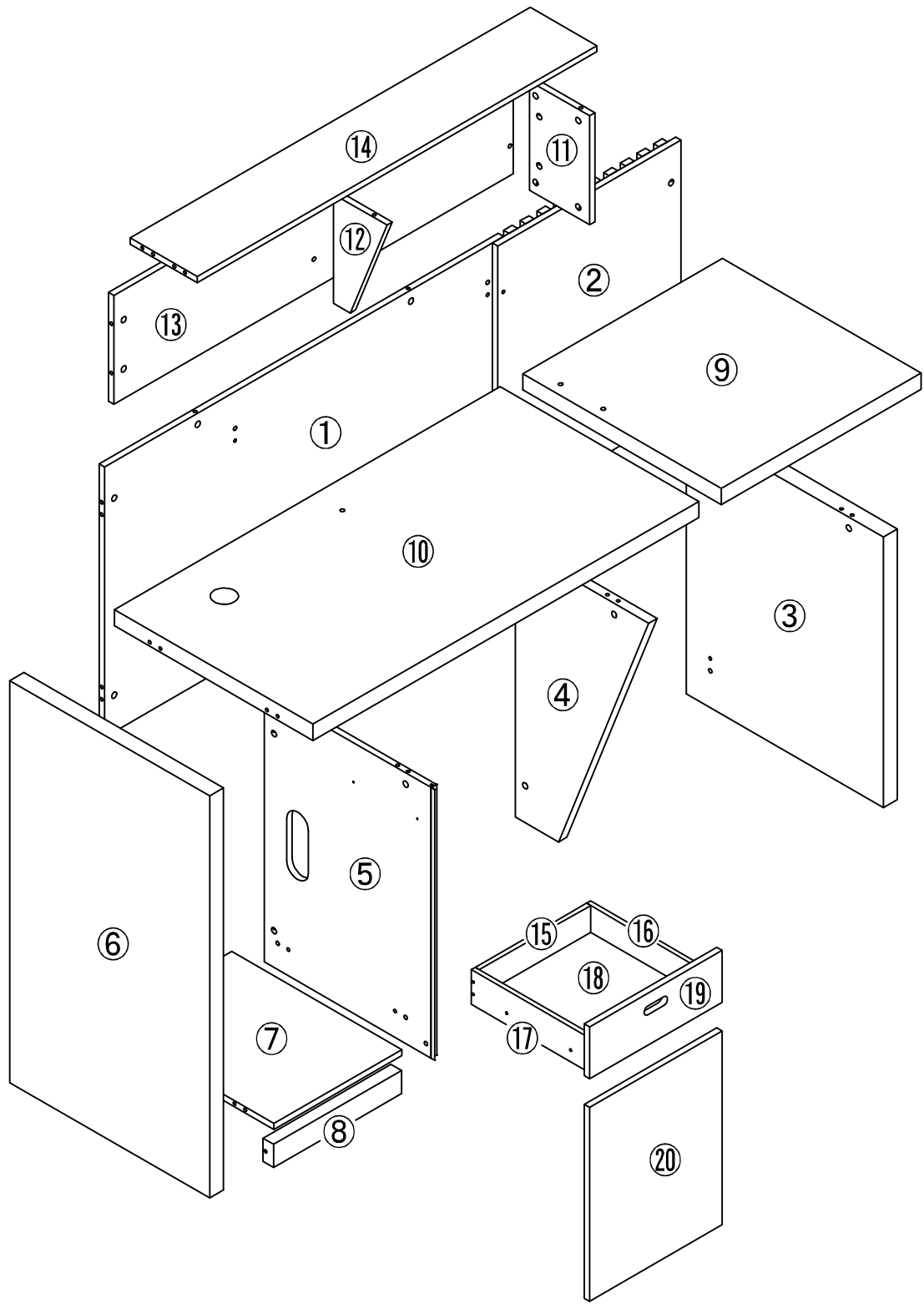

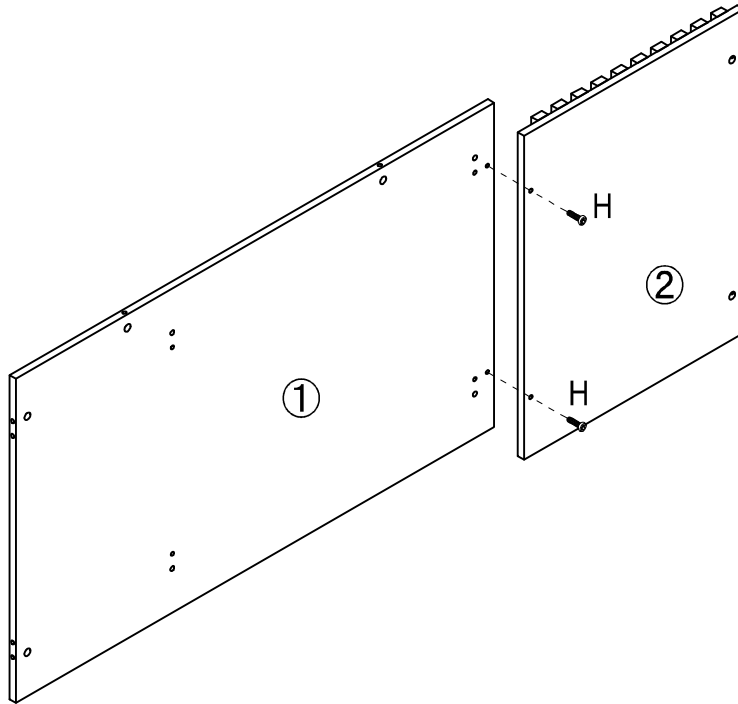
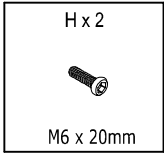

Step 1

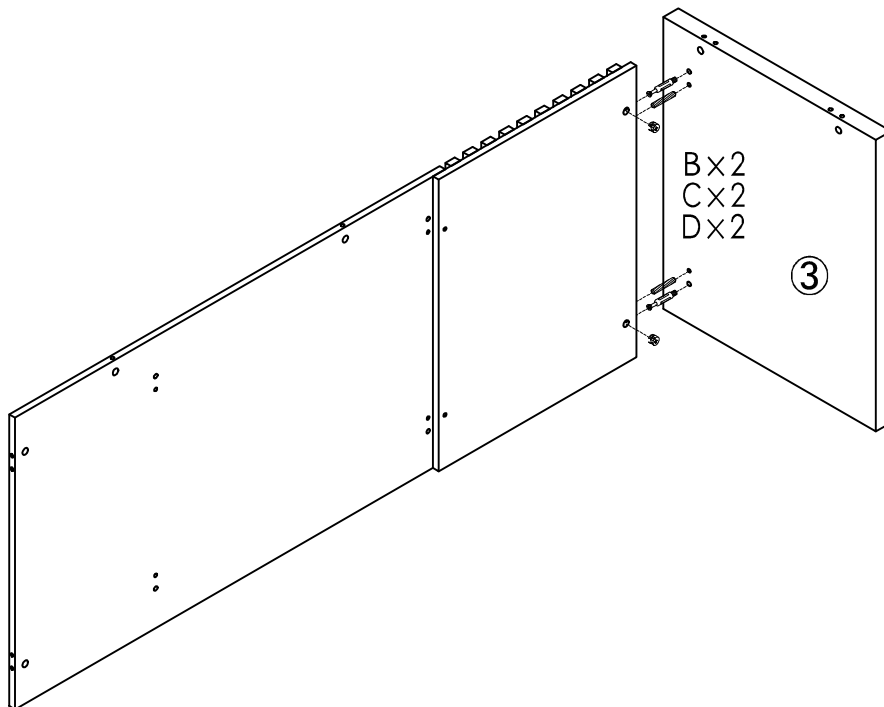
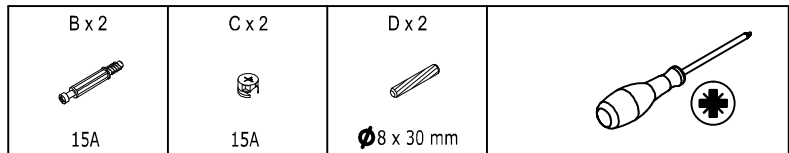

Step 2



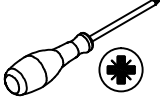

Step 3

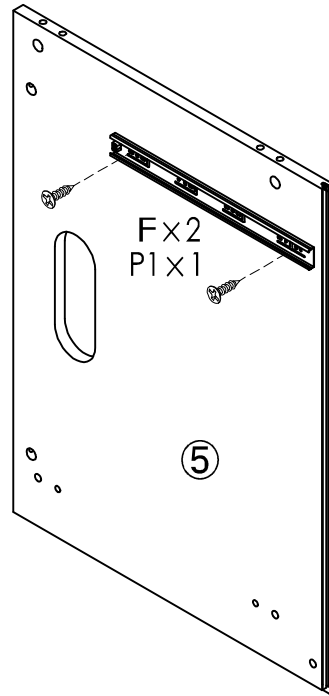
F x 2  M4x 14 mm	P1 x 1 	
---	---	---



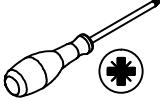

Step 4

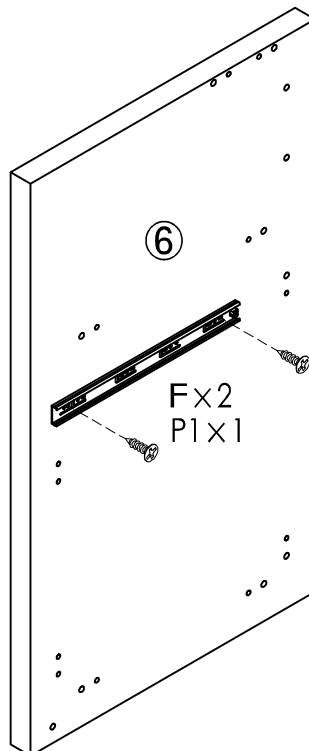
F x 2  M4x 14 mm	P1 x 1 	
---	---	---



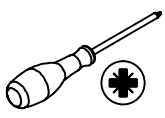

Step 5

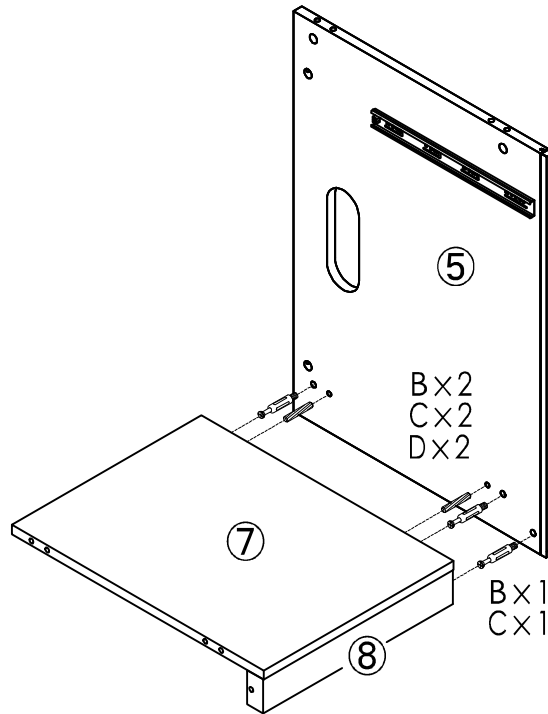
B x 3  15A	C x 3  15A	D x 2  ∅8 x 30 mm	
---	---	--	--





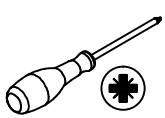

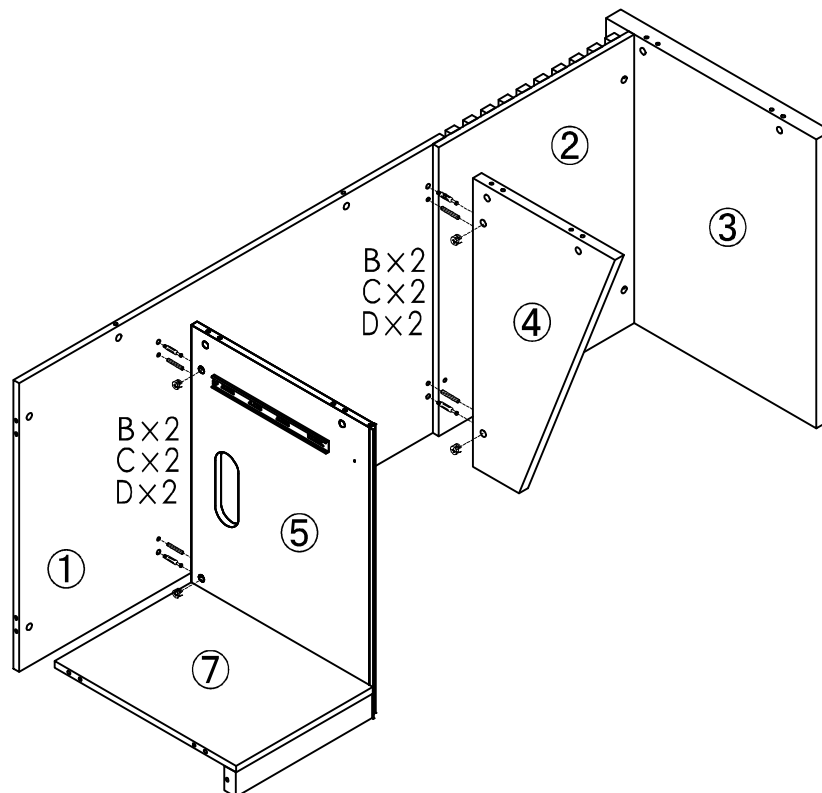
Step 6

B x 4  15A	C x 4  15A	D x 4  ∅8 x 30 mm	
---	---	--	---



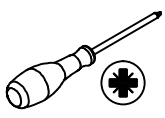

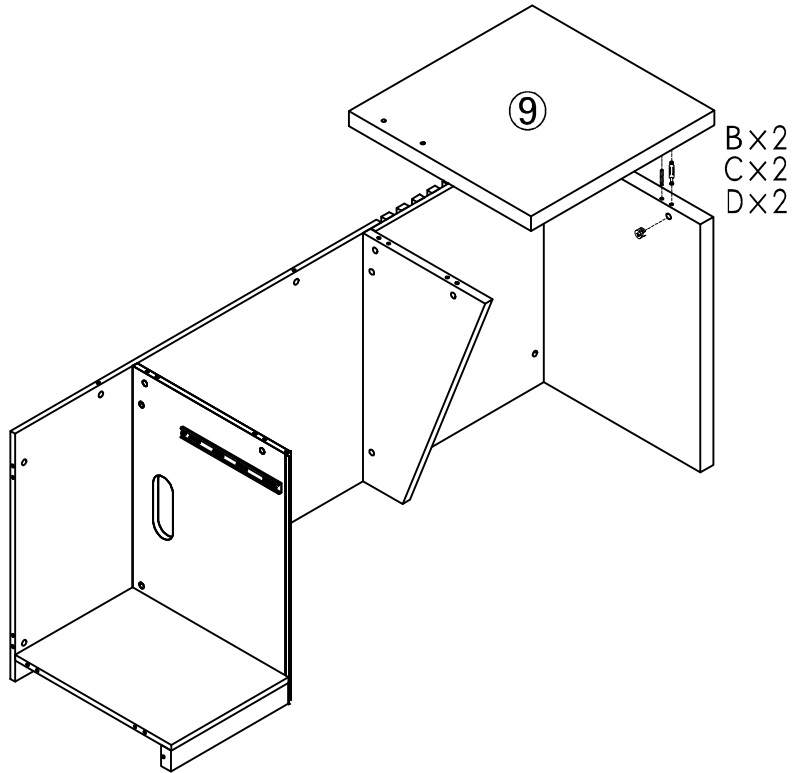

Step 7

B x 2  15A	C x 2  15A	D x 2  Ø8 x 30 mm	 
---	---	--	---



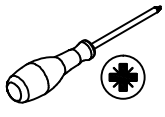

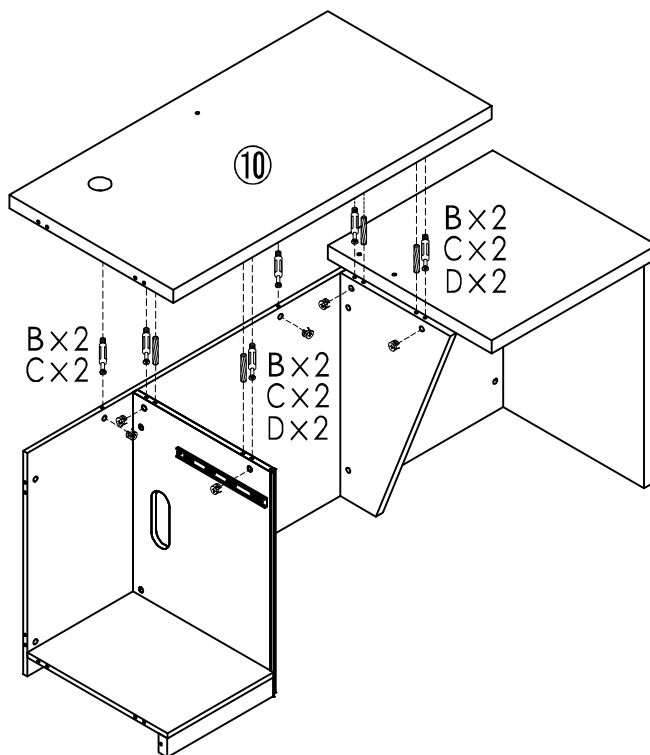

Step 8

B x 6  15A	C x 6  15A	D x 4  Ø8 x 30 mm	 
---	---	--	--



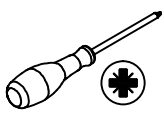

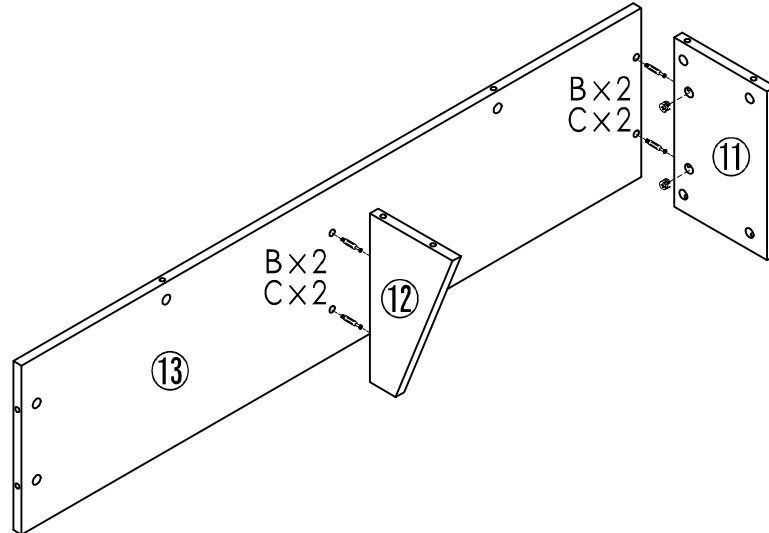

Step 9

B x 4  15A	C x 4  15A	 
---	---	---

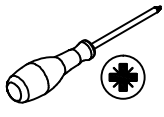

Step 10

B x 6  15A	C x 6  15A	 
---	---	--

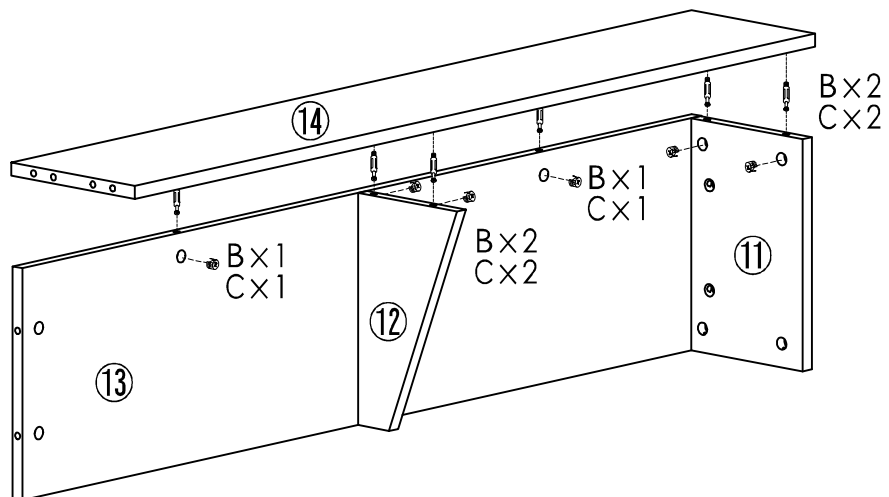

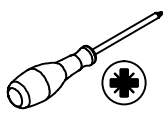

Step 11

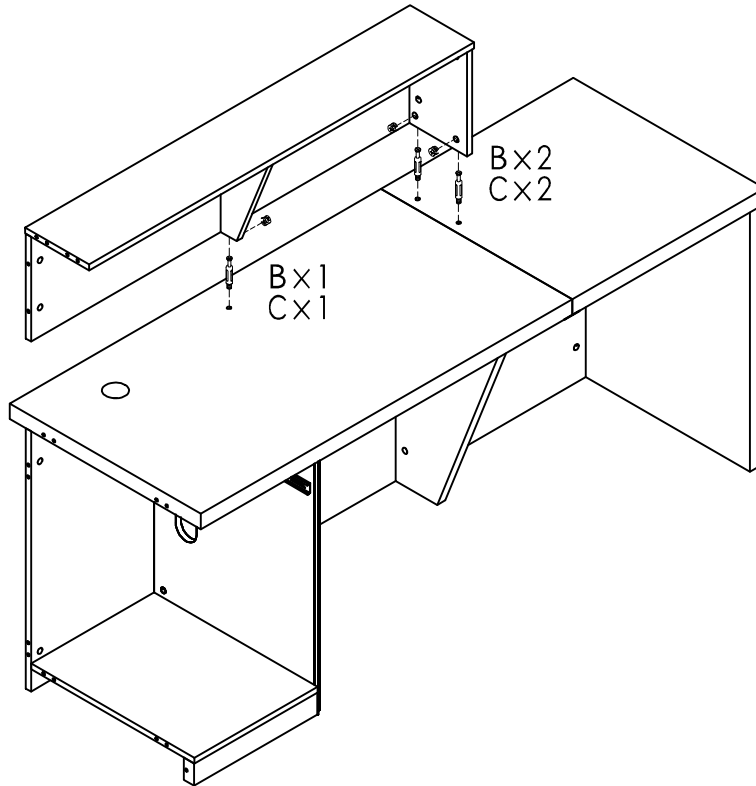
B x 3  15A	C x 3  15A	
---	---	--





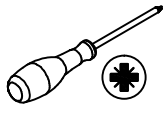

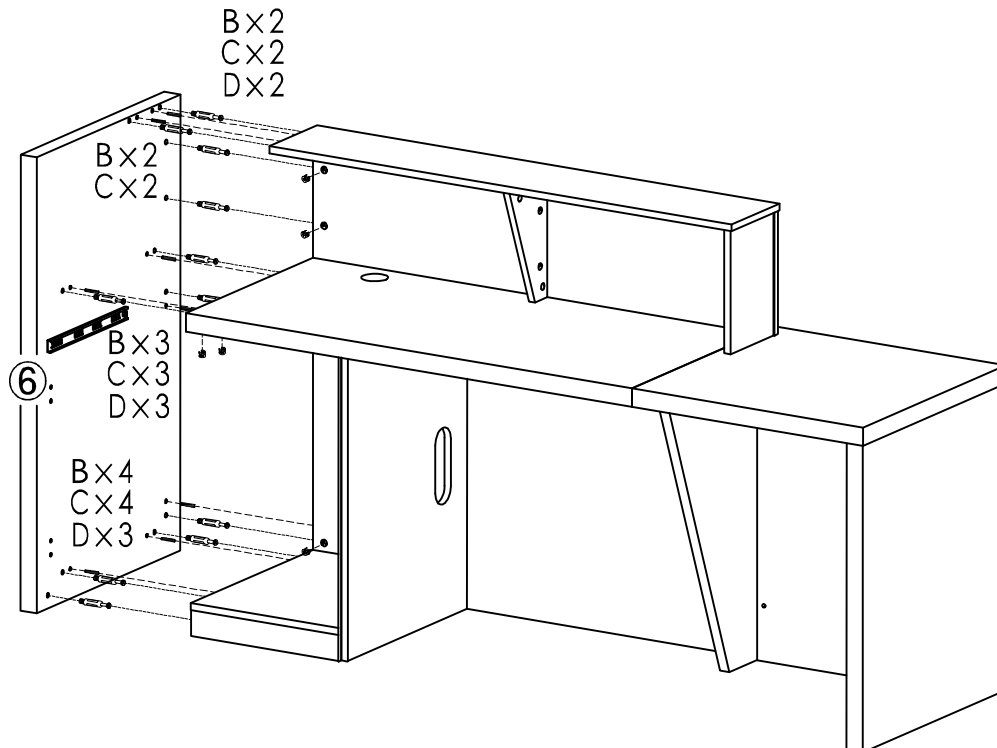

Step 12

B x 11  15A	C x 11  15A	D x 8  ∅8 x 30 mm	
--	--	--	---



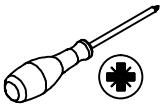

Step 13

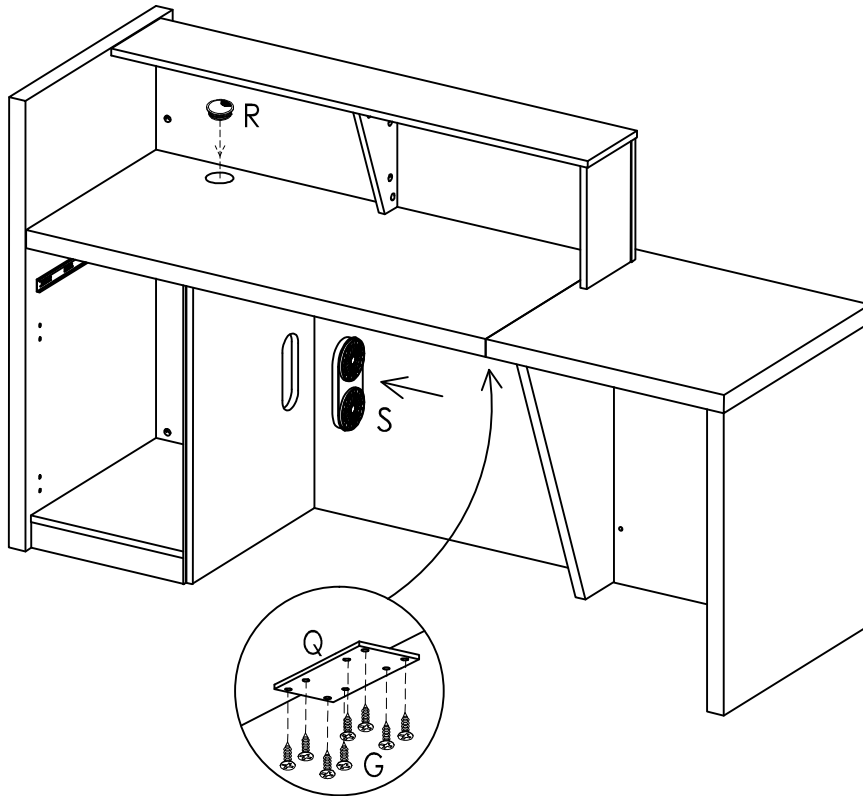
G x 8  M4x 16 mm	Q x 1  130x48x1,5 mm	R x 1 	S x 1 	 
---	---	---	--	--

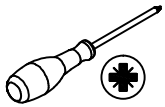

Step 14

N x 4  M3 x 30 mm	 
--	--

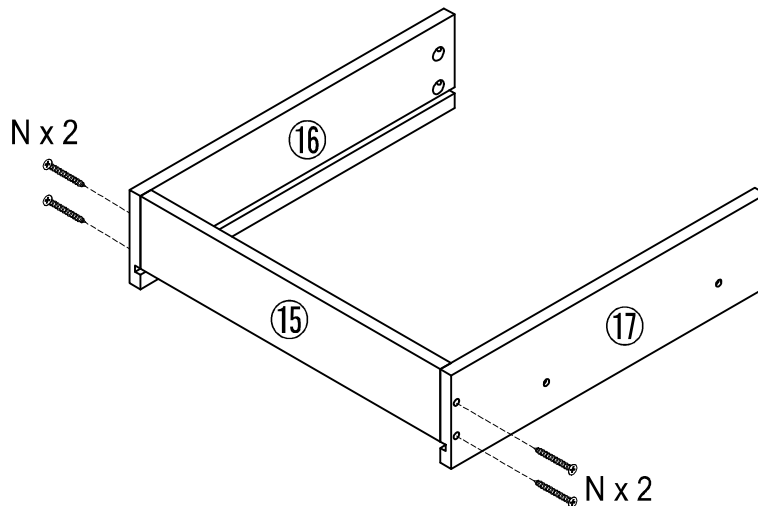

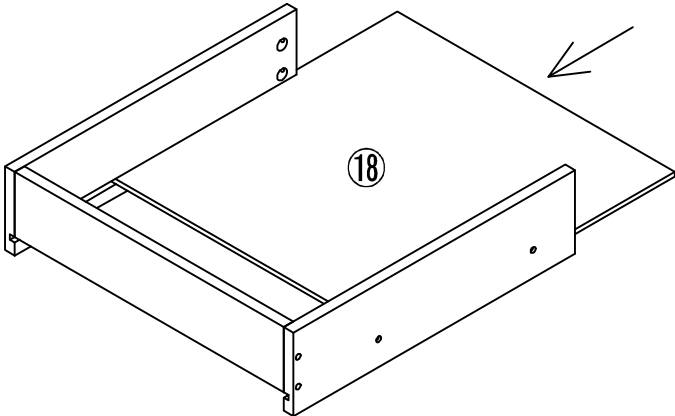

Step 15

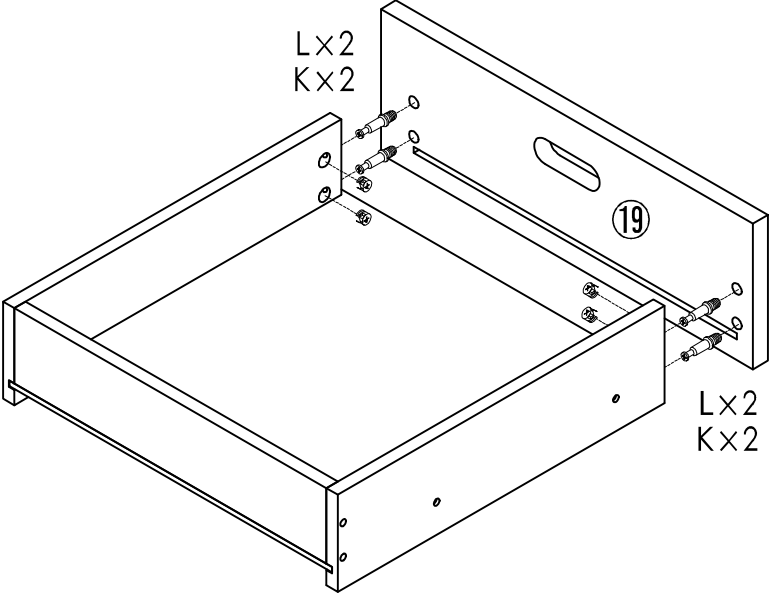

Step 16



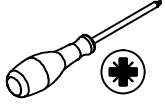

Step 17

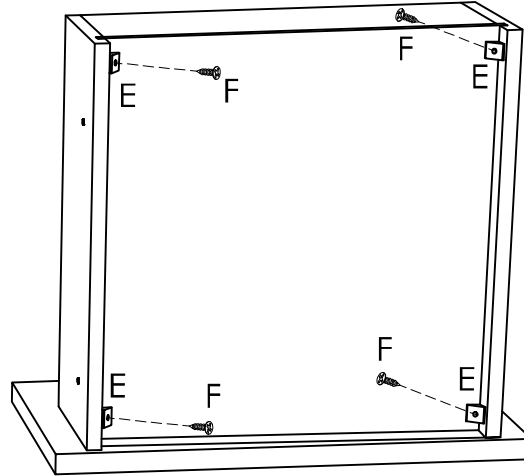
E x 4 	F x 4  M4x 14 mm	
--	---	---

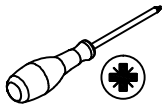

Step 18

F x 4  M4x 14 mm	P2 x 2 	
---	---	---

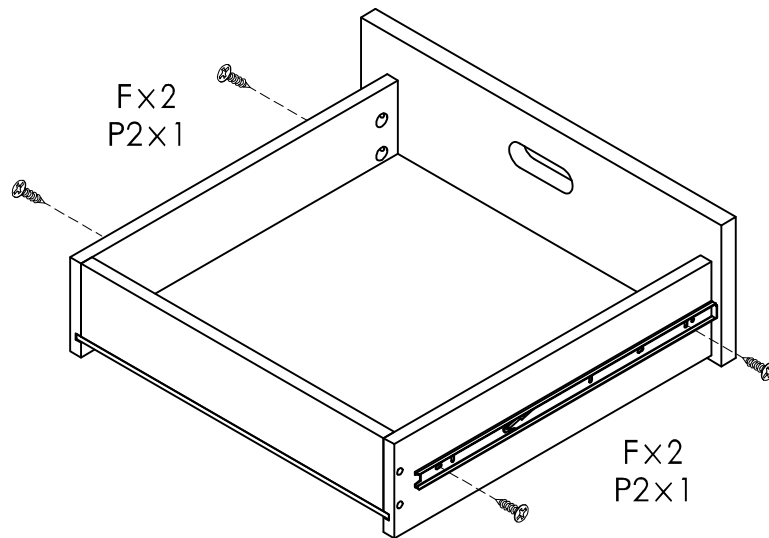

Step 19



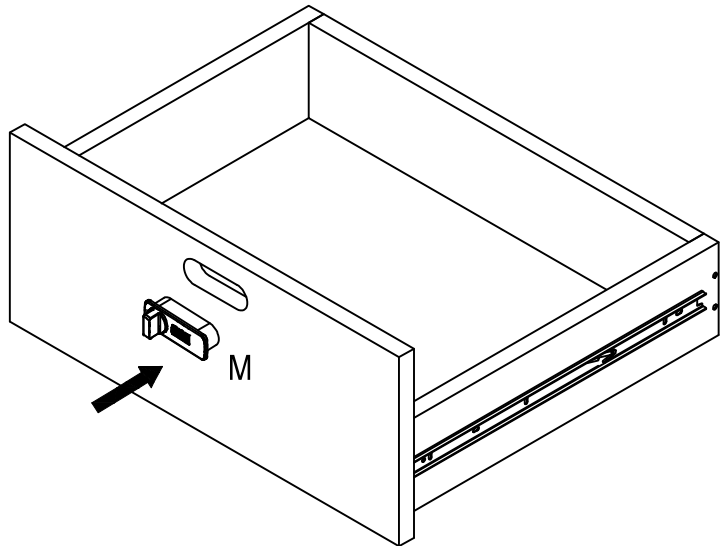

<p>M x 1</p> 	
--	---

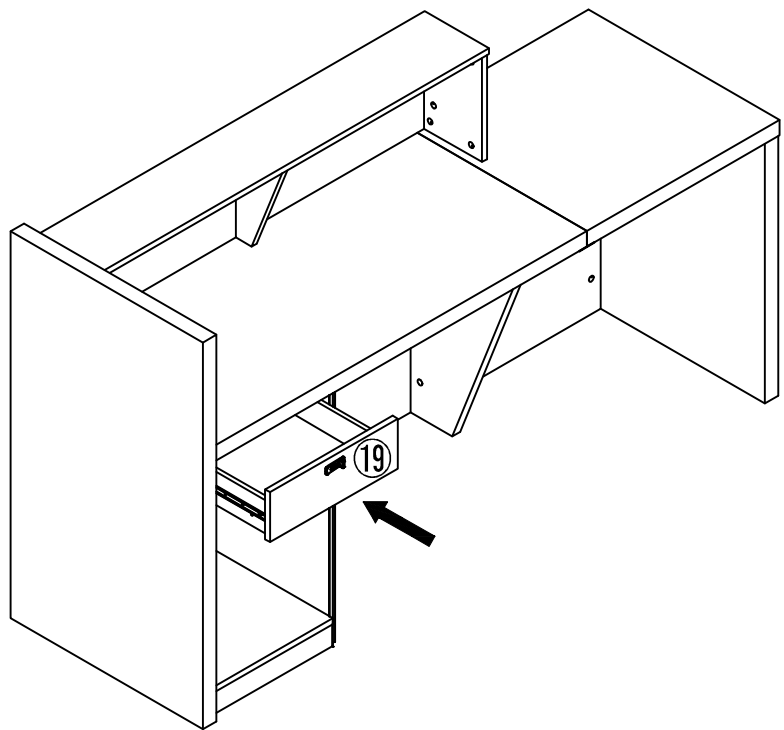

Step 20

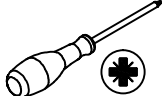

Step 21

F x 12  M4x 16 mm	I x 2 	 
--	--	--

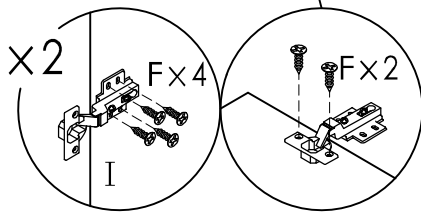
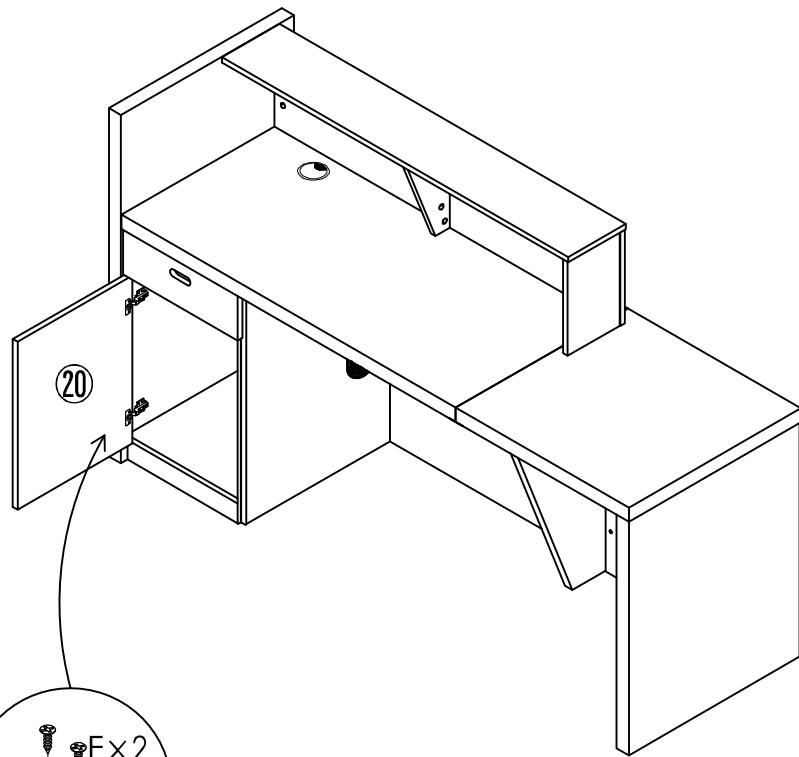

Thank You for Purchasing Our Product

Dear Customer,

Thank you for choosing our product! We sincerely appreciate your trust and support. Our mission is to craft furniture that blends functionality, durability, and elegant design to enrich your space. We hope this product brings comfort and inspiration to your workplace. Should you need any assistance or wish to share feedback, please contact us anytime – our team is here to help.

Sincerely,

Customer Support Team

Estimado cliente,

¡Gracias por elegir nuestro producto! Agradecemos sinceramente su confianza y apoyo. Nos comprometemos a crear muebles que combinen funcionalidad, durabilidad y un diseño elegante. Esperamos que este producto aporte comodidad y estilo a su espacio de trabajo. Si necesita ayuda o desea compartir sus comentarios, no dude en contactarnos.

Atentamente,

Equipo de atención al cliente

お客様へ

この度は弊社製品をお買い上げいただき、誠にありがとうございます。私たちは、機能性・耐久性・デザイン性を兼ね備えた家具づくりを通じて、お客様の空間に快適さと美しさをお届けすることを目指しています。この製品が皆様のオフィスや生活空間でお役に立てれば幸いです。ご不明点やご意見がございましたら、いつでもお気軽にお問い合わせください。

カスタマーサポートチーム

PLEASE DO NOT RETURN TO STORE



**Please do not return this product to the retailer!
We are here to assist you directly in ANY way!
If you encounter any issue with assembly, or if any part is missing or damaged, please contact our customer service team before taking further action.**

**¡NO DEVUELVA ESTE PRODUCTO A LA TIENDA!
¡Estamos aquí para ayudarle directamente en todo lo que necesite!
Si encuentra algún problema durante el montaje, o si falta o está dañado algún componente,
póngase en contacto con nuestro servicio de atención al cliente antes de tomar cualquier otra medida.**

この製品を販売店に返品しないでください!
組立の際に問題が発生した場合、または部品の不足・破損があった場合は、
まずは弊社カスタマーサービスまでご連絡ください。
お客様を直接サポートいたします!