

---

**CHROME QUILTED BARSTOOL**  
**TABOURET DE BAR CHROMÉ ET MATELASSÉ**  
**TABURETE DE BAR CROMADO Y ACOLCHADO**

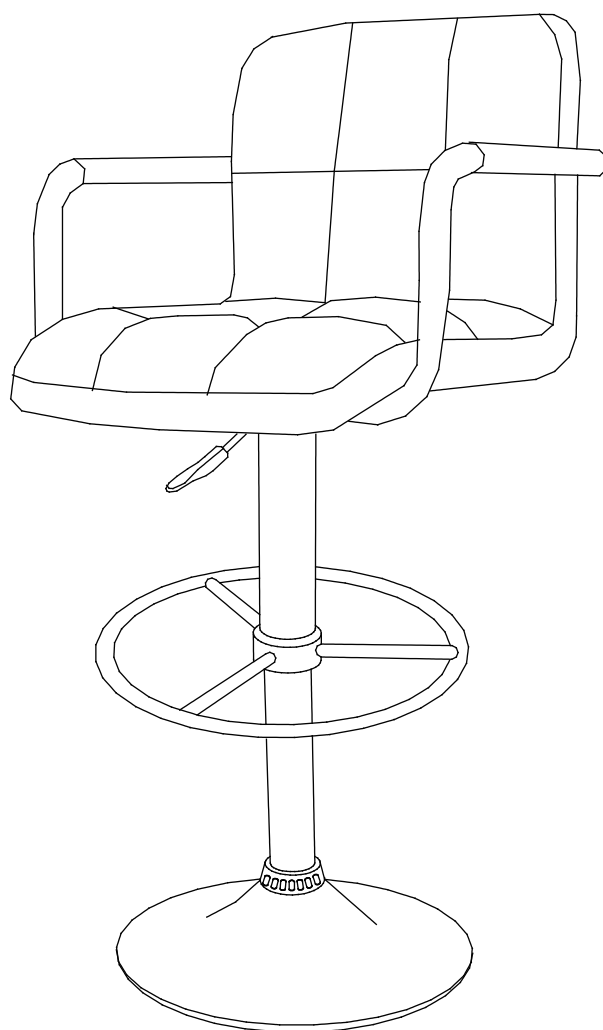

## PART LIST

#1	SEAT	01
#2	UPPER POST	01
#3	ARM	01
#4	NUMMULAR	01
#5	LOWER POST	01
#6	THIMBLE	01
#6	BASE	01

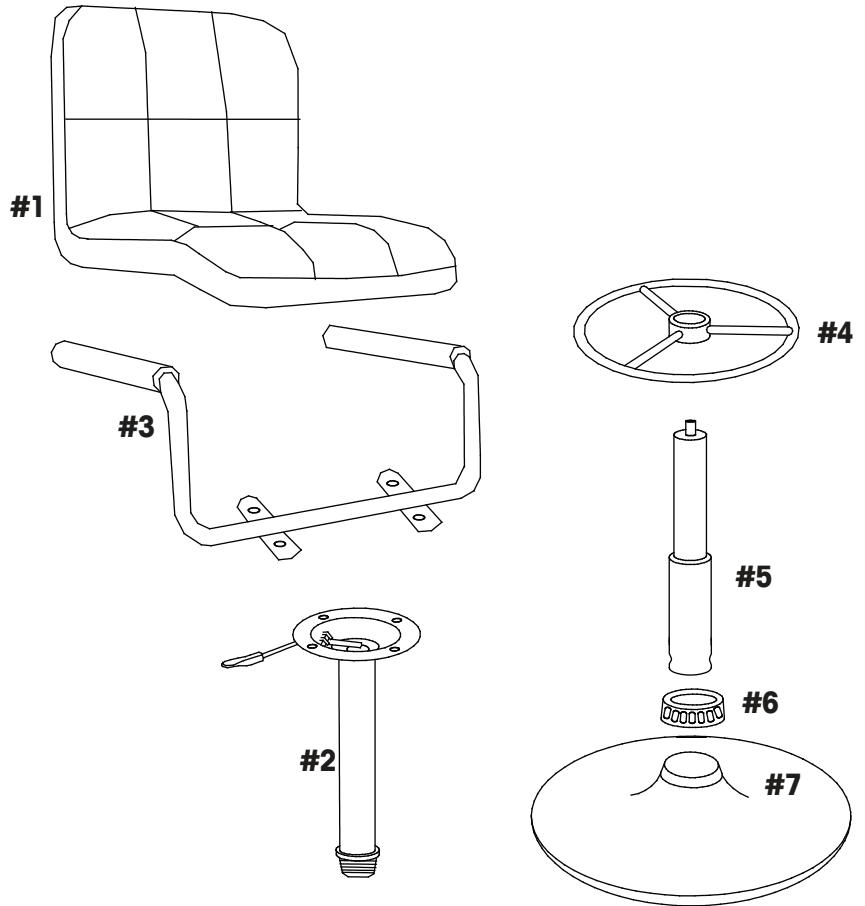

## HARDWARE LIST

A	BOLT (Ø1/4"x1")		02
B	BOLT (Ø1/4"x11/16")		06
C	FLAT WASHER		08

## TOOLS REQUIRED

ALLEN KEY		SUPPLIED
-----------	--	----------

## IMPORTANT:

1. Do not tighten bolts completely until all bolts are completely lined up and inserted into holes / nuts.
2. Do not over tighten screws and bolts to avoid stripping.
3. Please use hand tools to assemble this product. Do not use power tools.

**1.**

**Remove and discard plastic cap cover.**

**All Parts MUST be assembled as shown and only with tools provided. Do not assemble any other way.**

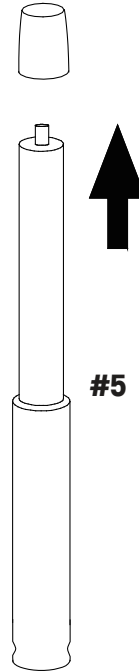

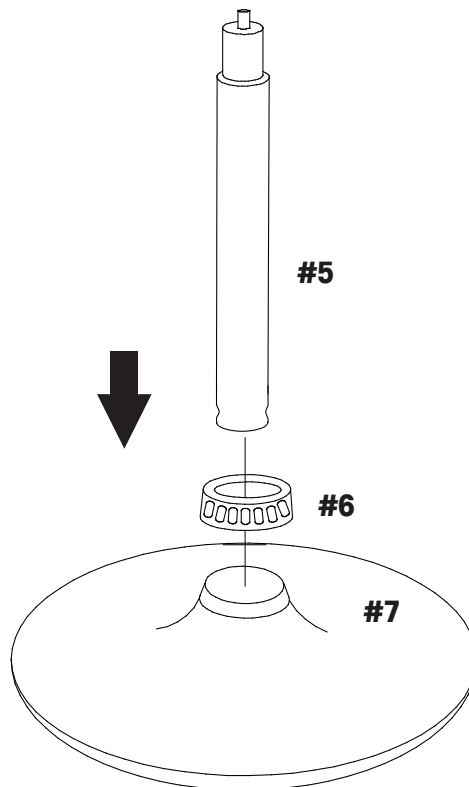

**2.**



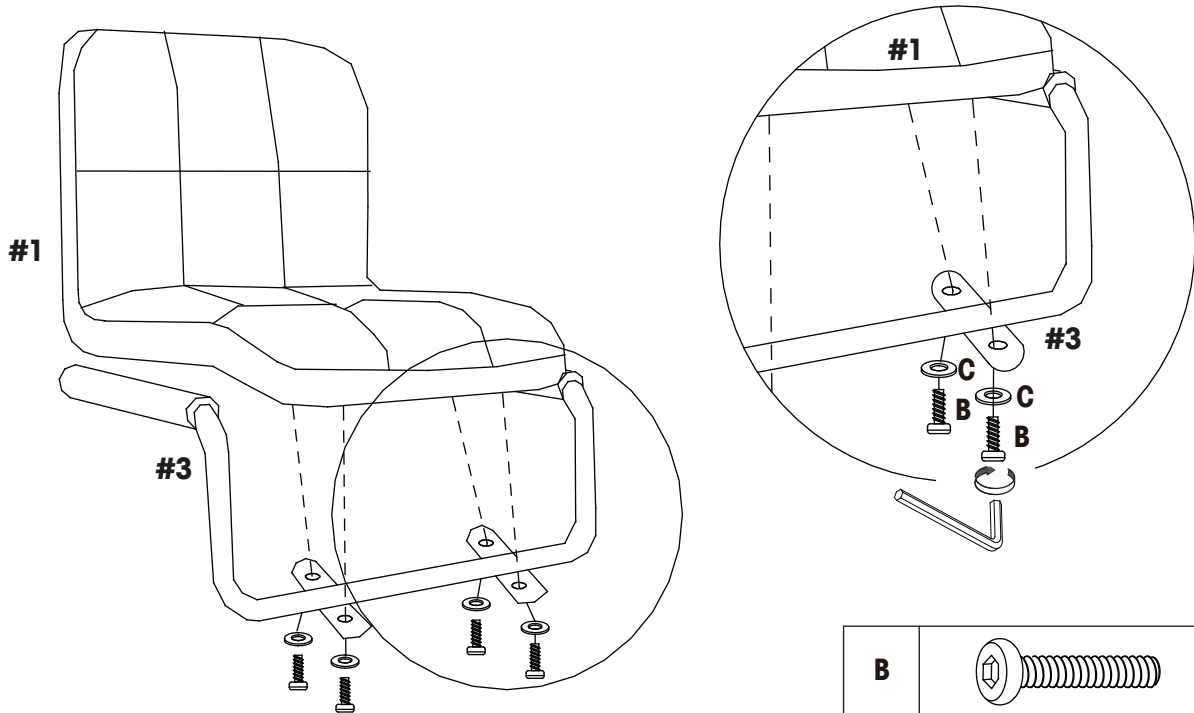

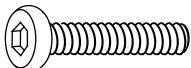
3.

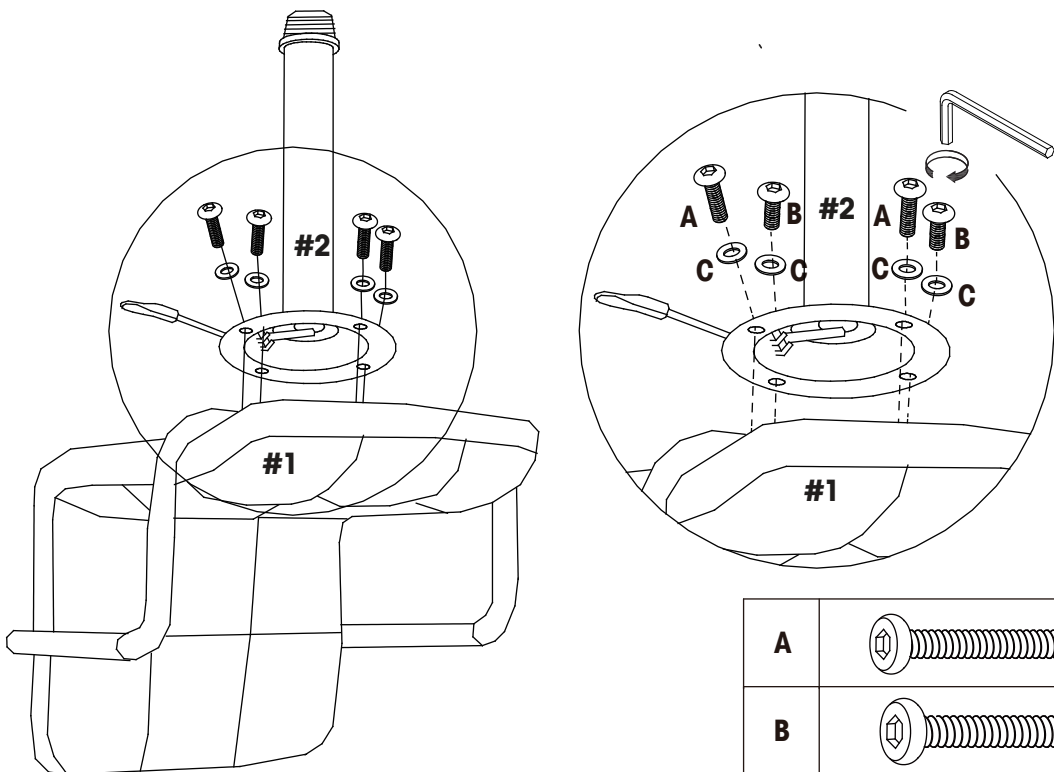

B		04
C		04

4.

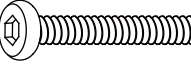

A		02
B		02
C		04

5.

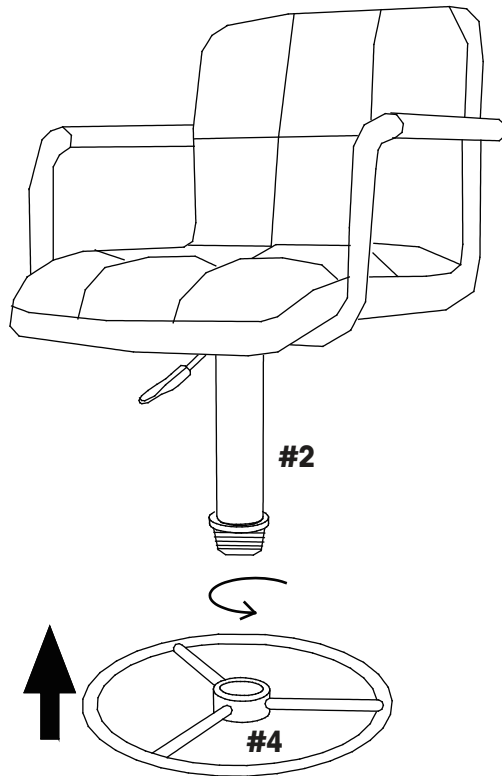

6.

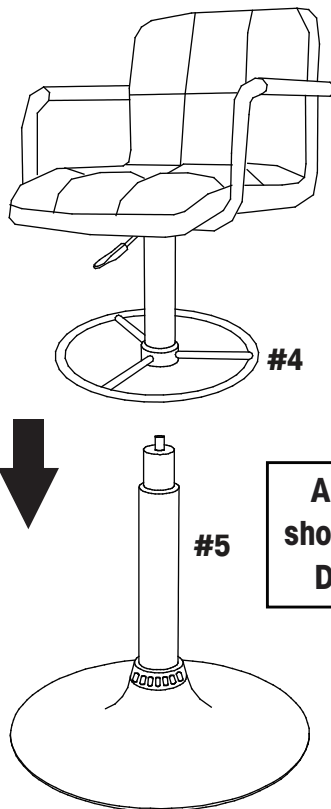

**All Parts MUST be assembled as shown and only with tools provided. Do not assemble any other way.**

7.

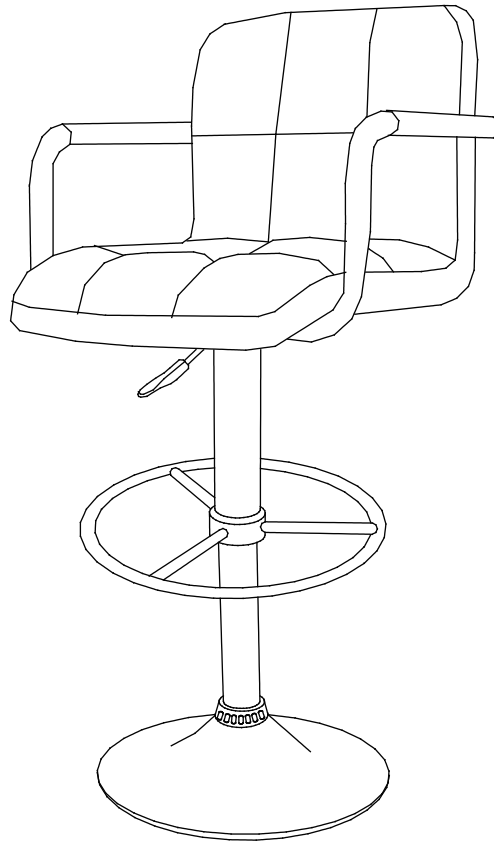
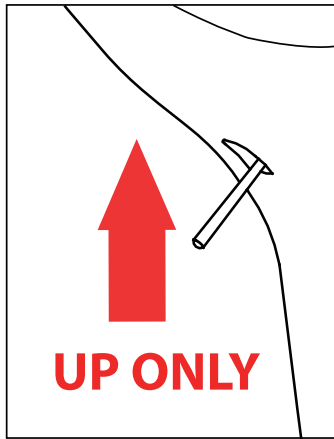

8.

**Maximum Weight 275 lbs**  
**Poids maximum: 275 lb (124.7 kg)**  
**Peso máximo: 275 lb (124.7 kg)**

